 Read this manual carefully before operating this vehicle.

OWNER'S MANUAL



XF50E

15P-F8199-E2

 **Read this manual carefully before operating this vehicle. This manual should stay with this vehicle if it is sold.**

Welcome to the Yamaha world of motorcycling!

As the owner of the XF50E, you are benefiting from Yamaha's vast experience and newest technology regarding the design and manufacture of high-quality products, which have earned Yamaha a reputation for dependability.

Please take the time to read this manual thoroughly, so as to enjoy all advantages of your XF50E. The Owner's Manual does not only instruct you in how to operate, inspect and maintain your scooter, but also in how to safeguard yourself and others from trouble and injury.

In addition, the many tips given in this manual will help keep your scooter in the best possible condition. If you have any further questions, do not hesitate to contact your Yamaha dealer.

The Yamaha team wishes you many safe and pleasant rides. So, remember to put safety first!

Yamaha continually seeks advancements in product design and quality. Therefore, while this manual contains the most current product information available at the time of printing, there may be minor discrepancies between your scooter and this manual. If there is any question concerning this manual, please consult a Yamaha dealer.





Please read this manual carefully and completely before operating this scooter.

IMPORTANT MANUAL INFORMATION

EAU10132

Particularly important information is distinguished in this manual by the following notations:

	<p>This is the safety alert symbol. It is used to alert you to potential personal injury hazards. Obey all safety messages that follow this symbol to avoid possible injury or death.</p>
	<p>A WARNING indicates a hazardous situation which, if not avoided, could result in death or serious injury.</p>
	<p>A NOTICE indicates special precautions that must be taken to avoid damage to the vehicle or other property.</p>
TIP	<p>A TIP provides key information to make procedures easier or clearer.</p>

IMPORTANT MANUAL INFORMATION

EAUT1390

**XF50E
OWNER'S MANUAL
©2008 by Yamaha Motor Taiwan Co., Ltd.
1st edition, September 2008
All rights reserved.
Any reprinting or unauthorized use
without the written permission of
Yamaha Motor Taiwan Co., Ltd.
is expressly prohibited.
Printed in Taiwan.**

TABLE OF CONTENTS

SAFETY INFORMATION	1-1
Further safe-riding points	1-5

DESCRIPTION	2-1
Left view	2-1
Right view	2-2
Controls and instruments	2-3

INSTRUMENT AND CONTROL FUNCTIONS	3-1
Main switch/steering lock	3-1
Keyhole cover	3-2
Indicator and warning lights	3-3
Speedometer unit	3-4
Fuel gauge	3-5
Handlebar switches	3-5
Front brake lever	3-6
Rear brake lever	3-7
Fuel tank cap	3-7
Fuel	3-8
Catalytic converters	3-9
Kickstarter	3-10
Seat	3-10
Helmet holder	3-10
Storage compartment	3-11
Luggage hook	3-12

FOR YOUR SAFETY - PRE-OPERATION CHECKS	4-1
Pre-operation check list	4-2

OPERATION AND IMPORTANT RIDING POINTS	5-1
Starting the engine	5-1
Starting off	5-2
Acceleration and deceleration	5-2
Braking	5-2
Tips for reducing fuel consumption	5-3
Engine break-in	5-3
Parking	5-4

PERIODIC MAINTENANCE AND ADJUSTMENT	6-1
Periodic maintenance and lubrication chart	6-2
Removing and installing panels	6-5
Checking the spark plug	6-6
Engine oil	6-7
Final transmission oil	6-9
Coolant	6-10
Replacing the air filter element	6-11
Checking the throttle cable free play	6-12
Valve clearance	6-12
Tires	6-12
Cast wheels	6-14
Adjusting the front and rear brake lever free play	6-14
Checking the front and rear brake shoes	6-15

Checking and lubricating the throttle grip and cable	6-16
Lubricating the front and rear brake levers	6-16
Checking and lubricating the centerstand	6-17
Checking the front fork	6-17
Checking the steering	6-18
Checking the wheel bearings	6-18
Battery	6-19
Replacing the fuse	6-20
Replacing the headlight bulb	6-21
Replacing the tail/brake light bulb	6-22
Replacing a turn signal light bulb	6-22
Troubleshooting	6-23
Troubleshooting charts	6-24

SCOOTER CARE AND STORAGE	7-1
Matte color caution	7-1
Care	7-1
Storage	7-4

SPECIFICATIONS	8-1
-----------------------------	------------

CONSUMER INFORMATION	9-1
Identification numbers	9-1

TABLE OF CONTENTS

SAFETY INFORMATION

1

Be a Responsible Owner

EAU10263

As the vehicle's owner, you are responsible for the safe and proper operation of your scooter.

Scooters are single-track vehicles.

Their safe use and operation are dependent upon the use of proper riding techniques as well as the expertise of the operator. Every operator should know the following requirements before riding this scooter.

He or she should:

- Obtain thorough instructions from a competent source on all aspects of scooter operation.
- Observe the warnings and maintenance requirements in this Owner's Manual.
- Obtain qualified training in safe and proper riding techniques.
- Obtain professional technical service as indicated in this Owner's Manual and/or when made necessary by mechanical conditions.

Safe Riding

Perform the pre-operation checks each time you use the vehicle to make sure it is in safe operating condition. Failure to inspect or maintain the vehicle properly increases the possibility of an accident or equipment damage. See page 4-2 for a list of pre-operation checks.

- This scooter is designed to carry the operator and a passenger.
- The failure of motorists to detect and recognize scooters in traffic is the predominating cause of automobile/scooter accidents. Many accidents have been caused by an automobile driver who did not see the scooter. Making yourself conspicuous appears to be very effective in reducing the chance of this type of accident.

Therefore:

- Wear a brightly colored jacket.
- Use extra caution when you are approaching and passing through intersections, since

intersections are the most likely places for scooter accidents to occur.

- Ride where other motorists can see you. Avoid riding in another motorist's blind spot.
- Many accidents involve inexperienced operators. In fact, many operators who have been involved in accidents do not even have a current driver's license.
- Make sure that you are qualified and that you only lend your scooter to other qualified operators.
- Know your skills and limits. Staying within your limits may help you to avoid an accident.
- We recommend that you practice riding your scooter where there is no traffic until you have become thoroughly familiar with the scooter and all of its controls.
- Many accidents have been caused by error of the scooter operator. A

typical error made by the operator is veering wide on a turn due to excessive speed or undercornering (insufficient lean angle for the speed).

- Always obey the speed limit and never travel faster than warranted by road and traffic conditions.
- Always signal before turning or changing lanes. Make sure that other motorists can see you.
- The posture of the operator and passenger is important for proper control.
 - The operator should keep both hands on the handlebar and both feet on the operator footrests during operation to maintain control of the scooter.
 - The passenger should always hold onto the operator, the seat strap or grab bar, if equipped, with both hands and keep both feet on the passenger footrests. Never carry a passenger unless

he or she can firmly place both feet on the passenger footrests.

- Never ride under the influence of alcohol or other drugs.
- This scooter is designed for on-road use only. It is not suitable for off-road use.

Protective apparel

The majority of fatalities from scooter accidents are the result of head injuries. The use of a safety helmet is the single most critical factor in the prevention or reduction of head injuries.

- Always wear an approved helmet.
- Wear a face shield or goggles. Wind in your unprotected eyes could contribute to an impairment of vision that could delay seeing a hazard.
- The use of a jacket, substantial shoes, trousers, gloves, etc., is effective in preventing or reducing abrasions or lacerations.
- Never wear loose-fitting clothes, otherwise they could catch on the

control levers or wheels and cause injury or an accident.

- Always wear protective clothing that covers your legs, ankles, and feet. The engine or exhaust system become very hot during or after operation and can cause burns.
- A passenger should also observe the above precautions.

Avoid Carbon Monoxide Poisoning

All engine exhaust contains carbon monoxide, a deadly gas. Breathing carbon monoxide can cause headaches, dizziness, drowsiness, nausea, confusion, and eventually death.

Carbon Monoxide is a colorless, odorless, tasteless gas which may be present even if you do not see or smell any engine exhaust. Deadly levels of carbon monoxide can collect rapidly and you can quickly be overcome and unable to save yourself. Also, deadly levels of carbon monoxide can linger for hours or days in enclosed or poorly ventilated areas. If you experience any

SAFETY INFORMATION

1

symptoms of carbon monoxide poisoning, leave the area immediately, get fresh air, and SEEK MEDICAL TREATMENT.

- Do not run engine indoors. Even if you try to ventilate engine exhaust with fans or open windows and doors, carbon monoxide can rapidly reach dangerous levels.
- Do not run engine in poorly ventilated or partially enclosed areas such as barns, garages, or carports.
- Do not run engine outdoors where engine exhaust can be drawn into a building through openings such as windows and doors.

Loading

Adding accessories or cargo to your scooter can adversely affect stability and handling if the weight distribution of the scooter is changed. To avoid the possibility of an accident, use extreme caution when adding cargo or accessories to your scooter. Use extra care when

riding a scooter that has added cargo or accessories. Here, along with the information about accessories below, are some general guidelines to follow if loading cargo to your scooter:

The total weight of the operator, passenger, accessories and cargo must not exceed the maximum load limit. Operation of an overloaded vehicle could cause an accident.

<p>Maximum load: 177 kg (390 lb)</p>

When loading within this weight limit, keep the following in mind:

- Cargo and accessory weight should be kept as low and close to the scooter as possible. Securely pack your heaviest items as close to the center of the vehicle as possible and make sure to distribute the weight as evenly as possible on both sides of the scooter to minimize imbalance or instability.

- Shifting weights can create a sudden imbalance. Make sure that accessories and cargo are securely attached to the scooter before riding. Check accessory mounts and cargo restraints frequently.
- Properly adjust the suspension for your load (suspension-adjustable models only), and check the condition and pressure of your tires.
- Never attach any large or heavy items to the handlebar, front fork, or front fender. Such items can create unstable handling or a slow steering response.

This vehicle is not designed to pull a trailer or to be attached to a sidecar.

Genuine Yamaha Accessories

Choosing accessories for your vehicle is an important decision. Genuine Yamaha accessories, which are avail-

able only from a Yamaha dealer, have been designed, tested, and approved by Yamaha for use on your vehicle. Many companies with no connection to Yamaha manufacture parts and accessories or offer other modifications for Yamaha vehicles. Yamaha is not in a position to test the products that these aftermarket companies produce. Therefore, Yamaha can neither endorse nor recommend the use of accessories not sold by Yamaha or modifications not specifically recommended by Yamaha, even if sold and installed by a Yamaha dealer.

Aftermarket Parts, Accessories, and Modifications

While you may find aftermarket products similar in design and quality to genuine Yamaha accessories, recognize that some aftermarket accessories or modifications are not suitable because of potential safety hazards to you or others. Installing aftermarket products or having other modifications performed to

your vehicle that change any of the vehicle's design or operation characteristics can put you and others at greater risk of serious injury or death. You are responsible for injuries related to changes in the vehicle.

Keep the following guidelines in mind, as well as those provided under "Loading" when mounting accessories.

- Never install accessories or carry cargo that would impair the performance of your scooter. Carefully inspect the accessory before using it to make sure that it does not in any way reduce ground clearance or cornering clearance, limit suspension travel, steering travel or control operation, or obscure lights or reflectors.
- Accessories fitted to the handlebar or the front fork area can create instability due to improper weight distribution or aerodynamic changes. If accessories are added to the handlebar or front fork area,

they must be as lightweight as possible and should be kept to a minimum.

- Bulky or large accessories may seriously affect the stability of the scooter due to aerodynamic effects. Wind may attempt to lift the scooter, or the scooter may become unstable in cross winds. These accessories may also cause instability when passing or being passed by large vehicles.
- Certain accessories can displace the operator from his or her normal riding position. This improper position limits the freedom of movement of the operator and may limit control ability, therefore, such accessories are not recommended.
- Use caution when adding electrical accessories. If electrical accessories exceed the capacity of the scooter's electrical system, an elec-

SAFETY INFORMATION

tric failure could result, which could cause a dangerous loss of lights or engine power.

1

Aftermarket Tires and Rims

The tires and rims that came with your scooter were designed to match the performance capabilities and to provide the best combination of handling, braking, and comfort. Other tires, rims, sizes, and combinations may not be appropriate. Refer to page 6-12 for tire specifications and more information on replacing your tires.

EAUT2030

Further safe-riding points

- Make sure to signal clearly when making turns.
- Braking can be extremely difficult on a wet road. Avoid hard braking, because the scooter could slide. Apply the brakes slowly when stopping on a wet surface.
- Slow down as you approach a corner or turn. Once you have completed a turn, accelerate slowly.
- Be careful when passing parked cars. A driver might not see you and open a door in your path.
- Railroad crossings, streetcar rails, iron plates on road construction sites, and manhole covers become extremely slippery when wet. Slow down and cross them with caution. Keep the scooter upright, otherwise it could slide out from under you.
- The brake lining could get wet when you wash the scooter. After washing the scooter, check the brakes before riding.

- Always wear a helmet, gloves, trousers (tapered around the cuff and ankle so they do not flap), and a bright colored jacket.
- Do not carry too much luggage on the scooter. An overloaded scooter is unstable.

DESCRIPTION

EAU10410

Left view

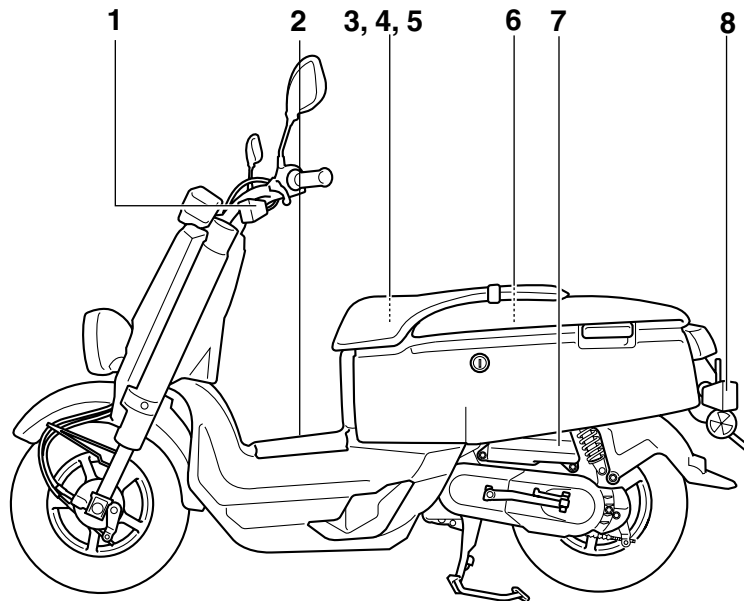

2

1. Front turn signal light (page 6-22)
2. Fuel tank cap (page 3-7)
3. Luggage hook (page 3-12)
4. Helmet holder (page 3-10)
5. Battery (page 6-19)
6. Storage compartment (page 3-11)
7. Air filter (page 6-11)
8. Rear turn signal light (page 6-22)

Right view

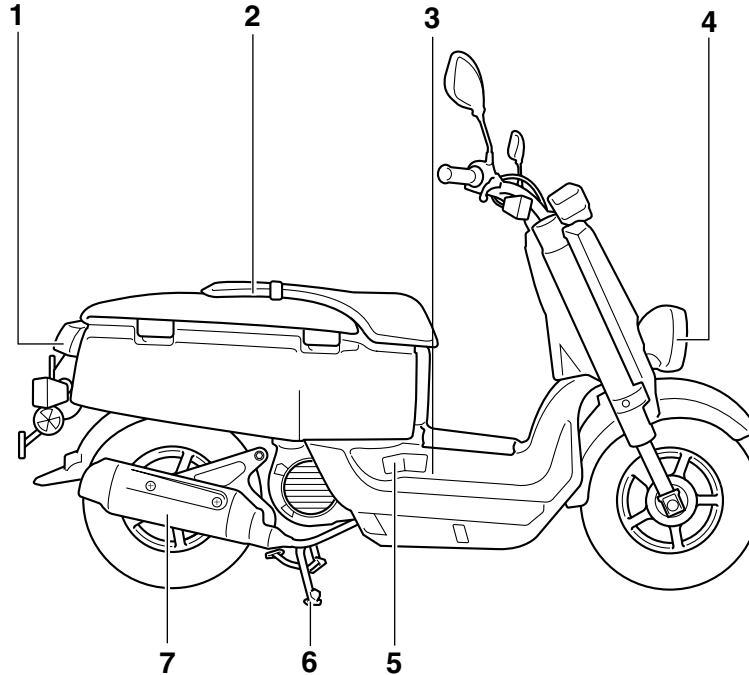

1. Tail/brake light (page 6-22)
2. Seat (page 3-10)
3. Coolant reservoir (page 6-10)
4. Headlight (page 6-21)
5. Spark plug (page 6-6)
6. Centerstand (page 6-17)
7. Muffler (page 3-9)

DESCRIPTION

EAU10430

Controls and instruments

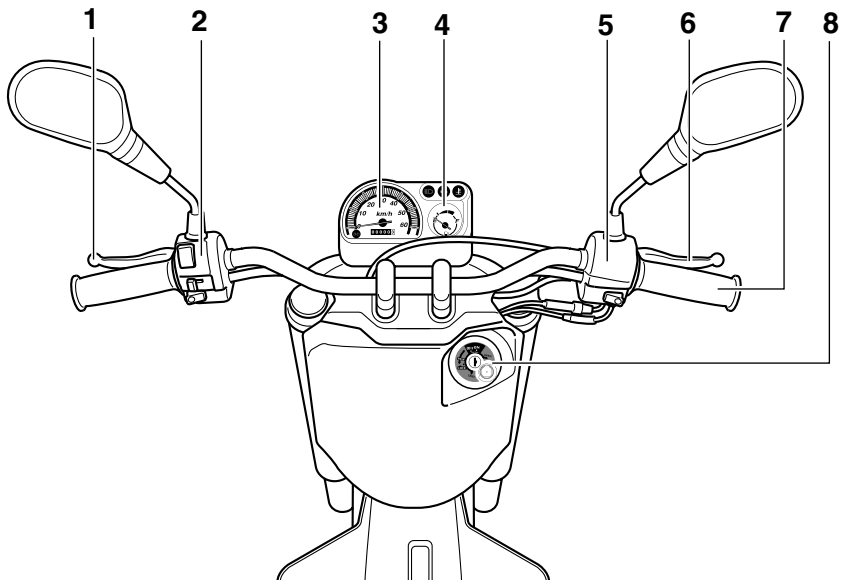

2

1. Rear brake lever (page 3-7)
2. Left handlebar switches (page 3-5)
3. Speedometer unit (page 3-4)
4. Fuel gauge (page 3-5)
5. Right handlebar switch (page 3-5)
6. Front brake lever (page 3-6)
7. Throttle grip (page 5-2)
8. Main switch/steering lock (page 3-1)

INSTRUMENT AND CONTROL FUNCTIONS

Main switch/steering lock

EAU10460

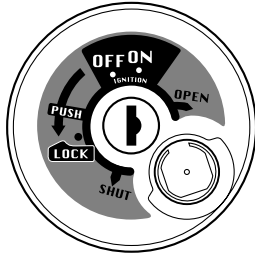

ZALM00**

The main switch/steering lock controls the ignition and lighting systems, and is used to lock the steering. The various positions are described below.

(15P5/15P8)

EAUT2270

ON

All electrical circuits are supplied with power, and the meter lighting and tail-light come on, and the engine can be started. The key cannot be removed.

TIP

The headlight comes on automatically when the engine is started and stays on until the key is turned to “OFF”.

EAUT2060

(15P6/15P7)

ON

All electrical circuits are supplied with power, and the meter lighting, taillight, and license plate light come on, and the engine can be started. The key cannot be removed.

TIP

The headlight comes on automatically when the engine is started and stays on until the key is turned to “OFF”, even if the engine stalls.

OFF

All electrical systems are off. The key can be removed.

EAU10661

EWA10061

WARNING

Never turn the key to “OFF” or “LOCK” while the vehicle is moving. Otherwise the electrical systems will be switched off, which may result in loss of control or an accident.

INSTRUMENT AND CONTROL FUNCTIONS

LOCK

EAU10681

The steering is locked, and all electrical systems are off. The key can be removed.

To lock the steering

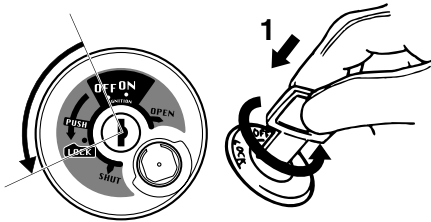

ZALM00**

1. Push.

1. Turn the handlebars all the way to the left.
2. Push the key in from the "OFF" position, and then turn it to "LOCK" while still pushing it.
3. Remove the key.

To unlock the steering

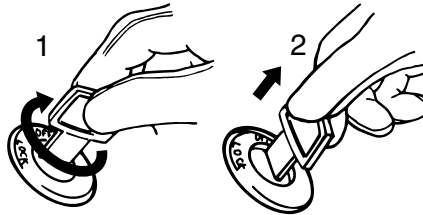

ZALM00**

1. Turn.
2. Release.

Push the key in, and then turn it to "OFF" while still pushing it.

Keyhole cover

EAUT2121

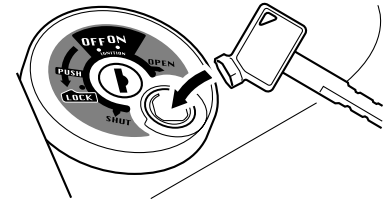

ZALM00**

To close the keyhole cover

Insert the key bow into the keyhole cover receptacle as shown, and then turn the key to "SHUT" to close the cover.

To open the keyhole cover

Insert the key bow into the keyhole cover receptacle as shown, and then turn the key to "OPEN" to open the cover.

INSTRUMENT AND CONTROL FUNCTIONS

Indicator and warning lights

EAU11003

(15P5/15P7/15P8)

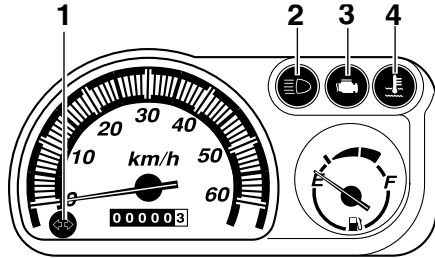

ZAJM00**

(15P6)

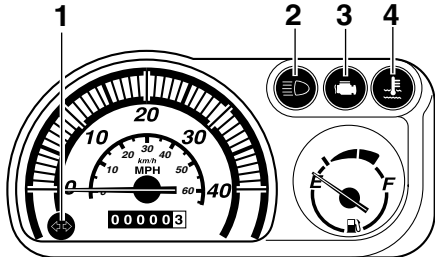

ZAJM00**

1. Turn signal indicator light "↔"
2. High beam indicator light "≡D"
3. Engine trouble warning light "⚡"
4. Coolant temperature warning light "🌡️"

Turn signal indicator light "↔"

EAU11020

This indicator light flashes when the turn signal switch is pushed to the left or right.

High beam indicator light "≡D"

EAU11080

This indicator light comes on when the high beam of the headlight is switched on.

Coolant temperature warning light

EAU11442

This warning light comes on if the engine overheats. If this occurs, stop the engine immediately and allow the engine to cool.

The electrical circuit of the warning light can be checked by turning the key to "ON".

If the warning light does not come on for a few seconds, then go off, have a Yamaha dealer check the electrical circuit.

NOTICE

ECA10021

Do not continue to operate the engine if it is overheating.

TIP

- For radiator-fan-equipped vehicles, the radiator fan(s) automatically switch on or off according to the coolant temperature in the radiator.
- If the engine overheats, see page 6-25 for further instructions.

INSTRUMENT AND CONTROL FUNCTIONS

3

EAUT1932

Engine trouble warning light “”

This warning light flashes or stays on if an electrical circuit monitoring the engine is not working correctly. If this occurs, have a Yamaha dealer check the self-diagnosis system.

The electrical circuit of the warning light can be checked by turning the key to “ON”. If the warning light does not come on for a few seconds, then go off, have a Yamaha dealer check the electrical circuit.

Speedometer unit

EAUT2310

(15P5/15P7/15P8)

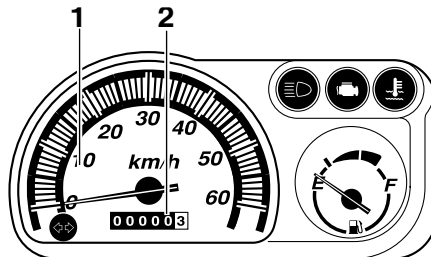

ZAJM00**

The speedometer unit is equipped with a speedometer and an odometer. The speedometer shows the riding speed. The odometer shows the total distance traveled.

TIP

For the U.K.: The odometer units are displayed in miles.

(15P6)

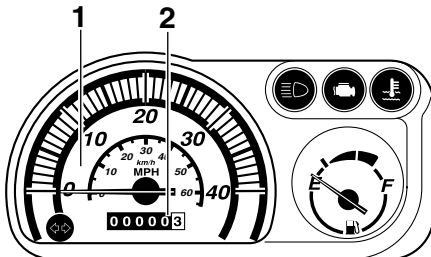

ZAJM00**

1. Speedometer
2. Odometer

INSTRUMENT AND CONTROL FUNCTIONS

Fuel gauge

(15P5/15P7/15P8)

EAU12150

The fuel gauge indicates the amount of fuel in the fuel tank. The needle moves towards "E" (Empty) as the fuel level decreases. When the needle reaches the red line, refuel as soon as possible.

TIP

Do not allow the fuel tank to empty itself completely.

Handlebar switches

EAU12347

Left

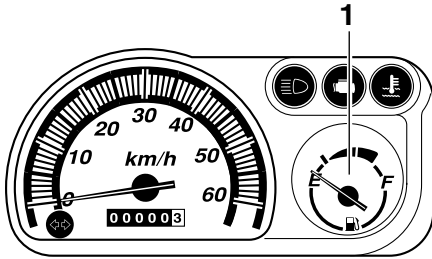

ZAJUM00**

(15P6)

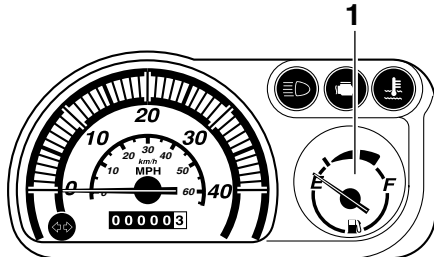

ZAJUM00**

1. Fuel gauge

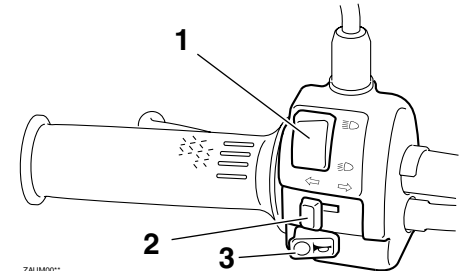

ZAJUM00**

1. Dimmer switch "☀️/☀️/☀️/☀️"
2. Turn signal switch "↔️↔️"
3. Horn switch "🔊"

INSTRUMENT AND CONTROL FUNCTIONS

Right

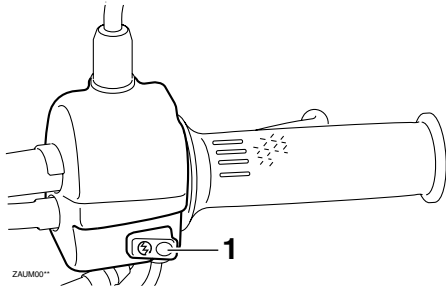

1. Start switch "⚡⚙️"

Dimmer switch "☰☷☷☷"

EAU12400

Set this switch to "☰☷" for the high beam and to "☷☷" for the low beam.

Turn signal switch "⬅️➡️"

EAU12460

To signal a right-hand turn, push this switch to "➡️". To signal a left-hand turn, push this switch to "⬅️". When released, the switch returns to the center position. To cancel the turn signal lights, push the switch in after it has returned to the center position.

Horn switch "📢"

EAU12500

Press this switch to sound the horn.

Start switch "⚡⚙️"

EAUM1132

Push this switch while applying the front or rear brake to crank the engine with the starter. See page 5-1 for starting instructions prior to starting the engine.

Front brake lever

EAU12900

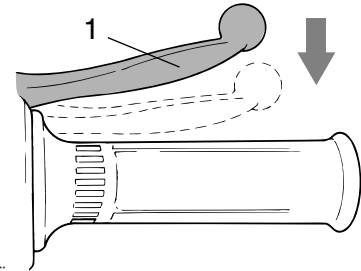

1. Front brake lever

The front brake lever is located on the right handlebar grip. To apply the front brake, pull this lever toward the handlebar grip.

INSTRUMENT AND CONTROL FUNCTIONS

Rear brake lever

EAU12950

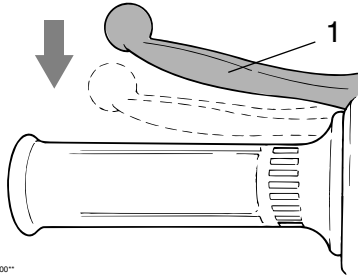

1. Rear brake lever

The rear brake lever is located on the left handlebar grip. To apply the rear brake, pull this lever toward the handlebar grip.

Fuel tank cap

EAUT2281

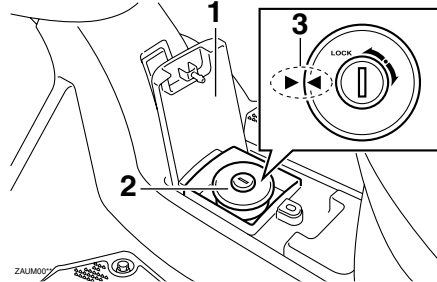

1. Fuel tank cap lid
2. Fuel tank cap
3. Match marks

To remove the fuel tank cap

Open the lid, insert the key into the lock, and then turn it 1/4 turn clockwise. The lock will be released and the fuel tank cap can be removed.

To install the fuel tank cap

1. Insert the fuel tank cap into the tank opening with the key inserted in the lock and the match marks aligned.

2. Turn the key counterclockwise to the original position, remove it, and then close the lid.

TIP

The fuel tank cap cannot be installed unless the key is in the lock. In addition, the key cannot be removed if the cap is not properly installed and locked.

3

EWA10131

WARNING

Make sure that the fuel tank cap is properly installed before riding. Leaking fuel is a fire hazard.

INSTRUMENT AND CONTROL FUNCTIONS

Fuel

EAU13212

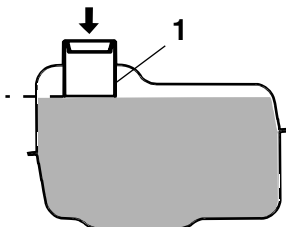

ZAJM00*

1. Fuel tank filler tube

Make sure there is sufficient gasoline in the tank.

EWA10881

WARNING

Gasoline and gasoline vapors are extremely flammable. To avoid fires and explosions and to reduce the risk of injury when refueling, follow these instructions.

1. Before refueling, turn off the engine and be sure that no one is sitting on the vehicle. Never refuel while

smoking, or while in the vicinity of sparks, open flames, or other sources of ignition such as the pilot lights of water heaters and clothes dryers.

2. Do not overfill the fuel tank. Stop filling when the fuel reaches the bottom of the filler tube. Because fuel expands when it heats up, heat from the engine or the sun can cause fuel to spill out of the fuel tank.
3. Wipe up any spilled fuel immediately. **NOTICE: Immediately wipe off spilled fuel with a clean, dry, soft cloth, since fuel may deteriorate painted surfaces or plastic parts.**^[ECA10071]
4. Be sure to securely close the fuel tank cap.

EWA15151

WARNING

Gasoline is poisonous and can cause injury or death. Handle gasoline with care. Never siphon gasoline by mouth. If you should swallow

some gasoline or inhale a lot of gasoline vapor, or get some gasoline in your eyes, see your doctor immediately. If gasoline spills on your skin, wash with soap and water. If gasoline spills on your clothing, change your clothes.

EAU33520

Recommended fuel:
REGULAR UNLEADED GASOLINE
ONLY
Fuel tank capacity:
4.5 L (1.19 US gal) (0.99 Imp.gal)

ECA11400

NOTICE

Use only unleaded gasoline. The use of leaded gasoline will cause severe damage to internal engine parts, such as the valves and piston rings, as well as to the exhaust system.

Your Yamaha engine has been designed to use regular unleaded gasoline with a research octane number of 91 or higher. If knocking (or pinging) occurs, use a

gasoline of a different brand or premium unleaded fuel. Use of unleaded fuel will extend spark plug life and reduce maintenance costs.

EAU13445

ECA10701

Catalytic converters

This vehicle is equipped with catalytic converters in the exhaust system.

EWA10862

WARNING

The exhaust system is hot after operation. To prevent a fire hazard or burns:

- Do not park the vehicle near possible fire hazards such as grass or other materials that easily burn.
- Park the vehicle in a place where pedestrians or children are not likely to touch the hot exhaust system.
- Make sure that the exhaust system has cooled down before doing any maintenance work.
- Do not allow the engine to idle more than a few minutes. Long idling can cause a build-up of heat.

NOTICE

Use only unleaded gasoline. The use of leaded gasoline will cause unreparable damage to the catalytic converter.

INSTRUMENT AND CONTROL FUNCTIONS

Kickstarter

EAU13680

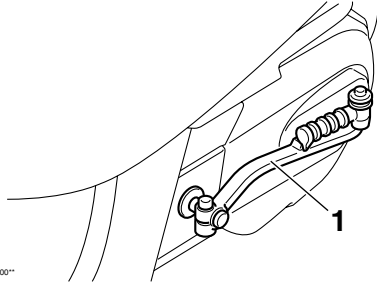

1. Kickstarter

To start the engine, fold out the kickstarter lever, move it down lightly with your foot until the gears engage, and then push it down smoothly but forcefully.

Seat

EAU13891

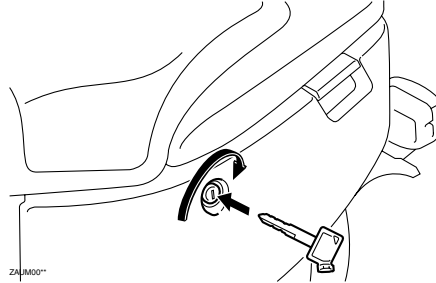

To open the seat

1. Insert the key in the lock, and then turn it as shown.
2. Fold the seat up.

To close the seat

1. Fold the seat down, and then push it down to lock it in place.
2. Remove the key.

TIP

Make sure that the seat is properly secured before riding.

Helmet holder

EAUT2041

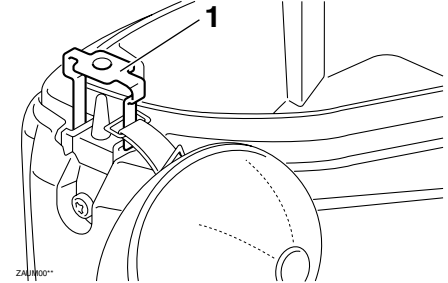

1. Helmet holder

The helmet holder is located under the seat.

To secure a helmet to the helmet holder

1. Open the seat. (See page 3-10.)
2. Pull the helmet holder up.
3. Attach the helmet to the helmet holder and then push the helmet holder down.
4. Securely close the seat. **WARNING!** Never ride with a helmet attached to the helmet holder, since the

INSTRUMENT AND CONTROL FUNCTIONS

helmet may hit objects, causing loss of control and possibly an accident.^[EWA10161]

To release the helmet from the helmet holder

1. Open the seat, pull the helmet holder up and remove the helmet from the helmet holder, and then push the helmet holder down.
2. Securely close the seat.

Storage compartment

EAUT2470

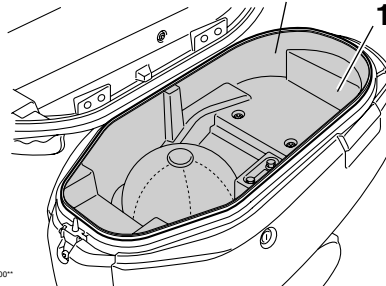

1. Storage compartment

The storage compartment is located under the seat. (See page 3-10.)

EWA10961

! WARNING

- Do not exceed the load limit of 5 kg (11 lb) for the storage compartment.
- Do not exceed the maximum load of 177 kg (390 lb) for the vehicle.

When storing the owner's manual or other documents in the storage compartment, be sure to wrap them in a plastic bag so that they will not get wet. When washing the vehicle, be careful not to let any water enter the storage compartment.

EWA1060

! WARNING

The lid of the storage compartment is not a seat. Never sit or carry a passenger on this lid.

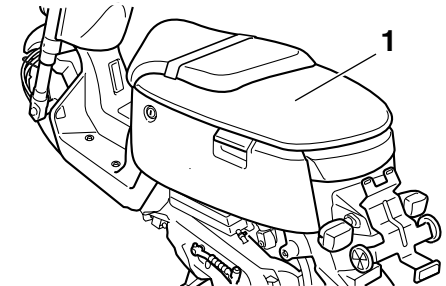

1. Storage compartment lid

INSTRUMENT AND CONTROL FUNCTIONS

EAUT2051

Luggage hook

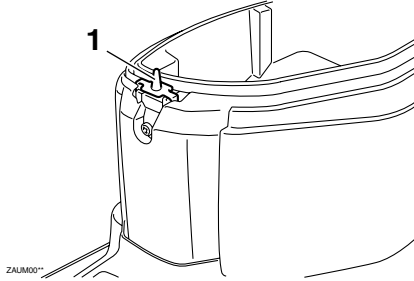

3

1. Luggage hook

EWAT1031

WARNING

- Do not exceed the load limit of 1.0 kg (2.2 lb) for the luggage hook.
- Do not exceed the maximum load of 177 kg (390 lb) for the vehicle.

The luggage hook is located under the seat. (See page 3-10.)

FOR YOUR SAFETY - PRE-OPERATION CHECKS

EAU15596

Inspect your vehicle each time you use it to make sure the vehicle is in safe operating condition. Always follow the inspection and maintenance procedures and schedules described in the Owner's Manual.

EWA11151

WARNING

Failure to inspect or maintain the vehicle properly increases the possibility of an accident or equipment damage. Do not operate the vehicle if you find any problem. If a problem cannot be corrected by the procedures provided in this manual, have the vehicle inspected by a Yamaha dealer.

Before using this vehicle, check the following points:

FOR YOUR SAFETY - PRE-OPERATION CHECKS

EAU15605

Pre-operation check list

ITEM	CHECKS	PAGE
Fuel	<ul style="list-style-type: none">• Check fuel level in fuel tank.• Refuel if necessary.• Check fuel line for leakage.	3-5, 3-7~3-8
Engine oil	<ul style="list-style-type: none">• Check oil level in engine.• If necessary, add recommended oil to specified level.• Check vehicle for oil leakage.	6-7
Final transmission oil	<ul style="list-style-type: none">• Check vehicle for oil leakage.	6-9
Coolant	<ul style="list-style-type: none">• Check coolant level in reservoir• If necessary, add recommended coolant to specified level.• Check cooling system for leakage.	6-10
Front brake	<ul style="list-style-type: none">• Check operation.• Lubricate cable if necessary.• Check lever free play.• Adjust if necessary.	6-14~6-15
Rear brake	<ul style="list-style-type: none">• Check operation.• Lubricate cable if necessary.• Check lever free play.• Adjust if necessary.	6-14~6-15
Throttle grip	<ul style="list-style-type: none">• Make sure that operation is smooth.• Check cable free play.• If necessary, have Yamaha dealer adjust cable free play and lubricate cable and grip housing.	6-16
Wheels and tires	<ul style="list-style-type: none">• Check for damage.• Check tire condition and tread depth.• Check air pressure.• Correct if necessary.	6-12~6-14
Brake levers	<ul style="list-style-type: none">• Make sure that operation is smooth.• Lubricate lever pivoting points if necessary.	6-16

4

FOR YOUR SAFETY - PRE-OPERATION CHECKS

ITEM	CHECKS	PAGE
Centerstand	<ul style="list-style-type: none">• Make sure that operation is smooth.• Lubricate pivots if necessary.	6-17
Chassis fasteners	<ul style="list-style-type: none">• Make sure that all nuts, bolts and screws are properly tightened.• Tighten if necessary.	-
Instruments, lights, signals and switches	<ul style="list-style-type: none">• Check operation.• Correct if necessary.	3-3, 3-5

OPERATION AND IMPORTANT RIDING POINTS

Read the Owner's Manual carefully to become familiar with all controls. If there is a control or function you do not understand, ask your Yamaha dealer.

EAU15951

EWA10271

WARNING

Failure to familiarize yourself with the controls can lead to loss of control, which could cause an accident or injury.

EAU45310

TIP

This model is equipped with a lean angle sensor to stop the engine in case of a turnover. To start the engine after a turnover, be sure to turn the main switch to "OFF" and then to "ON". Failing to do so will prevent the engine from starting even though the engine will crank when pushing the start switch.

Starting the engine

EAUT2251

ECA10250

NOTICE

See page 5-3 for engine break-in instructions prior to operating the vehicle for the first time.

1. Turn the key to "ON".

ECAT1070

NOTICE

The engine trouble warning light and coolant temperature warning light should come on for a few seconds, then go off. If these warning lights do not go off, have a Yamaha dealer check their electrical circuits.

2. Close the throttle completely.
3. Start the engine by pushing the start switch while applying the front or rear brake. **NOTICE: For maximum engine life, never accelerate hard when the engine is cold!**^[ECA11041]

If the engine does not start, release the start switch, wait a few seconds, and then try again. Each starting attempt should be as short as possible to preserve the battery. Do not crank the engine more than 5 seconds on any one attempt. If the engine does not start with the starter motor, try using the kickstarter.

OPERATION AND IMPORTANT RIDING POINTS

Starting off

EAU16761

TIP

Before starting off, allow the engine to warm up.

1. While pulling the rear brake lever with your left hand and holding the grab bar with your right hand, push the scooter off the centerstand.
2. Sit astride the seat, and then adjust the rear view mirrors.
3. Switch the turn signals on.
4. Check for oncoming traffic, and then slowly turn the throttle grip (on the right) in order to take off.
5. Switch the turn signals off.

Acceleration and deceleration

EAU16780

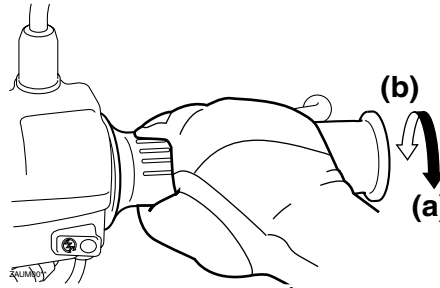

The speed can be adjusted by opening and closing the throttle. To increase the speed, turn the throttle grip in direction (a). To reduce the speed, turn the throttle grip in direction (b).

Braking

EAU16793

EWA10300

WARNING

- Avoid braking hard or suddenly (especially when leaning over to one side), otherwise the scooter may skid or overturn.
- Railroad crossings, streetcar rails, iron plates on road construction sites, and manhole covers become extremely slippery when wet. Therefore, slow down when approaching such areas and cross them with caution.
- Keep in mind that braking on a wet road is much more difficult.
- Ride slowly down a hill, as braking downhill can be very difficult.

1. Close the throttle completely.
2. Apply both front and rear brakes simultaneously while gradually increasing the pressure.

OPERATION AND IMPORTANT RIDING POINTS

Tips for reducing fuel consumption

EAU16820

Fuel consumption depends largely on your riding style. Consider the following tips to reduce fuel consumption:

- Avoid high engine speeds during acceleration.
- Avoid high engine speeds with no load on the engine.
- Turn the engine off instead of letting it idle for an extended length of time (e.g., in traffic jams, at traffic lights or at railroad crossings).

Engine break-in

EAU16830

There is never a more important period in the life of your engine than the period between 0 and 1000 km (600 mi). For this reason, you should read the following material carefully.

Since the engine is brand new, do not put an excessive load on it for the first 1000 km (600 mi). The various parts in the engine wear and polish themselves to the correct operating clearances. During this period, prolonged full-throttle operation or any condition that might result in engine overheating must be avoided.

0 ~ 150 km (0 ~ 90 mi)

EAU16951

Avoid prolonged operation above 1/3 throttle.

After every hour of operation, stop the engine, and then let it cool for five to ten minutes.

Vary the engine speed from time to time. Do not operate the engine at one set throttle position.

150 ~ 500 km (90 ~ 300 mi)

Avoid prolonged operation above 1/2 throttle.

Rev the engine freely through the gears, but do not use full throttle at any time.

500 ~ 1000 km (300 ~ 600 mi)

Avoid prolonged operation above 3/4 throttle. **NOTICE: After 1000 km (600 mi) of operation, the engine oil must be changed and the oil strainer cleaned.**^[ECA10351]

1000 km (600 mi) and beyond

Avoid prolonged full-throttle operation. Vary the speed occasionally.

ECA10270

NOTICE

If any engine trouble should occur during the engine break-in period, immediately have a Yamaha dealer check the vehicle.

EAU17213

Parking

When parking, stop the engine, and then remove the key from the main switch.

EWA10311

WARNING

- Since the engine and exhaust system can become very hot, park in a place where pedestrians or children are not likely to touch them and be burned.
 - Do not park on a slope or on soft ground, otherwise the vehicle may overturn, increasing the risk of a fuel leak and fire.
 - Do not park near grass or other flammable materials which might catch fire.
-

PERIODIC MAINTENANCE AND ADJUSTMENT

EAU17281

Periodic inspection, adjustment, and lubrication will keep your vehicle in the safest and most efficient condition possible. Safety is an obligation of the vehicle owner/operator. The most important points of vehicle inspection, adjustment, and lubrication are explained on the following pages.

The intervals given in the periodic maintenance and lubrication chart should be simply considered as a general guide under normal riding conditions. However, depending on the weather, terrain, geographical location, and individual use, the maintenance intervals may need to be shortened.

EWA10321

WARNING

Failure to properly maintain the vehicle or performing maintenance activities incorrectly may increase your risk of injury or death during service or while using the vehicle. If you are not familiar with vehicle service, have a Yamaha dealer perform service.

EWA15121

WARNING

Turn off the engine when performing maintenance unless otherwise specified.

- A running engine has moving parts that can catch on body parts or clothing and electrical parts that can cause shocks or fires.
 - Running the engine while servicing can lead to eye injury, burns, fire, or carbon monoxide poisoning - possibly leading to death. See page 1-1 for more information about carbon monoxide.
-

Yamaha dealer for proper maintenance intervals.

EWA10330

WARNING

This scooter is designed for use on paved roads only. If this scooter is operated in abnormally dusty, muddy or wet conditions, the air filter element should be cleaned or replaced more frequently, otherwise rapid engine wear may result. Consult a

PERIODIC MAINTENANCE AND ADJUSTMENT

EAU17715

Periodic maintenance and lubrication chart

TIP

- The annual checks must be performed every year, except if a kilometer-based maintenance, or for the UK, a mileage-based maintenance, is performed instead.
- From 30000 km (17500 mi), repeat the maintenance intervals starting from 6000 km (3500 mi).
- Items marked with an asterisk should be performed by a Yamaha dealer as they require special tools, data and technical skills.

NO.	ITEM	CHECK OR MAINTENANCE JOB	ODOMETER READING					ANNUAL CHECK
			1000 km (600 mi)	6000 km (3500 mi)	12000 km (7000 mi)	18000 km (10500 mi)	24000 km (14000 mi)	
1	* Fuel line	• Check fuel hoses and vacuum hose for cracks or damage.		√	√	√	√	√
2	Spark plug	• Check condition. • Clean and regap.		√		√		
		• Replace.			√		√	
3	* Valves	• Check and adjust valve clearance when engine is cold.		√	√	√	√	
4	* Air filter element	• Replace.		√	√	√	√	√
5	* Front brake	• Check operation and adjust brake lever free play.	√	√	√	√	√	√
		• Replace brake shoes.	Whenever worn to the limit					
6	* Rear brake	• Check operation and adjust brake lever free play.	√	√	√	√	√	√
		• Replace brake shoes.	Whenever worn to the limit					
7	* Wheels	• Check runout and for damage.		√	√	√	√	
8	* Tires	• Check tread depth and for damage. • Replace if necessary. • Check air pressure. • Correct if necessary.		√	√	√	√	√
9	* Wheel bearings	• Check bearing for looseness or damage.		√	√	√	√	

PERIODIC MAINTENANCE AND ADJUSTMENT

NO.	ITEM	CHECK OR MAINTENANCE JOB	ODOMETER READING					ANNUAL CHECK
			1000 km (600 mi)	6000 km (3500 mi)	12000 km (7000 mi)	18000 km (10500 mi)	24000 km (14000 mi)	
10	* Steering bearings	<ul style="list-style-type: none"> • Check bearing assemblies for looseness. • Moderately repack with lithium-soap-based grease every 12000 km (7000 mi) or 24 months. 	√	√	Repack.	√	Repack.	√
11	* Chassis fasteners	<ul style="list-style-type: none"> • Make sure that all nuts, bolts and screws are properly tightened. 		√	√	√	√	√
12	Front brake lever pivot shaft	<ul style="list-style-type: none"> • Lubricate with lithium-soap-based grease. 		√	√	√	√	√
13	Rear brake lever pivot shaft	<ul style="list-style-type: none"> • Lubricate with lithium-soap-based grease. 		√	√	√	√	√
14	Centerstand	<ul style="list-style-type: none"> • Check operation. • Lubricate. 		√	√	√	√	√
15	* Front fork	<ul style="list-style-type: none"> • Check operation and for oil leakage. 		√	√	√	√	
16	* Shock absorber assembly	<ul style="list-style-type: none"> • Check operation and shock absorber for oil leakage. 		√	√	√	√	
17	* Fuel injection	<ul style="list-style-type: none"> • Check engine idle speed. 	√	√	√	√	√	√
18	Engine oil	<ul style="list-style-type: none"> • Change. (See page 6-7.) • Check oil level and vehicle for oil leakage. 	√	Every 3000 km (1750 mi)				
19	* Engine oil strainer	<ul style="list-style-type: none"> • Clean. 	√	Every 6000 km (3500 mi)				
20	* Cooling system	<ul style="list-style-type: none"> • Check coolant level and vehicle for coolant leakage. • Change. 		√	√	√	√	√
			Every 3 years					
21	Final transmission oil	<ul style="list-style-type: none"> • Check vehicle for oil leakage. • Change. 	√	√		√		
			√	√	√	√	√	
22	* V-belt	<ul style="list-style-type: none"> • Replace. 	Every 10000 km (6000 mi)					
23	* Front and rear brake switches	<ul style="list-style-type: none"> • Check operation. 	√	√	√	√	√	√
24	Moving parts and cables	<ul style="list-style-type: none"> • Lubricate. 		√	√	√	√	√

PERIODIC MAINTENANCE AND ADJUSTMENT

NO.	ITEM	CHECK OR MAINTENANCE JOB	ODOMETER READING					ANNUAL CHECK
			1000 km (600 mi)	6000 km (3500 mi)	12000 km (7000 mi)	18000 km (10500 mi)	24000 km (14000 mi)	
25	* Throttle grip housing and cable	<ul style="list-style-type: none"> • Check operation and free play. • Adjust the throttle cable free play if necessary. • Lubricate the throttle grip housing and cable. 		√	√	√	√	√
26	* Air induction system	<ul style="list-style-type: none"> • Check the air cut-off valve, reed valve, and hose for damage. • Replace the entire air induction system if necessary. 		√	√	√	√	√
27	* Lights, signals and switches	<ul style="list-style-type: none"> • Check operation. • Adjust headlight beam. 	√	√	√	√	√	√

PERIODIC MAINTENANCE AND ADJUSTMENT

Removing and installing panels

EAU18771

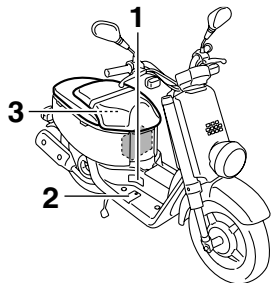

ZAUM00**

1. Panel A
2. Panel B
3. Panel C

The panels shown need to be removed to perform some of the maintenance jobs described in this chapter. Refer to this section each time a panel needs to be removed and installed.

Panel A

To remove the panel

Slide the panel backward, and then pull it out as shown.

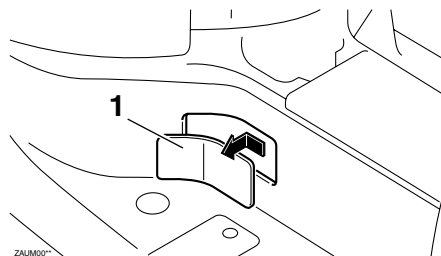

ZAUM00**

1. Panel A

To install the panel

Place and slide the panel into the original position.

EAUT2100

Panel B

To remove the panel

Remove the screw, and then take the panel off.

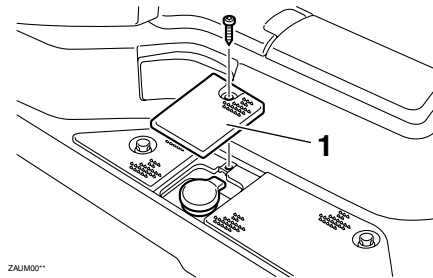

ZAUM00**

1. Panel B

To install the panel

Place the panel in the original position, and then install the screw.

PERIODIC MAINTENANCE AND ADJUSTMENT

Panel C

To remove the panel

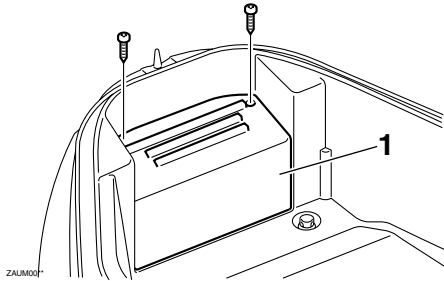

1. Panel C

1. Open the seat. (See page 3-10.)
2. Remove the screws, and then take the panel off.

To install the panel

Place the panel in the original position, and then install the screws.

Checking the spark plug

EAUT2070

The spark plug is an important engine component, which is easy to check. Since heat and deposits will cause any spark plug to slowly erode, the spark plug should be removed and checked in accordance with the periodic maintenance and lubrication chart. In addition, the condition of the spark plug can reveal the condition of the engine.

To remove the spark plug

1. Remove panel A. (See page 6-5.)
2. Remove the spark plug cap.

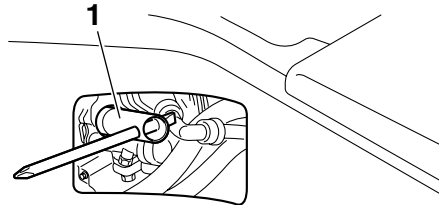

1. Spark plug wrench

3. Remove the spark plug as shown, with a spark plug wrench available at a Yamaha dealer.

To check the spark plug

1. Check that the porcelain insulator around the center electrode of the spark plug is a medium-to-light tan (the ideal color when the vehicle is ridden normally).

TIP

If the spark plug shows a distinctly different color, the engine could be operating improperly. Do not attempt to diagnose such problems yourself. Instead, have a Yamaha dealer check the vehicle.

2. Check the spark plug for electrode erosion and excessive carbon or other deposits, and replace it if necessary.

Specified spark plug:
CR7E (NGK)

PERIODIC MAINTENANCE AND ADJUSTMENT

EAUT2592

To install the spark plug

1. Measure the spark plug gap with a wire thickness gauge and, if necessary, adjust the gap to specification.

Spark plug gap:

0.7 ~ 0.8 mm (0.028 ~ 0.031 in)

2. Clean the surface of the spark plug gasket and its mating surface, and then wipe off any grime from the spark plug threads.
3. Install the spark plug with the spark plug wrench, and then tighten it to the specified torque.

Tightening torque:

Spark plug:

13 Nm (1.3 m • kgf, 9.4ft • lbf)

TIP

If a torque wrench is not available when installing a spark plug, a good estimate of the correct torque is 1/4~1/2 turn past finger tight. However, the spark plug

should be tightened to the specified torque as soon as possible.

4. Install the spark plug cap.
5. Install the panel.

Engine oil

The engine oil level should be checked before each ride. In addition, the oil must be changed and the oil strainer cleaned at the intervals specified in the periodic maintenance and lubrication chart.

To check the engine oil level

1. Place the vehicle on the centerstand. A slight tilt to the side can result in a false reading.
2. Start the engine, warm it up for several minutes, and then turn it off.

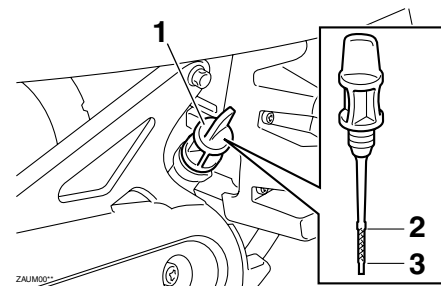

1. Engine oil filler cap
2. Maximum level mark
3. Minimum level mark

PERIODIC MAINTENANCE AND ADJUSTMENT

3. Wait a few minutes until the oil settles, remove the oil filler cap, wipe the dipstick clean, insert it back into the oil filler hole (without screwing it in), and then remove it again to check the oil level.

TIP

The engine oil should be between the minimum and maximum level marks.

4. If the engine oil is below the minimum level mark, add sufficient oil of the recommended type to raise it to the correct level.
5. Insert the dipstick into the oil filler hole, and then tighten the oil filler cap.

To change the engine oil

1. Start the engine, warm it up for several minutes, and then turn it off.
2. Place an oil pan under the engine to collect the used oil.

3. Remove the engine oil filler cap and the engine oil drain bolt to drain the oil from the crankcase.

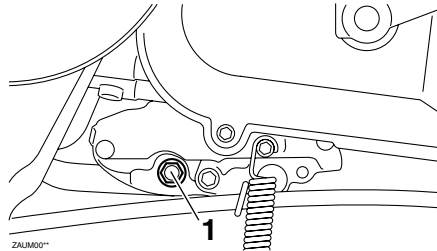

1. Engine oil drain bolt

4. Install the engine oil drain bolt, and then tighten it to the specified torque.

Tightening torque:

Engine oil drain bolt:
23 Nm (2.3 m • kgf, 16.6 ft • lbf)

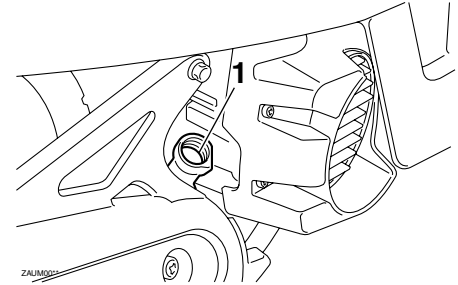

1. Oil filler hole

5. Refill with the specified amount of the recommended engine oil, and then install and tighten the oil filler cap.

Recommended engine oil:

See page 8-1.

Oil change quantity:

0.78 L (0.82 US qt, 0.69 Imp.qt)

ECA11670

NOTICE

- Do not use oils with a diesel specification of "CD" or oils of a higher quality than specified. In

PERIODIC MAINTENANCE AND ADJUSTMENT

addition, do not use oils labeled “ENERGY CONSERVING II” or higher.

- Be sure no foreign material enters the crankcase.

6. Start the engine, and then let it idle for several minutes while checking it for oil leakage. If oil is leaking, immediately turn the engine off and check for the cause.
7. Turn the engine off, and then check the oil level and correct it if necessary.

Final transmission oil

EAUT1561

The final transmission case must be checked for oil leakage before each ride. If any leakage is found, have a Yamaha dealer check and repair the scooter. In addition, the final transmission oil must be changed as follows at the intervals specified in the periodic maintenance and lubrication chart.

1. Start the engine, warm it up by riding the scooter for several minutes, and then stop the engine.
2. Place the scooter on the centerstand.
3. Place an oil pan under the final transmission case to collect the used oil.

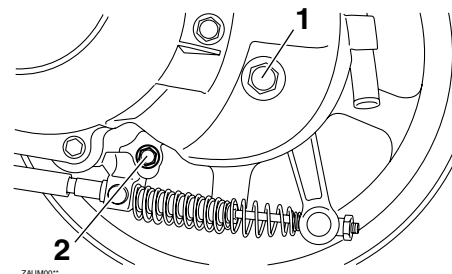

1. Final transmission oil filler bolt
2. Final transmission oil drain bolt

4. Remove the oil filler bolt and drain bolt to drain the oil from the final transmission case.
5. Install the final transmission oil drain bolt, and then tighten it to the specified torque.

Tightening torque:

Final transmission oil drain bolt:
13 Nm (1.3 m • kgf, 9.4 ft • lbf)

6. Refill with the specified amount of the recommended final transmission oil, and then install the oil filler bolt and tighten it to the specified

PERIODIC MAINTENANCE AND ADJUSTMENT

torque. **WARNING! Make sure that no foreign material enters the final transmission case. Make sure that no oil gets on the tire or wheel.**^[EWA11311]

Tightening torque:

Final transmission oil filler bolt:
23 Nm (2.3 m • kgf, 16.6 ft • lbf)

Recommended final transmission oil:

See page 8-1.

Oil quantity:

0.10 L (0.11 US qt, 0.09 Imp.qt)

7. Check the final transmission case for oil leakage. If oil is leaking, check for the cause.

Coolant

The coolant level should be checked before each ride. In addition, the coolant must be changed at the intervals specified in the periodic maintenance and lubrication chart.

To check the coolant level

The coolant level should be checked as follows before each ride. In addition, the coolant must be changed at the intervals specified in the periodic maintenance and lubrication chart.

1. Place the vehicle on the centerstand.

TIP

- The coolant level must be checked on a cold engine since the level varies with engine temperature.
- Make sure that the vehicle is positioned straight up when checking the coolant level. A slight tilt to the side can result in a false reading.

EAU20070

2. Check the coolant level in the coolant reservoir.

TIP

The coolant should be between the minimum and maximum level marks.

EAUT1523

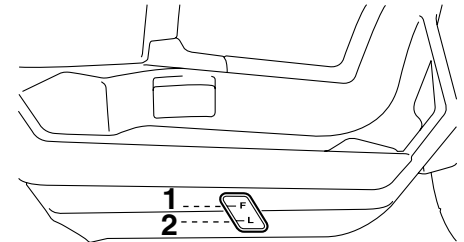

ZAJUM007*

1. Maximum level mark
2. Minimum level mark

PERIODIC MAINTENANCE AND ADJUSTMENT

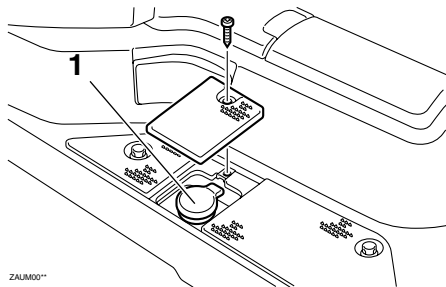

1. Coolant reservoir cap

3. If the coolant is at or below the minimum level mark, remove panel B and the reservoir cap. (See page 6-5.) **WARNING! Remove only the coolant reservoir cap. Never attempt to remove the radiator cap when the engine is hot.**^[EWA15161]

4. Add coolant or distilled water to raise the coolant to the maximum level mark, and install the coolant reservoir cap and the panel.

NOTICE: If coolant is not available, use distilled water or soft tap water instead. Do not use hard water or salt water since it is

harmful to the engine. If water has been used instead of coolant, replace it with coolant as soon as possible, otherwise the cooling system will not be protected against frost and corrosion. If water has been added to the coolant, have a Yamaha dealer check the antifreeze content of the coolant as soon as possible, otherwise the effectiveness of the coolant will be reduced.^[ECA10472]

Coolant reservoir capacity:
0.26 L (0.27 US qt, 0.23 Imp.qt)

EAUT1990

Replacing the air filter element

The air filter element must be replaced and the check hoses must be cleaned at the intervals specified in the periodic maintenance and lubrication chart. Have a Yamaha dealer replace the air filter element.

PERIODIC MAINTENANCE AND ADJUSTMENT

Checking the throttle cable free play

EAU21382

The throttle cable free play should measure 1.5~3.5 mm (0.06~0.14 in) at the throttle grip. Periodically check the throttle cable free play and, if necessary, have a Yamaha dealer adjust it.

Valve clearance

EAU21401

The valve clearance changes with use, resulting in improper air-fuel mixture and/or engine noise. To prevent this from occurring, the valve clearance must be adjusted by a Yamaha dealer at the intervals specified in the periodic maintenance and lubrication chart.

Tires

EAUT2141

To maximize the performance, durability, and safe operation of your vehicle, note the following points regarding the specified tires.

Tire air pressure

The tire air pressure should be checked and, if necessary, adjusted before each ride.

EWA10501

WARNING

Operation of this vehicle with improper tire pressure may cause severe injury or death from loss of control.

- **The tire air pressure must be checked and adjusted on cold tires (i.e., when the temperature of the tires equals the ambient temperature).**
- **The tire air pressure must be adjusted in accordance with the riding speed and with the total weight of rider, passenger, cargo,**

PERIODIC MAINTENANCE AND ADJUSTMENT

and accessories approved for this model.

Tire air pressure (measured on cold tires):

Up to 90 kg (198 lb):

Front:

175 kPa (1.75 kgf/cm², 25 psi)

Rear:

175 kPa (1.75 kgf/cm², 25 psi)

90 kg (198 lb) to maximum load:

Front:

175 kPa (1.75 kgf/cm², 25 psi)

Rear:

175 kPa (1.75 kgf/cm², 25 psi)

Maximum load*:

177 kg (390 lb)

* Total weight of rider, passenger, cargo and accessories

EWA10511

WARNING

Never overload your vehicle. Operation of an overloaded vehicle could cause an accident.

Tire inspection

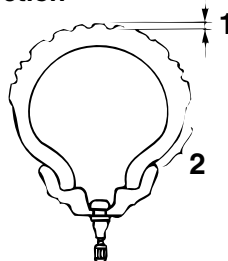

ZALM00*

1. Tire tread depth
2. Tire sidewall

The tires must be checked before each ride. If the center tread depth reaches the specified limit, if the tire has a nail or glass fragments in it, or if the sidewall is cracked, have a Yamaha dealer replace the tire immediately.

Minimum tire tread depth (front and rear):

0.8 mm (0.03 in)

TIP

The tire tread depth limits may differ from country to country. Always comply with the local regulations.

Tire information

This model is equipped with tubeless tires.

After extensive tests, only the tires listed below have been approved for this model by Yamaha Motor Co., Ltd.

Front tire:

Size:

120/90-10 57J

Manufacturer/model:

CHENG SHIN/C-6022

Rear tire:

Size:

120/90-10 57J

Manufacturer/model:

CHENG SHIN/C-6022

EWA10470

WARNING

- Have a Yamaha dealer replace excessively worn tires. Besides

PERIODIC MAINTENANCE AND ADJUSTMENT

being illegal, operating the vehicle with excessively worn tires decreases riding stability and can lead to loss of control.

- The replacement of all wheel and brake related parts, including the tires, should be left to a Yamaha dealer, who has the necessary professional knowledge and experience.

Cast wheels

To maximize the performance, durability, and safe operation of your motorcycle, note the following points regarding the specified wheels.

- The wheel rims should be checked for cracks, bends or warpage before each ride. If any damage is found, have a Yamaha dealer replace the wheel. Do not attempt even the smallest repair to the wheel. A deformed or cracked wheel must be replaced.
- The wheel should be balanced whenever either the tire or wheel has been changed or replaced. An unbalanced wheel can result in poor performance, adverse handling characteristics, and a shortened tire life.
- Ride at moderate speeds after changing a tire since the tire surface must first be “broken in” for it to develop its optimal characteristics.

EAU21960

Adjusting the front and rear brake lever free play

EAU22151

Front

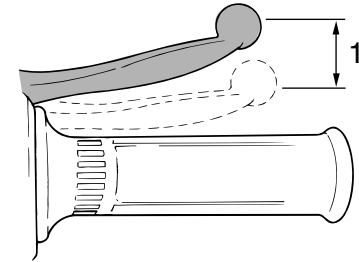

ZALIM001*

1. Front brake lever free play

Rear

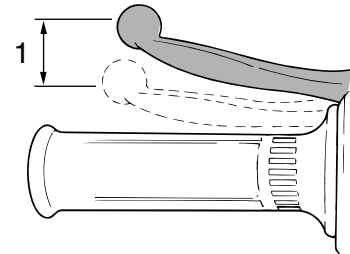

ZALIM001*

1. Rear brake lever free play

PERIODIC MAINTENANCE AND ADJUSTMENT

The front and rear brake lever free play should be measured at the positions as shown.

Front brake lever free play:

10 ~ 20 mm (0.4 ~ 0.8 in)

Rear brake lever free play:

10 ~ 20 mm (0.4 ~ 0.8 in)

Periodically check the front and rear brake lever free play and, if necessary, adjust them as follows.

Front

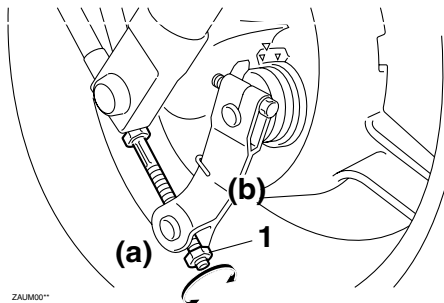

1. Adjusting nut

Rear

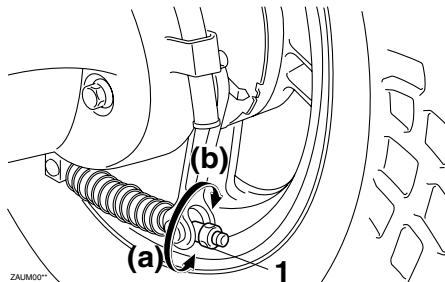

1. Adjusting nut

To increase the brake lever free play, turn the adjusting nut at the brake shoe plate in direction (a). To decrease the brake lever free play, turn the adjusting nut in direction (b).

EWA10650



WARNING

If proper adjustment cannot be obtained as described, have a Yamaha dealer make this adjustment.

EAU22361

Checking the front and rear brake shoes

Front

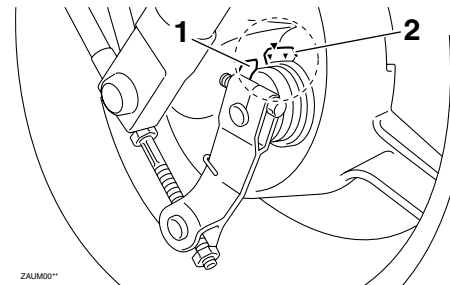

1. Wear indicator
2. Wear limit line

PERIODIC MAINTENANCE AND ADJUSTMENT

Rear

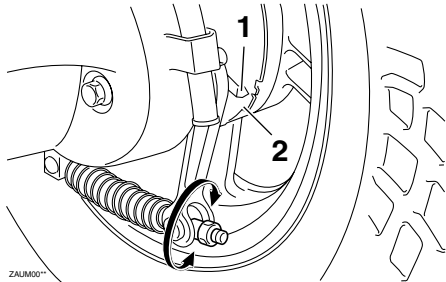

1. Wear indicator
2. Wear limit line

The front and rear brake shoes must be checked for wear at the intervals specified in the periodic maintenance and lubrication chart. Each brake is provided with a wear indicator, which allows you to check the brake shoe wear without having to disassemble the brake. To check the brake shoe wear, check the position of the wear indicator while applying the brake. If a brake shoe has worn to the point that the wear indicator reaches the wear limit line, have a Yamaha dealer replace the brake shoes as a set.

EAU23111

Checking and lubricating the throttle grip and cable

The operation of the throttle grip should be checked before each ride. In addition, the cable should be lubricated at the intervals specified in the periodic maintenance chart.

EAU43631

Lubricating the front and rear brake levers

The pivoting points of the front and rear brake levers must be lubricated at the intervals specified in the periodic maintenance and lubrication chart.

Recommended lubricant:
Lithium-soap-based grease

PERIODIC MAINTENANCE AND ADJUSTMENT

Checking and lubricating the centerstand

EAU23192

The operation of the centerstand should be checked before each ride, and the pivots and metal-to-metal contact surfaces should be lubricated if necessary.

EWA11301

WARNING

If the centerstand does not move up and down smoothly, have a Yamaha dealer check or repair it. Otherwise, the centerstand could contact the ground and distract the operator, resulting in a possible loss of control.

Recommended lubricant:
Lithium-soap-based grease

Checking the front fork

EAU23272

The condition and operation of the front fork must be checked as follows at the intervals specified in the periodic maintenance and lubrication chart.

To check the condition

Check the inner tubes for scratches, damage and excessive oil leakage.

To check the operation

1. Place the vehicle on a level surface and hold it in an upright position. **WARNING! To avoid injury, securely support the vehicle so there is no danger of it falling over.**^[EWA10751]
2. While applying the front brake, push down hard on the handlebars several times to check if the front fork compresses and rebounds smoothly.

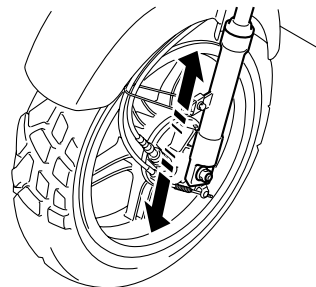

ZAJM00**

ECA10590

NOTICE

If any damage is found or the front fork does not operate smoothly, have a Yamaha dealer check or repair it.

PERIODIC MAINTENANCE AND ADJUSTMENT

EAU45511

Checking the steering

Worn or loose steering bearings may cause danger. Therefore, the operation of the steering must be checked as follows at the intervals specified in the periodic maintenance and lubrication chart.

1. Place the vehicle on the centerstand. **WARNING! To avoid injury, securely support the vehicle so there is no danger of it falling over.**^[EWA10751]
2. Hold the lower ends of the front fork legs and try to move them forward and backward. If any free play can be felt, have a Yamaha dealer check or repair the steering.

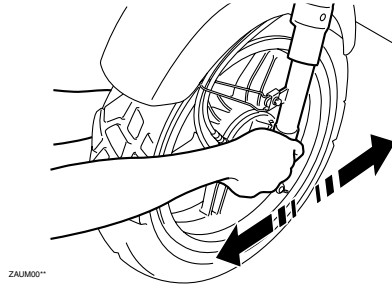

EAU23290

Checking the wheel bearings

The front and rear wheel bearings must be checked at the intervals specified in the periodic maintenance and lubrication chart. If there is play in the wheel hub or if the wheel does not turn smoothly, have a Yamaha dealer check the wheel bearings.

PERIODIC MAINTENANCE AND ADJUSTMENT

EAUT1857

EWA10760

Battery

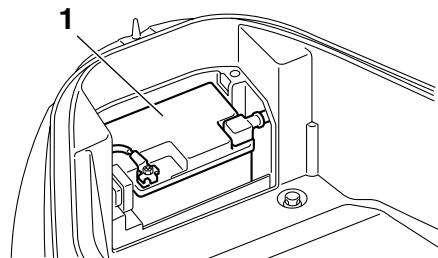

ZAJM001

1. Battery

This model is equipped with a VRLA (Valve Regulated Lead Acid) battery. There is no need to check the electrolyte or to add distilled water. However, the battery lead connections need to be checked and, if necessary, tightened.

TIP

The battery is located behind panel C. (See page 6-6.)

WARNING

- **Electrolyte is poisonous and dangerous since it contains sulfuric acid, which causes severe burns. Avoid any contact with skin, eyes or clothing and always shield your eyes when working near batteries. In case of contact, administer the following FIRST AID.**
 - **EXTERNAL:** Flush with plenty of water.
 - **INTERNAL:** Drink large quantities of water or milk and immediately call a physician.
 - **EYES:** Flush with water for 15 minutes and seek prompt medical attention.
- **Batteries produce explosive hydrogen gas. Therefore, keep sparks, flames, cigarettes, etc., away from the battery and provide sufficient ventilation when charging it in an enclosed space.**
- **KEEP THIS AND ALL BATTERIES**

OUT OF THE REACH OF CHILDREN.

To charge the battery

Have a Yamaha dealer charge the battery as soon as possible if it seems to have discharged. Keep in mind that the battery tends to discharge more quickly if the vehicle is equipped with optional electrical accessories.

ECA16520

NOTICE

To charge a VRLA (Valve Regulated Lead Acid) battery, a special (constant-voltage) battery charger is required. Using a conventional battery charger will damage the battery. If you do not have access to a constant-voltage battery charger, have a Yamaha dealer charge your battery.

To store the battery

1. If the vehicle will not be used for more than one month, remove the battery, fully charge it, and then

PERIODIC MAINTENANCE AND ADJUSTMENT

place it in a cool, dry place. **NOTICE:** When removing the battery, be sure the key is turned to “OFF”, then disconnect the negative lead before disconnecting the positive lead.^[ECA16302]

2. If the battery will be stored for more than two months, check it at least once a month and fully charge it if necessary.
3. Fully charge the battery before installation.
4. Before installation, make sure that the battery leads are properly connected to the battery terminals.^[ECAT1053]

NOTICE

- Always keep the battery charged. Storing a discharged battery can cause permanent battery damage.
- After installing the battery, be sure to turn the main switch from “ON” to “OFF” three times in 3 seconds intervals to initialize the idle speed control system.

Replacing the fuse

EAUT2023

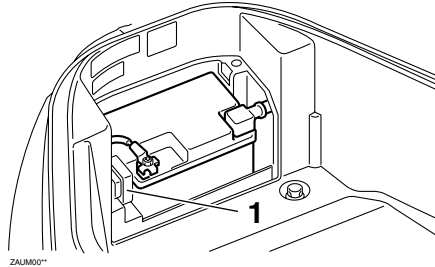

1. Fuse

The fuse holder is located beside the battery. Remove panel C to access the fuse. (See page 6-6.)

If the fuse is blown, replace it as follows.

1. Turn the key to “OFF” and turn off all electrical circuits.
2. Remove the blown fuse, and then install a new fuse of the specified amperage. **WARNING! Do not use a fuse of a higher amperage rating than recommended to avoid causing extensive damage to the**

electrical system and possibly a fire.^[EWA15131]

NOTICE: After removing and installing the main fuse, be sure to turn the main switch from “ON” to “OFF” three times in 3 seconds intervals to initialize the idle speed control system.^[ECAT1062]

Specified fuse:
15 A

3. Turn the key to “ON” and turn on the electrical circuits to check if the devices operate.
4. If the fuse immediately blows again, have a Yamaha dealer check the electrical system.

PERIODIC MAINTENANCE AND ADJUSTMENT

Replacing the headlight bulb

EAU23782

This model is equipped with a quartz bulb headlight. If the headlight bulb burns out, replace it as follows.

ECA10660

NOTICE

Do not touch the glass part of the headlight bulb to keep it free from oil, otherwise the transparency of the glass, the luminosity of the bulb, and the bulb life will be adversely affected. Thoroughly clean off any dirt and fingerprints on the headlight bulb using a cloth moistened with alcohol or thinner.

1. Remove the headlight unit by removing the screws.

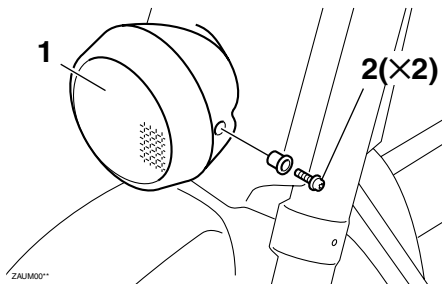

1. Headlight unit
2. Screw

2. Disconnect the headlight coupler, and then remove the bulb cover.

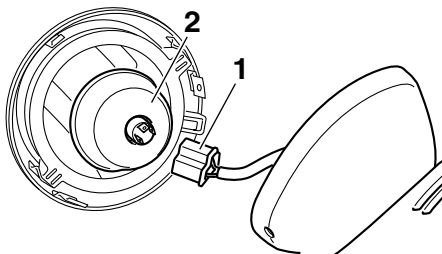

1. Headlight coupler
2. Bulb cover

3. Remove the headlight bulb holder by turning it counterclockwise, and then remove the burnt-out bulb.

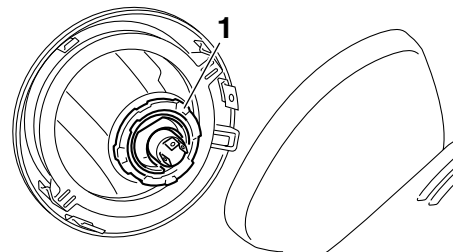

1. Headlight bulb holder

4. Place a new headlight bulb into position, and then secure it with the bulb holder.
5. Install the headlight bulb cover, and then connect the coupler.
6. Install the headlight unit by installing the screws.
7. Have a Yamaha dealer adjust the headlight beam if necessary.

PERIODIC MAINTENANCE AND ADJUSTMENT

Replacing the tail/brake light bulb

EAU24133

1. Remove the tail/brake light lens by removing the screws.

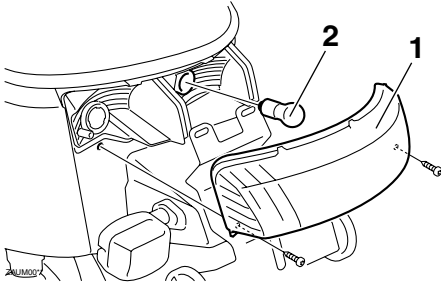

1. Tail/brake light lens
2. Bulb

2. Remove the burnt-out bulb by pushing it in and turning it counterclockwise.
3. Insert a new bulb into the socket, push it in, and then turn it clockwise until it stops.

4. Install the lens by installing the screws. **NOTICE: Do not over-tighten the screws, otherwise the lens may break.**[ECA10681]

Replacing a turn signal light bulb

EAU24204

1. Remove the turn signal light lens by removing the screw.

Front

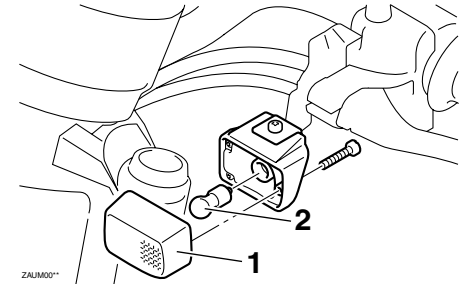

1. Turn signal light lens
2. Bulb

PERIODIC MAINTENANCE AND ADJUSTMENT

Rear

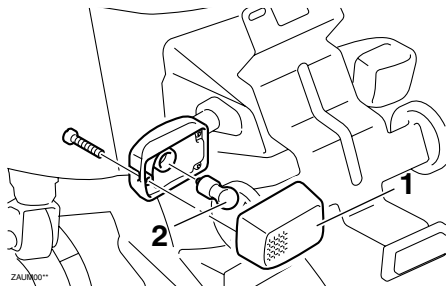

1. Turn signal light lens
2. Bulb

6

2. Remove the burnt-out bulb by pushing it in and turning it counterclockwise.
3. Insert a new bulb into the socket, push it in, and then turn it clockwise until it stops.
4. Install the lens by installing the screw. **NOTICE: Do not over-tighten the screw, otherwise the lens may break.**^[ECA11191]

EAU25881

EWA15141

Troubleshooting

Although Yamaha scooters receive a thorough inspection before shipment from the factory, trouble may occur during operation. Any problem in the fuel, compression, or ignition systems, for example, can cause poor starting and loss of power.

The following troubleshooting charts represent quick and easy procedures for checking these vital systems yourself. However, should your scooter require any repair, take it to a Yamaha dealer, whose skilled technicians have the necessary tools, experience, and know-how to service the scooter properly.

Use only genuine Yamaha replacement parts. Imitation parts may look like Yamaha parts, but they are often inferior, have a shorter service life and can lead to expensive repair bills.

WARNING

When checking the fuel system, do not smoke, and make sure there are no open flames or sparks in the area, including pilot lights from water heaters or furnaces. Gasoline or gasoline vapors can ignite or explode, causing severe injury or property damage.

PERIODIC MAINTENANCE AND ADJUSTMENT

EAU42701

Troubleshooting charts

Starting problems or poor engine performance

1. Fuel

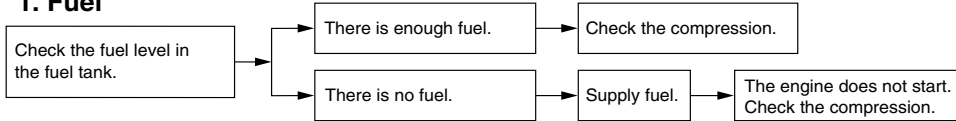

2. Compression

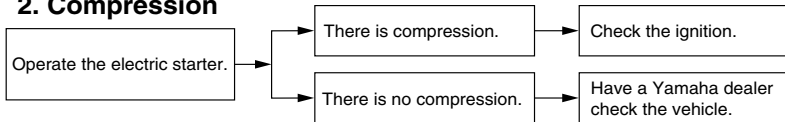

3. Ignition

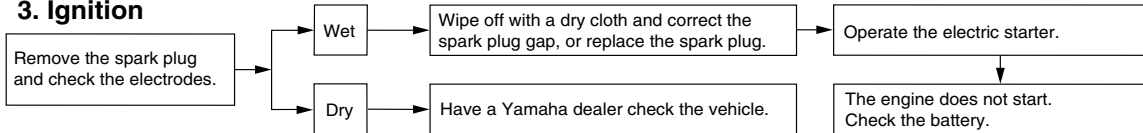

4. Battery

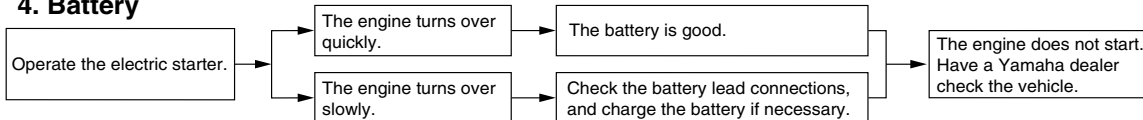

PERIODIC MAINTENANCE AND ADJUSTMENT

Engine overheating

EWAT1040

⚠ WARNING

- Do not remove the radiator cap when the engine and radiator are hot. Scalding hot fluid and steam may be blown out under pressure, which could cause serious injury. Be sure to wait until the engine has cooled.
- Place a thick rag, like a towel, over the radiator cap, and then slowly rotate the cap counterclockwise to the detent to allow any residual pressure to escape. When the hissing sound has stopped, press down on the cap while turning it counterclockwise, and then remove the cap.

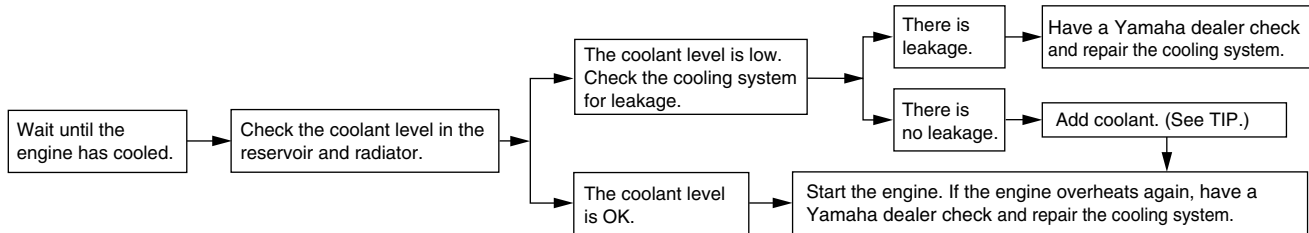

TIP

If coolant is not available, tap water can be temporarily used instead, provided that it is changed to the recommended coolant as soon as possible.

Matte color caution

EAU37833

ECA15192

NOTICE

Some models are equipped with matte colored finished parts. Be sure to consult a Yamaha dealer for advice on what products to use before cleaning the vehicle.

Using a brush, harsh chemical products or cleaning compounds when cleaning these parts will scratch or damage their surface. Wax also should not be applied to any matte colored finished parts.

Care

EAU26093

While the open design of a scooter reveals the attractiveness of the technology, it also makes it more vulnerable. Rust and corrosion can develop even if high-quality components are used. A rusty exhaust pipe may go unnoticed on a car, however, it detracts from the overall appearance of a scooter. Frequent and proper care does not only comply with the terms of the warranty, but it will also keep your scooter looking good, extend its life and optimize its performance.

Before cleaning

1. Cover the muffler outlet with a plastic bag after the engine has cooled down.
2. Make sure that all caps and covers as well as all electrical couplers and connectors, including the spark plug cap, are tightly installed.
3. Remove extremely stubborn dirt, like oil burnt onto the crankcase, with a degreasing agent and a brush, but never apply such prod-

ucts onto seals, gaskets and wheel axles. Always rinse the dirt and degreaser off with water.

Cleaning

ECA10782

NOTICE

- Avoid using strong acidic wheel cleaners, especially on spoked wheels. If such products are used on hard-to-remove dirt, do not leave the cleaner on the affected area any longer than instructed. Also, thoroughly rinse the area off with water, immediately dry it, and then apply a corrosion protection spray.
- Improper cleaning can damage plastic parts (such as cowlings, panels, windshields, headlight lenses, meter lenses, etc.) and the mufflers. Use only a soft, clean cloth or sponge with water to clean plastic. However, if the plastic parts cannot be thoroughly cleaned with water, di-

SCOOTER CARE AND STORAGE

luted mild detergent with water may be used. Be sure to rinse off any detergent residue using plenty of water, as it is harmful to plastic parts.

- Do not use any harsh chemical products on plastic parts. Be sure to avoid using cloths or sponges which have been in contact with strong or abrasive cleaning products, solvent or thinner, fuel (gasoline), rust removers or inhibitors, brake fluid, antifreeze or electrolyte.
- Do not use high-pressure washers or steam-jet cleaners since they cause water seepage and deterioration in the following areas: seals (of wheel and swingarm bearings, fork and brakes), electric components (couplers, connectors, instruments, switches and lights), breather hoses and vents.
- For scooters equipped with a windshield: Do not use strong

cleaners or hard sponges as they will cause dulling or scratching. Some cleaning compounds for plastic may leave scratches on the windshield. Test the product on a small hidden part of the windshield to make sure that it does not leave any marks. If the windshield is scratched, use a quality plastic polishing compound after washing.

After normal use

Remove dirt with warm water, a mild detergent, and a soft, clean sponge, and then rinse thoroughly with clean water. Use a toothbrush or bottlebrush for hard-to-reach areas. Stubborn dirt and insects will come off more easily if the area is covered with a wet cloth for a few minutes before cleaning.

After riding in the rain, near the sea or on salt-sprayed roads

Since sea salt or salt sprayed on the roads during winter are extremely corro-

sive in combination with water, carry out the following steps after each ride in the rain, near the sea or on salt-sprayed roads.

TIP

Salt sprayed on roads in the winter may remain well into spring.

1. Clean the scooter with cold water and a mild detergent after the engine has cooled down. **NOTICE: Do not use warm water since it increases the corrosive action of the salt.**^[ECA10791]
2. Apply a corrosion protection spray on all metal, including chrome- and nickel-plated, surfaces to prevent corrosion.

After cleaning

1. Dry the scooter with a chamois or an absorbing cloth.
2. Use a chrome polish to shine chrome, aluminum and stainless-steel parts, including the exhaust

SCOOTER CARE AND STORAGE

system. (Even the thermally induced discoloring of stainless-steel exhaust systems can be removed through polishing.)

3. To prevent corrosion, it is recommended to apply a corrosion protection spray on all metal, including chrome- and nickel-plated, surfaces.
4. Use spray oil as a universal cleaner to remove any remaining dirt.
5. Touch up minor paint damage caused by stones, etc.
6. Wax all painted surfaces.
7. Let the scooter dry completely before storing or covering it.

EWA10941

WARNING

Contaminants on the brakes or tires can cause loss of control.

- **Make sure that there is no oil or wax on the brakes or tires. If necessary, clean the brake discs and brake linings with a regular brake disc cleaner or acetone, and wash the tires with warm water**

and a mild detergent.

- **Before operating the scooter test its braking performance and cornering behavior.**

ECA10800

NOTICE

- **Apply spray oil and wax sparingly and make sure to wipe off any excess.**
- **Never apply oil or wax to any rubber and plastic parts, but treat them with a suitable care product.**
- **Avoid using abrasive polishing compounds as they will wear away the paint.**

TIP

- Consult a Yamaha dealer for advice on what products to use.
- Washing, rainy weather or humid climates can cause the headlight lens to fog. Turning the headlight on

for a short period of time will help remove the moisture from the lens.

SCOOTER CARE AND STORAGE

Storage

Short-term

Always store your scooter in a cool, dry place and, if necessary, protect it against dust with a porous cover.

EAU36561

ECA10820

NOTICE

- **Storing the scooter in a poorly ventilated room or covering it with a tarp, while it is still wet, will allow water and humidity to seep in and cause rust.**
- **To prevent corrosion, avoid damp cellars, stables (because of the presence of ammonia) and areas where strong chemicals are stored.**

Long-term

Before storing your scooter for several months:

1. Follow all the instructions in the “Care” section of this chapter.
2. Fill up the fuel tank and add fuel

stabilizer (if available) to prevent the fuel tank from rusting and the fuel from deteriorating.

3. Perform the following steps to protect the cylinder, piston rings, etc. from corrosion.
 - a. Remove the spark plug cap and spark plug.
 - b. Pour a teaspoonful of engine oil into the spark plug bore.
 - c. Install the spark plug cap onto the spark plug, and then place the spark plug on the cylinder head so that the electrodes are grounded. (This will limit sparking during the next step.)
 - d. Turn the engine over several times with the starter. (This will coat the cylinder wall with oil.)
 - e. Remove the spark plug cap from the spark plug, and then install the spark plug and the spark plug cap. **WARNING! To prevent damage or injury from sparking, make sure to ground the spark**

plug electrodes while turning the engine over.^[EWA10951]

4. Lubricate all control cables and the pivoting points of all levers and pedals as well as of the sidestand/centerstand.
5. Check and, if necessary, correct the tire air pressure, and then lift the scooter so that both of its wheels are off the ground. Alternatively, turn the wheels a little every month in order to prevent the tires from becoming degraded in one spot.
6. Cover the muffler outlet with a plastic bag to prevent moisture from entering it.
7. Remove the battery and fully charge it. Store it in a cool, dry place and charge it once a month. Do not store the battery in an excessively cold or warm place [less than 0 °C (30 °F) or more than 30 °C (90 °F)]. For more information on storing the battery, see page 6-19.

SCOOTER CARE AND STORAGE

TIP _____
Make any necessary repairs before storing the scooter.

SPECIFICATIONS

Dimensions

Overall length	1915 mm (75.4 in)
Overall width	695 mm (27.4 in)
Overall height	1040 mm (40.9 in)
Seat height	750 mm (29.5 in)
Wheelbase	1280 mm (50.4 in)
Ground clearance	115 mm (4.53 in)
Minimum turning radius	2000 mm (78.7 in)

Weight

With oil and fuel	93.0 kg (205 lb)
-------------------	------------------

Engine

Engine type	Liquid cooled 4-stroke, SOHC
Cylinder arrangement	Forward-inclined single cylinder
Displacement	49.0 cm ³
Bore x stroke	38.0 x 43.6 mm (1.50 x 1.72 in)
Compression ratio	12.00 :1
Starting system	Electric starter and kickstarter
Lubrication system	Wet sump

Engine oil

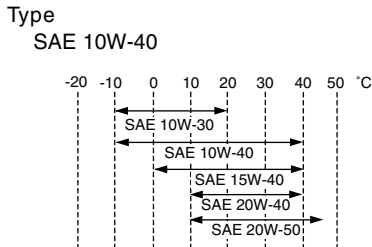

Recommended engine oil grade	API service SG type or higher, JASO standard MA
Periodic oil change	0.78 L (0.82 US qt, 0.69 Imp.qt)

Final transmission oil

Type	SAE 10W-30 type SE motor oil
Quantity	0.10 L (0.11 US qt, 0.09 Imp.qt)

Cooling system

Coolant reservoir capacity (up to the maximum level mark)	0.26 L (0.27 US qt, 0.23 Imp.qt)
Radiator capacity (including all routes)	0.50 L (0.53 US qt, 0.44 Imp.qt)

Air filter

Air filter element	Wet element
--------------------	-------------

Fuel

Recommended fuel	Regular unleaded gasoline only
------------------	--------------------------------

Fuel tank capacity	4.5 L (1.19 US gal, 0.99 Imp.gal)
--------------------	-----------------------------------

Throttle body

Type/quantity	3B31 00(SE AC19-1) / 1
Manufacturer	MIKUNI

Spark plug (s)

Manufacturer/mode	NGK/CR7E
Spark plug gap	0.7-0.8 mm (0.028-0.031 in)

Clutch

Clutch type	Dry, centrifugal automatic
-------------	----------------------------

Transmission

Primary reduction system	Helical gear
Primary reduction ratio	50/13 (3.846)
Secondary reduction system	Helical gear
Secondary reduction ratio	43/12 (3.583)
Transmission type	V-belt automatic
Operation	Centrifugal automatic type

Chassis

Frame type	Steel tube backbone
Caster angle	26.00 degree

Trail
84.0 mm (3.31 in)

Front tire

Type
Tubeless
Size
120/90-10 57J

Manufacturer/model
CHENG SHIN / C-6022

Rear tire

Type
Tubeless
Size
120/90-10 57J

Manufacturer/model
CHENG SHIN / C-6022

Loading

Maximum load
177 kg (390 lb)

Tire air pressure (measured on cold tires)

Front
175 kPa (1.75 kgf/cm², 25 psi, 1.75 bar)

Rear
175 kPa (1.75 kgf/cm², 25 psi, 1.75 bar)

Front wheel

Wheel type
Cast wheel
Rim size
10 x 3.00

Rear wheel

Wheel type
Cast wheel

Rim size
10 x 3.00

Front brake

Type
Drum brake
Operation
Right hand operation

Rear brake

Type
Drum brake
Operation
Left hand operation

Front suspension

Type
Telescopic fork
Spring/shock absorber type
Coil spring
Wheel travel
65.0 mm (2.56 in)

Rear suspension

Type
Unit swing
Spring/shock absorber type
Coil spring
Wheel travel
56.0 mm (2.20 in)

Electrical system

Ignition system
TCI
Charging system
AC magneto

Battery

Model
GTX5L-BS

Voltage, capacity
12 V, 4.0 Ah

Headlight

Bulb type
Halogen bulb

Bulb voltage, wattage x quantity

Headlight
12 V, 35 W/35.0 W x 1
Tail/brake light
12 V, 5.0 W/21.0 W x 1
Front turn signal light
12 V, 10.0 W x 2
Rear turn signal light
12 V, 10.0 W x 2
Meter lighting
12 V, 1.7 W x 1
High beam indicator light
12 V, 1.7 W x 1
Turn signal indicator light
14 V, 3.0 W x 1
Coolant temperature warning light
12 V, 1.7 W x 1
Engine trouble warning light
12 V, 1.7 W x 1

Fuses

Main fuse
15.0 A

CONSUMER INFORMATION

EAU26351

Identification numbers

Record the key identification number, vehicle identification number and model label information in the spaces provided below for assistance when ordering spare parts from a Yamaha dealer or for reference in case the vehicle is stolen.

KEY IDENTIFICATION NUMBER:

VEHICLE IDENTIFICATION NUMBER:

MODEL LABEL INFORMATION:

9

Key identification number

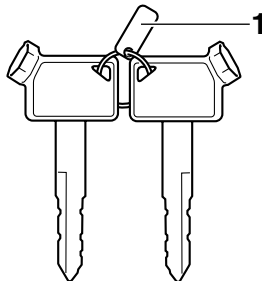

ZAJM00*

1. Key identification number

The key identification number is stamped into the key tag. Record this number in the space provided and use it for reference when ordering a new key.

EAU26381

Vehicle identification number

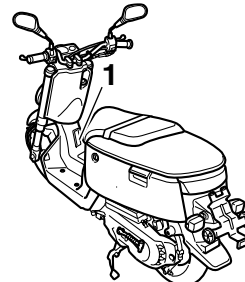

ZAJM00*

1. Vehicle identification number

The vehicle identification number is stamped into the frame.

TIP

The vehicle identification number is used to identify your motorcycle and may be used to register your motorcycle with the licensing authority in your area.

EAUT1440

Model label

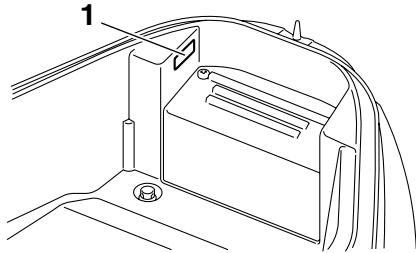

ZAJM001*

1. Model label

The model label is affixed to the inside of the storage compartment. (See page 3-11.) Record the information on this label in the space provided. This information will be needed when ordering spare parts from a Yamaha dealer.

INDEX

A

- Acceleration and deceleration 5-2
- Air filter element, replacing 6-11

B

- Battery 6-19
- Brake lever, front 3-6
- Brake lever, rear 3-7
- Brake levers, lubricating 6-16
- Brake shoes, checking 6-15
- Braking 5-2

C

- Care 7-1
- Catalytic converters 3-9
- Centerstand, checking and lubricating .. 6-17
- Coolant 6-10
- Coolant temperature warning light 3-3

D

- Dimmer switch 3-6

E

- Engine break-in 5-3
- Engine oil 6-7
- Engine trouble warning light 3-4

F

- Final transmission oil 6-9
- Front and rear brake lever free play, adjusting 6-14
- Front fork, checking 6-17
- Fuel 3-8
- Fuel consumption, tips for reducing 5-3
- Fuel gauge 3-5
- Fuel tank cap 3-7
- Fuse, replacing 6-20

H

- Handlebar switches 3-5
- Headlight bulb, replacing 6-21
- Helmet holder 3-10
- High beam indicator light 3-3
- Horn switch 3-6

I

- Identification numbers 9-1
- Indicator and warning lights 3-3

K

- Key identification number 9-1
- Keyhole cover 3-2
- Kickstarter 3-10

L

- Luggage hook 3-12

M

- Main switch/steering lock 3-1
- Matte color, caution 7-1
- Model label 9-2

P

- Panels, removing and installing 6-5
- Parking 5-4
- Part locations 2-1
- Periodic maintenance and lubrication chart 6-2
- Pre-operation check list 4-2

S

- Safe-riding points 1-5
- Safety information 1-1
- Seat 3-10
- Spark plug, checking 6-6
- Specifications 8-1

- Speedometer unit 3-4
- Start switch 3-6
- Starting off 5-2
- Starting the engine 5-1
- Steering, checking 6-18
- Storage 7-4
- Storage compartment 3-11

T

- Tail/brake light bulb, replacing 6-22
- Throttle cable free play, checking 6-12
- Throttle grip and cable, checking and lubricating 6-16
- Tires 6-12
- Troubleshooting 6-23
- Troubleshooting charts 6-24
- Turn signal indicator light 3-3
- Turn signal light bulb, replacing 6-22
- Turn signal switch 3-6

V

- Valve clearance 6-12
- Vehicle identification number 9-1

W

- Wheel bearings, checking 6-18
- Wheels 6-14





PRINTED IN TAIWAN
2008.09-0.8x1 
(E)