

SERVICE MANUAL

中华战马修护手册



PREFACE

- This shop manual describes the technical feature and servicing procedures for the SANYANG XS125-K.
- All information, illustrations, directions and specifications included in this publication are base on SANYANG XS125-K.
- SANYANG reserves the right to make changes at any time without notice and without incurring any obligation whatever.





**SANYANG INDUSTRY CO.,LTD.
SERVICE DIVISION**

CONTENTS

GENERAL INFORMATION.....	1
INSPECTION/ADJUSTMENT	2
LUBRICATION SYSTEM.....	3
ENGINE REMOVAL/INSTALLATION	4
CYLINDER HEAD/VALVE	5
CYLINDER/PISTON.....	6
CLUTCH/OIL PUMP/GEAR SHIFT.....	7
A.C. GENERATOR	8
CRANK SHAFT/CRANK CASE/TRANSMISSION.....	9
CARBURETOR.....	10
HEADLIGHT/STEERING/FRONT WHEEL/FRONT FORK	11
REAR WHEEL/REAR SUSPENSION.....	12
BATTERY/CHARGING SYSTEM	13
IGNITION SYSTEM.....	14
SWITCHES/HORN.....	15
WIRING DIAGRAM	16

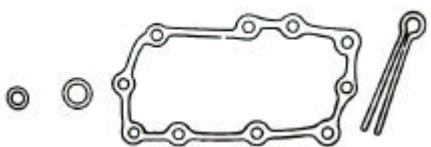
SERVICE RULES.....1-1	TORQUE VALUES1-3
SPECIFICATIONS1-2	TROUBLE SHOOTING1-4

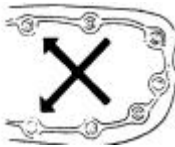
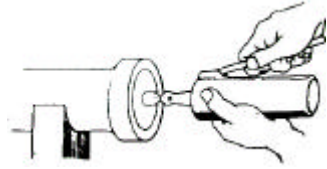
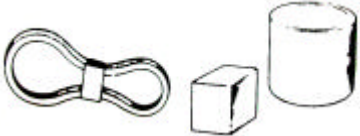
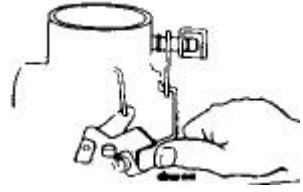
SERVICE RULES:

<p>(1)Use new packings, gaskets,O-rings and cotter pins space and clips whenever reassembling.</p> 	<p>(5)Clean all removed parts in or with solvent, and lubricate their sliding surfaces upon disassembly.</p> 
<p>(2)When tightening bolts or nuts, begin on center or larger diameter bolts and tighten them in criss-cross pattern in two or more steps if necessary.</p> 	<p>(6)Coat or fill parts with specified grease where specified.</p> 
<p>(3)Use genuine SANYANG parts and lubricants or those equivalent. When parts are to be reused, they must be inspected carefully to make sure they are not damaged or deteriorated and in good usable condition.</p> 	<p>(7)Upon assembling, check every possible part for proper installation and movement or operation.</p> 
<p>(4)Use special tool when use of such a tool is specified.</p> 	<p>(8)Work safely and give your work your undivided attention. Exchange signals as frequently as possible when a work involves two or more workers. Do not run the engine unless the shop or working area is well ventilated.</p> 

Symbol Marks:



:Apply engine oil.



:Apply grease.

NOTE: Things must be noticed.

CAUTION: Things that could cause damage to the engine parts.

WARNING: Things that could cause damage to the person or partner.

1.GENERAL INFORMATION



SPECIFICATIONS

	ITEM		XS125-K
DIMENSIONS	Overall length		2040mm
	Overall width		750mm
	Overall height		1100mm
	Wheel base		1280mm
	Ground clearance		150mm
	Dry weight		130kg
FRAME	Type		Single pipe
	Front suspension and travel		Telescope 165mm
	Rear suspension and travel		Swing arm 63mm
	Front tire size and tire pressure		2.75-18 2.25Kg/C m ²
	Rear tire size and tire pressure		90/90-18 2.50Kg/C m ²
	Front brake		Disk type
	Rear brake		Drum type
	Fuel capacity		14.5 liter
	Fuel reserve capacity		2.0 liter
	Caster angle		26 °
	Front fork oil capacity		160c.c
ENGINE	Type		Air cooled 4 stroke engine
	Cylinder arrangement		Single cylinder 15~ include from vertical
	Bore & stroke		56.5 x49.5mm
	Displacement		124.1c.c.
	Compression ratio		9.0:1
	Oil capacity		0.80 ~0.95liter (0.9 liter for change)
	Intake valve	opens	5° BTDC
		closes	35 ° ABDC
	Exhaust valve	opens	30° BBDC
		closes	5 ° ATDC
	Valve clearance	IN.	0.10mm
		EX.	0.15mm
Idle speed		1400 ± 100 rpm	
DRIVE TRAIN	Clutch		Wet multi-plate type
	Transmission		5-speed international
	Primary reduction ratio		4.05
	Gear ratio	I	2.769
		II	1.722
		III	1.318
		IV	1.1250
		V	0.962
Final reduction ratio		2.53	
Gearshift pattern		1 N 2 3 4 5	
ELECTRICAL	Ignition system		C.D.I. unit
	Ignition timing	"F" mark	BTDC 15° ± 20° /1500rpm
		Full advance	BTDC 29.5° ± 2° /4000rpm
	Starting system		Electrical motor and kickstarter
	Alternator		A.C. generator
	Battery capacity		12N7A-3A(8AH)
	Fuse		15A
	Spark plug		D7RC
Spark plug gap		0.6~0.7mm	

ENGINE

TIGHTEN LOCATION	QTY	THREAD DIA(mm)	TORQUE(kgf. cm)
Starting clutch outer bolt socket	3	8	100~150
Cylinder stud bolt	10	6	80~120
Shift drum stopper hex bolt	1	6	80~120
Gear shift cam hex bolt	1	6	80~120
Cylinder stud bolt	4	8	180~220
Cylinder head cap nut	4	8	280~300
Driven gear hex bolt	2	6	100~150
Chain adjuster	2	6	80~120
Oil filter screen cover	1	10	150~300
Starter motor bolt	2	6	80~120
Oil pump HEX bolt	2	6	70~110
Primary drive gear nut	1	16	400~500
Cylinder head bolt	1	8	280~320
Cylinder head nut	4	8	280~320
Fly wheel bolt	1	10	400~500
Cylinder head cover	4	6	80~120
Reduction gear cover bolt	3	6	80~120
L. Crank case cover bolt	8	6	80~120
R. Crank case cover	11	6	80~120
A.C.G.pluse bolt	2	4	40~50
A.C.G. flange bolt	3	5	40~70

FRAME

TIGHTEN LOCATION	QTY	THREAD DIA(mm)	TORQUE(kgf. cm)
Front wheel axle nut	1	14	600~800
Rear wheel axle nut	1	14	1000~1200
Rear fork pivot nut	1	14	800~1000
Engine upper hanger nut	3	10	400~550
Engine front hanger nut	4	10	450~550
Handle pipe upper holder bolt	4	8	180~ 250
Steering stem nut	1	22	600~900
Front fork nut	1	22	400~500
Rear shock absorber	4	10	300~400
Rear brake torque link	1	8	150~200
Front fork top bridge	2	8	400~550
Front fork bottom bridge	2	12	400~500
Final drive sprocket	4	8	270~330
Seat bolt	2	8	200~250
Drive sprocket bolt	2	6	100~140

STANDARD TORQUE

TYPE	TORQUE(kgf.cm)	TYPE	TORQUE(kgf.cm)
5 mm bolt, nut	45~60	5 mm bolt	35~50
6 mm bolt, nut	80~120	6 mm bolt	70~110
8 mm bolt, nut	180~250	6 mm flange bolt, nut	100~140
10 mm bolt, nut	300~400	8 mm flange bolt, nut	240~300
12 mm bolt, nut	500~600	10 mm flange bolt, nut	350~450

Torque specifications listed below for respective locations.

TROUBLE SHOOTING

A. HARD START OR CANNOT START

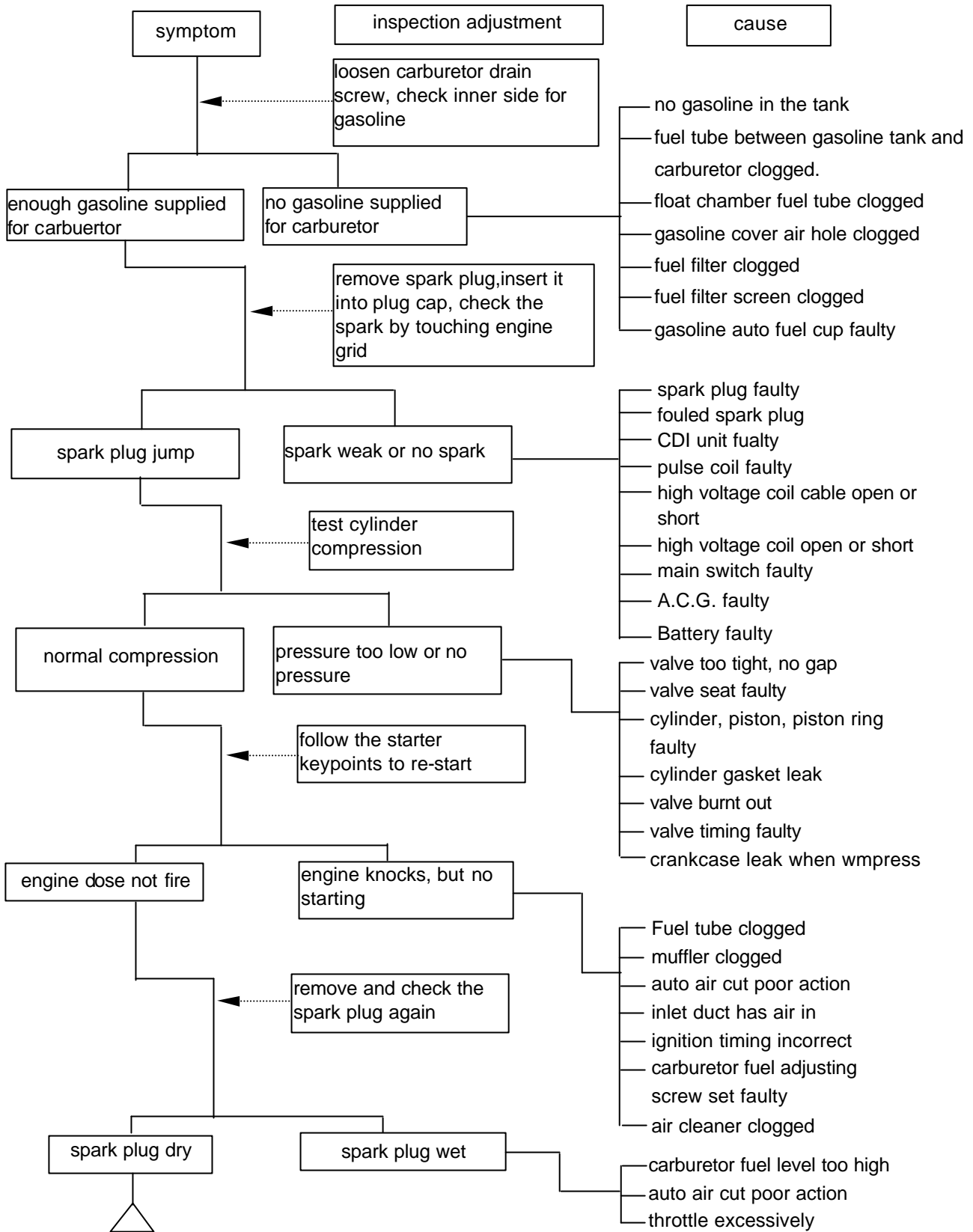

start engine with choke closed

B. ROTATION ROUGH (LACKS POWER)

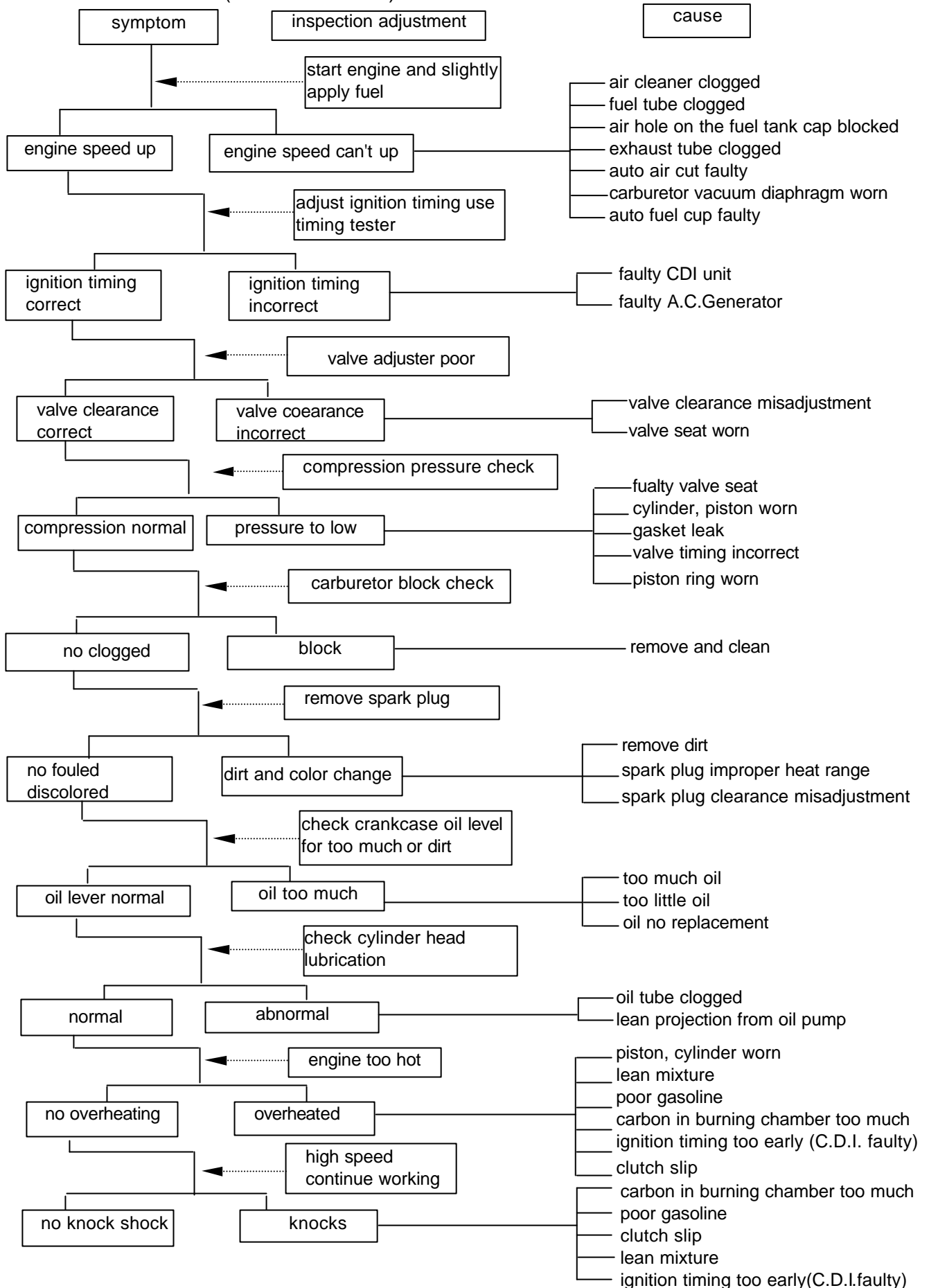

C. ROTATION ROUGH (ESPECIALLY IN THE LOW SPEED AND IDLE SPEED)

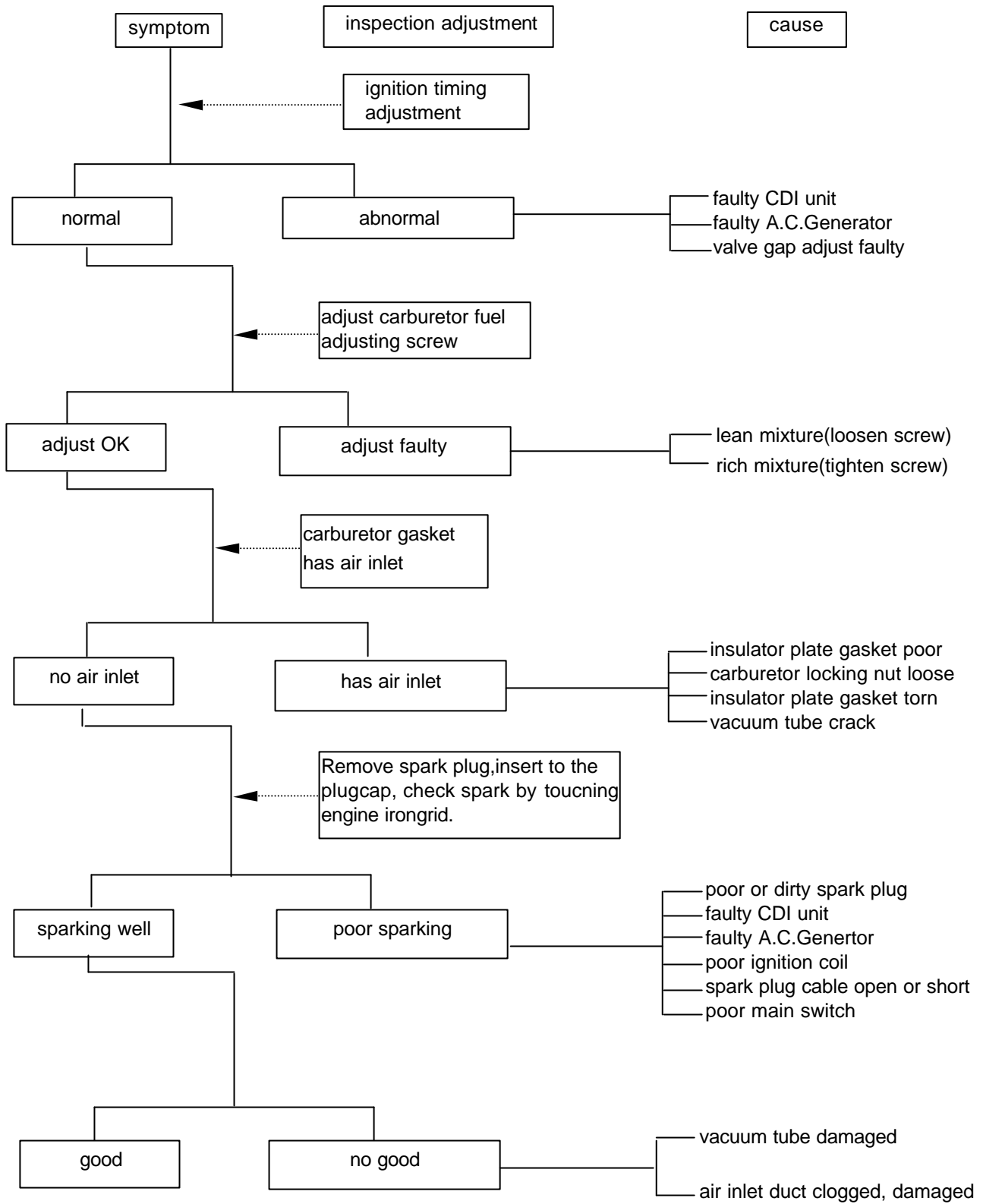

D. ROTATION ROUGH (HIGH SPEED)

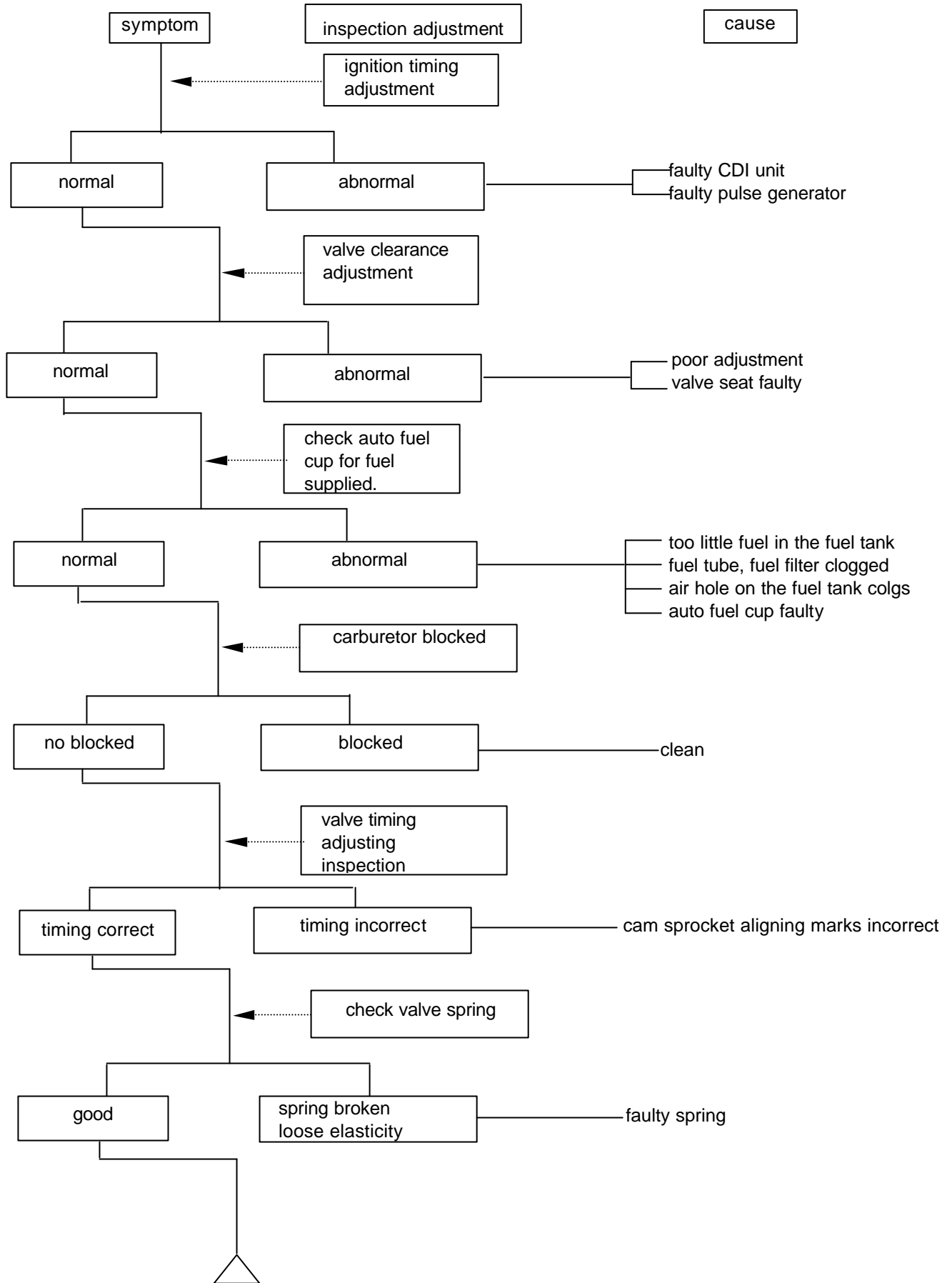

E. POOR CHARGE (BATTERY OVER DISCHARGE OR OVER CHARGE)

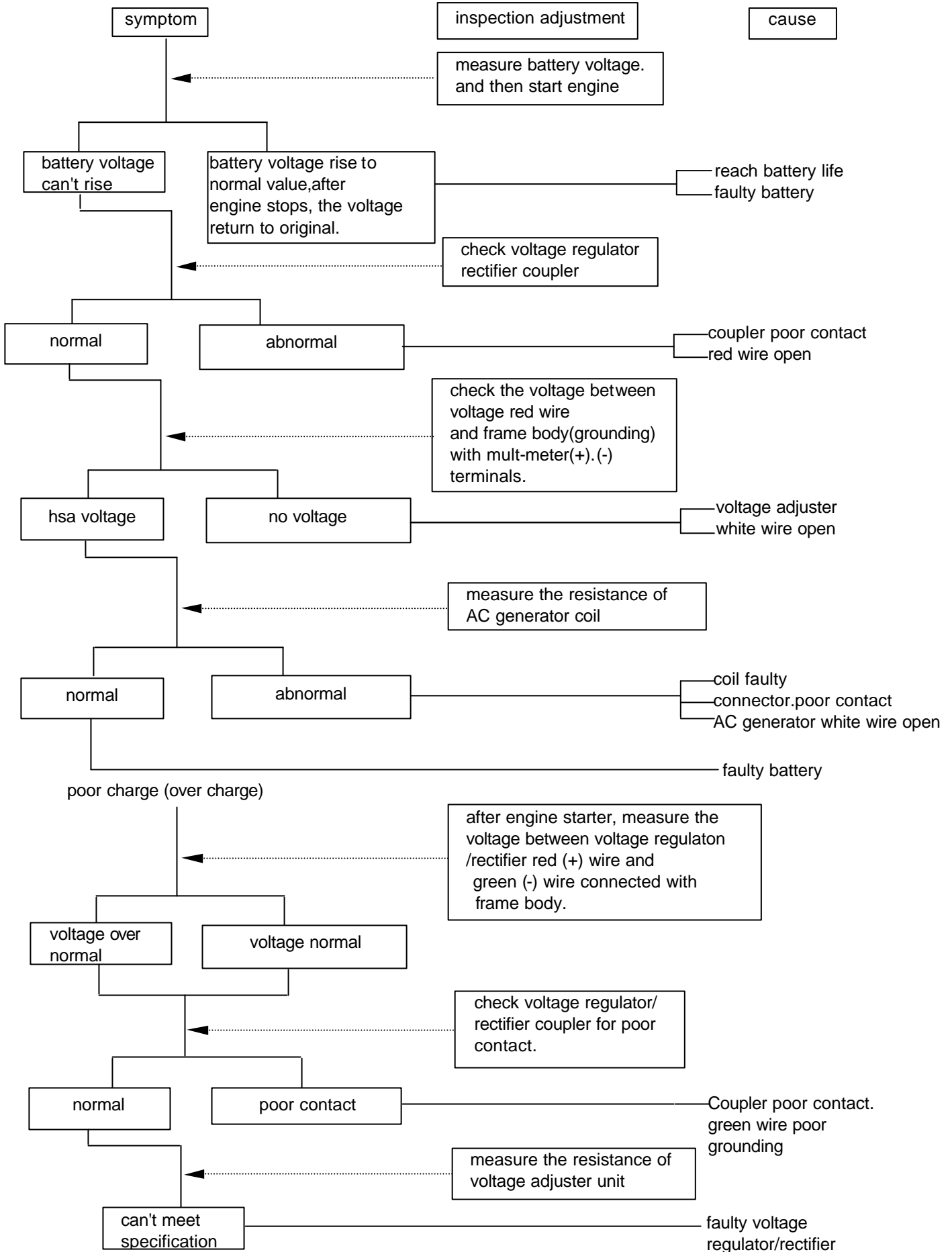

F.SPARK PLUG NO SPARK

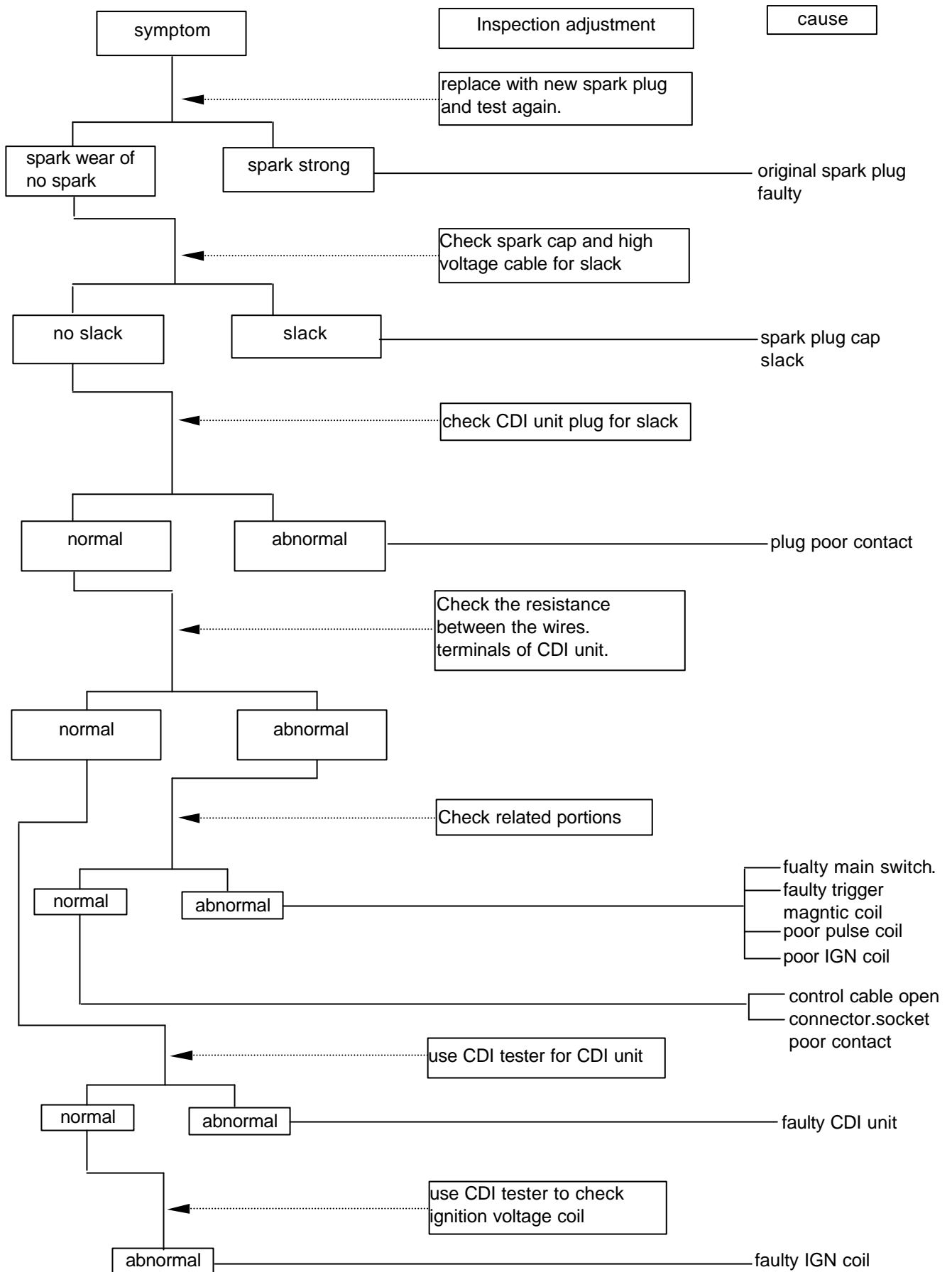

ENGINE	FRAME
MAINTENANCE SCHEDULE2-2	AIR CLEANER..... 2-12
SERVICE INFORMATION.....2-3	CLUTCH ADJUSTMENT 2-12
ENGINE OIL/OIL FILTER.....2-4	BRAKE ADJUSTMENT..... 2-13
SPARK PLUG2-5	DRIVE CHAIN ADJUSTMENT 2-14
COMPRESSION TEST2-6	WHEELS/RIM 2-15
VALVE CLEARANCE2-7	SUSPENSION 2-16
IGNITION TIMING2-8	STEERING 2-17
CAM CHAIN TENSION ADJUSTMENT ..2-9	BATTERY 2-17
THROTTLE GRIP ADJUSTMENT2-10	HEAD LIGHT AIM..... 2-18
IDLING SPEED ADJUSTMENT2-11	STOPLIGHT SWITCH..... 2-18

2.INSPECTION/ADJUSTMENT



MAINTENANCE SCHEDULE

Item	Check Items	Maintenance kilometer	300KM	Every 1000KM	Every 3000KM	Every 6000KM	Every 12000KM
		Maintenance Interval	NEW	1 Month	3 Months	6 Months	1 Year
1	Air cleaner		I	C			R
2	Gasoline filter		I			C	R
3	Oil filter		C	Replacement for every 5000KM R			
4	Oil filter screen		C	Cleaning for every 5000km C			
5	Engine Oil		R	Replacement for every 5000KM R			
6	Wheels tires		I	I			
7	Battery		I	I			
8	Brake and operation free play		I	I			
9	Steering stem bearing					I	
10	FR./RR. Cushion		I		I		
11	Screws/nuts		I	I			
12	Spark plug		I		R		
13	Clutch		I		I		
14	Frame of lubrication					L	
15	Exhaust muffler		I	I			
16	Carburetor		I	I			
17	Ignition timing		I	I			
18	Emission		I	I			
19	Idle speed		I	I			
20	Gasoline system		I		I		
21	Throttle cable		I		I		
22	Engine bolt torque		I		I		
23	Deposit of exhaust outlet						I
24	Cylinder head/cylinder Piston exhaust system deposit				I		
25	Cam chain		I		I		
26	Valve clearance		I	I			
27	Light/electrical appliance/Meter		I	I			
28	Side stand & Spring		I			I	

The table is referred to the driving distance about 1000km per month

I-inspection, cleaning, adjustment or replacement (if necessary)R-replacement Gleaning L-lubrication

REMARK: Ridden in unusually dusty areas, require more frequently air filter element cleaning.

SERVICE INFORMATION SPECIFICATLON

ENGINE

Oil capacity	1.1 ~ 1.5 liter
Spark plug gap	A6RTC
Spark plug gap	0.6-0.7mm
Valve clearance IN	0.08mm
EX	0.10mm
Cylinder compression	12.5kg/c m ² ±2kg/c m ²

FRAME

Clutch lever free play	10-20mm
Drive chain slack	10-20mm
Front brake lever free play	10-20mm
Rear brake pedal free play	20-30mm
Throttle grip free play	2-6mm

SPECIAL TOOL

Valve clearance adjuster

TORQUE VALVES

Right crankcase cover	80-120 kgf . cm
Front fork top bridge bolt	100-140 kgf . cm
Front fork bottom bridge bolt	200-250 kgf . cm
Rear wheel axle nut	400-550 kgf . cm
Rear shock absorber nut	300-400 kgf . cm
Rear fork pivot bolt	350-450 kgf . cm

OIL/OIL FILTER OIL LEVEL CHECK

Start and warm up the engine for few minutes,then stop the engine.

Check the oil level with oil level gauge after a few minutes.

If the oil level is near the lower mark,fill the crankcase to the upper level mark with the recommended grade oil.



OIL REPLACEMENT

NOTE:

Drain the engine oil while the engine is warm.

Remove the oil filter screen cover, and drain the engine oil.

NOTE :

Make sure that the oil filter screen cover O-ring is in good condition.

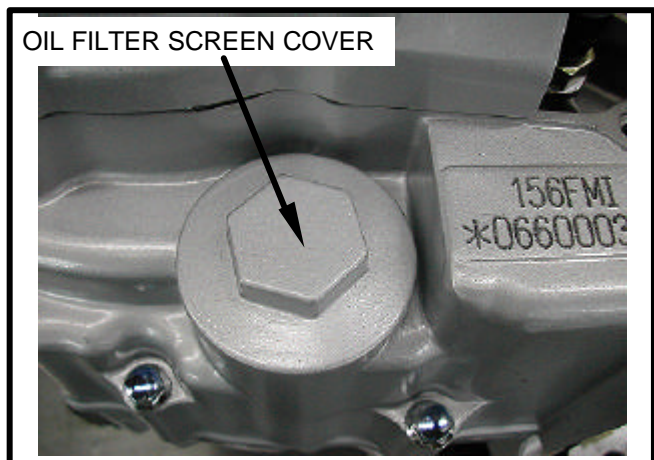

Fill the crankcase up to the upper level mark on the oil level gauge with the recommended oil:15W-40 API:SH/CD

OIL FILTER SCREEN CLEANING

Remove the oil filter cap, oil filter screen and drain the engine oil.

Operate the kick starter several times to drain residual oil completely.

Clean the oil filter screen with compressed air.

Install the oil filter screen, spring and screen cap.

Fill the crankcase with the recommended oil.

OIL CAPACITY:0.9L

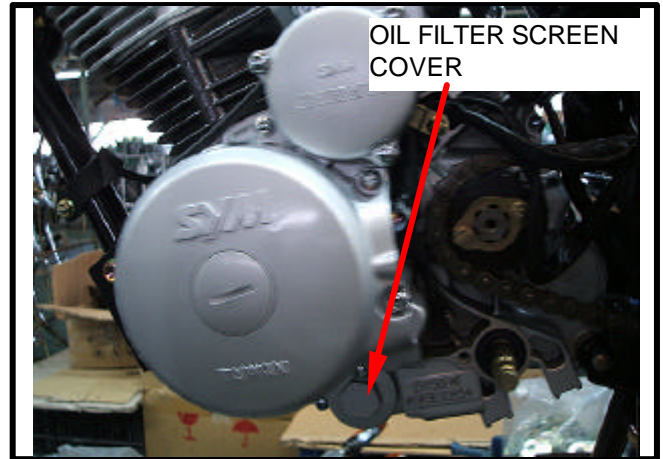

SPARK PLUG

Disconnect the spark plug cap and remove the spark plug .

Visually inspect the spark plug electrodes for wear.

The center electrode should have square edges and side electrode should have a constant thickness.

Discard the spark plug if there is apparent wear or if the insulator is cracked and/or chipped .If the spark plug deposits can be removed by sandblasting or wire brushing,the spark plug can be reused.

Inspect the gap with a feeler gauge and adjust by bending the side electrode.

Standard gap:0.6-0.7mm

NOTE:

To install turn finger tight then tighten with a spark plug wrench.

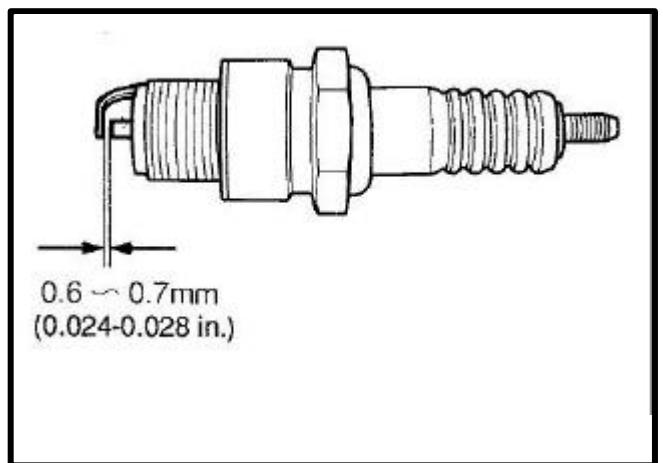

COMPRESSION TEST

Warm up the engine.

Stop the engine .Remove spark plug .Insert the compression gauge.

Push in the choke lever .Open the throttle grip fully.

Electrical start engine several times.

NOTE:

- Watch for compression leaking at the gauge connection.
- Crank the engine until the gauge reading stops rising .The maximum reading is usually reached in several times.

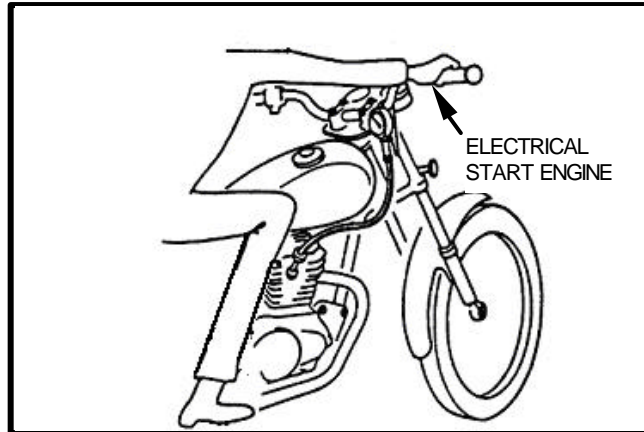

Compression:9.5kg/c m²±1kg/c m²

Low compression can be caused by:

- Improper calve adjustment.
- Valve leakage .
- Blown cylinder head gasket.
- Worn piston rings or cylinder.
- Worn piston.

High compression can be caused by:

- Carbon deposits in combustion chamber or on piston head.

VALVE CLEARANCE

NOTE:

Inspect and adjust the valve clearance while the engine is cold.

Remove the timing inspection hole cap and crankshaft hole cap.

Rotate the generator rotor counterclockwise and align the "T" mark on the generator rotor with the index mark in the left crankcase

(piston must be at T.D.C.of the compression stroke).

Inspect the intake and exhaust valve clearance by inserting a feeler gauge between the adjusting screw and valve stem, valve clearance:

Intake: 0.05mm

Exhaust: 0.10mm

Adjust by loosening the lock nut and turning the adjusting screw until there is a slight drag in the feeler gauge.

NOTE:

Inspect the valve clearance again after tightened the lock nut.

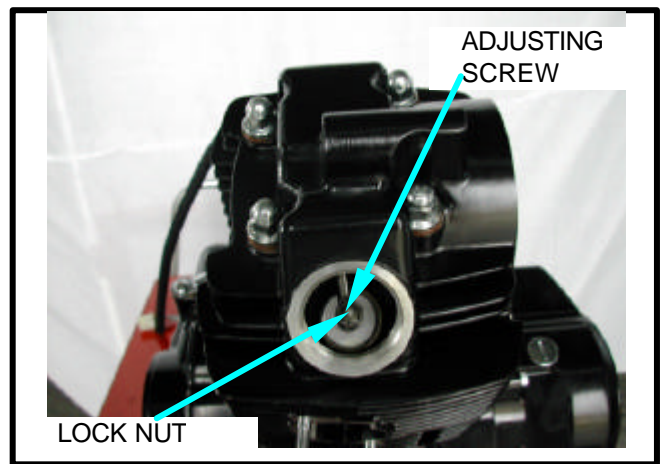
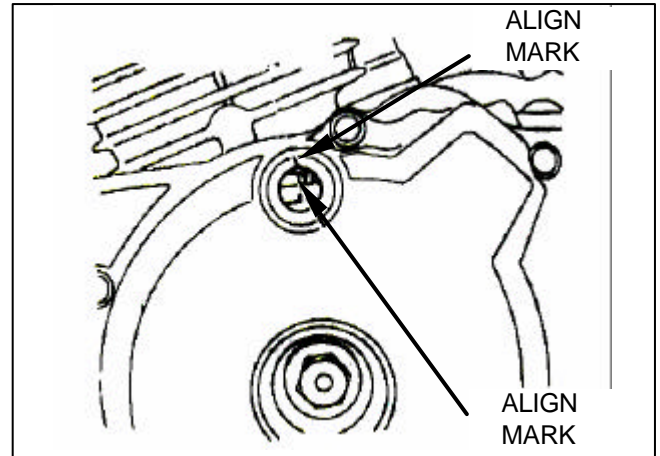

Install the valve adjuster caps and generator cap.
NOTE:

Check the O-ring for damage and spread oil before installing the caps.

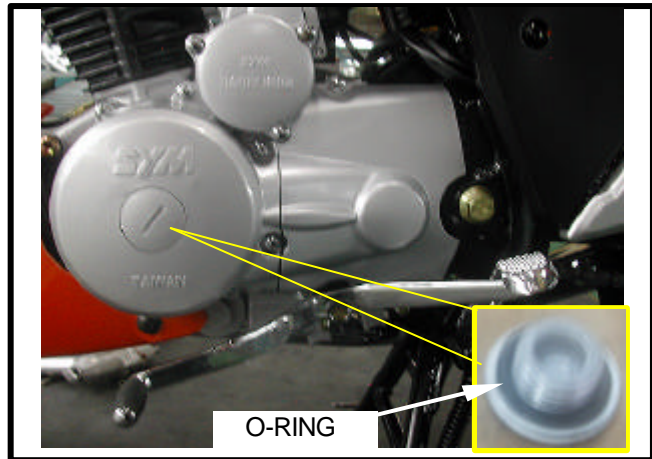

IGNITION TIMING

The C.D.I.ignition timing is not adjustable.
If the ignition timing is not correct ,check the C.D.I.unit and A.C.generator and replace any faulty parts.

Use the standard tester to check the ignition timing.
Spark plug inspection and adjustment.
Replace the coil if there is no sparks at plug.

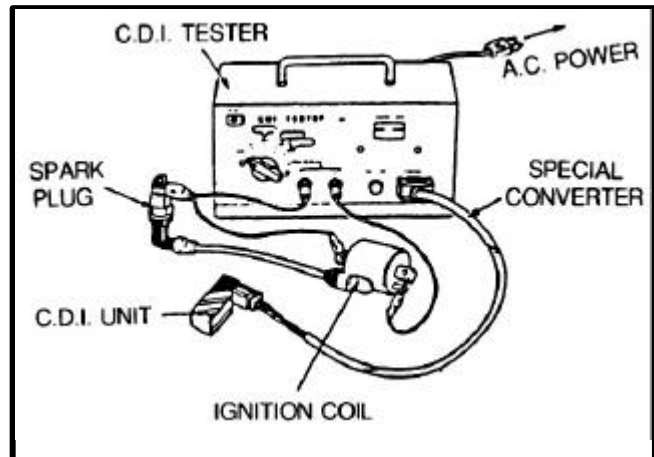

IGNITION TIMING INSPECTION

Remove the generator cover and check the ignition timing with a timing light.

Timing is correct if the index mark aligns with the "F" mark within $\pm 3^\circ$ at 1500rpm.

Ignition timing :10 ° BTDC/1500rpm.

Ignition coil continuity test :

Check the resistance of the primary coil and secondary coil.

1.Primary coil	0.31±0.03
2.Secondary coil	4.0±0.4k

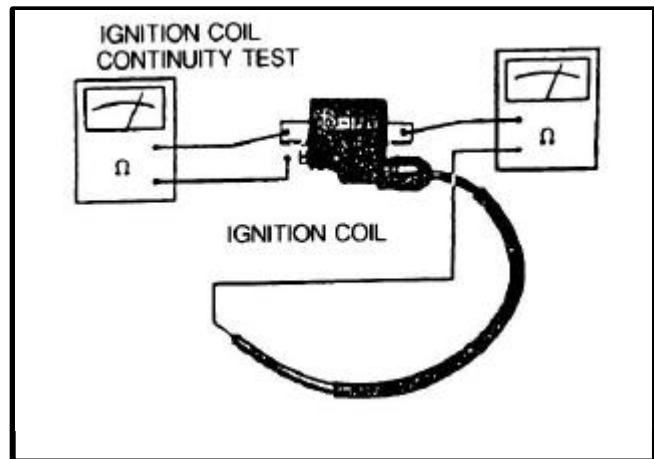

Inspect the C.D.I unit with C.D.I tester.
Replace the faulty C.D.I unit.

SWITCH	C.D.I. normal	C.D.I faulty
1. OFF	no sparks	-----
2. P	no sparks	-----
3. EXT	no sparks	sparks
4. ONI	sparks	no sparks
5. ONZ	sparks	no sparks

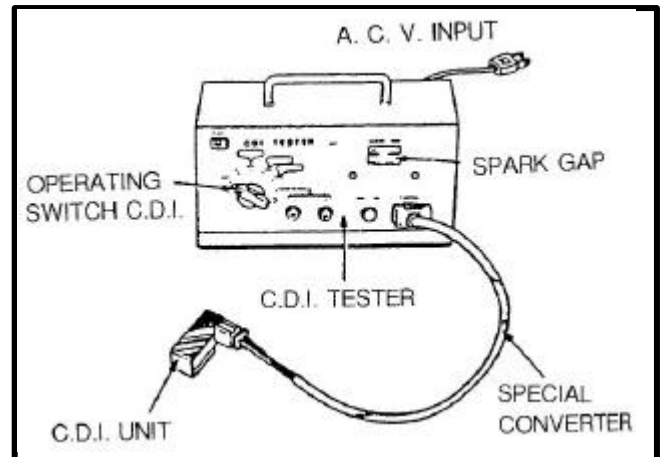

CAM CHAIN TENSIONER ADJUSTER

The cam chain tension is kept by the tensioner push rod that is compressed by the spring.

CAUTION:

If remove any parts that is related with the cam chain ,remove the cam chain tensioner adjuster first.

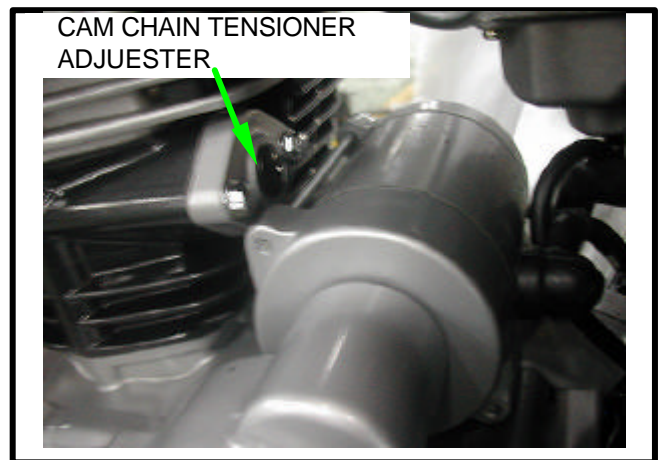

CARBURETOR THROTTLE GRIP FREE PLAY

Check throttle grip free play.
Free play:2-6mm

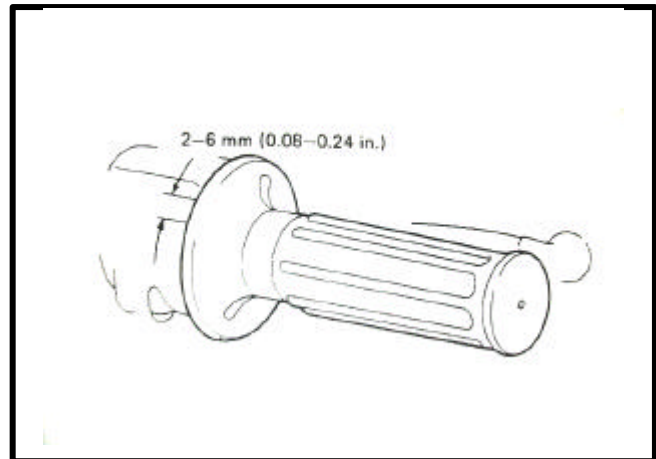

THROTTLE GRIP ADJUSTMENT

Loosen the lock nut and turn the adjuster to adjust.

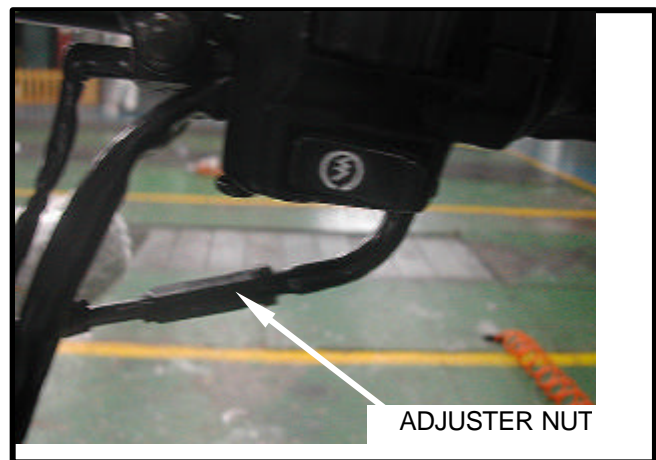

IDLING SPEED ADJUSTMENT

Warm up the engine.

Turn the stop screw to obtain the idling speed of 1100rpm.

Turn the air screw to the maximum speed,then turn the stop screw to obtain the specified idling speed.

Idling speed:1500 ± 100 rpm.

NOTE:

Turn the air screw clockwise for making fuel –air mixture lean.

Turn counterclockwise for rich.

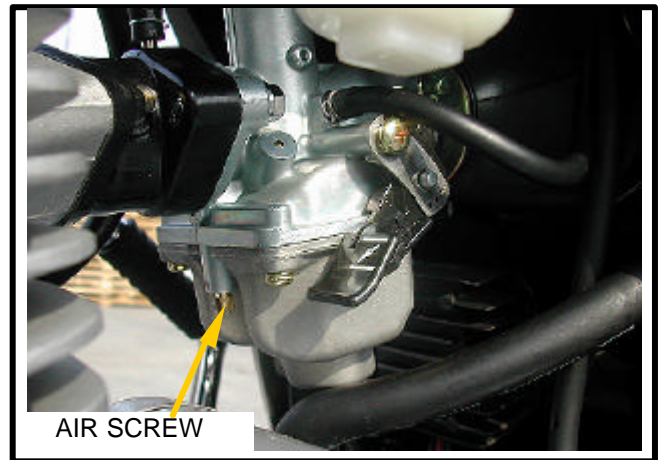
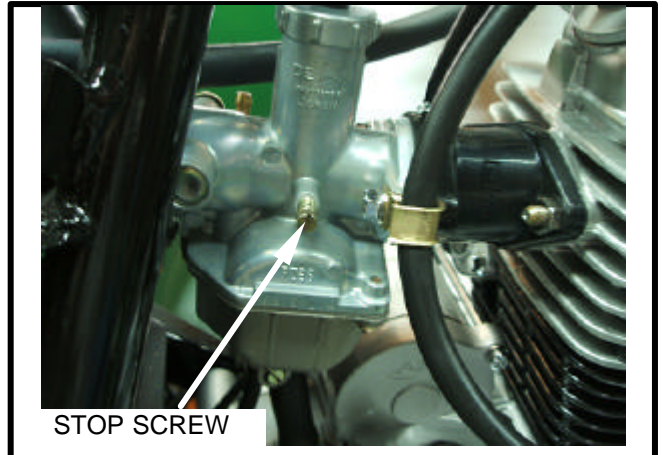

AIR CLEANER

Remove the left side cover.
Remove the air cleaner cover.
Remove the air cleaner element.

NOTE:

Clean the cleaner element periodically.(Refer to maintenance schedule.)

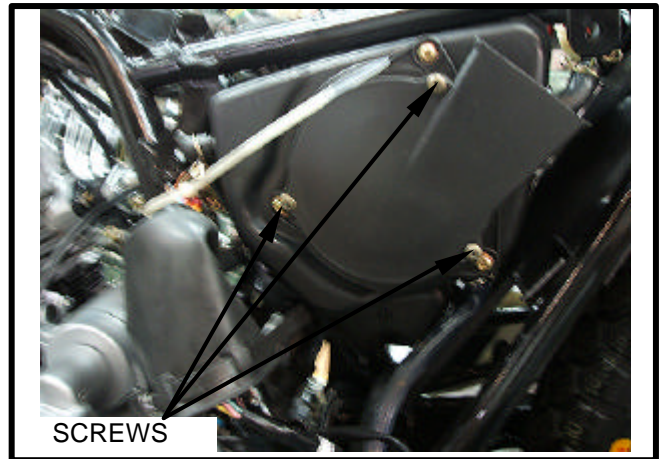

Assemble air cleaner element in reverse order of disassemble.

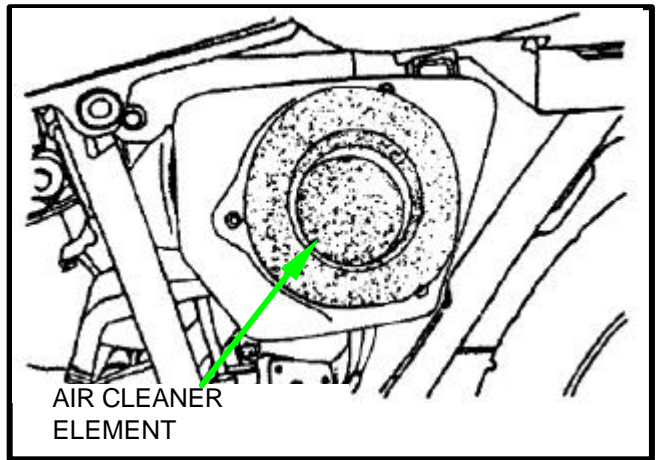

CLUTCH ADJUSTMENT

CLUTCH LEVER FREE PLAY

Measure the clutch free play at the tip of the clutch lever.

Free play :10-20mm

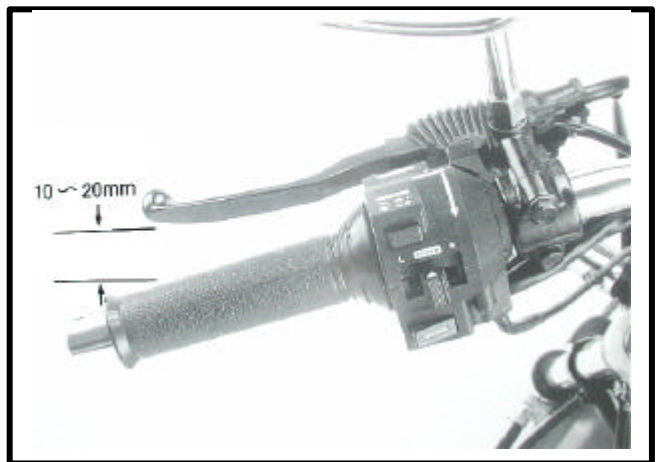

FREE PLAY ADJUSTMENT

Loosen the lock nut and turn the adjuster.
Turn the adjuster ,clockwise for decreasing the free play ,counterclockwise for increasing the free play.

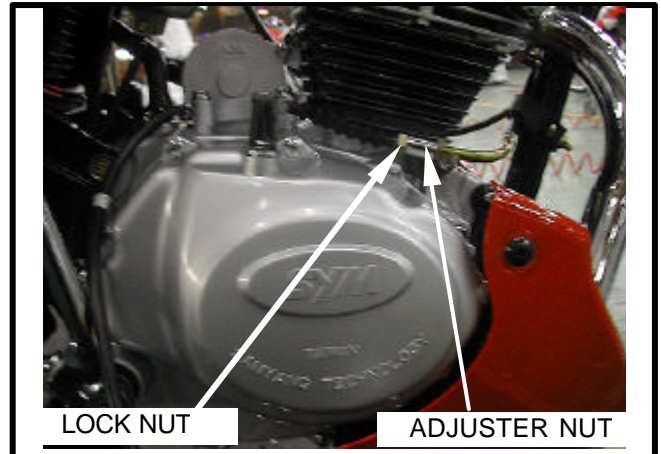

BRAKE ADJUSTMENT

FRONT BRAKE LEVER FREE PLAY

Measure the brake free play at the tip of the brake lever.

Free play:10-20mm

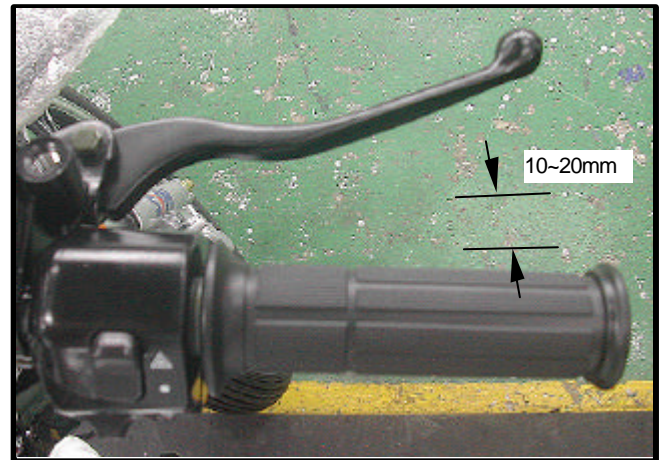

BRAKE PAD WEAR INSPECTION

Check for brake pad wear by operating the brake lever.
Check the brake pads for wear by looking through the slot indicated by the arrow cast on the caliper assembly.

Replace the brake pads if the wear line on the pads reaches the edge of the brake disc.



REAR BRAKE PEDAL FREE PLAY

Measure the brake pedal free play before the brake start to engage.

Free play :20-30mm

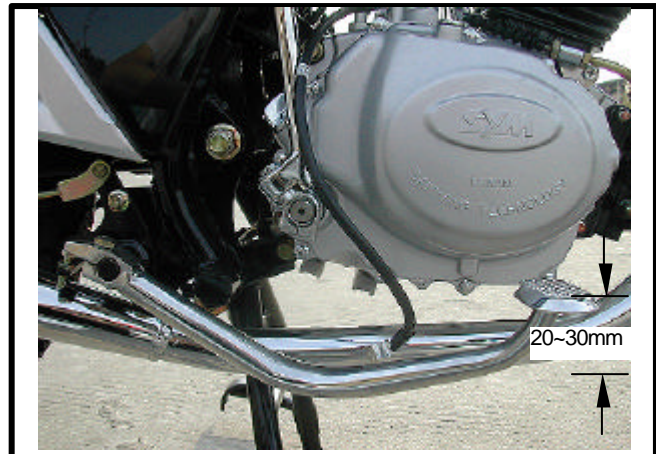

REAR BRAKE PEDAL ADJUSTMENT

Turn the brake adjuster nut clockwise to decrease the free play and counterclockwise to increase the play.

CAUTION:

The adjuster nuts indentation should seat against the brake arm pin properly.

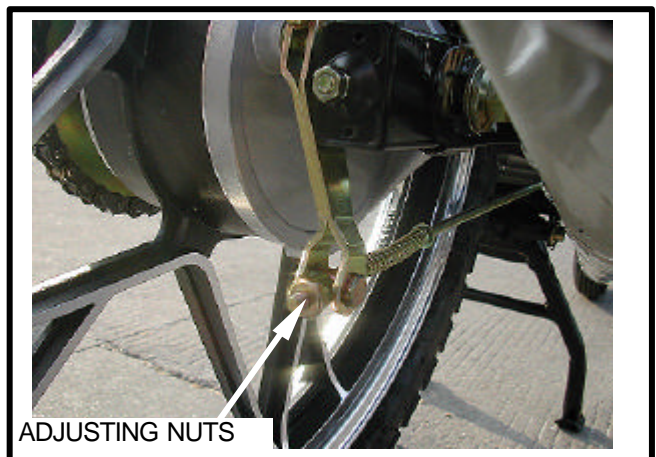

DRIVE CHAIN ADJUSTMENT

Place the motorcycle on its main stand and shift the transmission into neutral.

Remove chain cap and check the drive chain slack by moving up and down with the fingers.

Chain slack:10-20mm

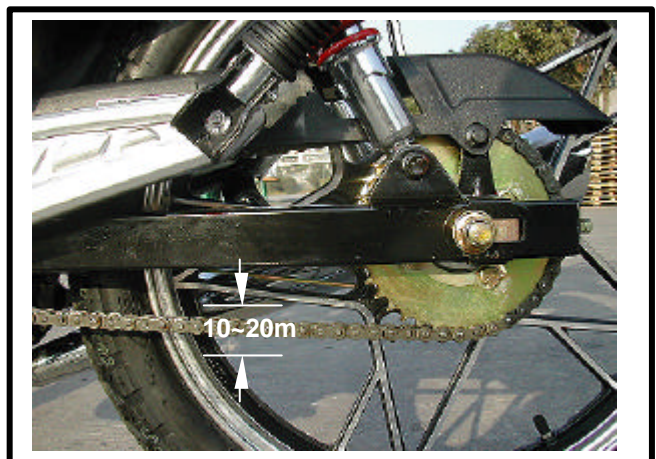

2.INSPECTION/ADJUSTMENT



Loose the rear wheel axle nut for adjusting.
Turn the adjusting nuts on both adjusters as necessary.

CAUTION:

Tighten the axle nut.

TORQUE:1000-1200 kgf · cm

Recheck the drive chain slack and free wheel rotation.
Lubricate the drive chain with chain lubricant.

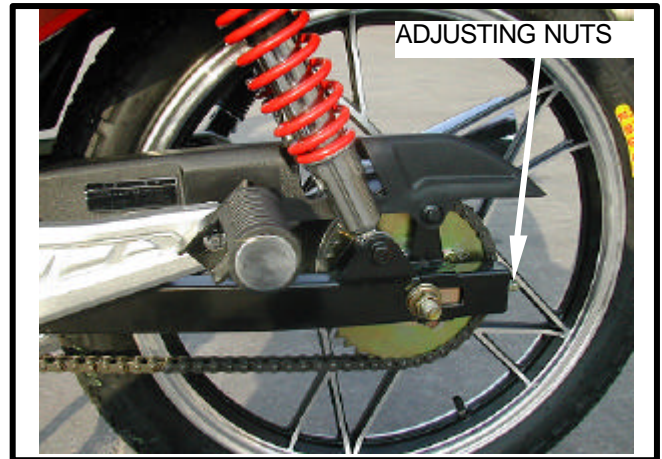

WHEEL/RIM

Stand the motorcycle,check the tires for cuts,imbedded nails,or other sharp objects.
Check the tire pressure.

Cold tire	One rider	Front	2.25 kg/c m ²
		Rear	2.50 kg/c m ²
	Two riders pressure	Front	2.50 kg/c m ²
		Rear	2.50 kg/c m ²
Max.load		120kg	
Tire size		Front	2.75-18
		Rear	90/90-15
Min. depth of tread		Front	1.5mm
		Rear	2.0mm

SUSPENSION

FRONT SUSPENSION

Check the action of the front forks by compressing them several times with the front brake applied .
If there are abnormal noises or rattles ,check all the fasteners and tighten them to the specified torque.

TORQUE:

Front fork top bridge bolt :100-140 kgf . cm

Frint fork bottom bridge bolt :240-300 kgf . cm

Axle nut:600-800 kgf . cm



REAR SUSPENSION

Check for abnormal noises and leaks by compressing the rear suspension several times.

Check the rear suspension nut for loosening

Torque:300-400 kgf . cm

Move the rear wheel side ways with force to see if the swing arm bushings are worn.

Rear fork torque:800-1000 kgf . cm



STEERING

Raise the front wheel off the ground and check that the handlebar rotates freely.If the handlebar moves unevenly ,binds or has vertical movement,adjust the steering head nut.

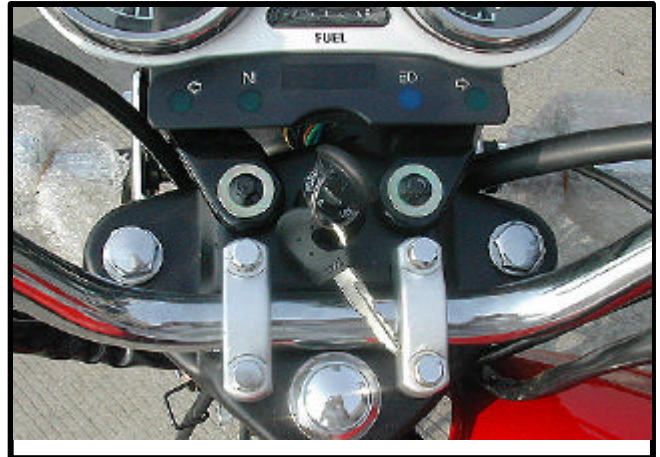

BATTERY

Inspect the battery fluid level ,if the fluid level nears the lower level mark,fill with distilled water to the upper level mark .

Clean the battery terminals with warm water.

Check the specific gravity of the battery electrolyte.(13-3)

NOTE

:

Do not overfill. Add only distilled water.
Tap water will shorten the service life of the battery.

WARNING:

Keep the electrolyte away from eyes ,skin and clothes. If touched it ,wash them with clean water quickly.



HEADLIGHT AIM

Adjust vertically by turning headlight up and down with the headlight bolts loosening.
Fasten the bolts after adjustment.

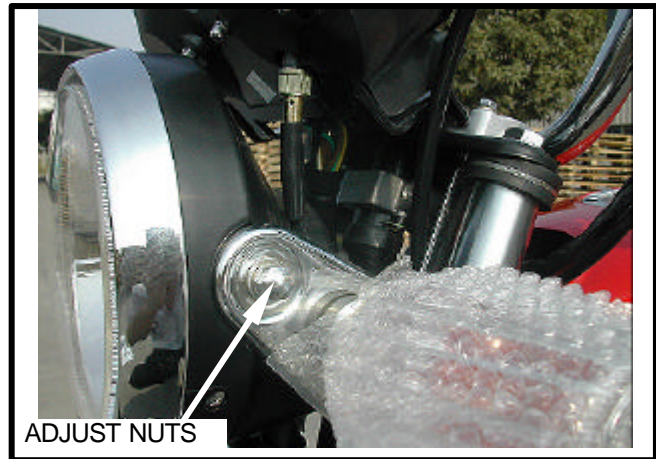

STOPLIGHT SWITCH

The stoplight should come on when the brake pedal is depressed 20mm from the standard pedal position.If the action is abnormal, adjust by turning the stoplight switch adjusting nut.

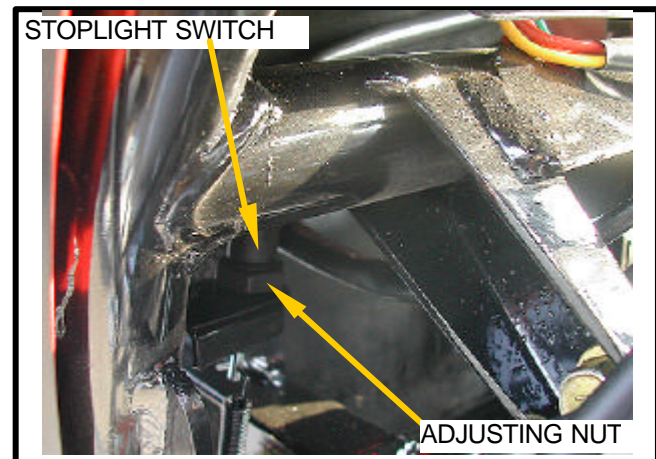

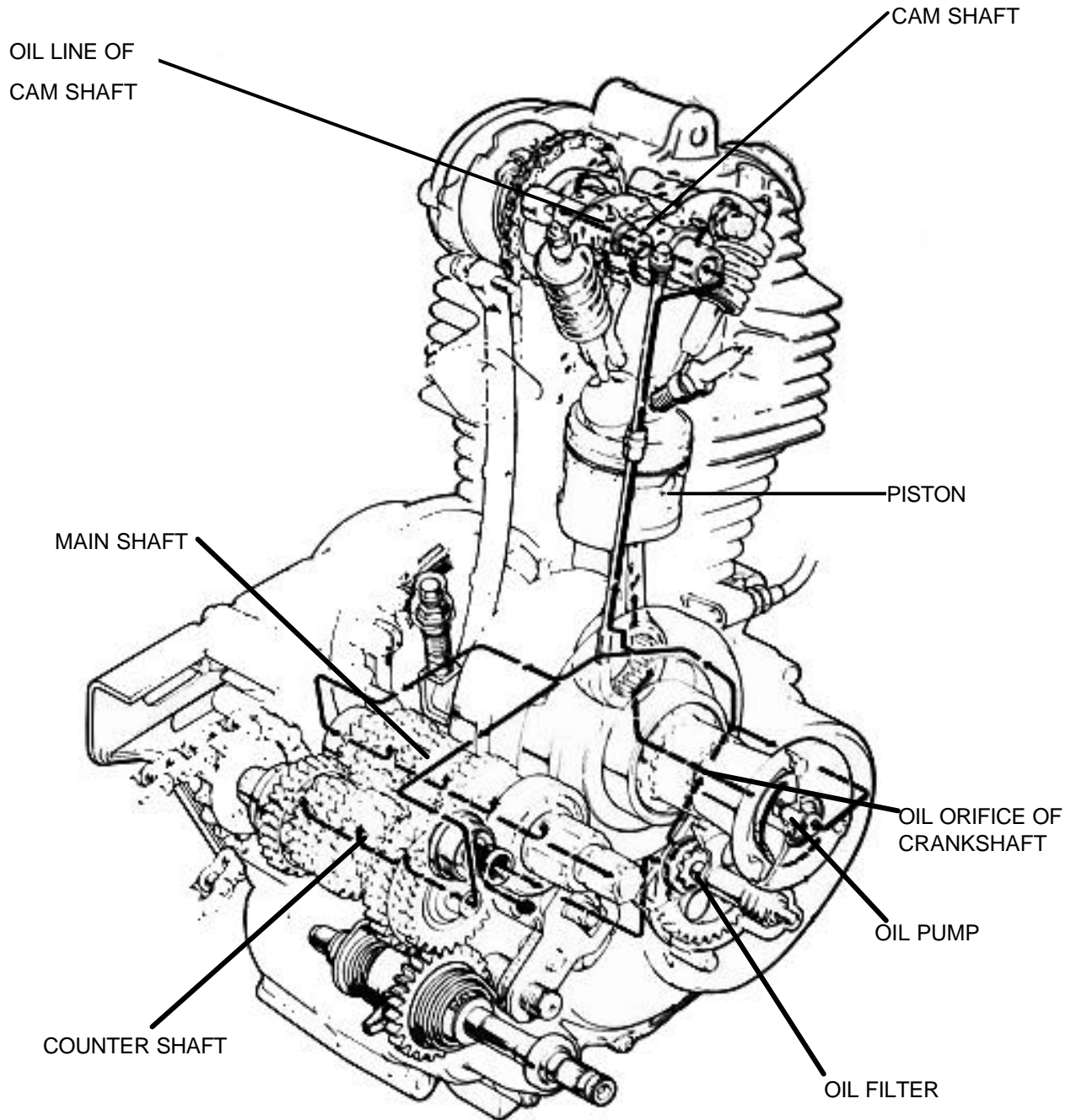

TROUBLE SHOOTING.....3-1	SERVICE INFORMATION..... 3-1
--------------------------	------------------------------

TROUBLE SHOOTING

OIL LEVEL TOO LOW

- 1. Natural consumption
- 2. Oil leaks
- 3. Worn piston rings

OIL CONTAMINATION

- 1. Oil not changed often enough
- 2. Faulty cylinder head gasket

OIL PRESSURE TOO LOW

- 1. Oil filter clogged
- 2. Oil pump damaged

OIL PRESSURE TOO HIGH

- 1. Oil filter or line clogged
- 2. Oil not recommended

NO OIL PRESSURE

- 1. Oil level too low
- 2. Oil pump damaged

SERVICE INFORMATION

NOTICE:

Inspection and service of oil pump can be serviced with the engine installed on the frame.

Oil pump service --- 7-9

Oil filter cleaning --- 2-4 ~ 2-5

SPECIFICATIONS

Oil capacity	0.85~0.90 liter
Oil recommended	SAE 15W-40 API:SH/CD
Oil pump delivery	3.5 liter above / min. / 4600rpm

SERVICE INFORMATION.....4-1	ENGINE INSTALLATION..... 4-4
ENGINE REMOVAL.....4-2	

SERVICE INFORMATION

GENERAL INSTRUCTIONS

The following parts can be serviced with the engine installed on the frame:

- Generator
- Clutch
- Oil pump
- Cam shaft / Rocker arm
- Shift spindle
- Cam chain tensioner
- Kick starter arm

The following parts must be serviced with the engine removed off the frame:

- Cylinder head
- Cylinder
- Piston
- Crankshaft
- Transmission
- Kick starter shift

During removal and installation, jack or adjustable support is required to maneuver the engine.

TORQUE VALUES

Engine hanger 10mm bolt / nut	450-550 kgf · cm
Drain bolt	300-500 kgf · cm
Gearshift pedal bolt	80-120 kgf · cm
Kick starter pedal bolt	80-120 kgf · cm

ENGINE REMOVAL

Drain the engine oil.
Turn the fuel cock to "OFF" and disconnect the fuel tubes and all connect tubes.
Remove the right and left side covers.



Remove the gear change pedal and left crank case rear cover.

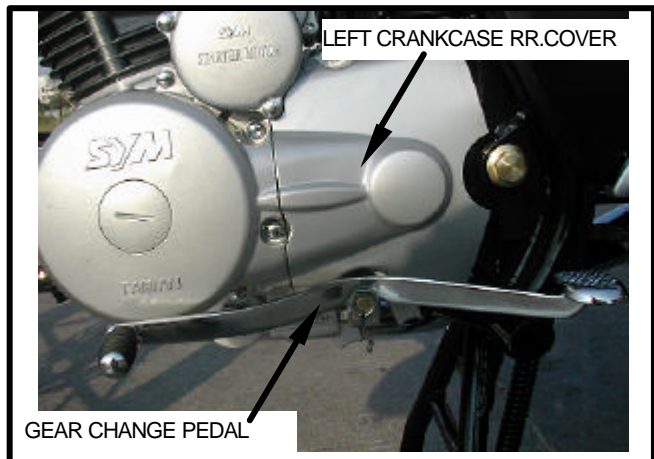

Disconnect the A.C. generator wire of the connector and remove the generator wire.
Remove the wire clamp screw and clamp.

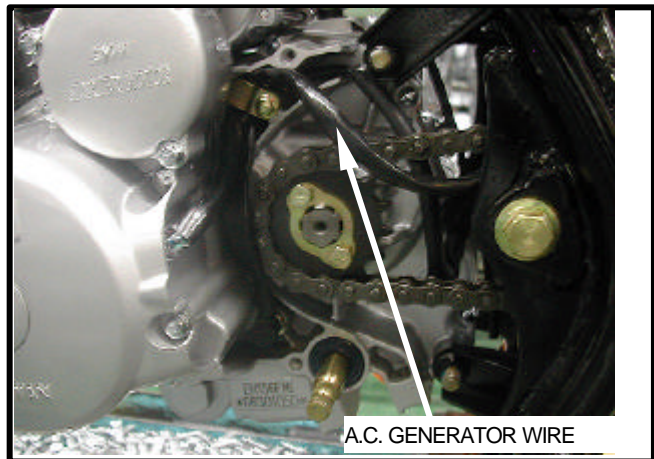

4.ENGINE REMOVAL/INSTALLATION

Remove the clutch cable.
Remove the spark plug cap.
Remove the muffler.

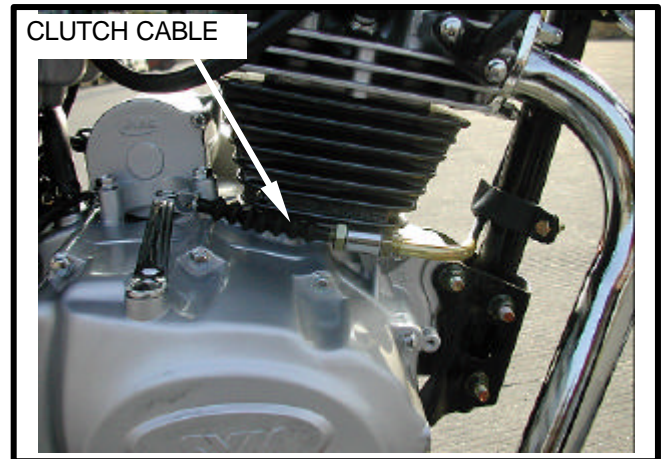

Loosen carburetor clip.
Separate the carburetor pipe and the cylinder head by removing the attaching bolts.
Remove the crankcase breather tube.

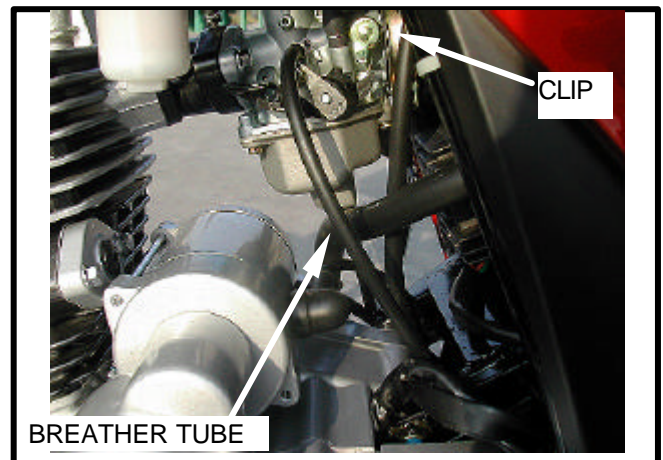

Loosen the rear wheel axle nut.
Loosen the drive chain adjusting nut and push the rear wheel forward.
Remove the drive chain clip, and remove the drive chain.

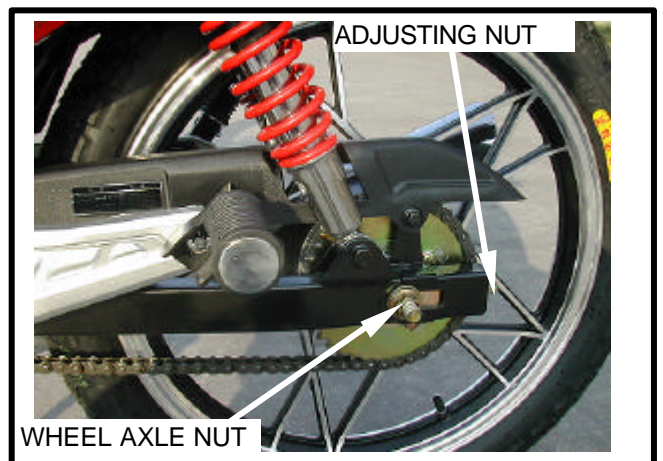

4.ENGINE REMOVAL/INSTALLATION



Remove the front engine hanger bolt.

NOTE:

Places jack or padded block under the engine before removing the front engine hanger.

Disconnect the starter motor wire.

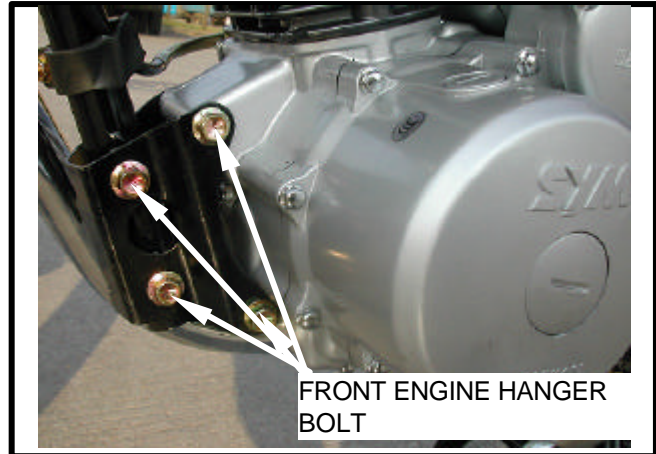

Remove the 10mm bolts of the rear engine hanger.

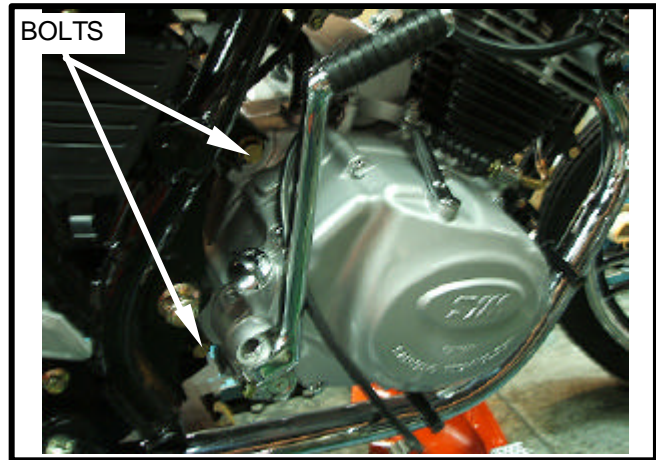

Remove the engine.

NOTE:

Prevent damage to wire harnesses and cables during operation.

ENGINE INSTALLATION

Follow the reverse procedure of removal to install the engine.

Notice the following items during installation:

- Route all wire harnesses and cables properly.
- Adjust the throttle grip free play (P2-10)
- Adjust the clutch lever free play (P2-12)
- Adjust the drive chain slack (P2-14)
- Fill the crankcase with the recommended grade oil to the proper level.

SAE 15W-40 API: SH / CD

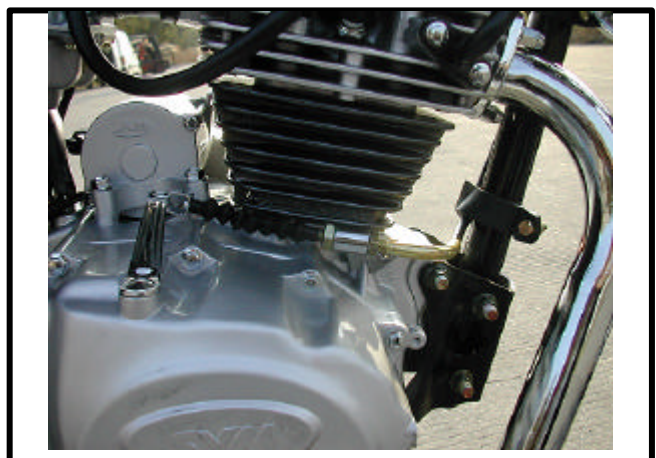

TROUBLE SHOOTING.....5-1	VALVE GUIDE REPLACEMENT5-8
SERVICE INFORMATION.....5-2	VALVE SEAT INSPECTION/REFACING5-9
CAM SHAFT REMOVAL5-3	VALVE SEAT GRINDING5-10
CYLINDER HEAD/ROCKER ARM REMOVAL5-4	CYLINDER HEAD ASSEMBLY.....5-13
CYLINDER HEAD DISASSEMBLY.....5-6	CYLINDER HEAD INSTALLATION.....5-14
VALVE/VALVE GUIDE INSPECTION.....5-7	CAM SHAFT INSTALLATION.....5-15

TROUBLE SHOOTING

LOW COMPRESSION

1. Valve

- Incorrect valve clearance
- Burned or bent valves
- Incorrect valve timing
- Broken valve spring

2. Cylinder head

- Leaking or damaged head gasket
- Warped or cranked cylinder head

HIGH COMPRESSION

- Excessive carbon buildup on piston or combustion chamber.

ABNORMAL NOISE

- Incorrect valve clearance
- Broken valve spring
- Worn rocker arm or camshaft
- Loose or worn cam chain
- Worn cam chain tensioner
- Worn cam sprocket teeth

SERVICE INFORMATION

GENERAL INSTRUCTIONS

Camshaft, rocker arm shaft and rocker arm can be serviced with the engine installed on the frame.

Camshaft lubrication oil is fed to the cylinder head through an oil control orifice in the engine case.

Be sure this orifice is not clogged and the O-ring and dowel pins are in place before installing the cylinder head.

During assembly, apply molybdenum disulfide grease to the camshaft bearings, and pour clean engine oil into the cylinder head.

TORQUE VALUES

Cylinder head bolt	280-300 kgf . cm
Cylinder 6mm bolt	140 -180 kgf . cm
Cam sprocket	80-120 kgf . cm

SPECIFICATIONS

ITEM			STANDARD SERVICE	LIMIT
Camshaft	Cam lift	IN	32.382mm	31.25mm below
		EX	31.987mm	30.87mm below
	Runout			0.02mm
Rocker arm I.D.		I.D.	12.000 ~ 12.018mm	12.018mm above
Rocker arm shaft		O.D.	11.966 ~ 11.984 mm	11.966mm below
Valve spring	Free length		39.95 ~ 40.55mm	39mm below
	Stall length		36.21mm 18.17 ± 1.82kgf 29.21mm 57 ± 4.28 kgf	
Valve clearance			(IN)0.06 ± 0.02mm (EX)0.10 ± 0.02mm	
Valve guide	O.D.	IN	5.450 ~ 5.465mm	5.42mm
		EX	5.430 ~ 5.455mm	5.40mm
	Guide I.D.	IN	5.475 ~ 5.485mm	5.50mm
		EX	5.475 ~ 5.485mm	5.50mm
	Stem to guide Clearance	IN	0.010 ~ 0.035mm	0.08mm
		EX	0.03 ~ 0.055mm	0.10mm
Valve seat width			1.45 ~ 1.15mm	1.6mm

CAMSHAFT REMOVAL

NOTE:

The camshaft, rocker arm and rocker arm shaft can be serviced with the engine installed on the frame.

Remove the cam sprocket cover.

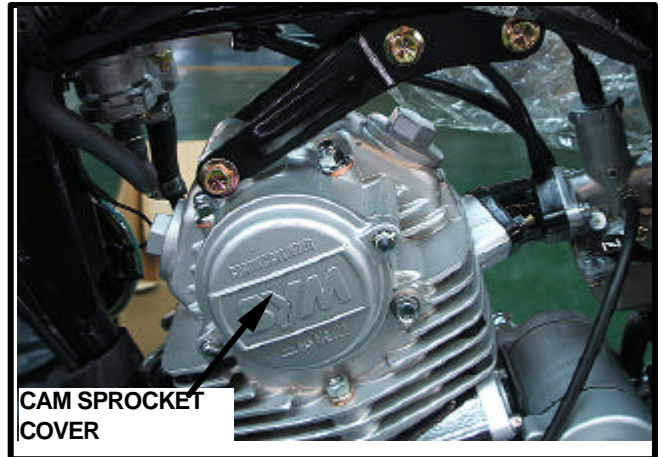

Remove the crankshaft hole cap and the timing inspection hole cap.

Rotate the generator rotor counterclockwise and locate the piston at the T.D.C. of the compressing stroke.

Remove the cam sprocket bolts and remove the cam sprocket.

NOTE:

Take care not to drop then bolt into the crankcase.

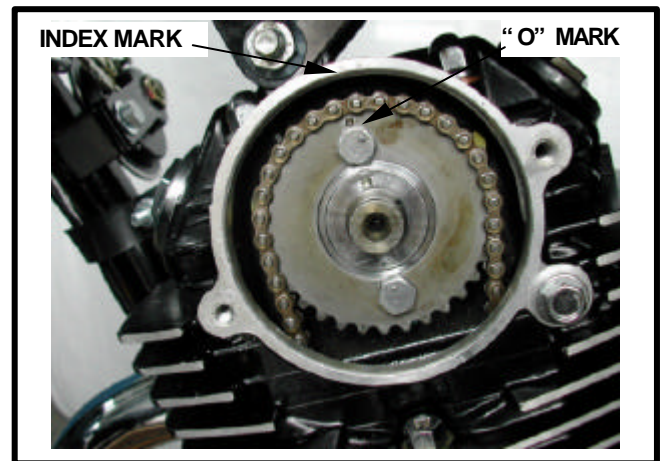

Suspend the cam chain with a wire to prevent it from falling into the crankcase.

Remove the camshaft.



CYLINDER HEAD

REMOVAL

- Remove the cam chain tensioner bolt.
- Remove the 8mm bolt.
- Remove the 4 cylinder head nuts.
- Remove the dowel pins.
- Remove cam chain tensioner.
- Remove the cylinder head.

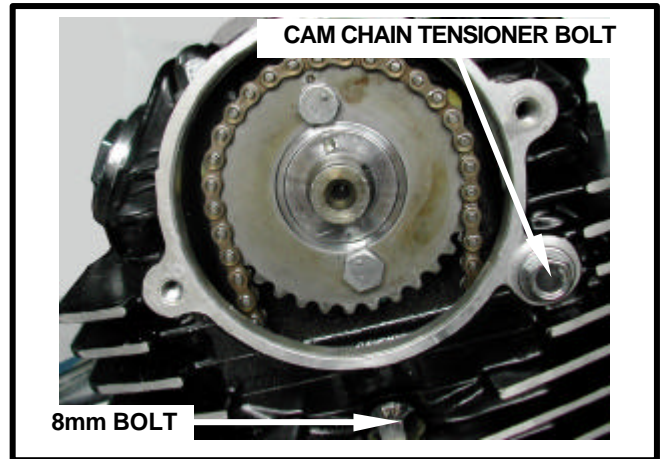

Remove the rocker arm shaft.



Remove the rocker arms.

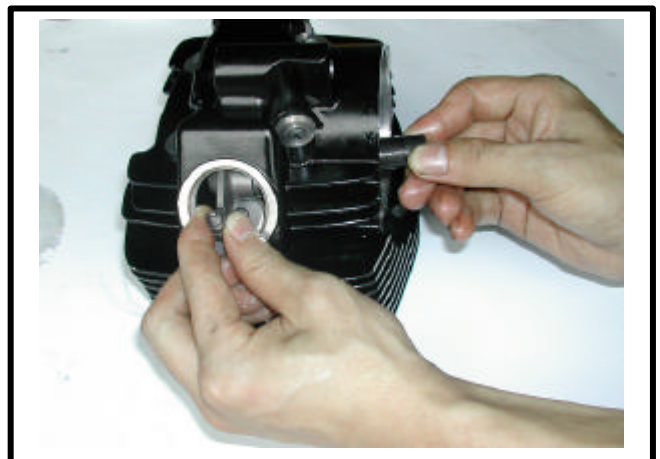
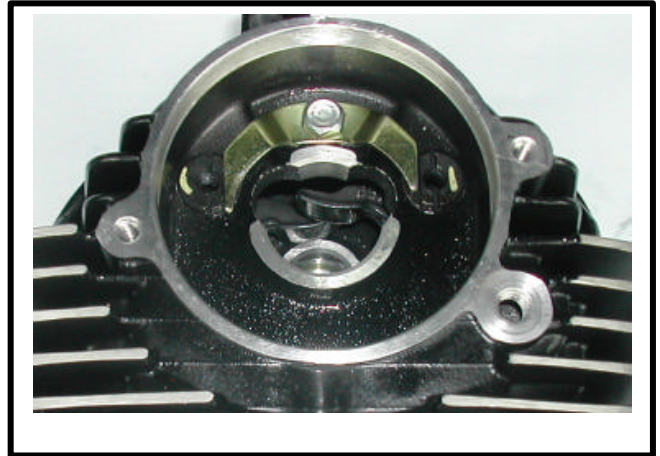

CAMSHAFT INSPECTION

Inspect the cams of the camshaft for wear.

Service limit:

Inlet: 31.25mm
Exhaust: 30.87mm

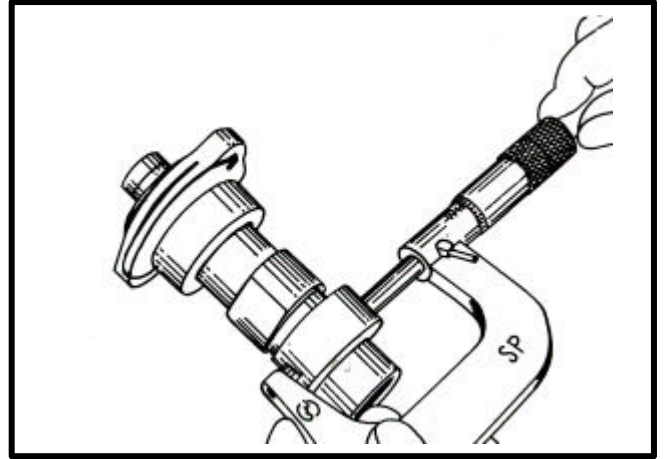

ROCKER ARM INSPECTION

Inspect the rocker arm I.D. and the rocker arm for wear, damage or clogged oil holes.

Rocker arm I.D.

Service limit: 12.018mm

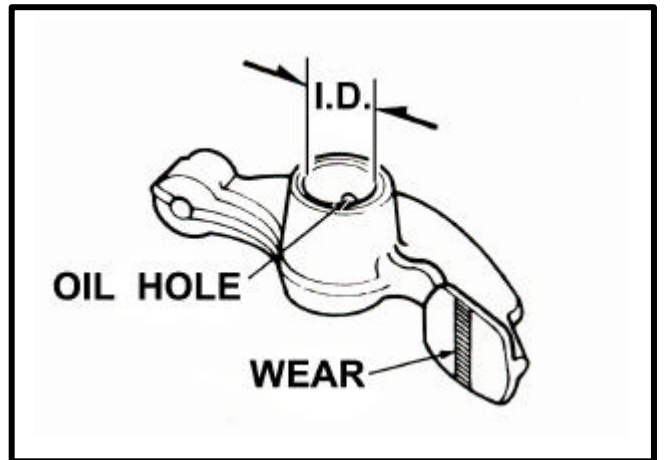

ROCKER ARM SHAFT INSPECTION

Inspect rocker arm shaft for wear or damage.

Rocker arm shaft O.D.

Service limit : 11.966mm

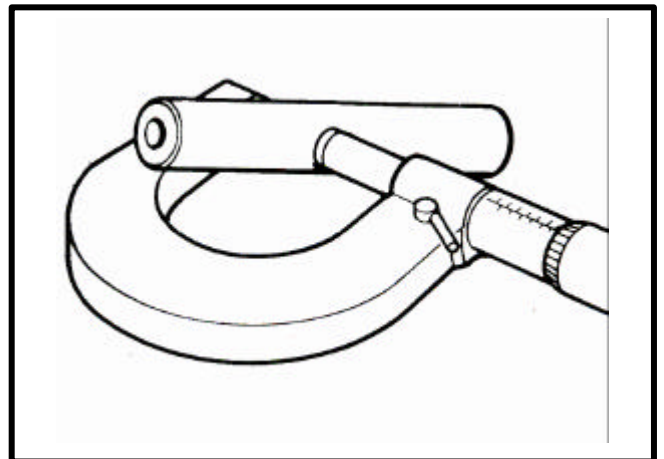

CYLINDER HEAD DISASSEMBLY

Remove carbon deposits from the combustion chamber. Remove valve spring and valve spring and valve with a valve spring compressor.

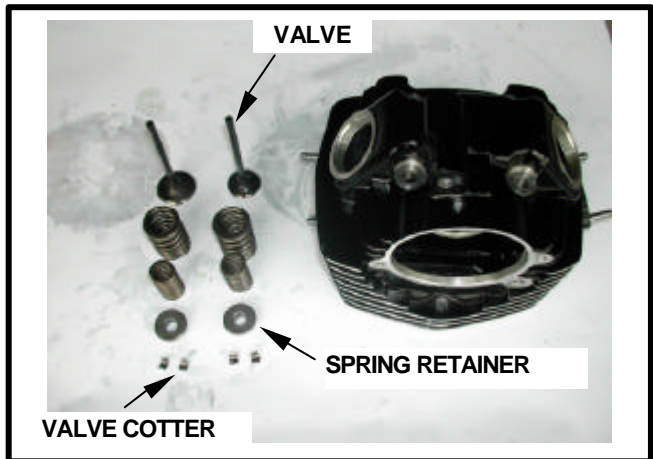

CYLINDER HEAD INSPECTION

Remove gasket from cylinder head with a scraper.
Check the cylinder head for crack.
Check the cylinder head for warpage with a straight edge and a feeler gauge.
Service limit: 0.10mm

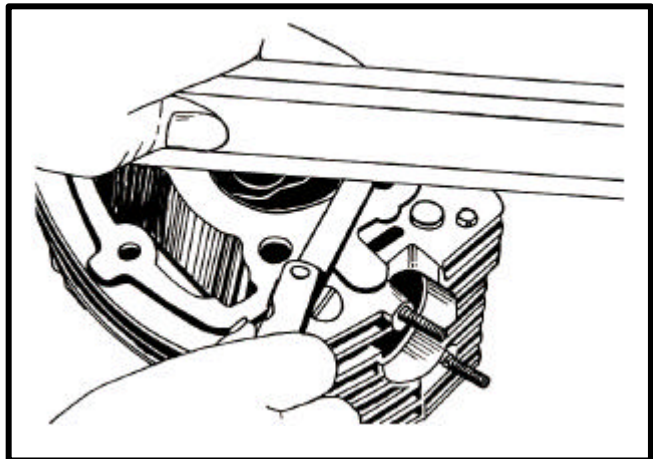

VALVE SPRING INSPECTION

Measure the free length of the inner and outer valve spring.
Service limit: 39mm below

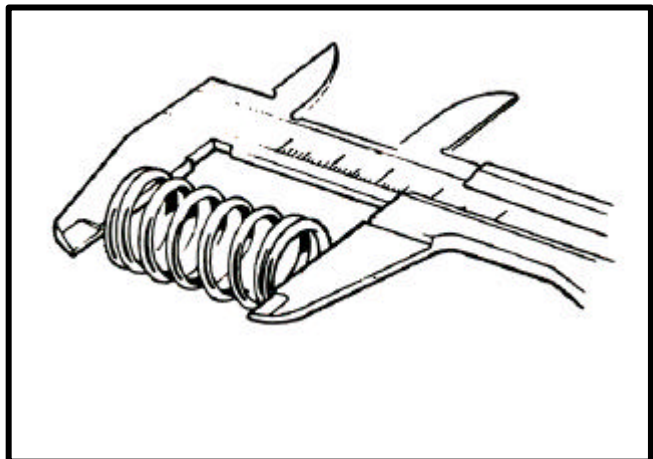

VALVE/VALVE GUIDE

INSPECTION

Inspect valves for scratches, burning or wear.

Check the valve movement in the guide.

Measure the valve stem O.D.

Service limit:

Intake: 5.42mm

Exhaust: 5.40mm

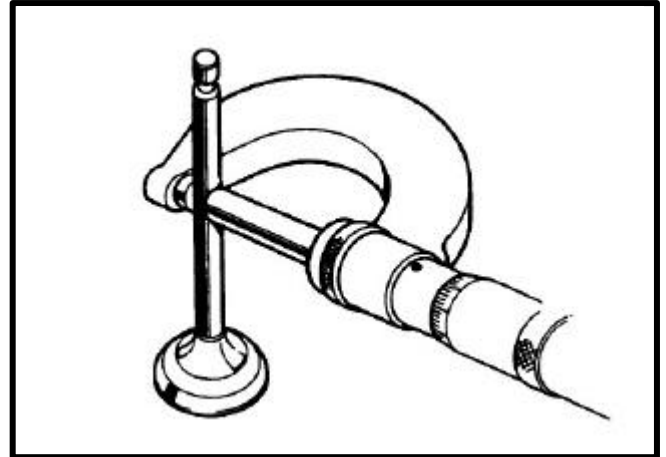

NOTE:

Remove any carbon buildup before checking the valve guide I.D.

Guide I.D. service limit

Intake: 5.50mm

Exhaust : 5.50mm

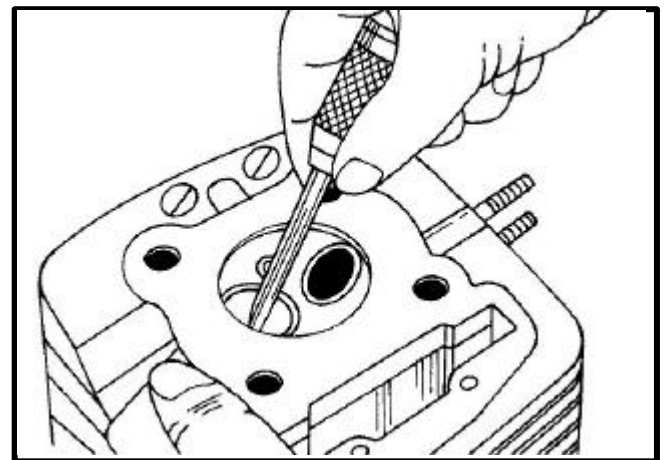

Measure the valve guide I.D. and calculate the stem to guide clearance.

Service limit:

Intake: 0.08mm

Exhaust: 0.10mm

If the stem to guide clearance exceeds the service limit, replace the valve or guide to fit.

NOTE:

The guide must be reamed when replacing a new one.

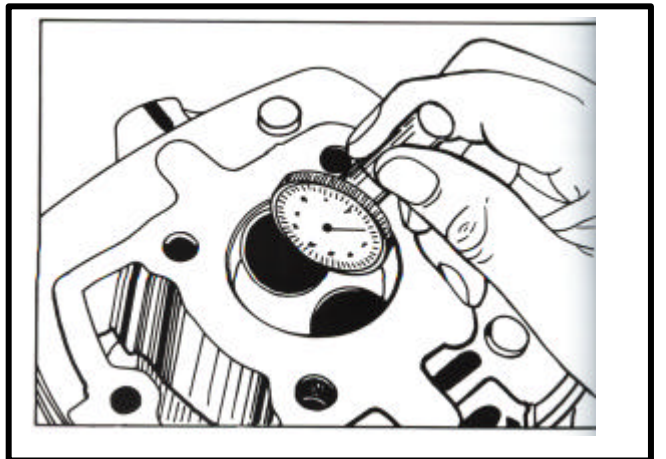

VALVE GUIDE REPLACEMENT

Drive out the valve guide from the combustion chamber side with a 5mm valve guide remover.

NOTE:

When driving out the valve guide, do not damage the cylinder head.

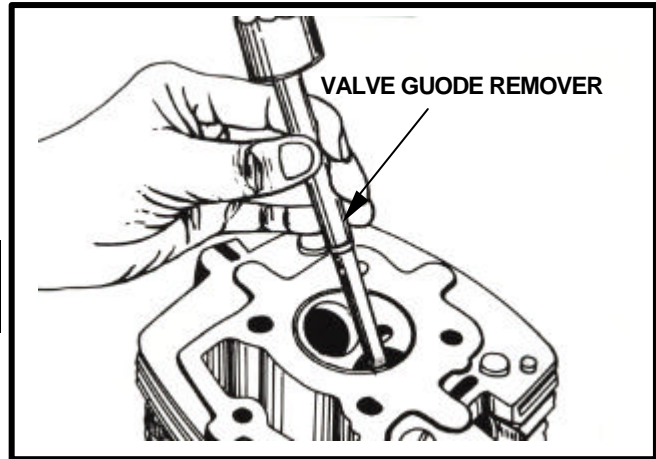

Install the new valve guide from the top of the cylinder head, and ream it with a reamer, then clean the cylinder head.

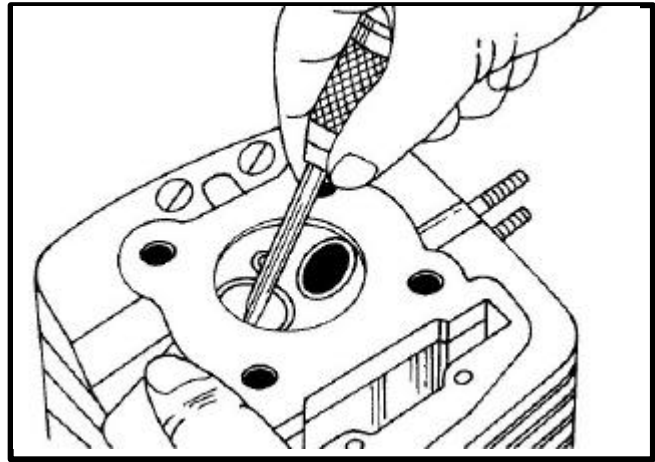

5. CYLINDER HEAD/ VALVE

VALVE SEAT INSPECTION/ REFACING

Clean intake and exhaust valves to remove carbon deposits.

Apply a light coating of prussian blue to each valve face.

Insert each valve into the guide and rotate them two cycles.

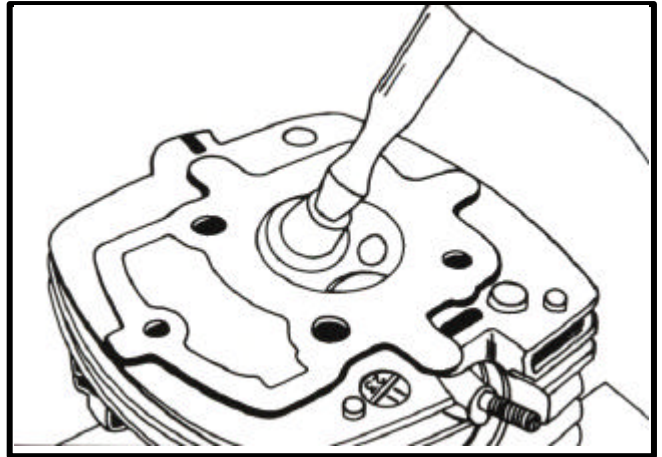

Remove the valve and inspect the face.

CAUTION:

If the valve face is burned or damaged or unevenly, replace the valve.

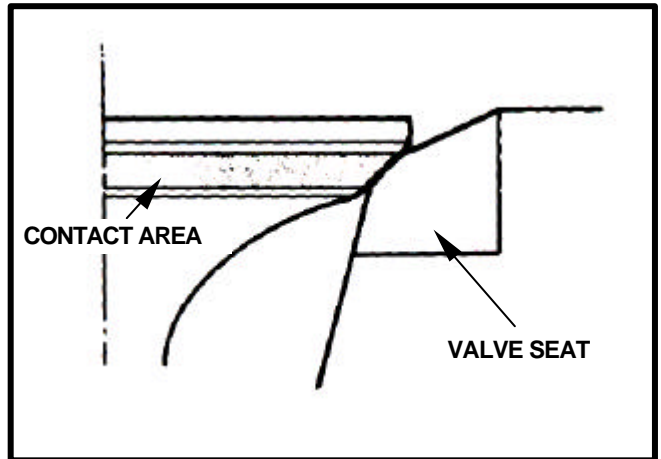

Inspect the valve seat.

If the seat is too wide or too narrow, the seat must be refinished.

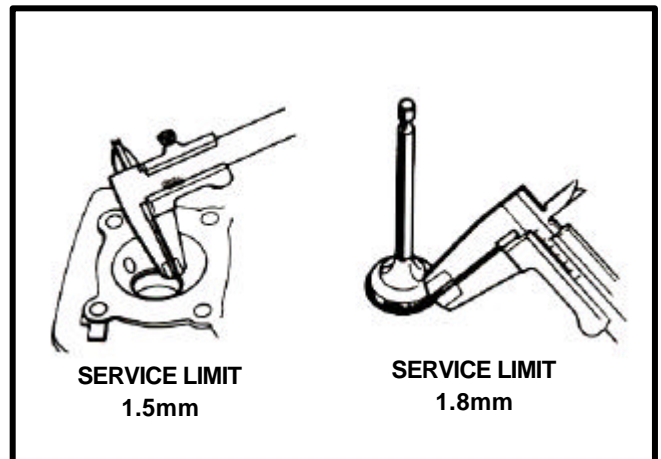

VALVE SEAT GRINDING

NOTE:

Follow the instructions described in the cutter instruction manual.

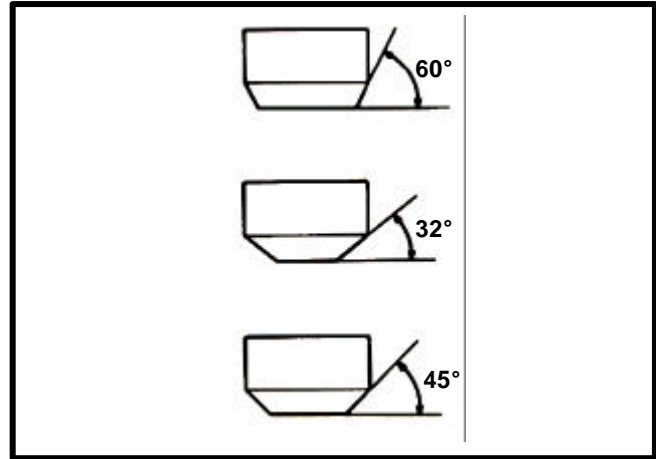

Remove any roughness from the seat by applying 4~5 kg pressure, turning the cutter left and right.

NOTE:

Add engine oil to the face when operating.

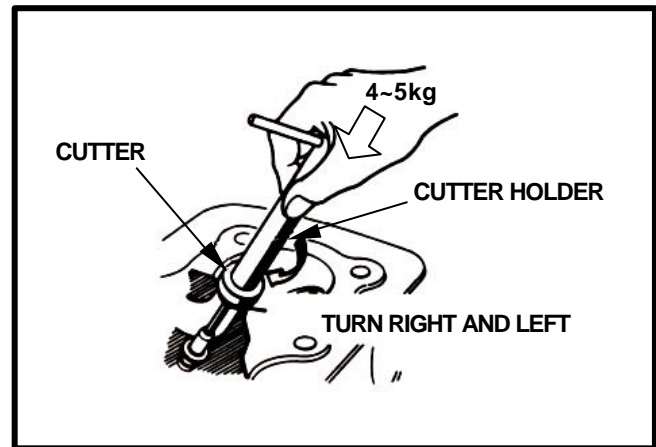

Using a 45 degree cutter,remove any roughness from the seat.

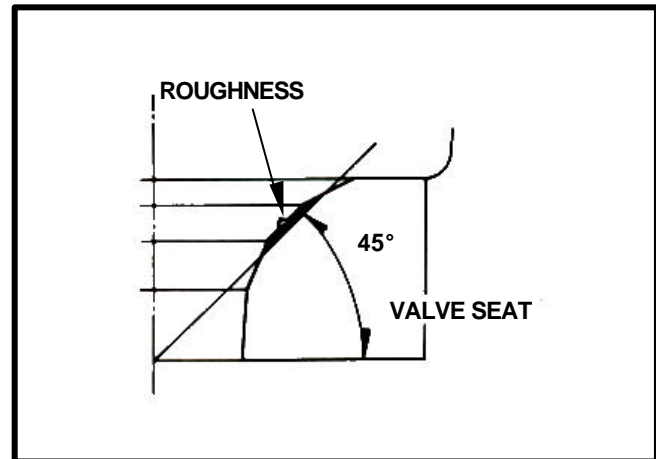

5. CYLINDER HEAD/ VALVE

Using a 32 degree cutter, remove 1/4 of the existing valve seat material.

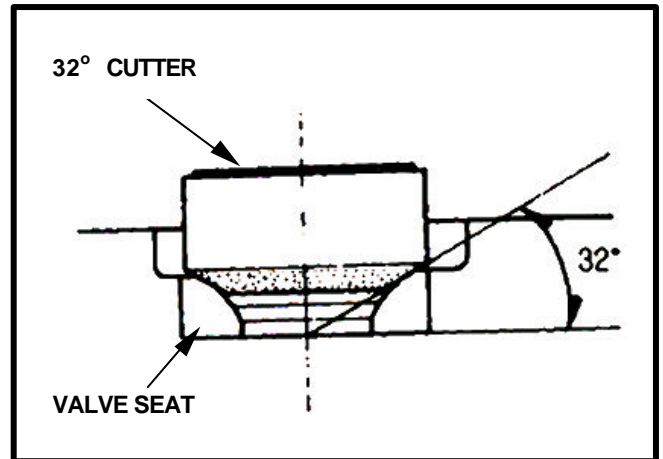

Remove the bottom 1/4 of the old seat by using a 60 degree cutter.

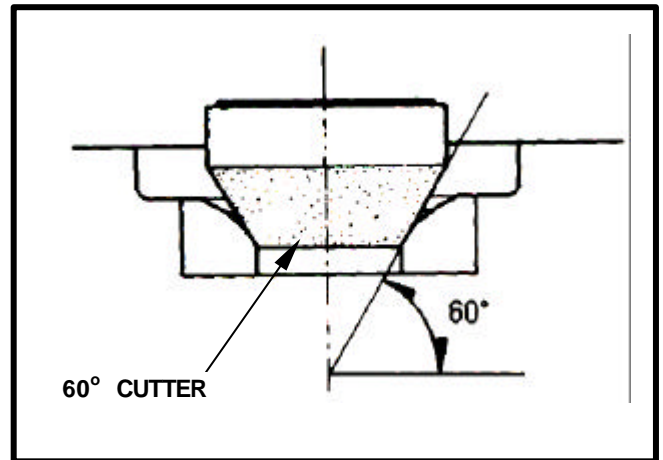

Finish the seat to the proper width by using a 45 degree cutter.

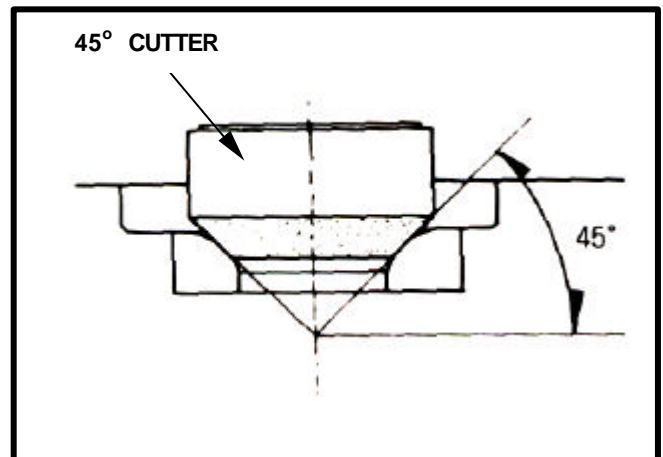

If the contact area is too high on the valve, the seat must be lowered using a 37.5 degree cutter, then finish with a 45 degree cutter.

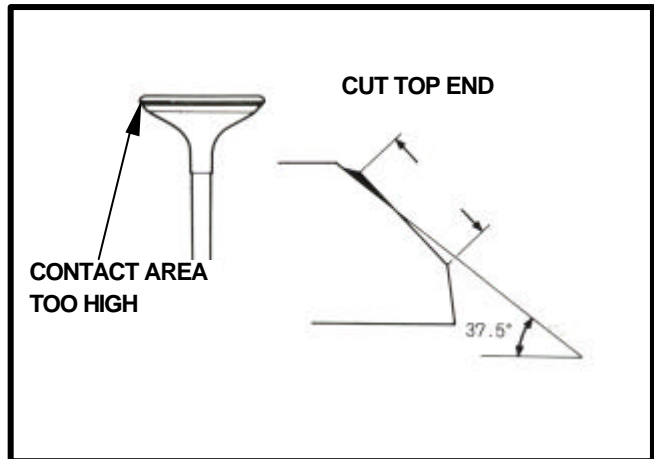

If the contact area is too low on the valve, the seat must be raised using a 63.5 degree cutter, then finish with a 45 degree cutter.

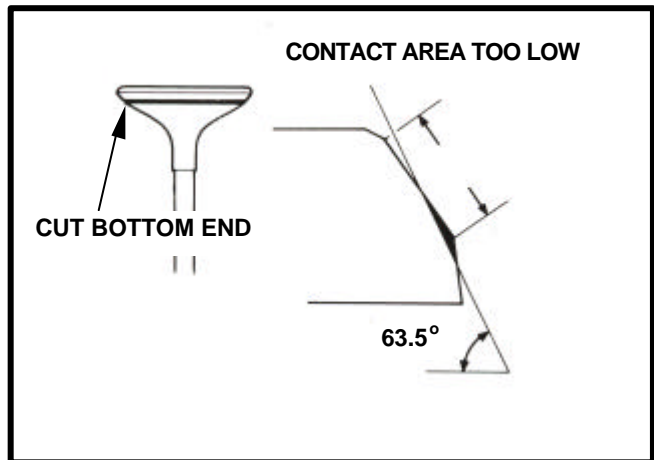

After cutting the seat, apply lapping compound to the valve face, and lap the valve using light pressure.

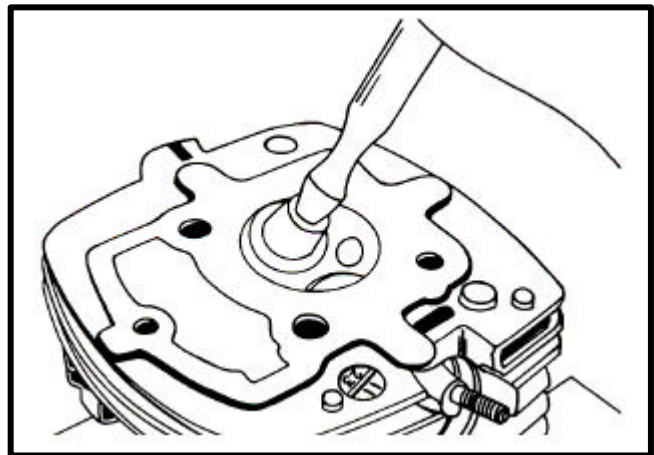

CYLINDER HEAD ASSEMBLY

Compress the valve springs with a valve spring compressor and install the valve cotters into the valve retainer.

CAUTION:

Do not compress the valve spring more than necessary.

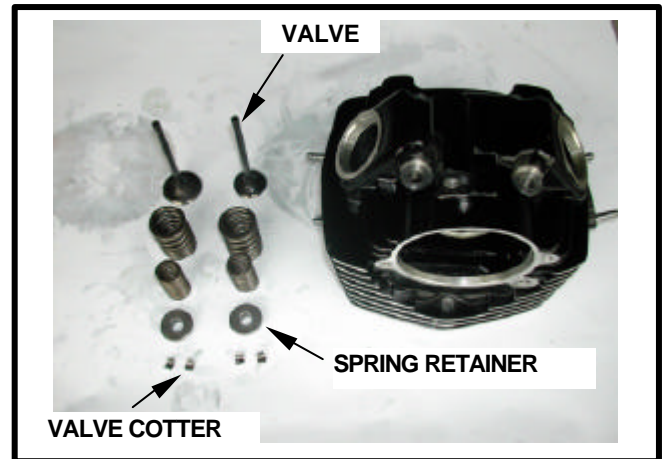

NOTE:

Install a new valve stem seal when assembling.

Lubricate each valve stem with the engine oil then insert them into the guides.

Install the valve spring and retainers.

NOTE:

Install the valve springs with the tightly wound coils facing the cylinder head.



Tap the valve stems gently with a plastic hammer to firmly seat the cotters.



CYLINDER HEAD INSTALLATION CAMSHAFT AND CAMSPROCKET ASSEMBLY

NOTE:

Rocker arms must be installed at the right position.

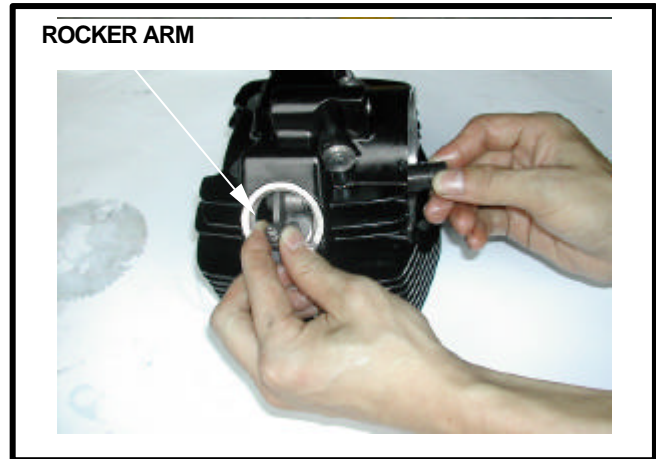

Clean the cylinder head gasket surface of any gasket material.
Install the new gasket, O-ring and dowel pins and chain guide.

NOTE:

Do not allow dust and dirt to enter the cylinder.

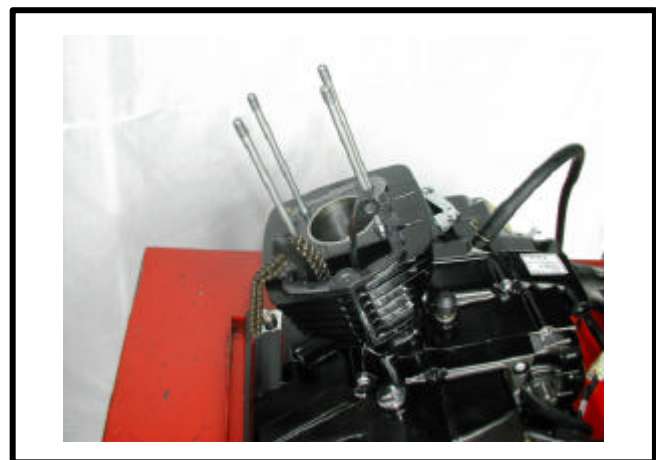

Install the cylinder head.

NOTE:

Support the cam chain to keep it from falling into the crankcase.

Install the cam chain tensioner set and bolt and washer.

Install dowel pins.

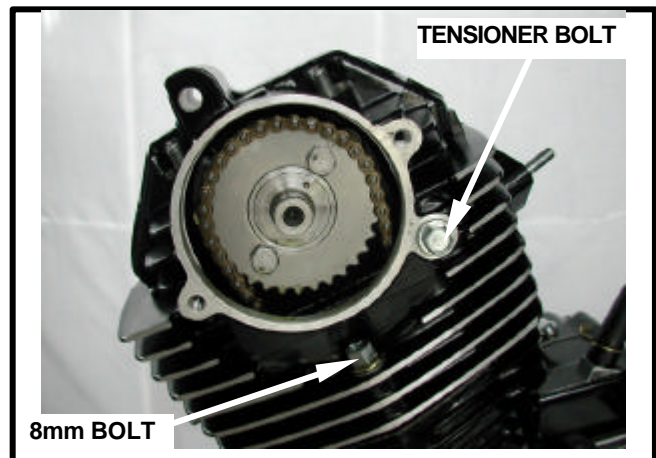

CAM SHAFT

INSTALLATION

Rotate the generator rotor and align the "T" mark with the index mark.

Install the camshaft comp.

When installing camshaft set, please take care that the line on the camsprocket should be in parallel with the surface of cylinder head. (The IN/EX cam should be faced down).

Install the camshaft holder.

Install the cylinder head nuts.

TORQUE: 280 ~ 300 kgf. cm

CAUTION:

The cap nut of the four holder nuts must be installed at the left-front side.

Install the 6mm bolts.

Install the cam chain chain tensioner.

Install the auto-tensioner. (Lock the spring cap bolt first.)

Release the auto-tensioner lock bolt.

Adjust the valve clearance. (2-7)

Install the cylinder head cover.

Install the R/L cylinder head side cover.

Install the 6mm special bolts.

NOTE:

If the cylinder head side cover gasket is damaged or broken, replace with a new one.

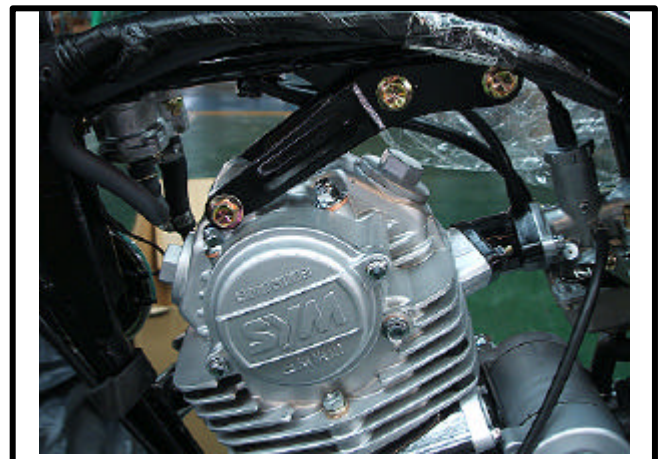
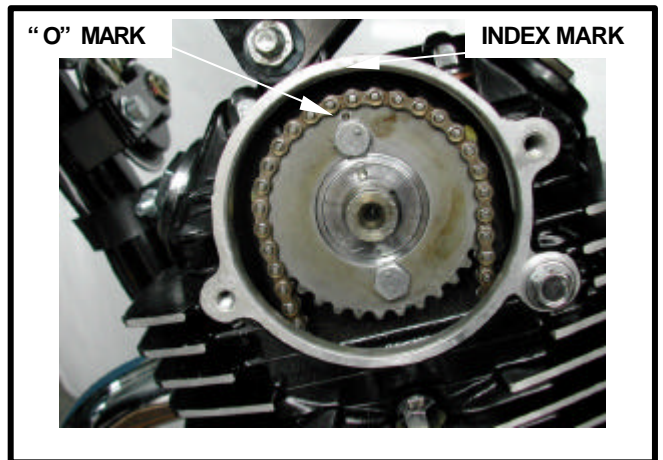

TROUBLE SHOOTING.....6-1	PISTON/PISTON RING INSPECTION..... 6-3
SERVICE INFORMATION.....6-1	PISTON RING INSTALLATION..... 6-5
CYLINDER REMOVAL.....6-2	PISTON INSTALLATION..... 6-6
PISTON REMOVAL.....6-3	CYLINDER INSTALLATION..... 6-6

TROUBLE SHOOTING

LOW COMPRESSION

1. Worn cylinder or piston rings.

EXCESSIVE SMOKE

1. Worn cylinder, piston or piston rings.
2. Improper installation of piston rings.
3. Scored or scratched piston or cylinder wall.

OVERHEATING

1. Excessive carbon build-up on piston or combustion chamber wall.

KNOCKING OR ABNORMAL NOISE

1. Worn piston or cylinder.
2. Excessive carbon build-up

SERVICE INFORMATION

GENERAL STRUCTIONS

ITEM		XS125-K		
		STANDARD SERVICE	LIMIT	
Cylinder	Cylinder I.D.	56.495 ~ 56.515mm	56.52mm	
	Runout	0.05mm	0.05mm	
	Taper	0.05mm	0.05mm	
Piston rings groove clearance	Piston ring to ring groove clearance	Top	0.025 ~ 0.055mm	0.060mm
		Second	0.015 ~ 0.040mm	0.045mm
	Piston ring End gap	Top	0.10 ~ 0.30mm	0.5mm
		Second	0.10 ~ 0.30mm	0.5mm
		Oil ring	0.30 ~ 0.90mm	
	Piston O.D.		56.485 ~ 56.505mm	56.48mm
	Piston pin bore		15.002 ~ 15.008mm	15.05mm
	Connecting rod small end I.D.		15.016 ~ 15.034mm	15.07mm
	Piston pin O.D.		14.994 ~ 15.000mm	14.994mm
	Piston ring thickness	Top	0.97 ~ 0.99mm	1.460mm
Second		0.97 ~ 0.99mm	1.460mm	
Cylinder to piston clearance		0.005 ~ 0.015mm	0.11mm	

CYLINDER REMOVAL

Remove the cylinder head.
 Remove the dowel pins and gasket.
 Remove the cylinder.

NOTE:

Avoid the dowel pins falling into the crankcase during removing the cylinder.

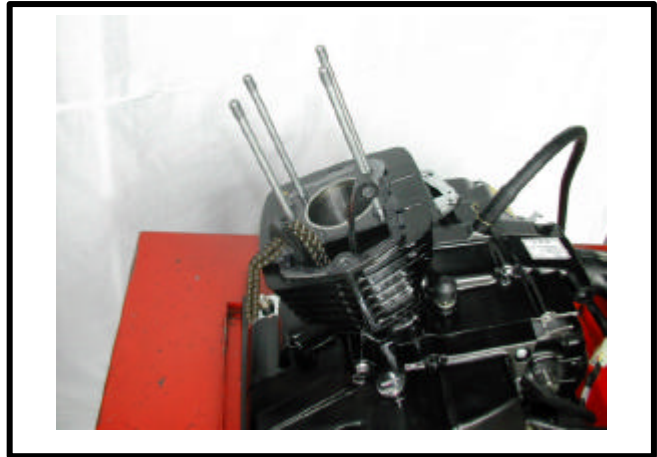

Remove the dowel pins and gasket.

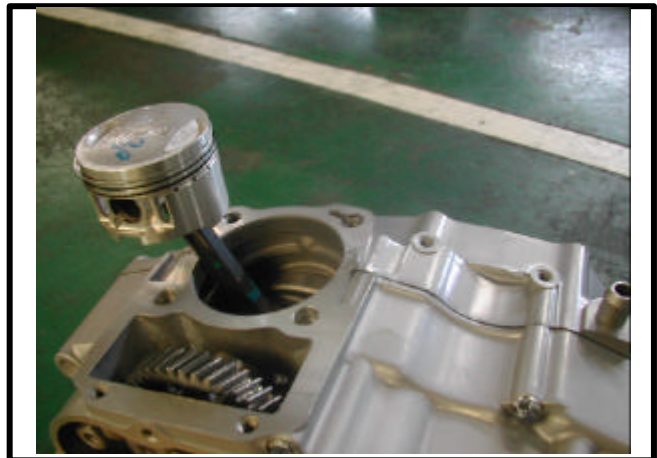

Clean the cylinder gasket surface of any gasket material.

NOTE:

Avoid damaging the cylinder gasket surface during this operation.

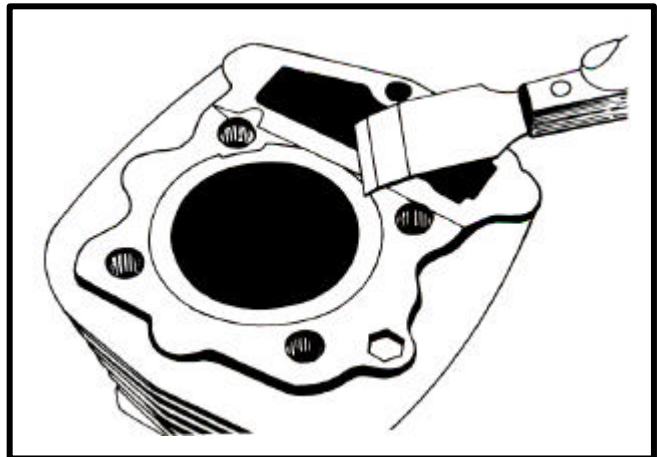

CYLINDER INSPECTION

Inspect the cylinder bore for wear or damage.
 Measure the cylinder I.D.

NOTE:

According to the right picture measure the cylinder runout.

Service limit:

ITEM	XS125-K
Runout	0.05mm
Taper	0.05mm
I.D.	56.52mm

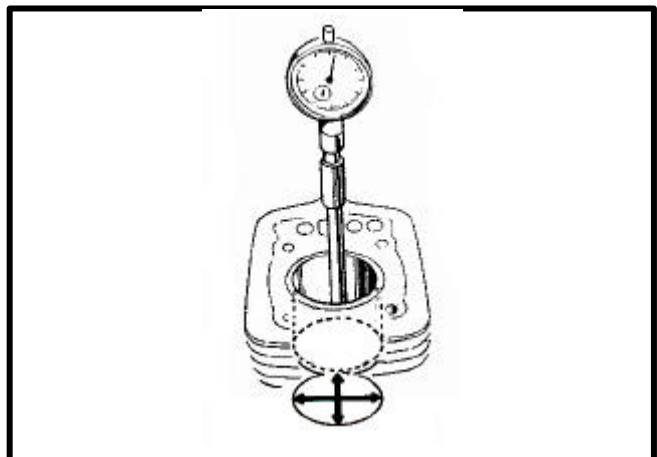

PISTON REMOVAL

Remove the piston pin clip with pliers.
Press the piston pin out of piston, remove the piston.

NOTE:

Avoid the clip falling into the crankcase.

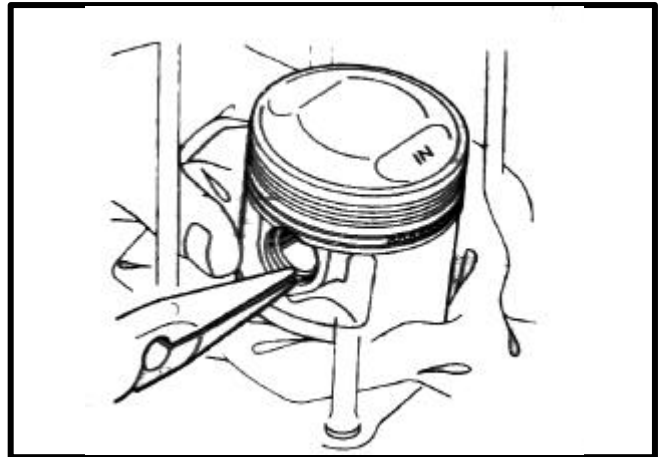

PISTON / PISTON RING

INSPECTION

Measure the piston ring-to-ring groove clearance.
Service limit .

Top ring: 0.13mm
Second ring: 0.12mm

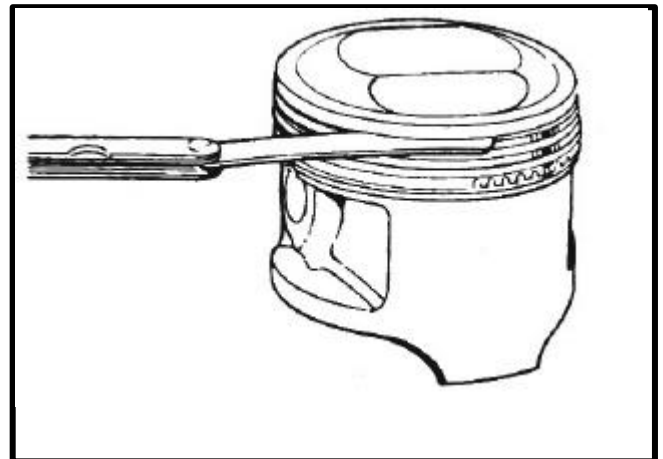

Remove the piston rings.
Inspect the piston for damage or cracks.
Inspect the piston groove for wear.

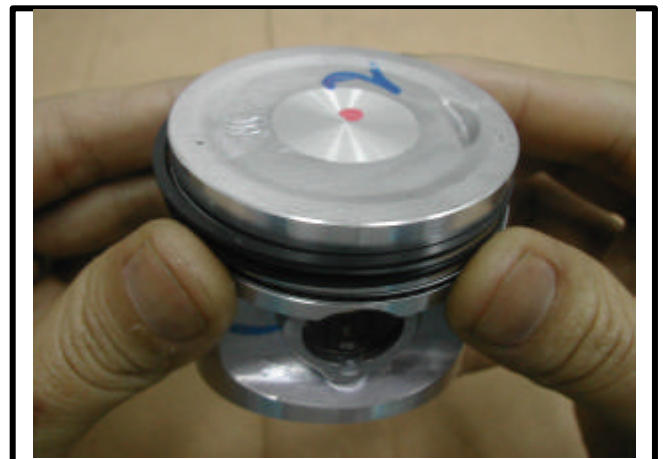

Insert each piston ring into the cylinder and measure the ring end gap.

Top / Second ring : 0.5mm

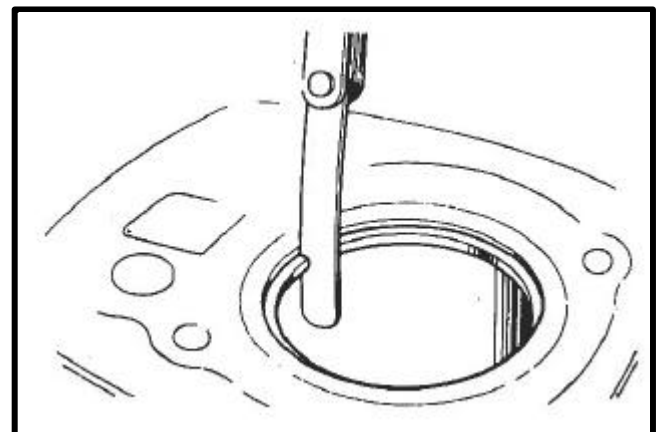

6. CYLINDER/PISTON



Measure the piston O.D. at the skirt.
Service limit: 56.48mm

NOTE:

Measure the piston O.D. at a point from the bottom.

Calculate the piston-to-cylinder clearance.
Service limit: 0.11mm

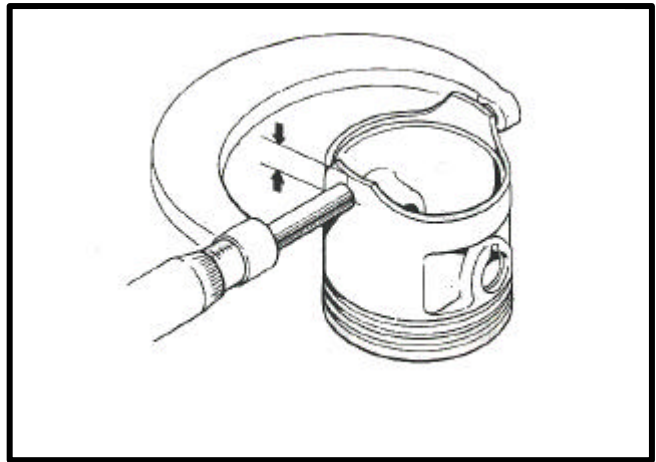

Measure the piston pin bore I.D.
Service limit: 15.05mm

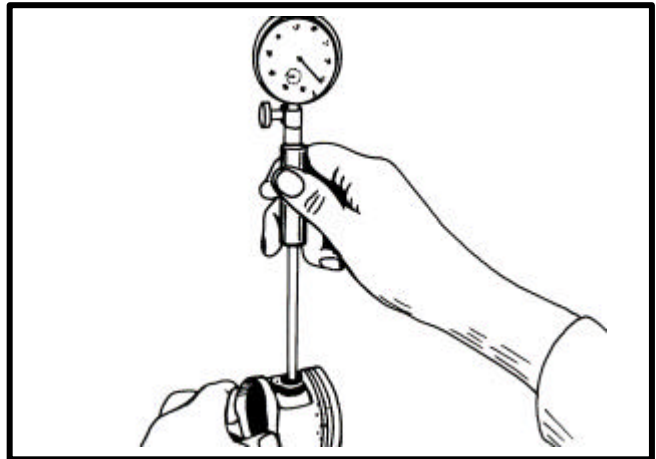

Measure the piston pin O.D.
Service limit: 14.994mm

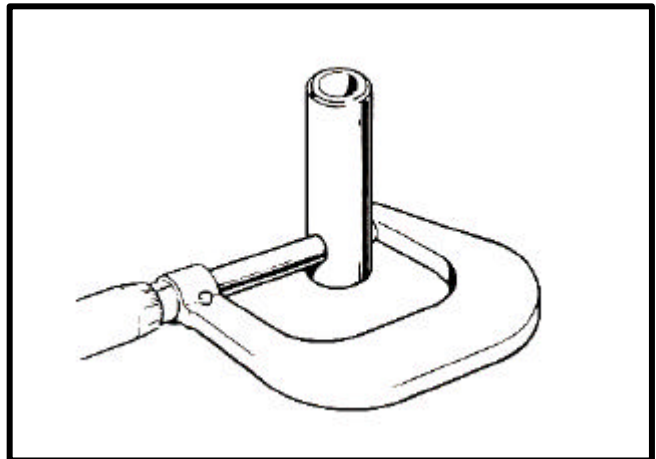

Measure the top/second ring thickness.
Service limit: 1.460mm

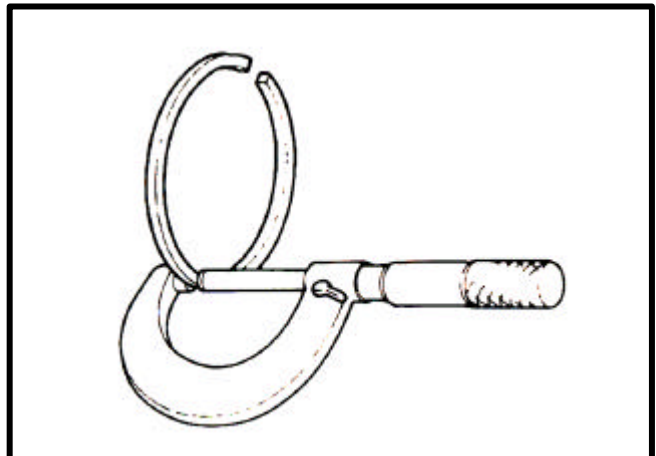

PISTON RING INSTALLATION

Install the piston rings.

NOTE:

- Avoid piston and piston ring damage during installation.
- All rings should be installed with the markings facing up.
- After installation, the piston rings should be free to rotate in the grooves.

Space the piston ring end gaps 120 degree apart.

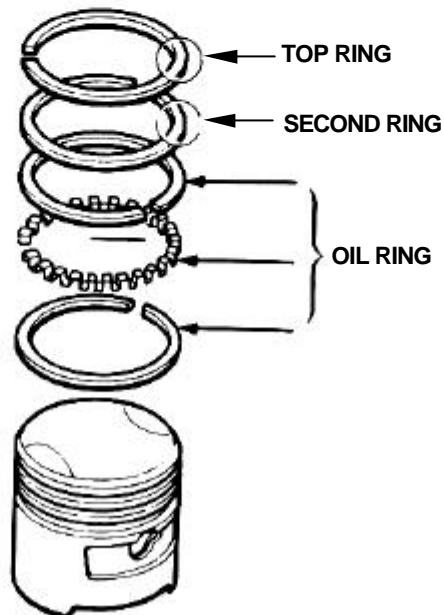
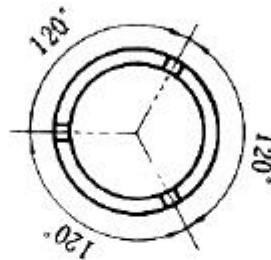
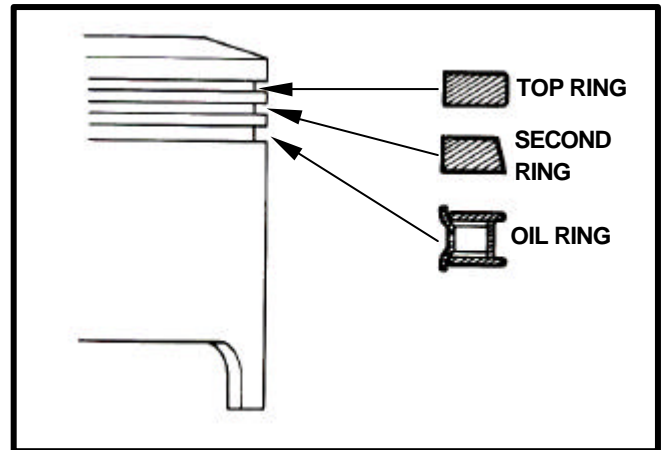

PISTON INSTALLATION

Install the piston, piston pin and piston pin clip.

NOTE:

- Position the "IN" mark on the piston to the carburetor side.
- Do not let the piston pin clip fall into the crankcase.

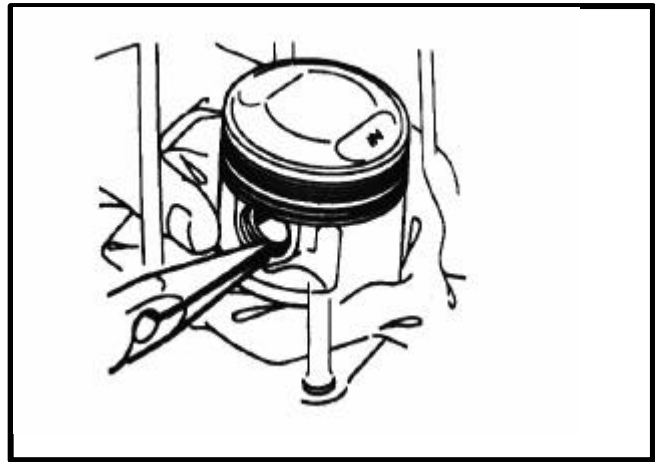

NOTE:

- Use new piston pin clip whenever disassembling.
- Do not align the piston pin clip end gap with the piston cutout.

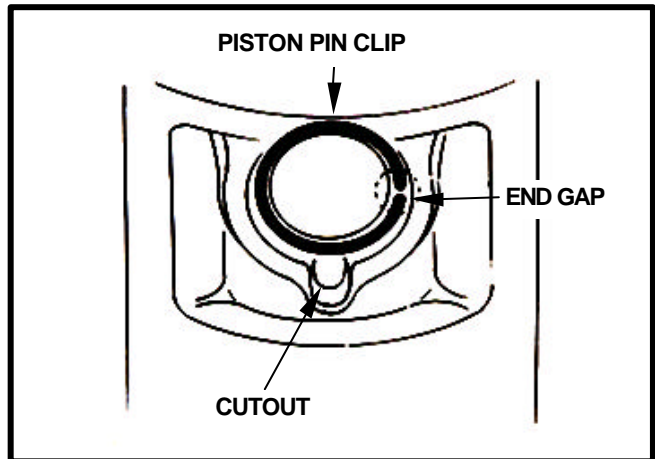

CYLINDER INSTALLATION

Install the cylinder gasket and dowel pins.
Clean the cylinder gasket surface of any gasket material.

NOTE:

Avoid damaging the cylinder gasket surface during this operation.

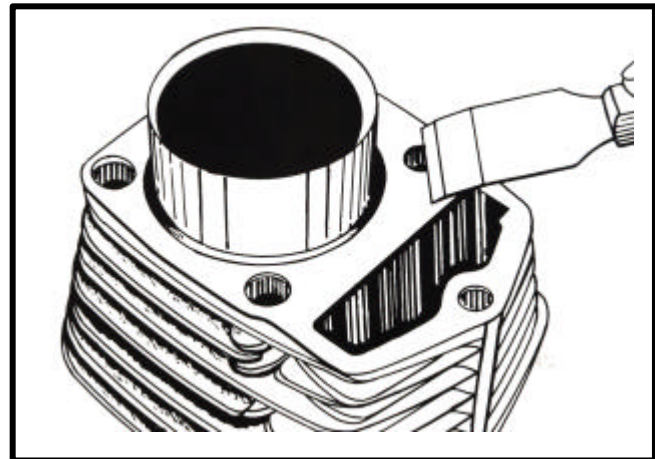

Install the cylinder.

NOTE:

Avoid piston and piston rings damage during installation.

Install the cylinder gasket and dowel pins.
Install the cylinder head.(5-8)

NOTE:

Coat the cylinder and piston with the engine oil before installing the cylinder.

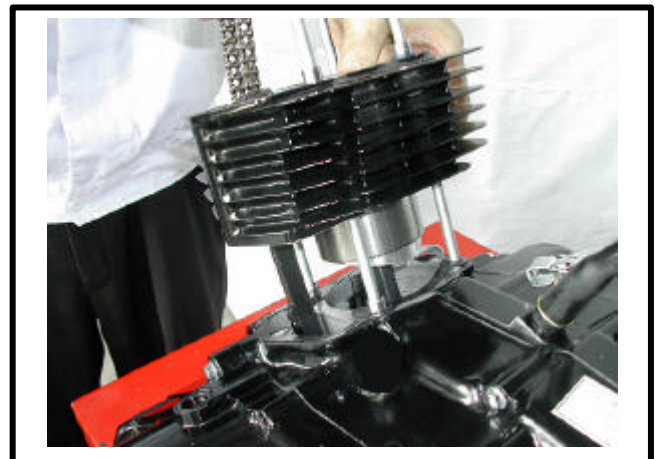

TROUBLE SHOOTING.....7-1	OIL PUMP7-7
SERVICE INFORMATION.....7-1	GEARSHIFT LINKAGE.....7-9
RIGHT CRANKCASE COVER REMOVAL ...7-2	RIGHT CRANKCASE COVER INSTALLATION.....7-11
CLUTCH.....7-2	

TROUBLE SHOOTING

Faulty clutch operation can be corrected by adjusting the clutch lever free play.

CLUTCH SPINS WHEN ACCELERATING

1. No free play
2. Discs worn
3. Spring weak

CLUTCH DISENGAGED (MOTORCYCLE CREEPS)

1. Too much free play
2. Plates warped

EXCESSIVE LEVER PRESSURE

1. Clutch cable kicked, damaged or dirty
2. Lifter mechanism damaged

HARD SHIFTING

1. Stopper plate bent
2. Improper clutch adjustment

GEARSHIFT PEDAL WON'T RETURN

1. Return spring broken or weak
2. Shift spindle bent

JUMPS OUT OF GEAR

1. Stopper arm spring broken

LOW OIL PRESSURE

1. Oil pump drive gear worn
2. Faulty oil pump

SERVICE INFORMATION

GENERAL INSTRUCTION

This section covers removal, installation and servicing of the clutch, oil pump, filter and gearshift linkage. All these operations can be accomplished with the engine in the frame.

COMMON TOOLS

- 22mm wrench socket
- Air wrench

TORQUE VALUES

- Right crankcase cover
- Kick starter pedal
- Step bar

- 80 ~ 120 kgf . cm
- 100 ~ 150 kgf . cm
- 180 ~ 200 kgf . cm

SPECIFICATIONS

ITEM		STANDARD SERVICE	LIMIT
Clutch	Leve Free play	10~20mm	-----
	Spring free length	30.6mm	28.6mm
	Friction plate thickness	3.0mm	2.8mm
	Clutch plate warpage	-----	0.2mm
Oil pump	Tip clearance	0.30mm	0.35mm
	Rotor-to-body clearance	0.25~0.31mm	0.40mm
	End clearance	0~0.06mm	0.11mm

RIGHT CRANKCASE COVER REMOVAL

Drain oil from the engine.
Disconnect the clutch cable.
Remove the kick starter arm.
Remove the right crankcase cover.

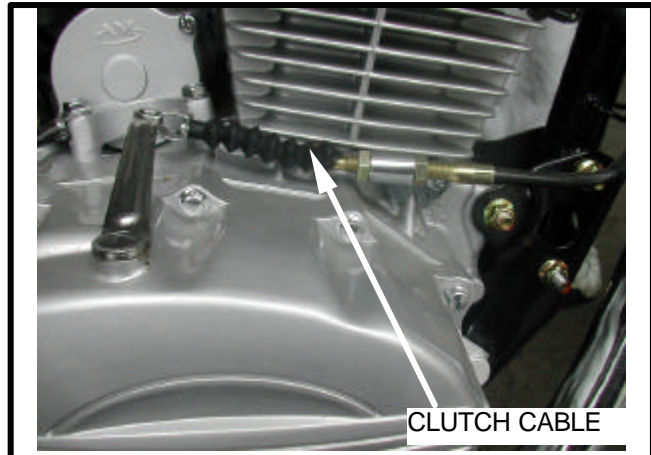

CLUTCH CLUTCH REMOVAL

Remove the clutch lifter rod.
Remove the oil filter rotor cover.

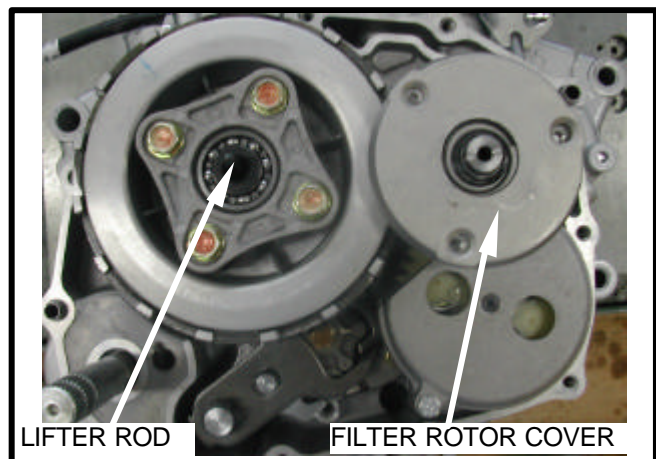

Remove the 16mm lock nut with a lock nut wrench.
Remove the oil filter rotor.

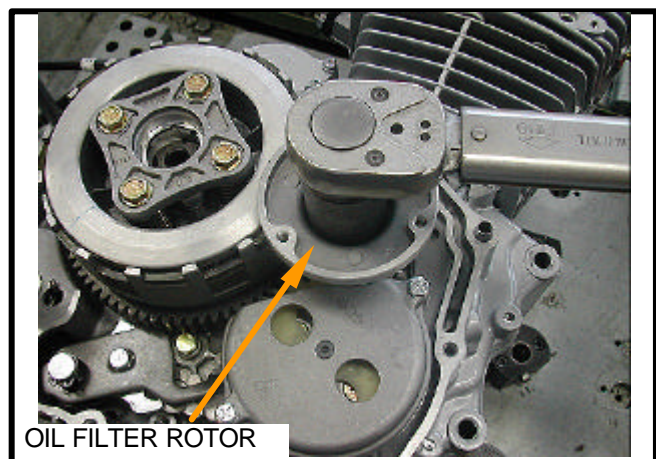

Remove the bearing, clutch bolt, clutch lifter plate and clutch spring.

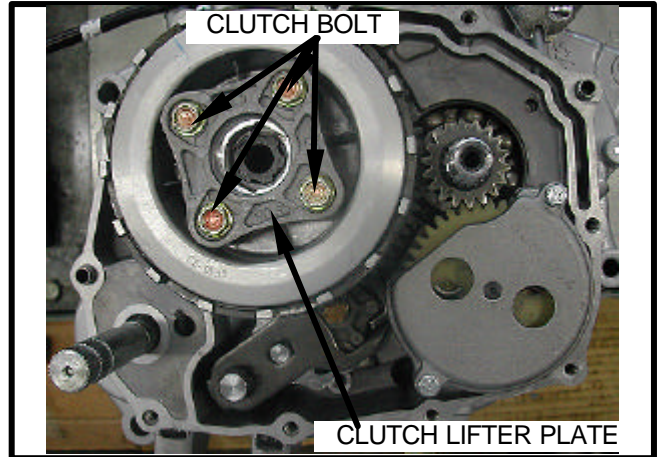

CLUTCH SPRING INSPECTION

Measure the clutch springs free length.
Service limit: 28.6mm

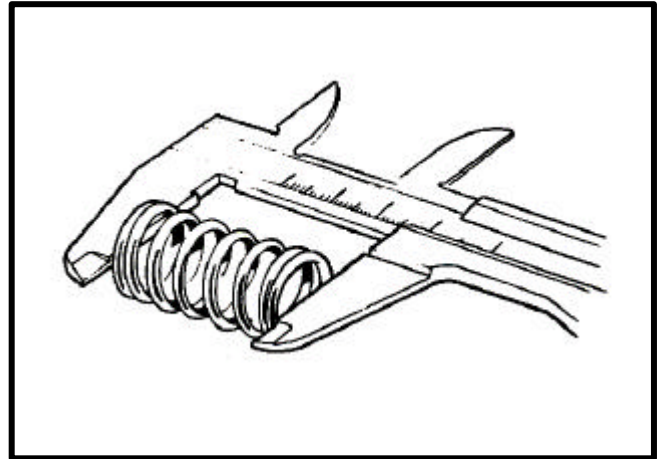

Remove the 20mm set ring.

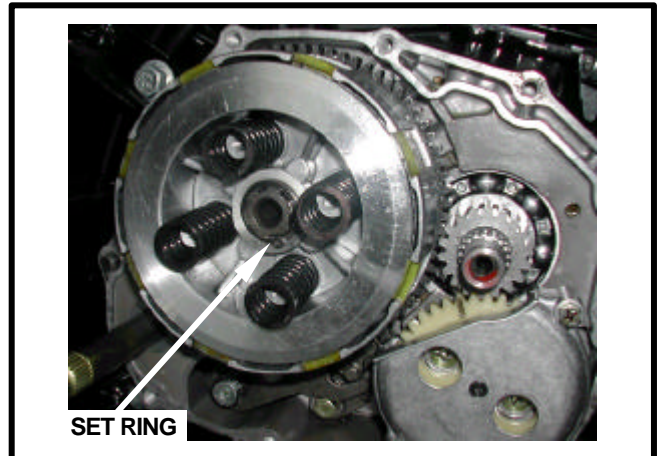

Remove the clutch center, disks, plates and pressure plate.

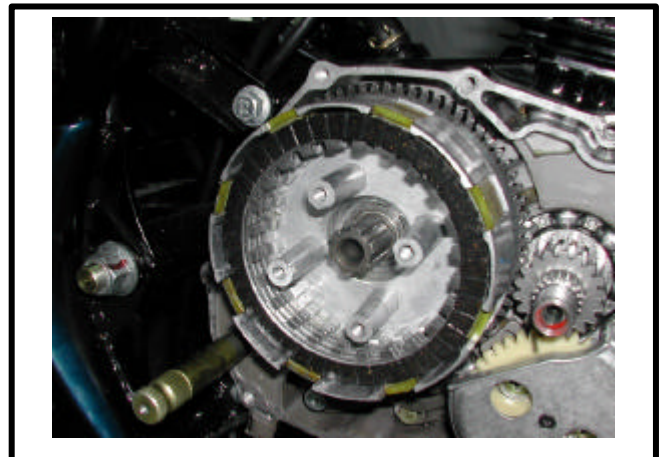

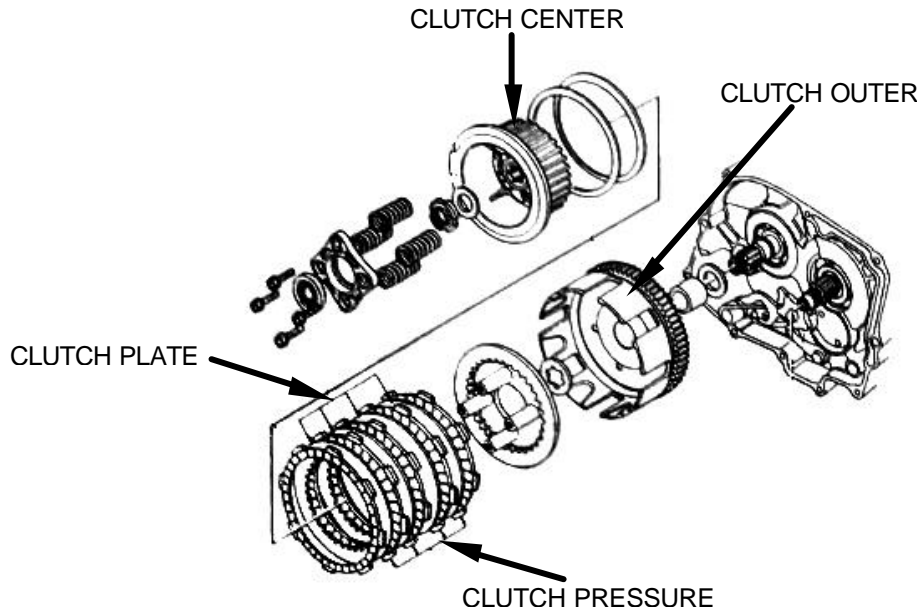

CLUTCH FRICTION DISC INSPECTION

Replace the clutch disks if they have any score or discoloration.

Measure the clutch friction disk thickness.

SERVICE LIMIT: 2.8mm

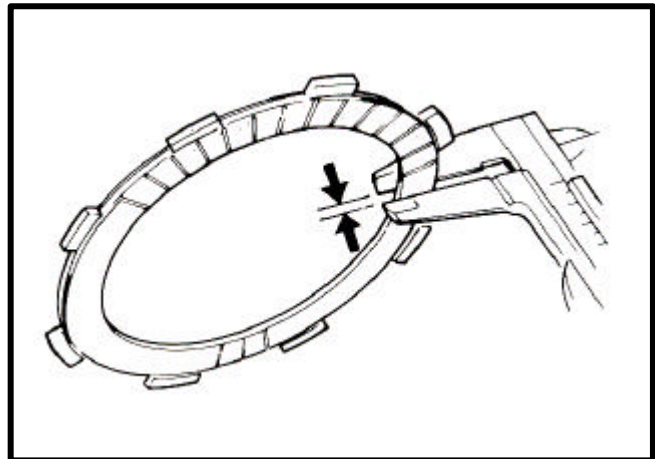

CLUTCH PLATE INSPECTION

Check the plates for warpage on a surface plate using a feeler gauge.

Service limit: 0.2mm

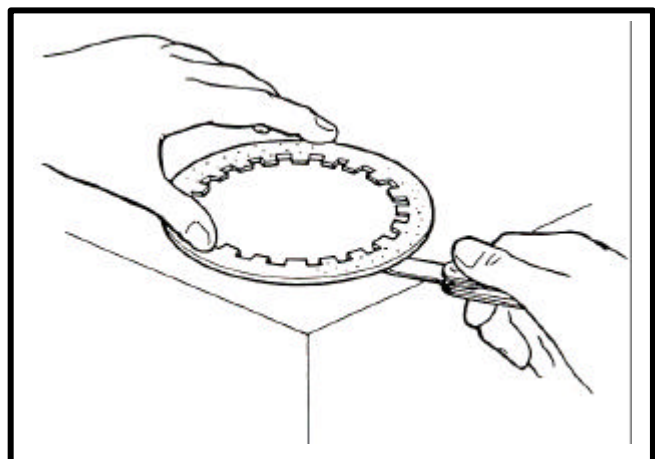

Remove the 20 mm washer and clutch outer.

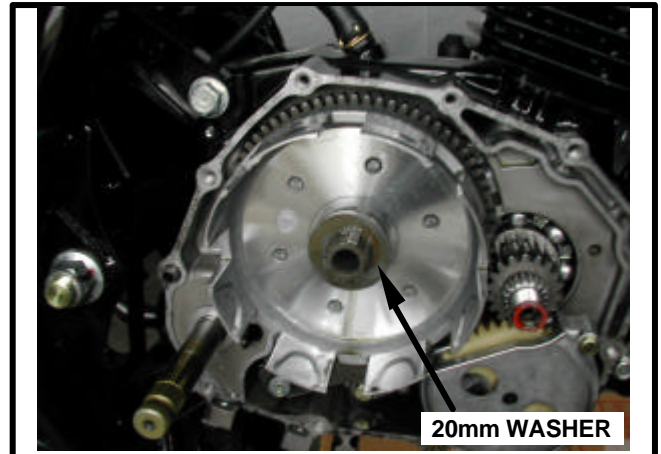

CLUTCH OUTER INSPECTION

Check the clutch outer for cracks or indentation.



CLUTCH OUTER INSTALLATION

Install the clutch outer, 20mm washer on the main shaft.

NOTE:

When installing the washer, it should fit with the main shaft groove.

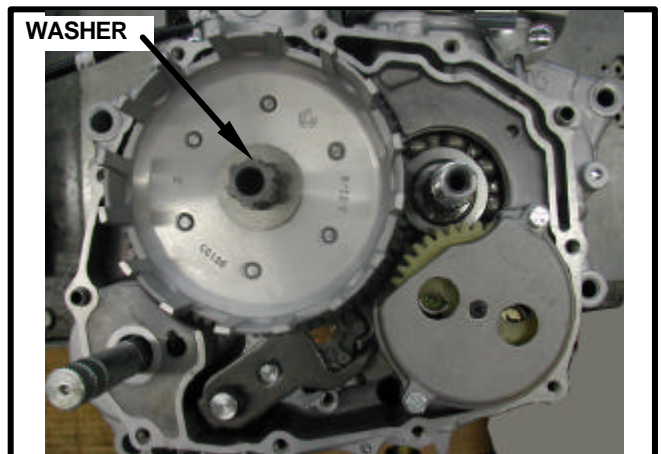

Install the clutch pressure plate, friction discs, clutch plates and clutch center.

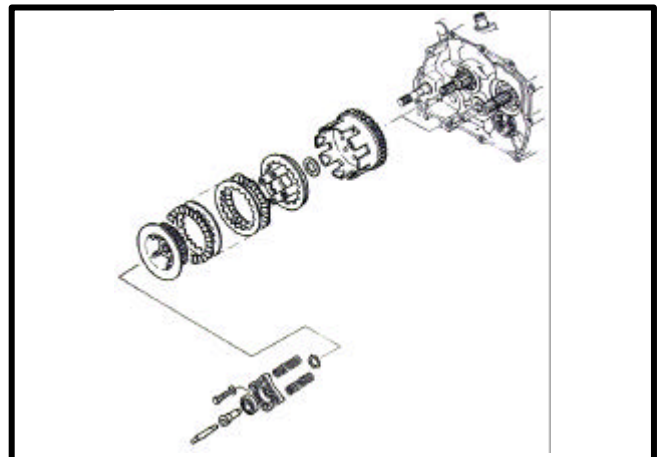

7. CLUTCH/OIL PUMP/GEAR SHIFT



Install and tighten the 20mm set ring.

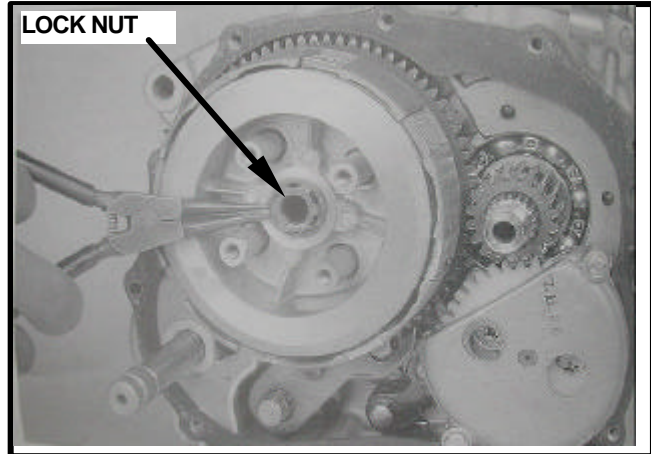

Install the clutch springs, lifter plate and tighten the bolts.

Install the bearing.

NOTE:

Tighten the bolts in a crisscross pattern in two or three steps.

TORQUE :80-120 kgf · cm

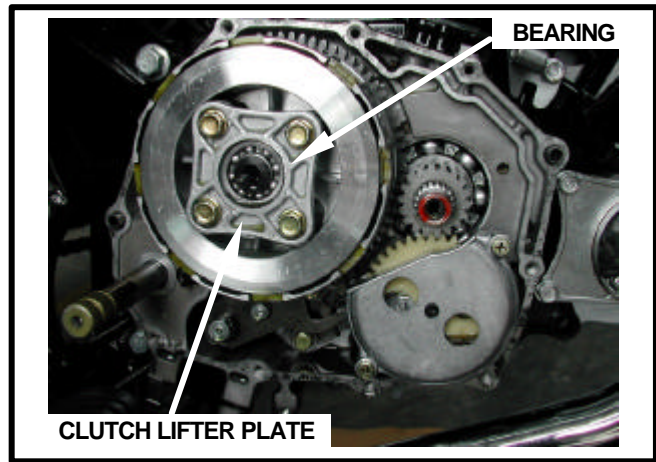

Install the oil filter rotor.

Install the lock washer and 16mm lock nut.

Tighten the 16mm lock nut.

TORQUE :400-500 kgf · cm

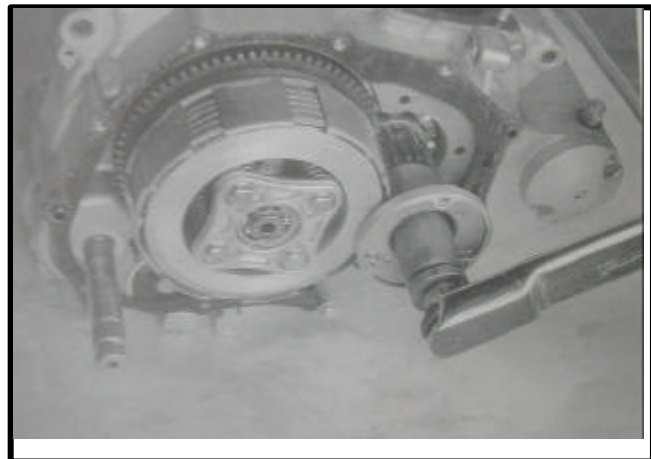

Install the filter rotor cover.

Check the oil through for a smooth operation without binding.

Install the lifter rod.

Install the dowel pins and a new gasket.

Install the right crankcase cover

Connect the clutch cable.

Install the exhaust muffler and step bar.

Fill the crankcase with the recommended oil

Adjust the clutch lever free play.

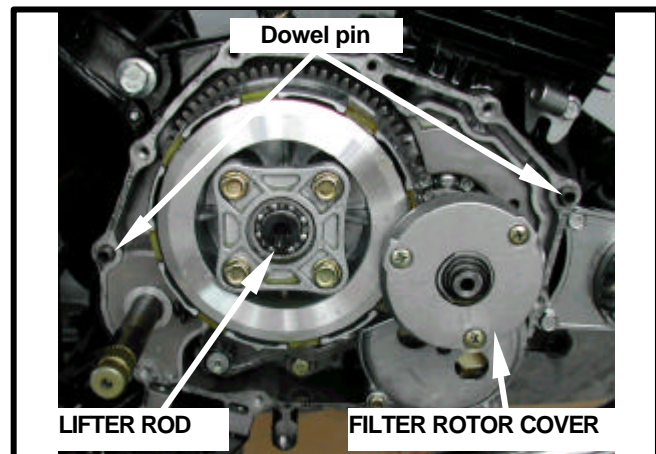

OIL PUMP

OIL PUMP REMOVAL

Remove the right crankcase cover.
Remove the oil filter rotor.
Remove the oil pump cover.

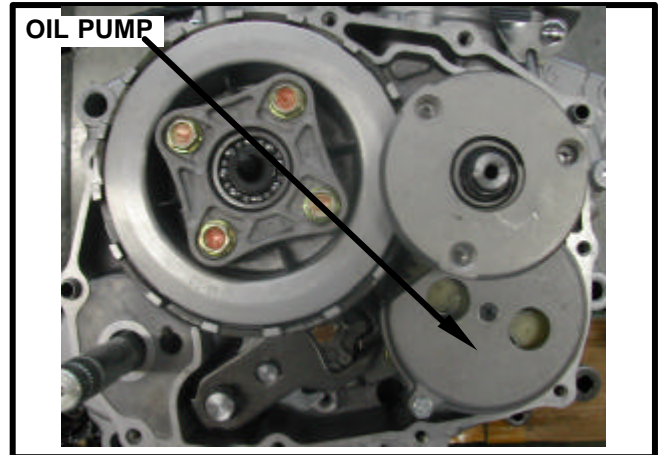

Remove the oil pump drive gear.
Remove the 6 mm screws and oil pump.

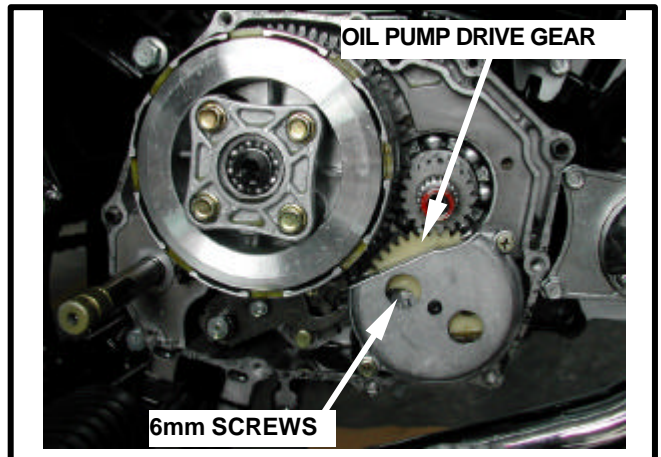

OIL PUMP DISASSEMBLY

Remove the oil pump plate.

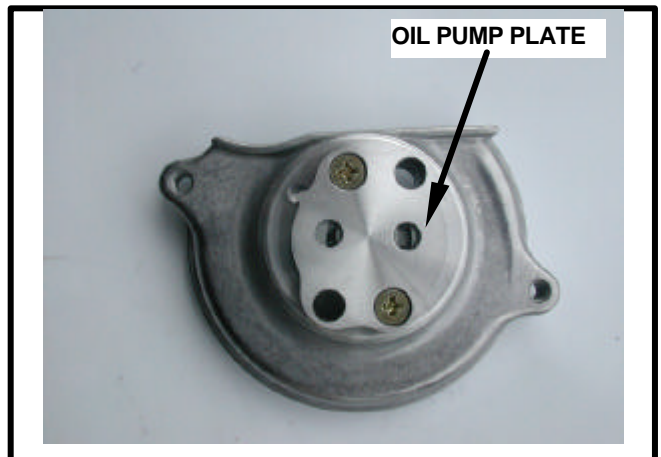

OIL PUMP INSPECTION

Measure the inner rotor-to-outer rotor clearance.
SERVICE LIMIT: 0.35mm

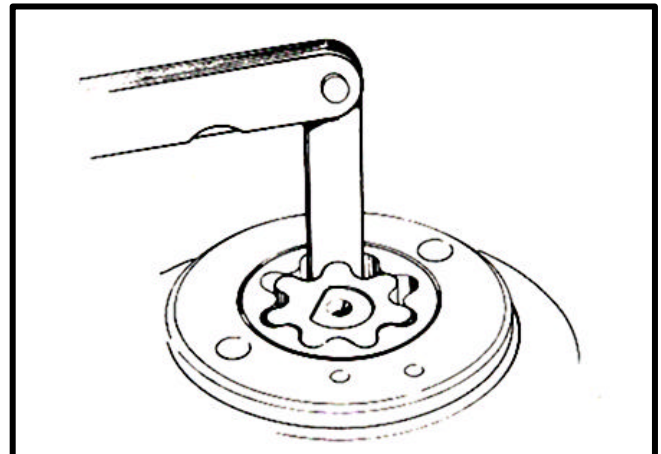

7. CLUTCH/OIL PUMP/GEAR SHIFT



Measure the outer rotor-to-body clearance.
Service limit: 0.40mm

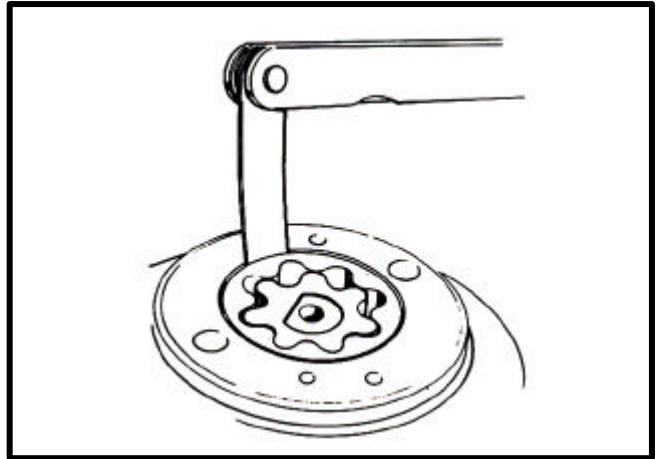

Measure the rotor-to-cover clearance.

NOTE:

Measure the clearance with the gasket installed.

Service limit: 0.11mm

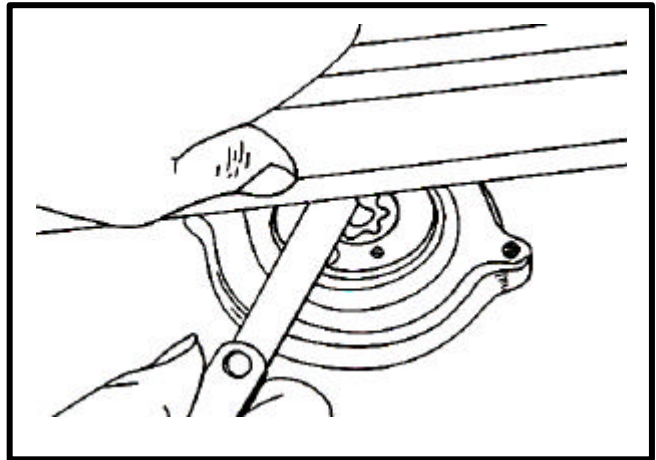

OIL PUMP ASSEMBLY

Install the oil pump drive gear and gear shaft on the pump body.
Install the oil pump cover.

NOTE:

Align the cutout in inner rotor with the cutout on the shaft.

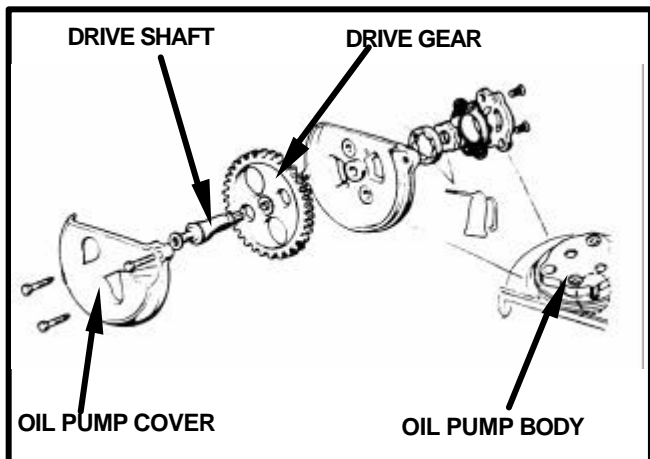

Check the oil pump for rotating freely.



OIL PUMP INSTALLATION

Install new O-rings.
Install the oil pump to the right crankcase.

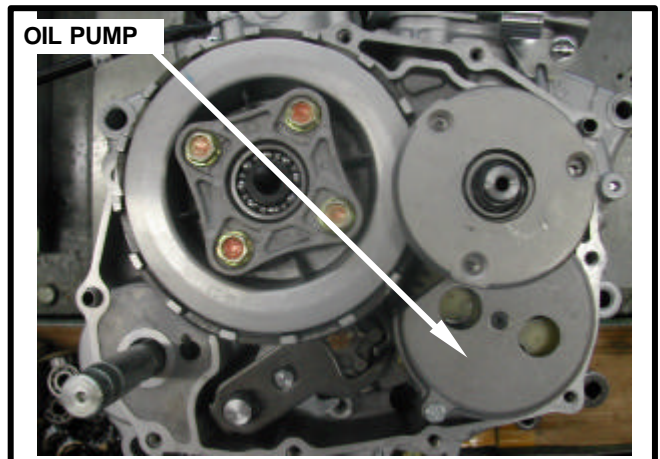
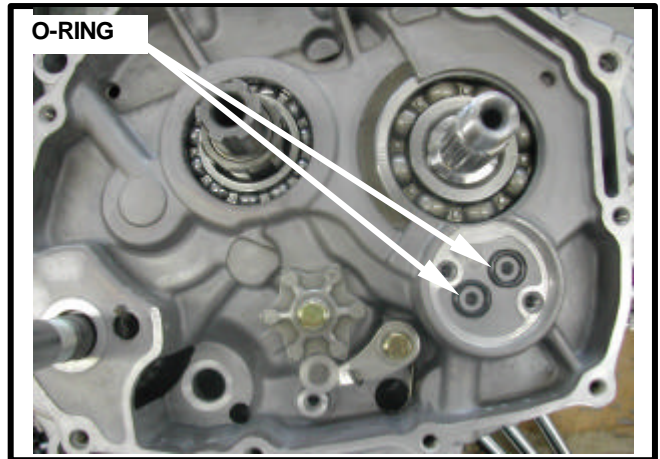
**GEARSHIFT LINKAGE****GEARSHIFT LINKAGE DISASSEMBLY**

Remove the clutch.
Remove the gearshift pedal.
Remove the gearshift spindle.

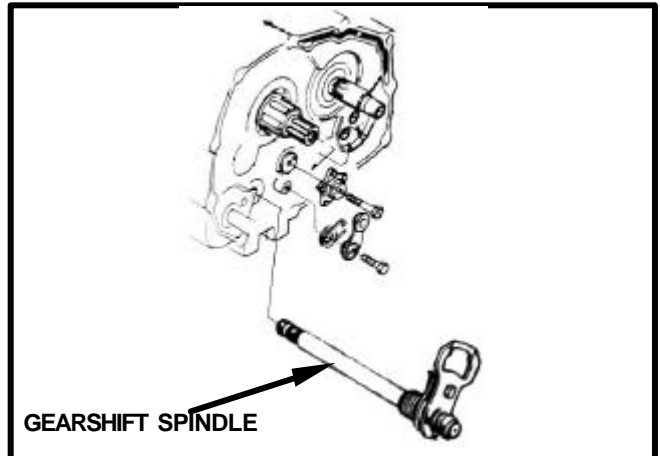

7. CLUTCH/OIL PUMP/GEAR SHIFT



Remove the gearshift drum stopper arm.
Remove the gearshift cam.
Check each part for wear or damage.

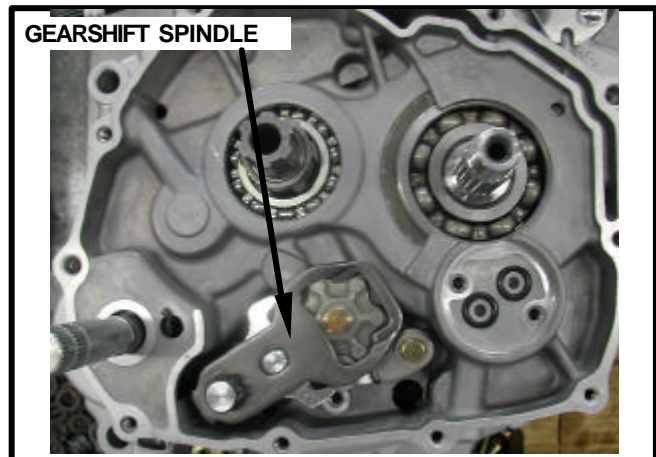
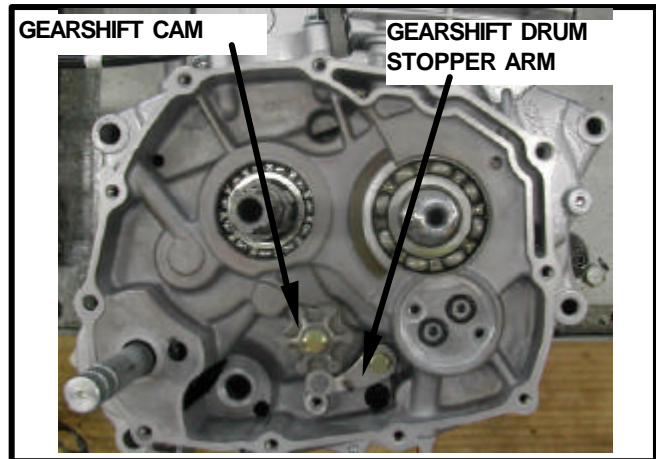

GEARSHIFT LINKAGE ASSEMBLY

Install the four 4mm roller.
Align the hole of the gearshift cam with the roller, then install the gearshift cam.

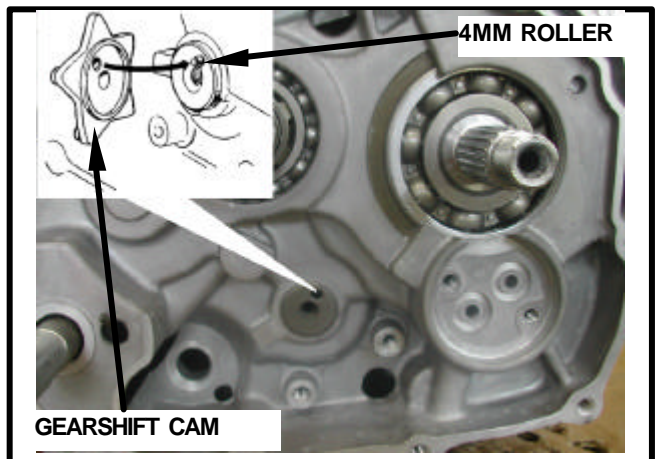

Install the gearshift drum stopper.

NOTE

After installation, check the drum stopper operation.

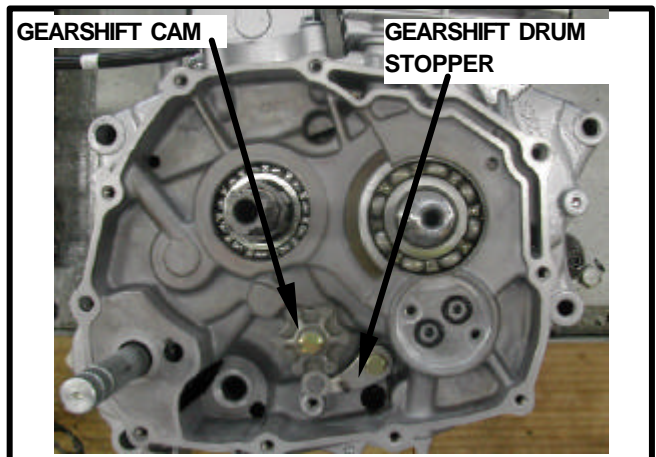

Install the gearshift spindle.

NOTE :

Align the gearshift return spring on the projection of the crankcase.

Check the gearshift linkage for smooth operation.
Install the clutch, oil pump and oil filter rotor.

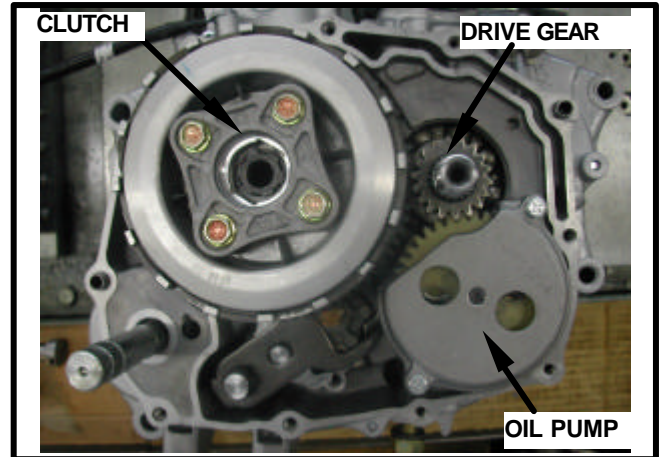
**RIGHT CRANKCASE COVER INSTALLATION**

Install the dowel pins and a new gasket.
Install the right crankcase cover and tighten the screws.
Connect the clutch cable.
Install the kick starter pedal.
Fill the crankcase with the recommended oil.
Adjust the clutch lever free play.



SERVIE INFORMATION8-1	LEFT CRANKCASE COVER INSTALLATION8-3
LEFT CRANKCASE COVER REMOVAL.....8-2	STARTER MOTOR REMOVAL8-4
FLYWHEEL REMOVAL.....8-2	STARTER DRIVEN GEAR REMOVAL8-4
FLYWHEEL INSTALLATION8-3	STARTER MOTOR GEAR SET8-4

SERVIE INFORMATION

GENERAL INSTRUCTION

This section covers removal and installation of the AC generator and starter motor.

These operation can be done with the engine installed in the frame.

Special tool

Rotor puller

TORQUE VALVE

Flywheel bolt

260~320kgf.cm

8. A.C.GENERATOR



LEFT CRANKCASE COVER REMOVAL

Remove the gearshift pedal.
Remove the left crankcase rear cover.
Disconnect the AC generator and pulse generator wire connector.
Remove the left crankcase cover.

NOTE:

Generator stator is in the left crankcase cover, it can be removed by removing the attaching screws.

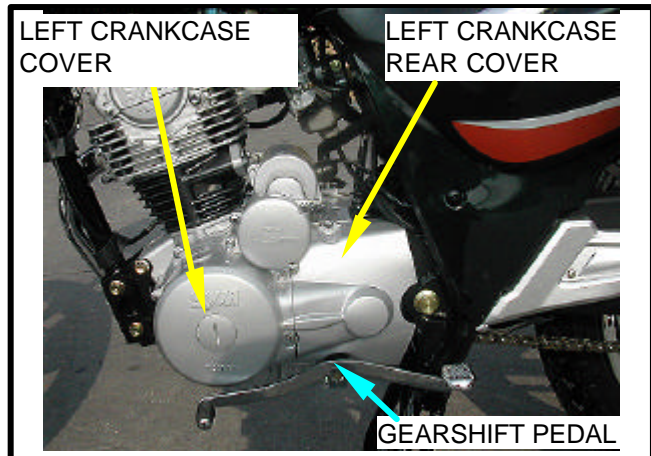

FLYWHEEL REMOVAL

Remove the flywheel bolt.

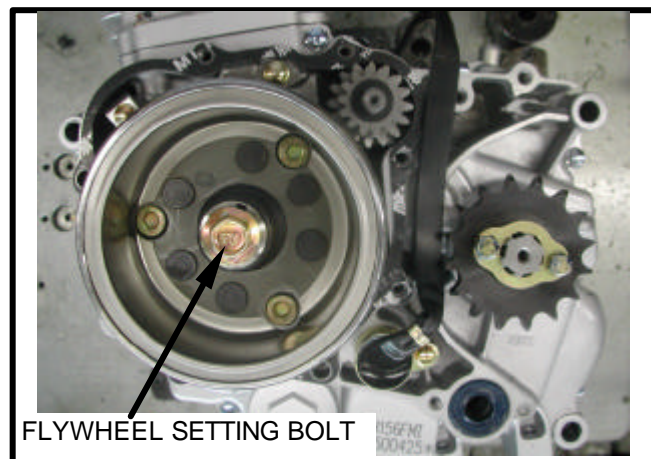

Remove the flywheel with the rotor puller.

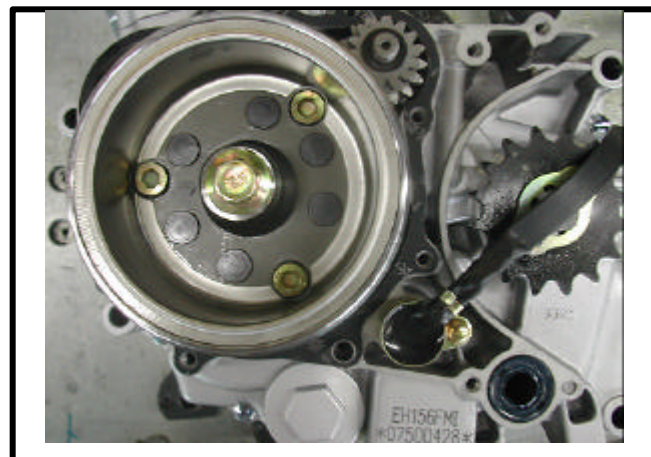

STATOR COIL INSPECTION

NOTE :

This inspection can be made with the stator in the frame.

Check the starter for continuity.

Continuity should exist between:

Yellow and pink,

Black/red and ground,

Blue/white and green/white

Pink,yellow,blue/white and green/white should not continue with the ground.

Yellow and green.

Replace the stator and pulse generator assembly if necessary.



FLYWHEEL INSTALLATION

Reverse the procedure of removal to assembly.

NOTE :

- Check wire for security in its place.
- Do not interfere the wire with the flywheel.

Install and tighten the flywheel.

TORQUE: 400~500 kgf. cm

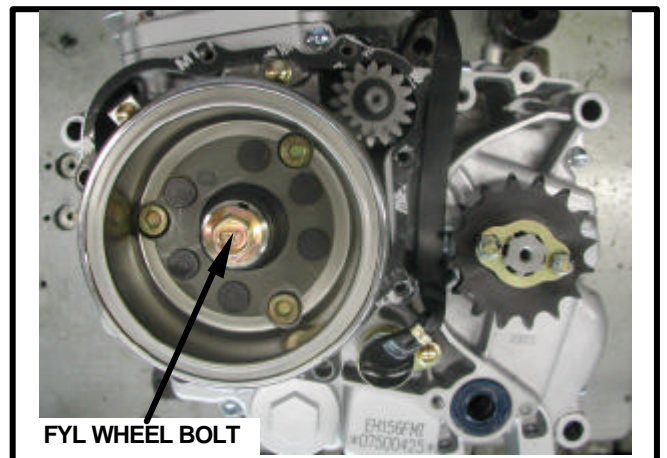

FYL WHEEL BOLT

LEFT CRANKCASE COVER INSTALLATION

Install the left crankcase cover (with stator coil)

Connect the generator wire connectors.

Route the neutral switch wire through the groove in the left crankcase cover.

Install the left crankcase rear cover.

Install the gearshift pedal.

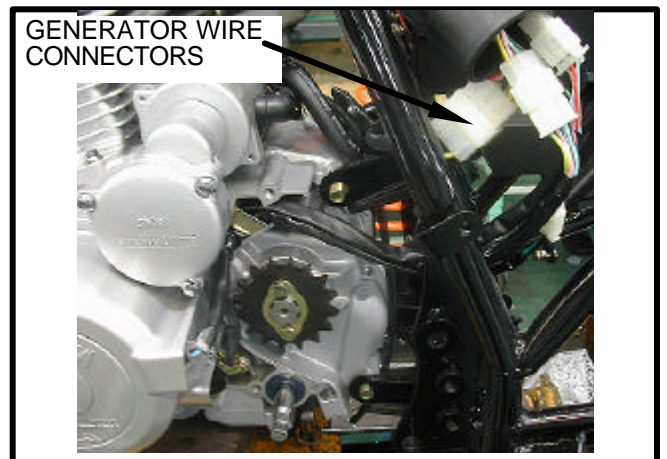

GENERATOR WIRE CONNECTORS

STARTER MOTOR REMOVAL

Disconnect the starter motor wire from the motor..
Remove the starter motor by removing the bolts.

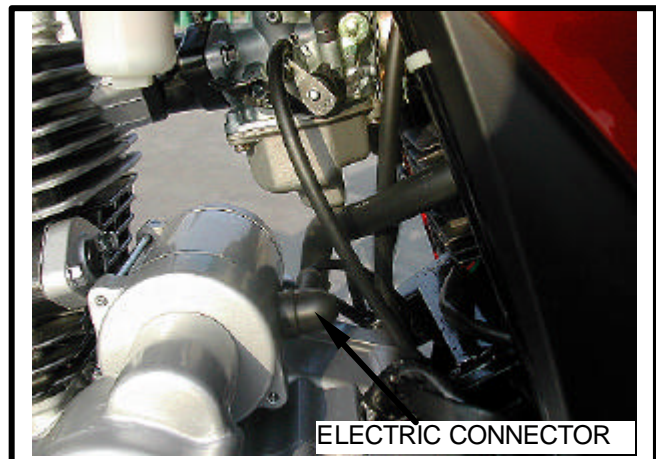
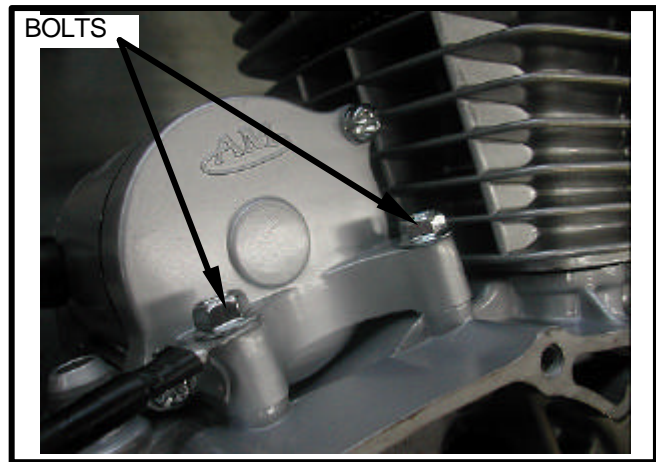

STARTER DRIVEN GEAR REMOVAL

Remove the left crankcase cover .
Remove the flywheel.
Remove the starter driven gear.

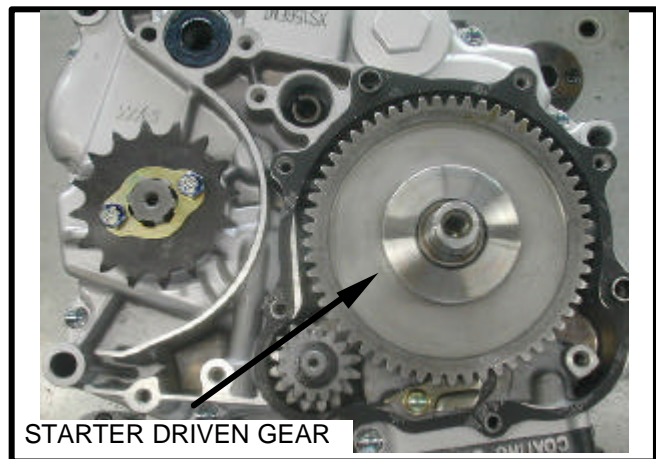

STARTER MOTOR GEAR SET

1. Starter driven gear
- 2 Starter reduce gear
- 3 Starter motor

Install the starter motor and gear in the reverse order of removal.

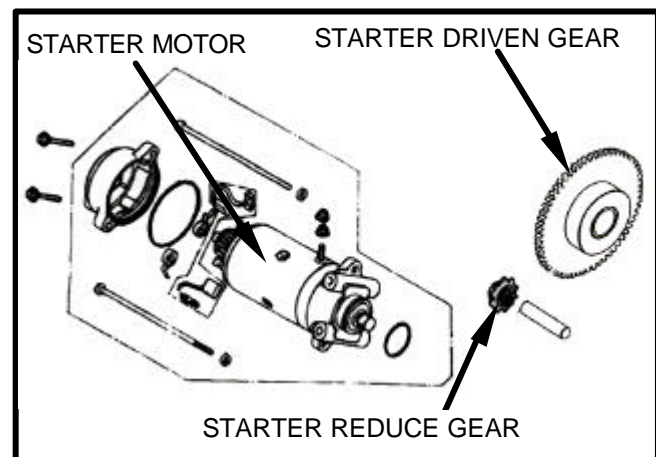

TROUBLE SHOOTING9-1 SERVICE INFORMATION.....9-2 CRANKCASE SEPARATION9-2 CRANKSHAFT REMOVAL9-3	TRANSMISSION DISASSEMBLY.....9-5 TRANSMISSION ASSEMBLY.....9-8 KICK STARTER DISASSEMBLY9-10 CRANKCASE ASSEMBLY.....9-11
--	--

TROUBLE SHOOTING

HARD TO SHIFT

1. Shift fork bent
2. Shift fork shaft bent

TRANSMISSION JUMPS OUT OF GEAR

1. Gear dogs worn
2. Shift fork bent or damaged
3. Shift fork shaft bent

CRANKSHAFT NOISE

1. Worn connecting rod big end bearing
2. Bent connecting rod
3. Worn crankshaft bearing

GEAR NOISE

1. Worn transmission gears
2. Worn spline shafts

SERVICE INFORMATION

GENERAL INSTRUCTION

Transmission and crankshaft repairs require crankcase separation.

Remove the following parts before separating the crankcase:

Engine removal	4-2
Cylinder head removal	5-2
Cylinder / Piston removal	6-2
Clutch / oil pump / Gearshift linkage removal	7-2
Left crankcase cover removal	8-2
Flywheel removal	8-2

SPECIAL TOOLS

- Bearing driver
- Bearing driver pilot

SPECIFICATIONS

ITEM		STANDARD SERVICE	LIMIT	
Gearshift fork	I.D.	12.000 ~ 12.018mm	12.05mm	
	Claw thickness	4.925 ~ 5.000mm	4.80mm	
Shift fork shaft	O.D.	11.976 ~ 11.994mm	11.9mm	
Crankshaft	Runout	0.030mm below	0.050mm	
	Connecting rod small End I.D.	15.016 ~ 15.034mm	15.08mm	
	Connecting rod big End side clearance	Axial	0.10 ~ 0.30mm	0.6mm
		radial	0.000 ~ 0.008mm	0.030mm

CRANKCASE SEPARATION

Remove the right crankcover and internal parts.
(7-3~ 7-13)

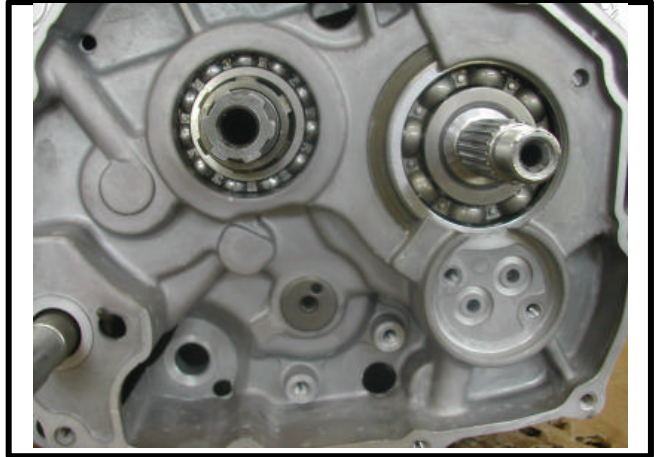

Remove left cover and internal parts.

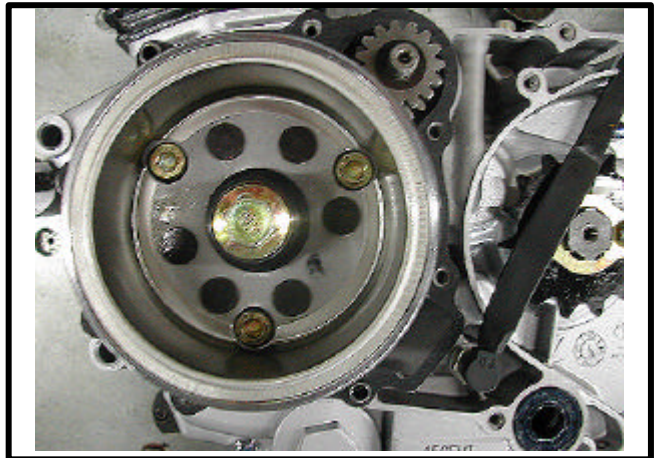

Remove the left crankcover all 6mm attaching bolts.
Separate the left crankcase from the right crankcase.
Remove the gasket and dowel pins.



CRANKSHAFT REMOVAL

Remove the left crankcase.
Remove the crankshaft.

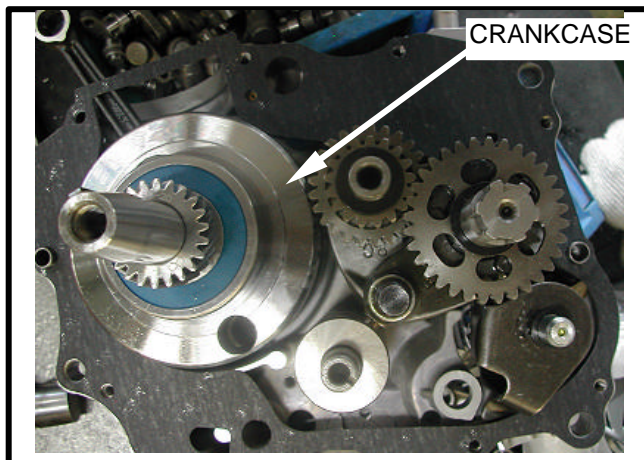

CRANKSHAFT INSPECTION

Measure the connecting rod big end side clearance
with a feeler gauge.
Service limit: 0.60mm

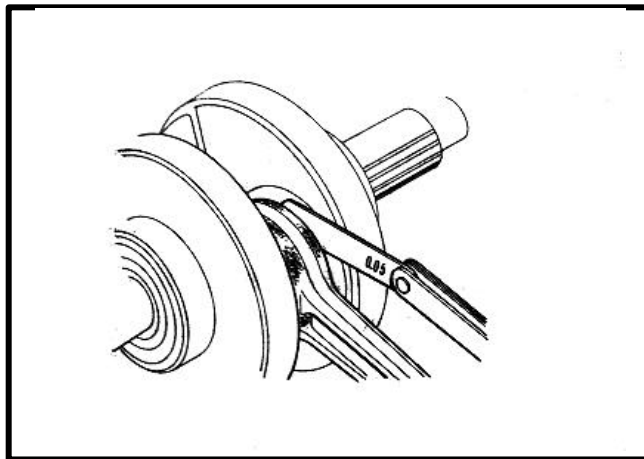

Measure the connecting rod big end radial clearance.
Service limit:0.05mm

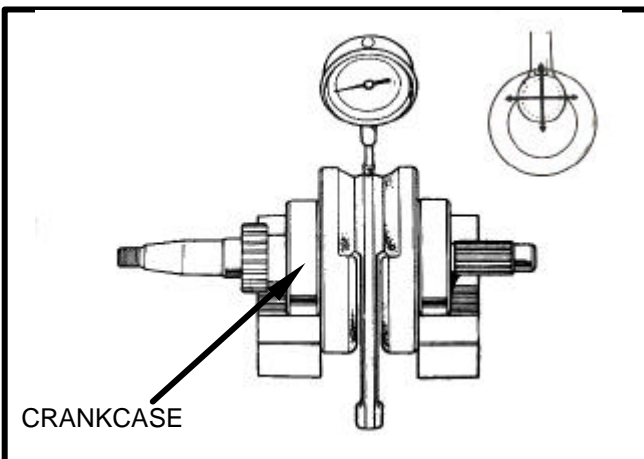

Support the crankshaft bearings on a V-block and measure the runout using a gauge.

NOTE:

Coat the bearing and connecting rod big end with engine oil before installation.

Service limit: 0.050mm

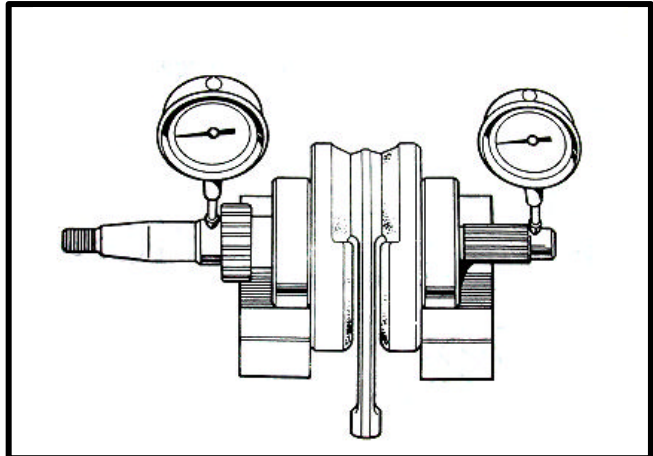

Measure the connecting rod small end I.D.
Connecting rod small end I.D.
Service limit: 15.08mm

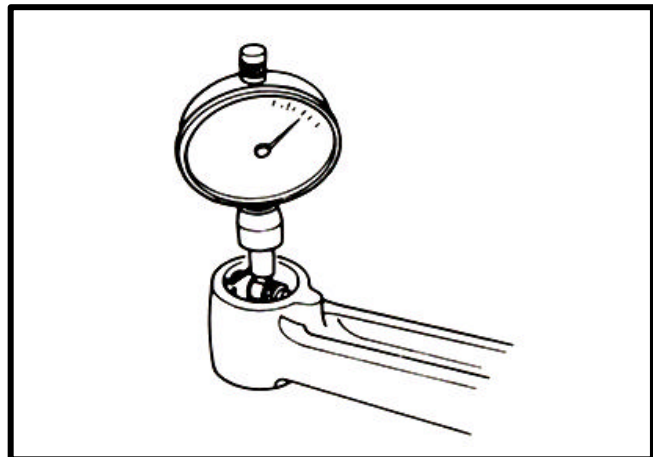

CRANKSHAFT BEARING INSPECTION

Spin the crankshaft bearing by hand and check for play. The bearing must be replaced if it is noisy or has excessive play.

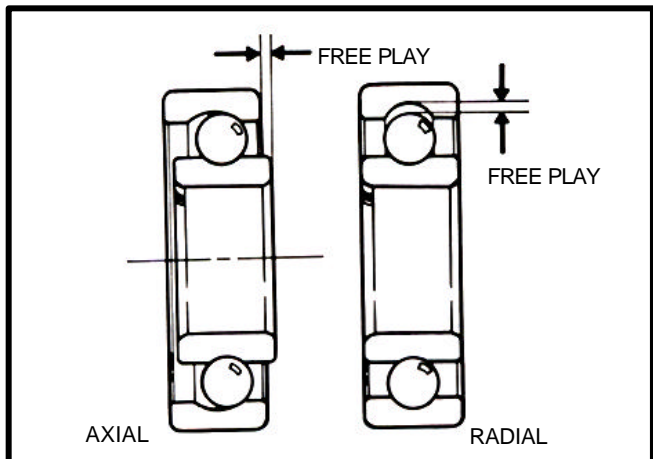

TRANSMISSION DISASSEMBLY

Remove the crankshaft.
Remove the shift fork shaft.
Remove the shift drum.
Remove the shift forks.

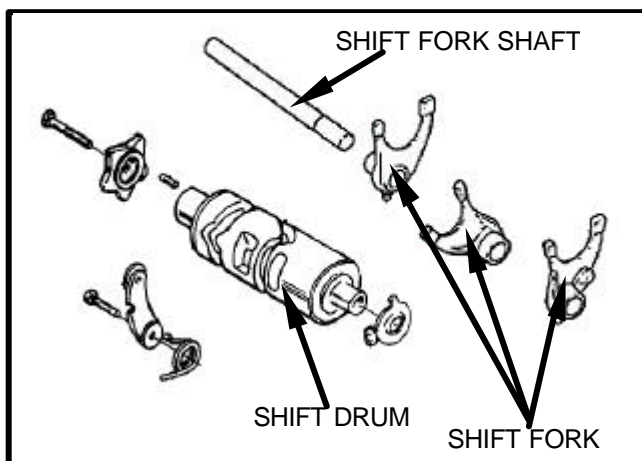
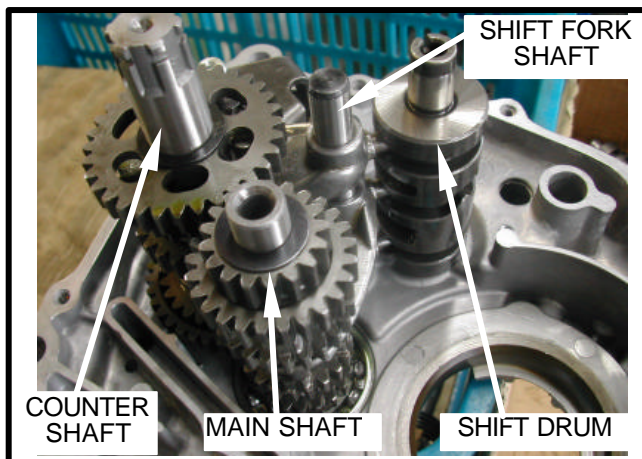

SHIFT FORK AND SHIFT FORK SHAFT INSPECTION

Check the shift fork for wear, bending or damage.
Measure the shift fork I.D.
Service limit: 12.05mm

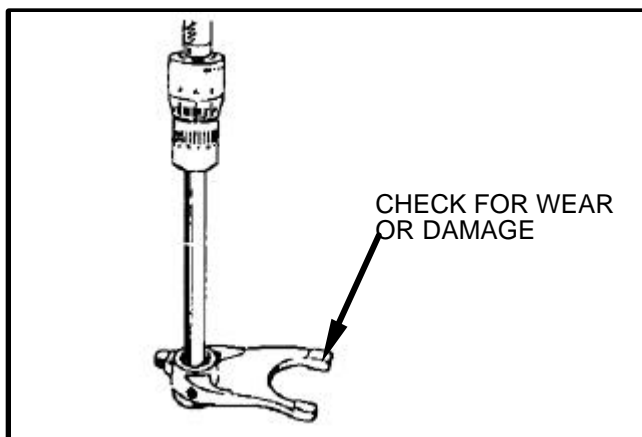

Measure each shift fork claw thickness.
Service limit: 4.80mm

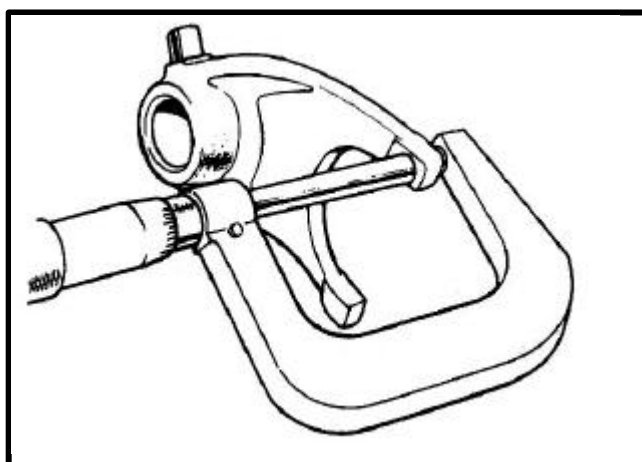

Measure the shift fork shaft O.D.
Service limit: 11.976mm

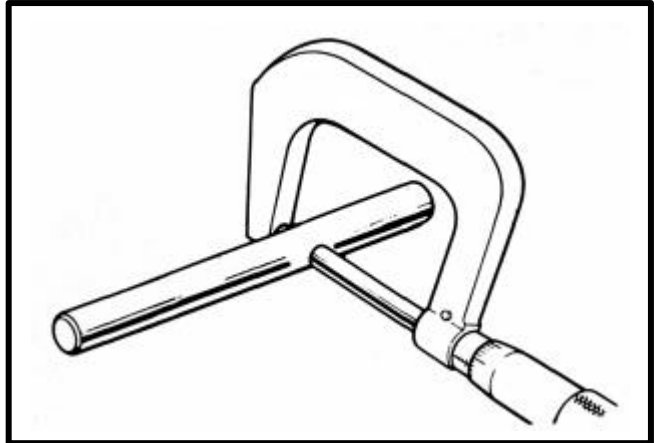

SHIFT DRUM INSPECTION

Check the gearshift drum for wear or damage.



Disassemble the transmission gears.
Check each gear for wear or damage and replace if necessary.

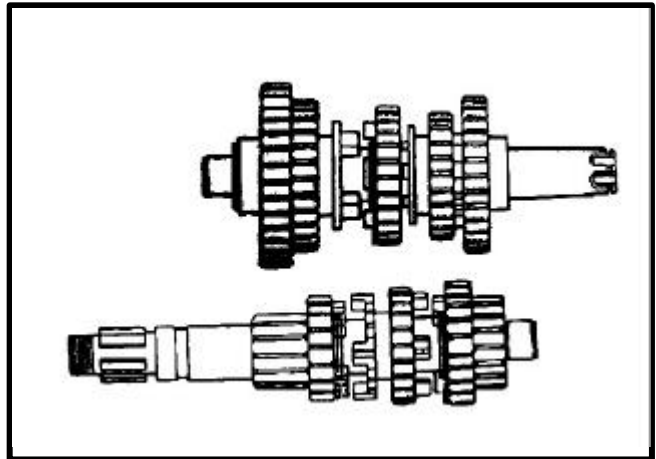

Check the crankcase oil orifice for clogged, blowing through with compressing air if necessary.

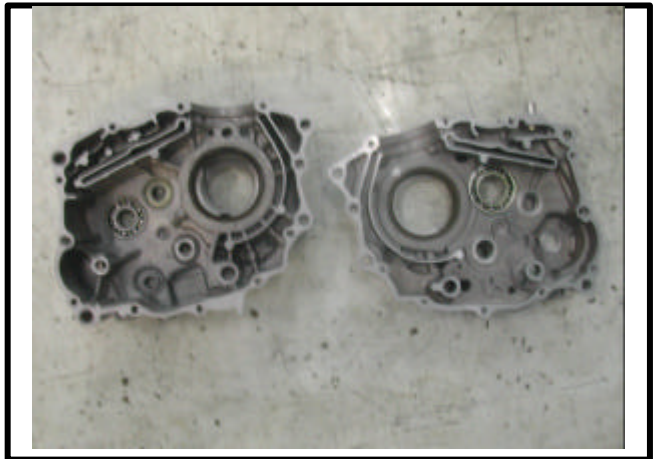

Check the crankcase bearings, replace them if they have excessive free play or noisy.

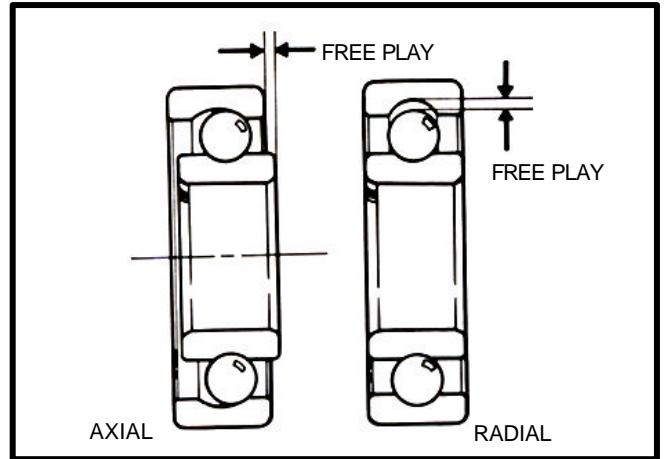

BEARING INSTALLATION

Install the bearings into the left, right crankcase with special tools.

NOTE:

Install the bearing horizontally, to prevent bearing damage.

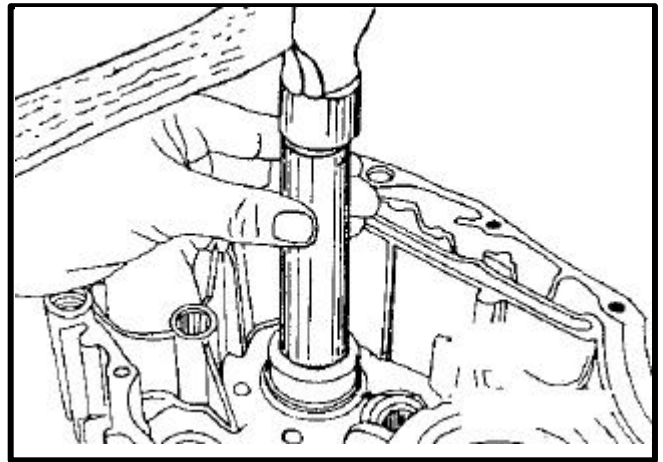

TRANSMISSION ASSEMBLY

NOTE:

Before assembling, coat each gears with engine oil.

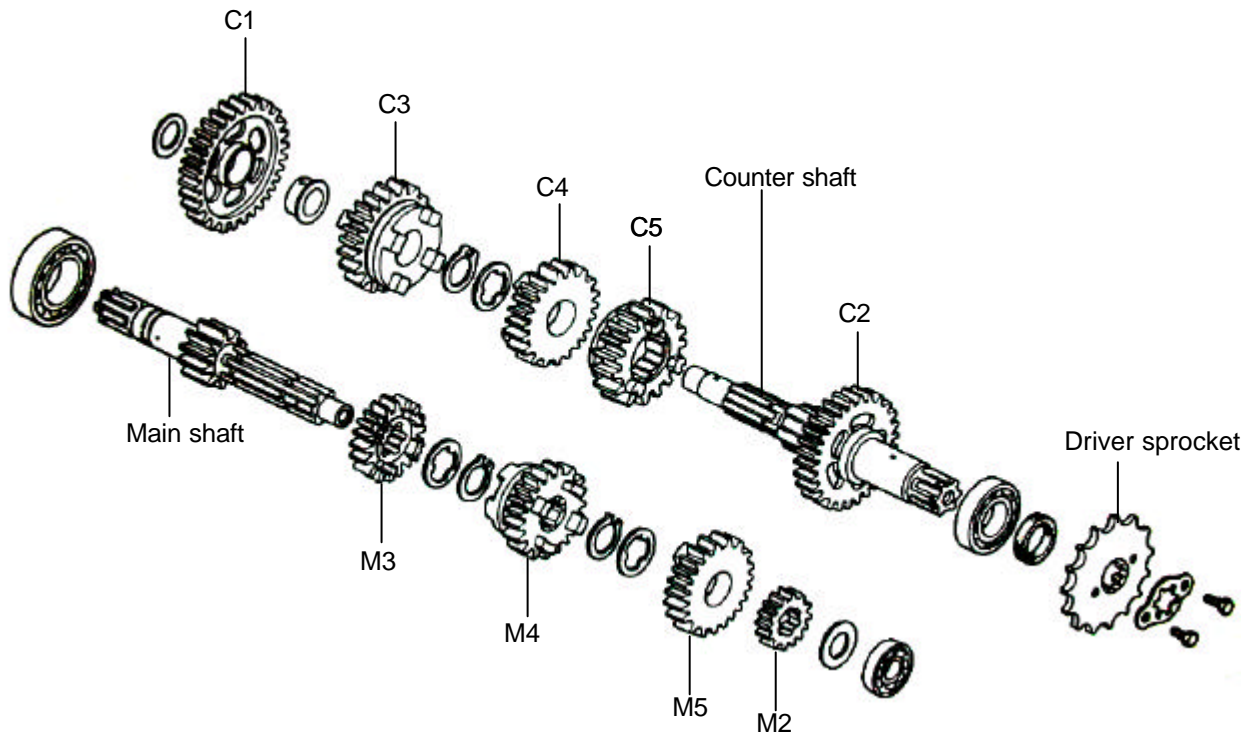

Assemble the gears of the countershaft and mainshaft.

NOTE:

Seat the snap ring in the ring groove properly.

Install the crankshaft assemblies in the right crankcase.

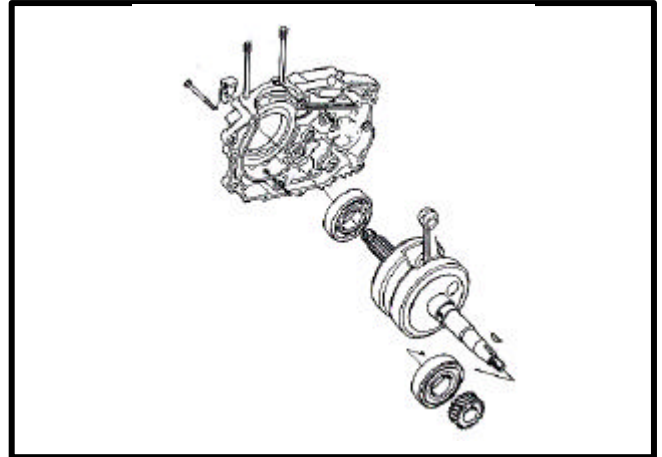

Install the mainshaft and countershaft assemblies in the right crankcase.

NOTE:

Keep the thrust washers in place during installation.

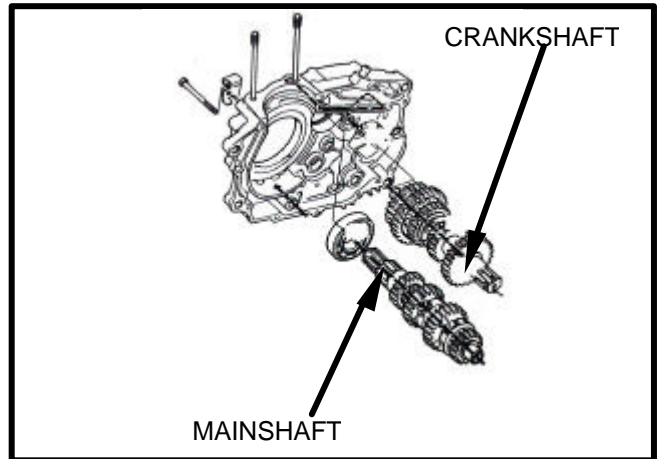

Install the mainshaft, countershaft and shift forks.

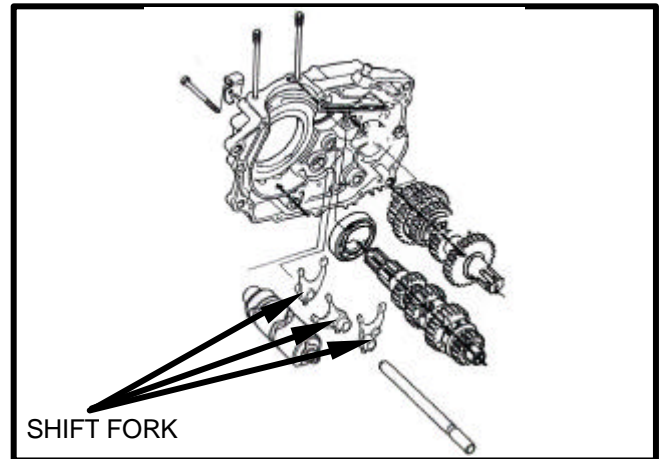

Install the gearshift drum.
Install the shift fork shaft.

NOTE:

Engage the shift fork guide pin with the drum groove by raising the shift fork.
After assembling, check each part for moving freely.

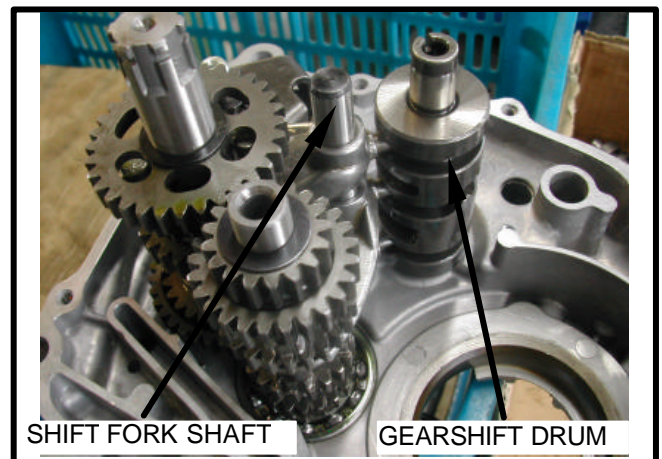

KICK STARTER DISASSEMBLY

Remove the kick starter spindle assembly.

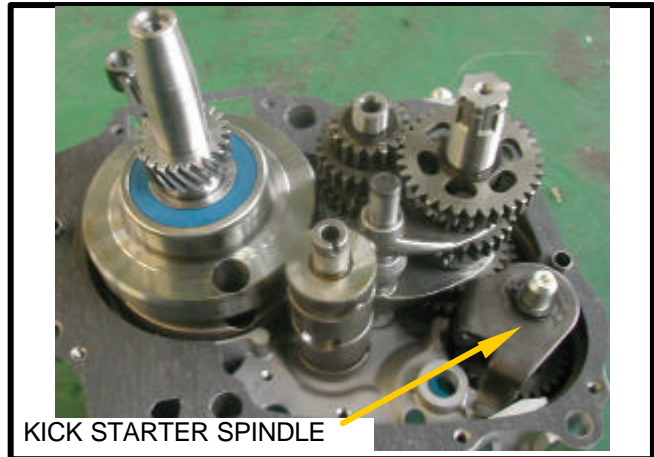

Remove the kick starter spindle from the engine.
Remove the thrust washer and drive ratchet.



Measure the I.D. of the pinion.
Service limit:24.96mm

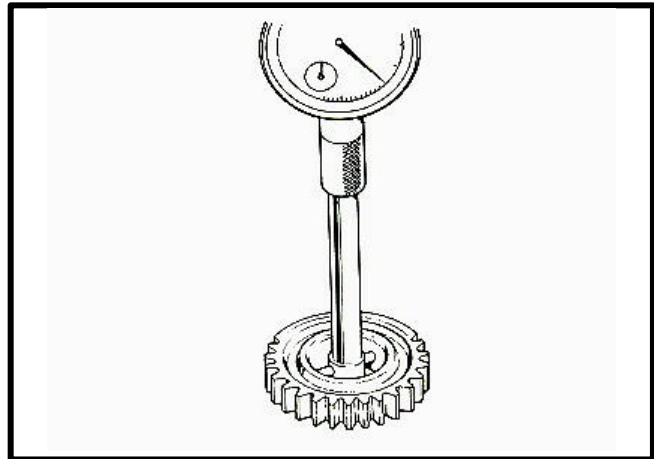

Measure the pinion sliding O.D. of the spindle.
Service limit:24.80mm



KICK STARTER ASSEMBLY

Reverse the operation of disassembly for assembling.



CRANK CASE ASSEMBLY

Install the gasket and dowel pins.
Install the left crankcase on the right crankcase.

NOTE:

Make sure that the gasket is in place.

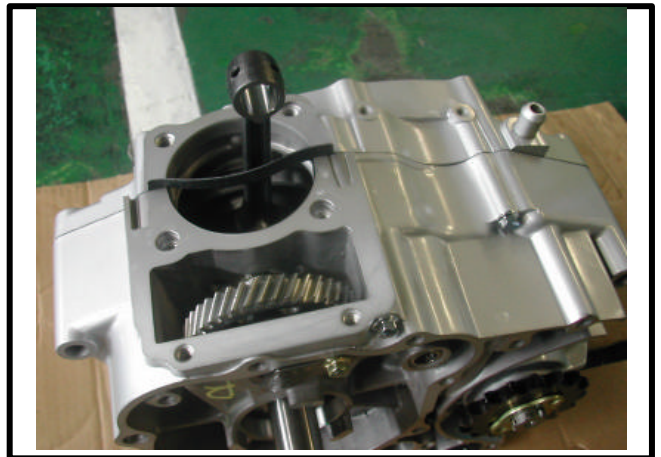

<p> TROUBLE SHOOTING10-1 SERVICE INFORMATION.....10-1 CARBURETOR REMOVAL.....10-2 THROTTLE VALVE DISASSEMBLY...10-2 FLOAT/FLOAT VALVE/JETS DISASSEMBLY 10-3 </p>	<p> FLOAT/FLOAT VALVE/JETS ASSEMBLY10-5 FLOAT/LEVEL ADJUSTMENT10-5 THROTTLE VALVE ASSEMBLY.....10-5 CARBURETOR INSTALLATION10-6 </p>
---	---

TROUBLE HOOTING

ENGINE CRANKS BUT NOT START

1. No fuel in the fuel tank
2. No fuel in the carburetor
3. Too much fuel in the combustion chamber
4. No spark at the spark plug (ignition malfunction)
5. Air cleaner clogged

ENGINE IDLE ROUGHLY

1. Idling speed incorrect
2. Ignition malfunction
3. Low compression
4. Rich mixture
5. Lean mixture
6. Air cleaner clogged

7. Air leaking into intake pipe
8. Fuel contaminated

LEAN MIXTURE

1. Carburetor jets clogged
2. Float chamber vent clogged
3. Fuel filter clogged
4. Fuel line restricted
5. Float level too low
6. Float valve faulty

RICH MIXTURE

1. Choke stuck closed
2. Float valve faulty
3. Float level too high

SERVICE INFORMATION

GENERAL INSTRUCTIONS

Take cautions when dealing this operation.
 Always work in a well-ventilated area and away from sparks or open flames. When assembling, note the

locations of the jets and place them individually.

SPECIAL TOOL

Float gauge

CARBURETOR REMOVAL

Disconnect the fuel line.
Disconnect the all connect tubes.
Drain fuel from the carburetor.

WARNING:

Keep away from flames or sparks. Wipe up spilled gasoline at once.

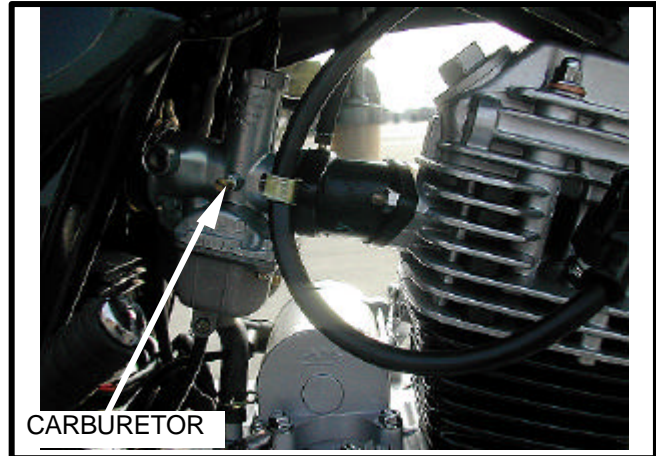

Loosen the carburetor band.

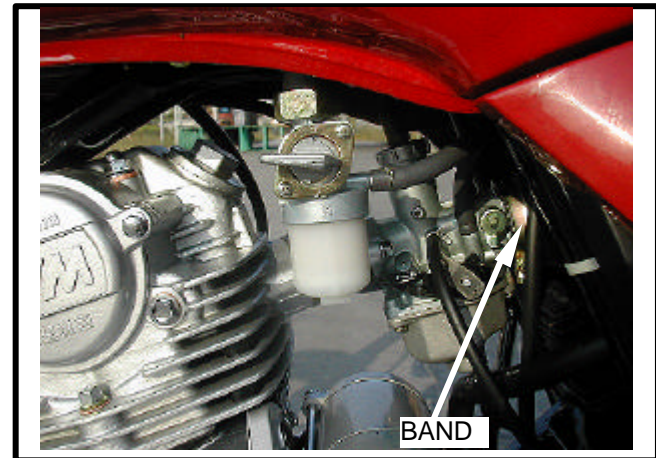

THROTTLE VALVE DISASSEMBLY

Disconnect the throttle cable.
Remove the needle spring.
Remove the needle.
Check the needle and throttle valve for wear or damage.

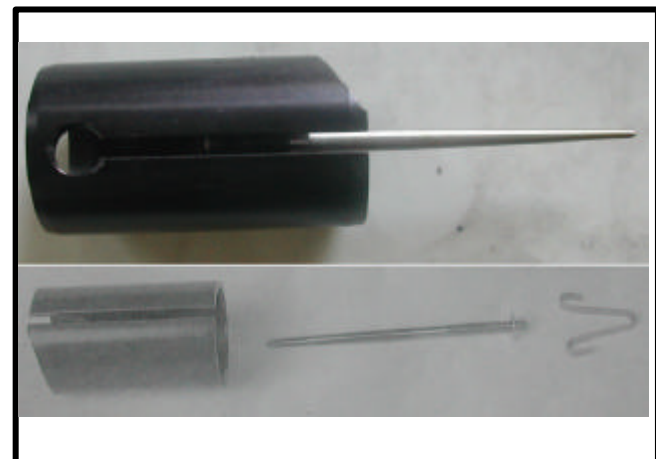
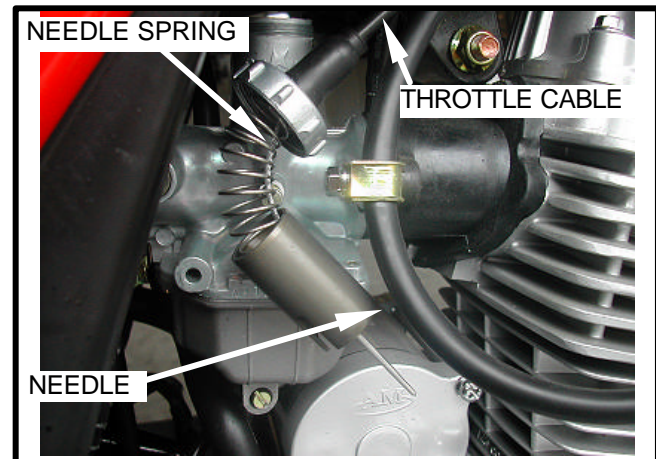

Remove the carburetor assembly.

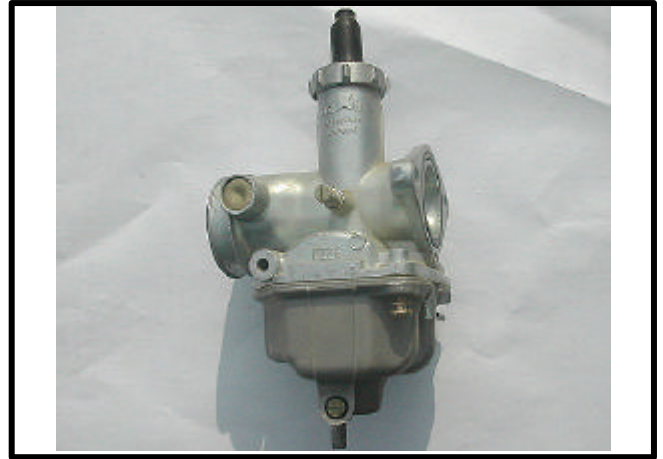

FLOAT/FLOAT VALVE/JETS DISASSEMBLE

Remove the float chamber body.

WARNING:

Pour the float chamber gasoline into the tank

Pull out the float pin, remove the float and float valve.

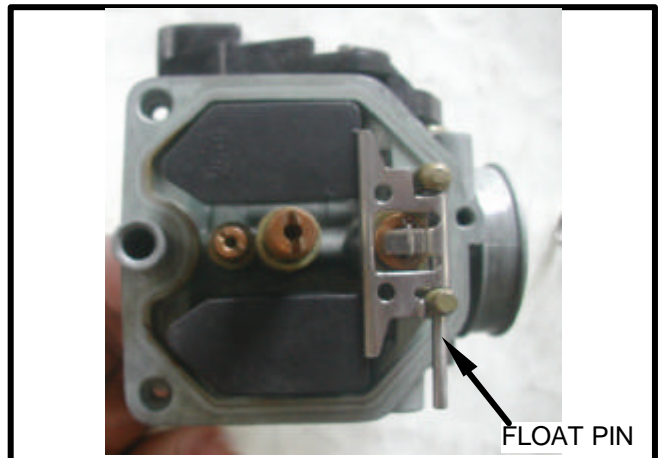

FLOAT VALVE INSPECTION

inspect the float valve surface for wear or damage.

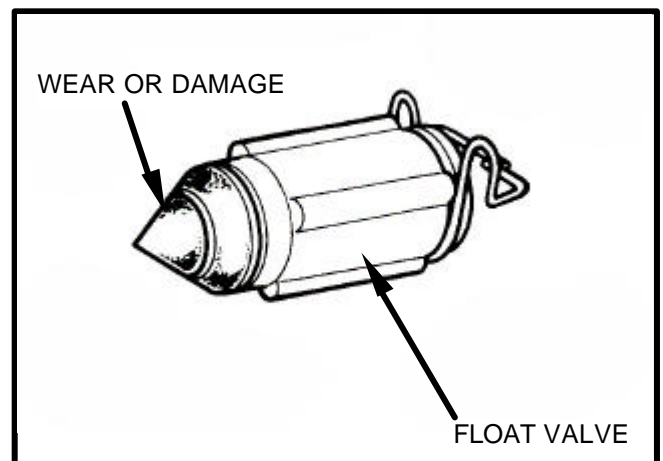

10. CARBURETOR



Remove the main jet, needle jet and needle jet holder.

NOTE:

Avoid damage to the jets.

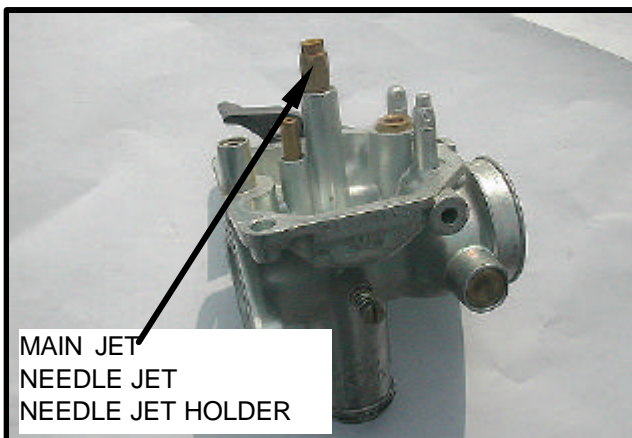

Remove the air screw.

NOTE:

Before removeing air screw, record the number of relations until it rests lightly so it can be returned to its original position.

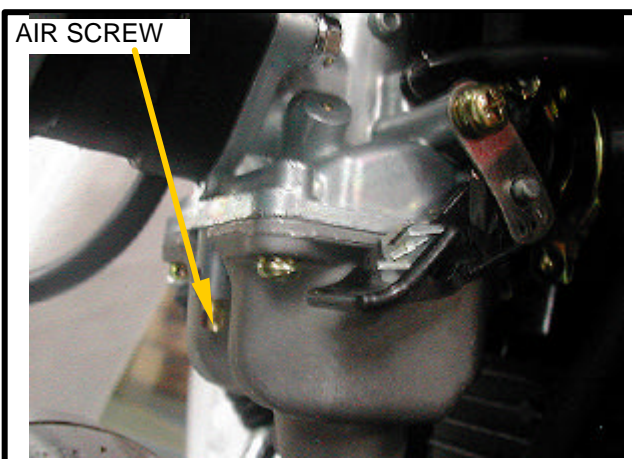

Check each part for damage.

Blow open all body openings with compressed air.

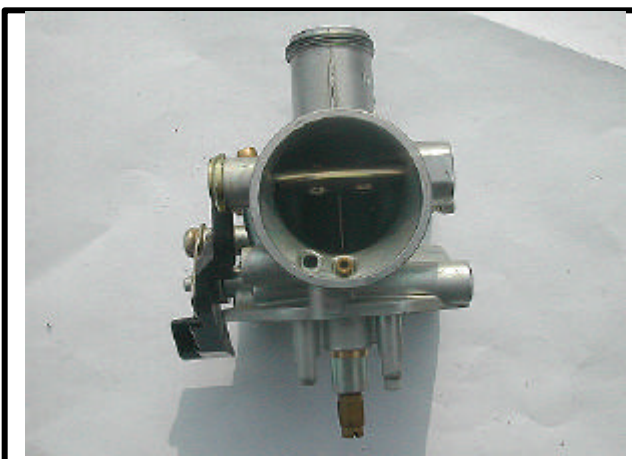

FLOAT/FLOAT VALVE/ JETS ASSEMBLY

Install the stop screw, air screw, main jet, needle jet and needle jet holder.

NOTE:

Do not damage jets at the time of assembly.

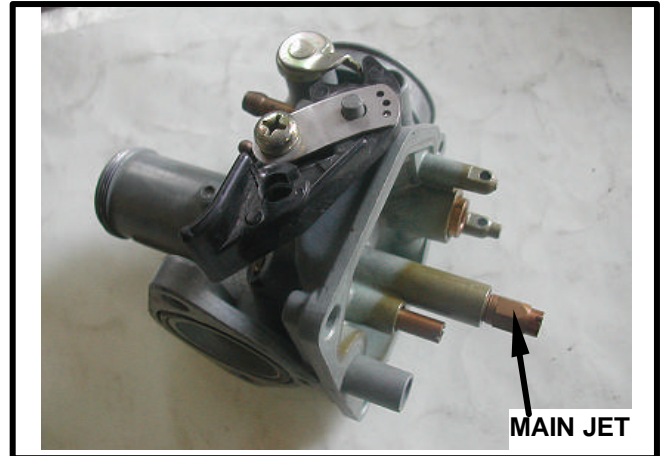

FLOAT LEVEL ADJUSTMENT

If the float level is too high or too low, bend the float arm for adjusting.

Float level: 24mm

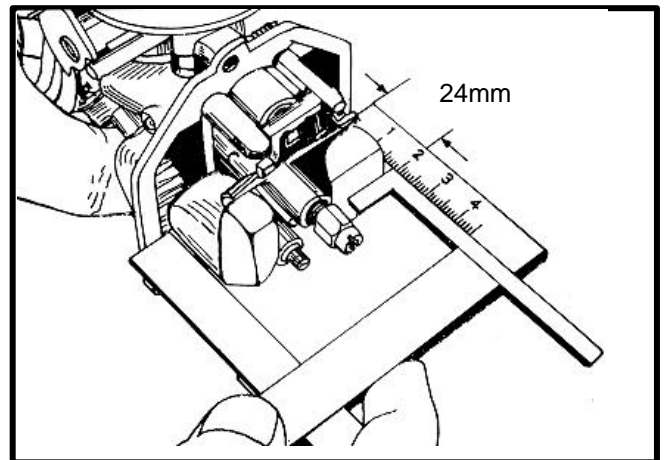

THROTTLE VALVE ASSEMBLY

Install the jet needle in the valve and secure it with the clip retainer.

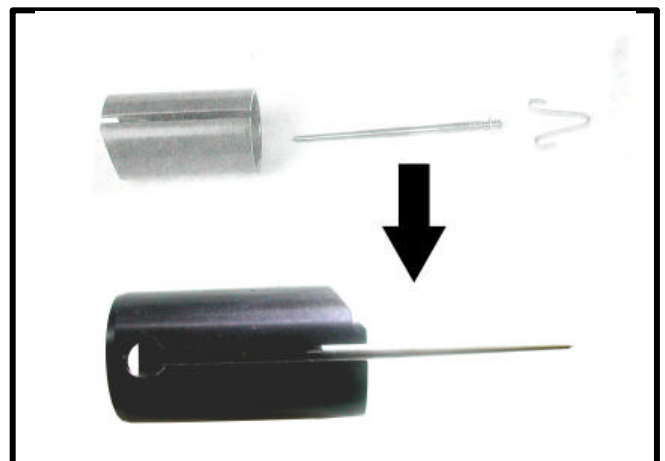

10. CARBURETOR



Connect the throttle cable.

NOTE:

Route the throttle cable end through the adjuster and the carburetor top. Make sure that the throttle cable is pulled tightly.

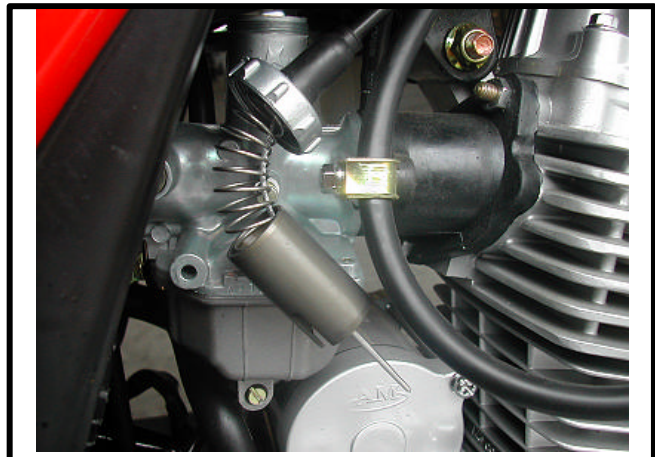
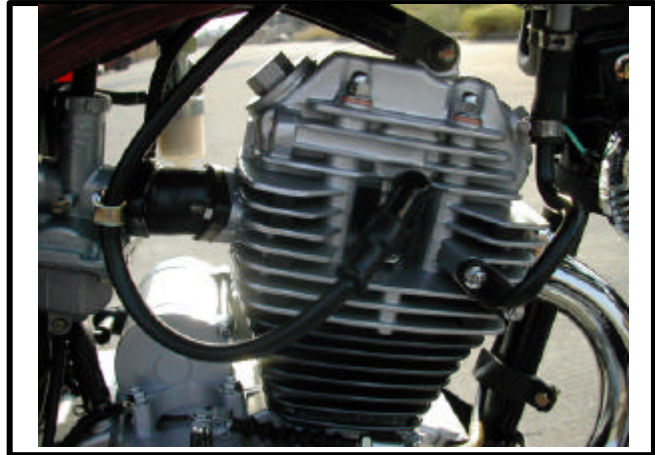

NOTE:

When installing the throttle valve, align the throttle valve groove with the pilot screw.

CARBURETOR INSTALLATION

Installation is essentially in the reverse order of removal.

After Installation, adjust:
Throttle grip free play (2-10).
Idling speed (2-11).

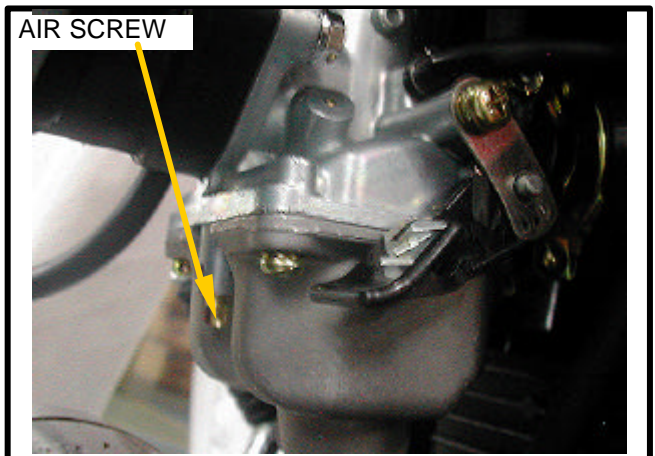
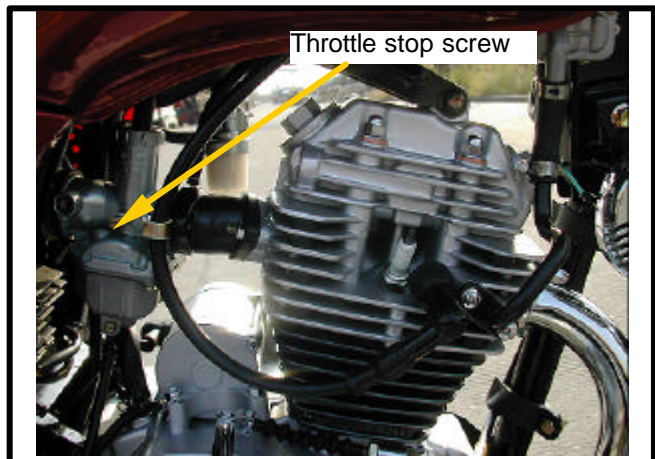

TROUBLE SHOOTING.....	11-1	HANDLE BAR.....	11-3
SERVICE INFORMATION.....	11-1	FRONT WHEEL.....	11-4
HEADLIGHT.....	11-2	FRONT FORK.....	11-7
METER.....	11-3	STEERING STEM.....	11-8

TROUBLE SHOOTING

FRONT WHEEL WOBBLING

1. Axle not tightened properly
2. Worn front wheel bearing
3. Distorted rim

HARD STEERING

1. Steering stem nut too tight
2. Faulty steering stem bearing
3. Insufficient tire pressure

STEERS TO ONE SIDE

1. Bent front axle
2. Bent front fork
3. Faulty front wheel
4. Misadjusted shock absorber

SOFT SUSPENSION

1. Weak rear fork spring
2. Insufficient fluid in the front forks

HARD SUSPENSION

1. Bent front fork
2. Too much fluid in the front forks

FRONT SUSPENSION NOISE

1. Bent front fork
2. Insufficient fluid in the front fork
3. Loose front fork fasteners

SERVICE INFORMATION

GENERAL INSTRUCTIONS

This section covers the removal, inspection and installation of the front wheel, front fork and steering. Before removing the front wheel, place a block under the engine.

TORQUE VALUES

Front wheel axle nut	600 ~ 800 kgf . cm
Handlebar upper holder	100 ~ 140 kgf . cm
Steering stem nut	600 ~ 800 kgf . cm
Front fork top bridge	400 ~ 550 kgf . cm
Front fork bottom bridge	400 ~ 550 kgf . cm

SPECIFICATIONS

		STANDARD SERVICE	LIMIT
Axle runout		2.0mm
Rim runout	Axial	2.0mm
	Radial	2.0mm

HEADLIGHT

HEADLIGHT REMOVAL

Remove the headlight screw.
Remove the headlight case.
Disconnect the wire connector.



HEADLIGHT WIRING

Route the wires through the headlight
Connect the wires Color-to-color.

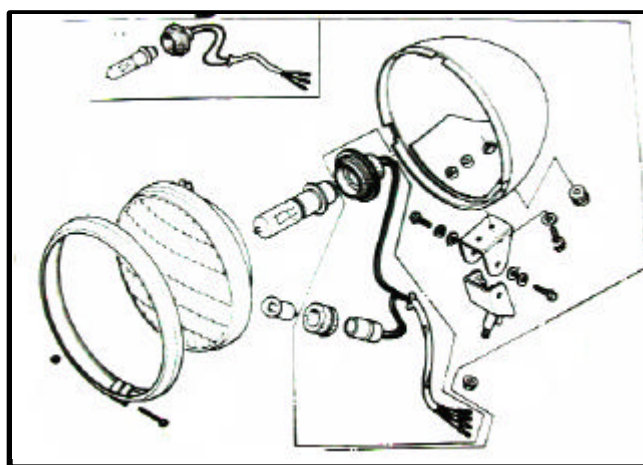

HEADLIGHT INSTALLATION

Install the headlight.
Install the headlight case aligning the mark to the
holder, tighten the bolts.

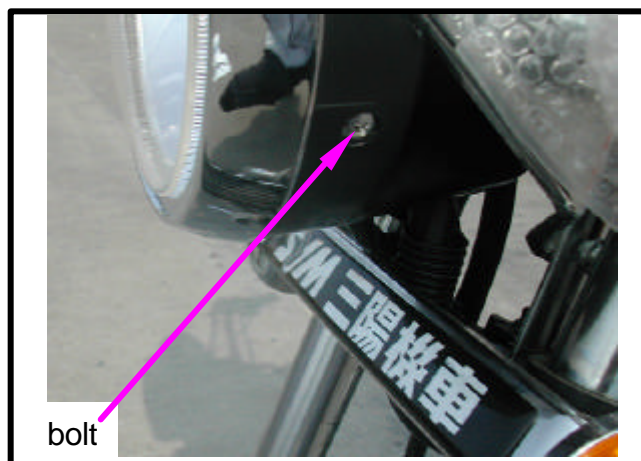

METER**METER REMOVAL**

Remove the headlight case .
Disconnect each wire and connector.
Disconnect the meter cables.
Remove the setting screws.
Remove the meter.

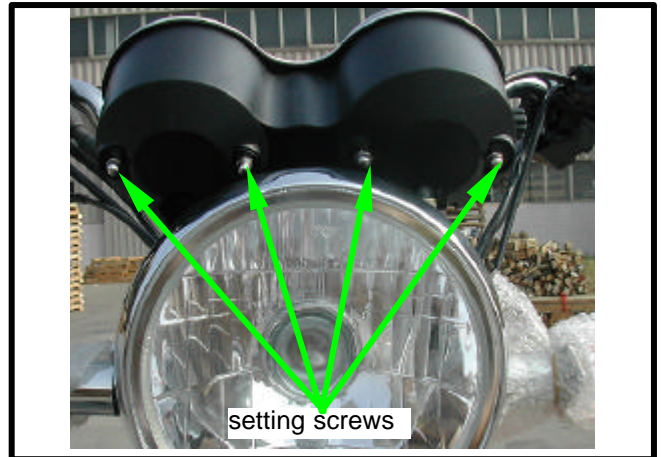
**HANDLEBAR****HANDLEBAR REMOVAL**

Remove the wire harness.
Remove the light switch and throttle cable, remove the turn signal switch assembly.
Remove the handlebar upper holder bolts.
Disconnect the front brake and clutch cable from the lever.
Remove the handlebar holders and take off the handlebar.

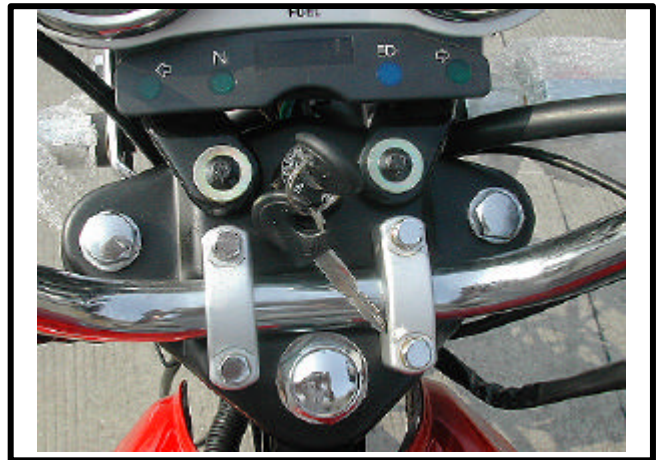
**HANDLE BAR INSTALLATION**

Connect the front brake and clutch cable to the lever.
Install the handlebar on the lower holder.

NOTE:

Align the punch marks on the handlebar with the top of the handlebar lower holder.

Install the handlebar holders.

NOTE:

Tighten the forward bolts to the specified torque first, then tighten the rear bolts to the same torque.

TORQUE:100~140 kg-m

Install the light switch and throttle grip.

NOTE:

Coat the throttle grip hole with grease.

Install the winker switch assembly.

NOTE:

Align the punch mark on the handlebar with the split in the housing.

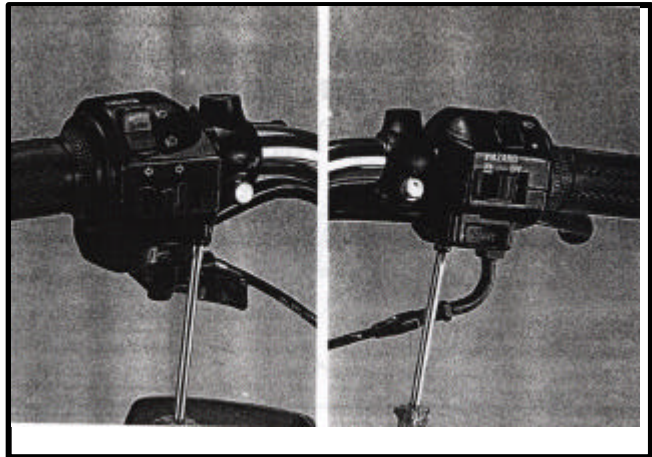

FRONT WHEEL

FRONT WHEEL REMOVAL

- Raise the front wheel off the ground by placing a block under the engine.
- Disconnect the speedometer cable and front brake cable.
- Remove the axle nut.
- Pull out the axle, remove the front wheel.



FRONT WHEEL AXLE SHAFT INSPECTION

- Place the axle on V-blocks and measure the runout, the actual runout is 1/2 of the total indicator reading.
- Service limit: 0.2mm under

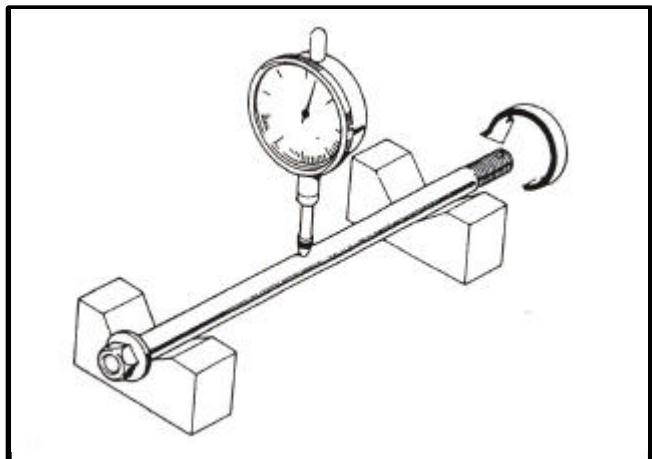

WHEEL BEARING INSPECTION

- Shake the bearing back and forth and spin it by hand, replace the bearing with a new one if it is noisy or has excessive play.

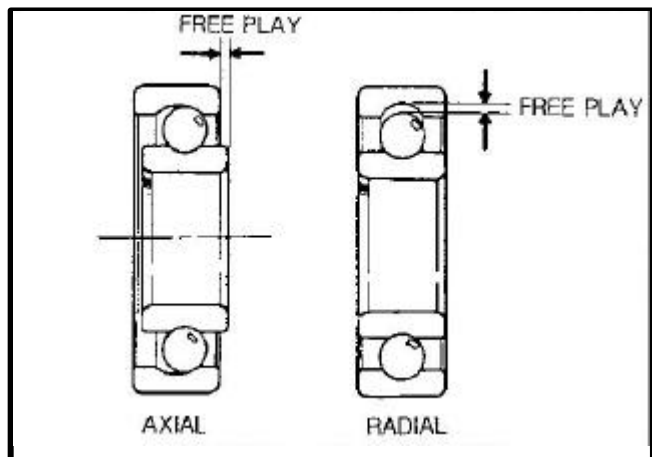

FRONT BRAKE**FRONT BRAKE DISC INSPECTION (DISC BRAKE)**

Replace the brake pads if the wear indicator mark is pointed.

Measure the brake disc thickness.

Service limit: 3.5mm

**FRONT BRAKE DISASSEMBLY**

Remove the caliper by removing the two caliper mounting bolts.

Remove the pad guide bolts.

Remove the brake pads.

CAUTION:

Do not operate the brake lever after the caliper removal to avoid brake pads sticky.

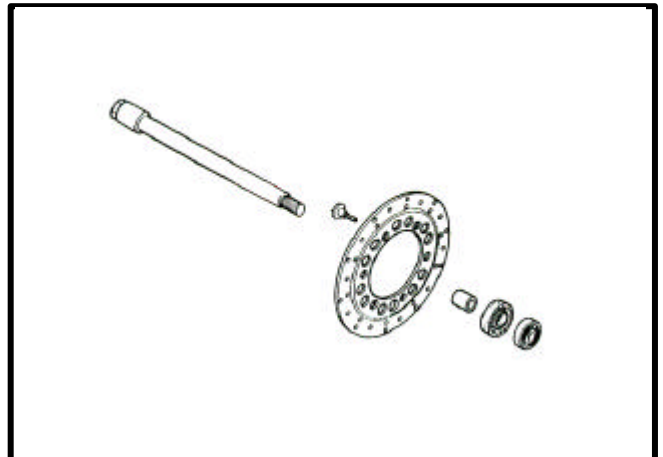
**FRONT BRAKE ASSEMBLY**

Reverse the procedures of disassembly to install the brake pads.

Tighten the brake pad guide bolts.

**FRONT BRAKE LINING INSPECTION (DRUM BRAKE)**

Measure the brake lining thickness.

Service limit: 2.0mm

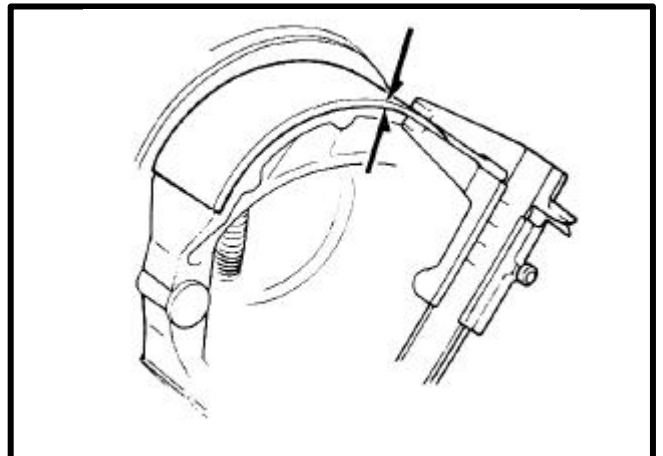

FRONT BRAKE PANEL INSPECTION

Remove the brake shoes and springs.
 Remove the brake arm and brake cam.
 Remove the speedometer drive gear and dust seal.

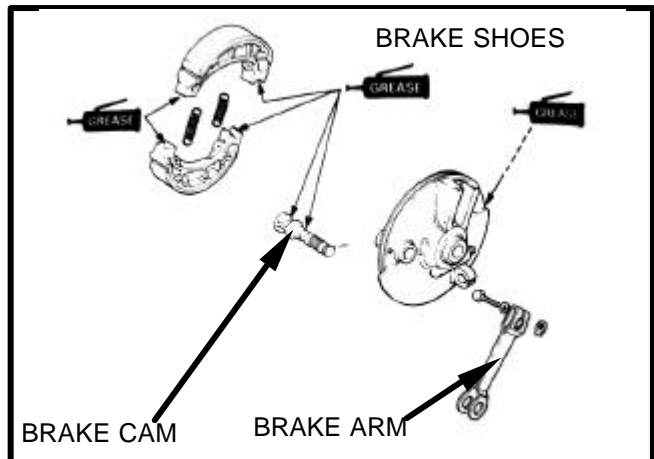

FRONT BRAKE PANEL ASSEMBLY

Install a new dust seal.
 Apply grease to the speedometer gear and install the gear.
 Apply grease to the sliding surfaces of the brake cam and shoes as shown in the figure above.
 Install the brake cam and brake arm aligning the punch mark on the brake arm with the punch mark on the cam.
 Install the brake shoes and springs.

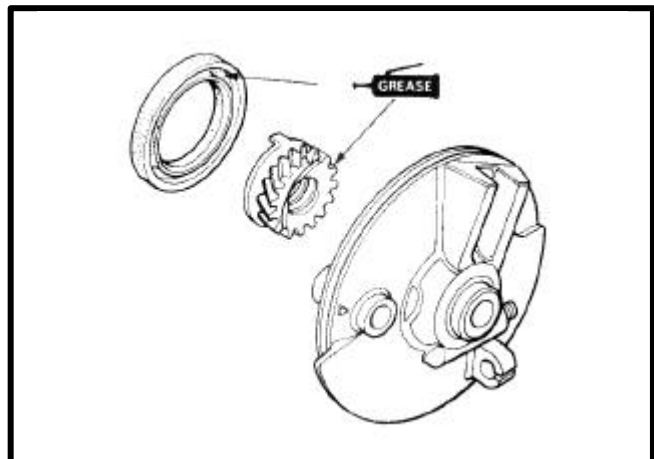

FRONT WHEEL RIM INSPECTION

Check the wheel rim runout by placing the wheel on the turning stand.
 Service limit:
 Axial: 2.0mm under
 Radial: 2.0mm under

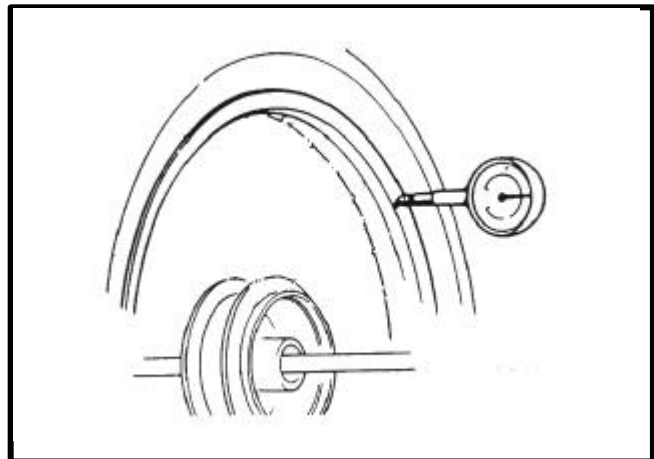

FRONT WHEEL ASSEMBLY

Apply grease to the wheel bearings.
 Install the right bearing and center collar.
 Install the left bearing and dust seal.
 Install the side collar.

NOTE:

Install the bearing with the sealed end facing the outside.



FRONT WHEEL INSTALLATION

Install the front wheel.
Install the axle shaft from the right side.
Tighten the axle nut.
TORQUE: 600-800 kgf . cm
Connect the speedometer cable.



FRONT FORK FRONT FORK REMOVAL

Remove the front wheel.
Remove the brake caliper bolts.
Remove the front fender.

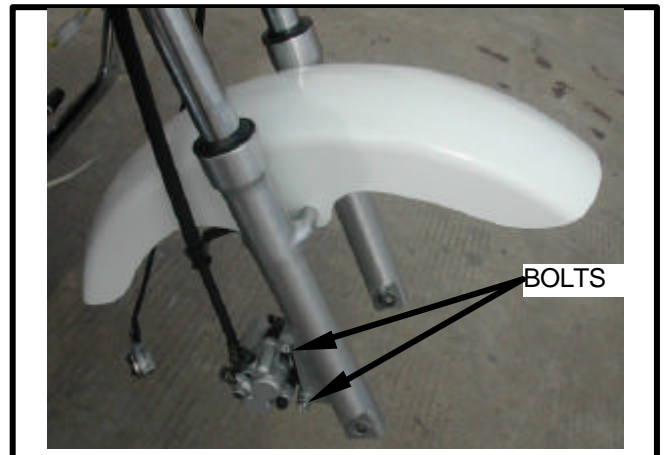

Remove the fork top bridge bolts.

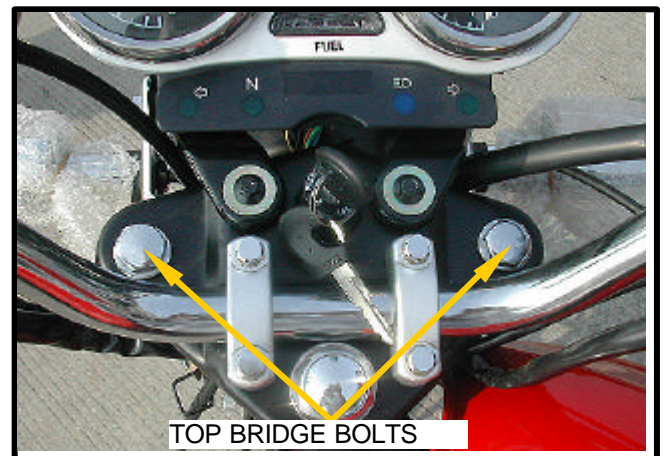

Loosen the fork bottom bridge, remove the front shock absorber assembly.

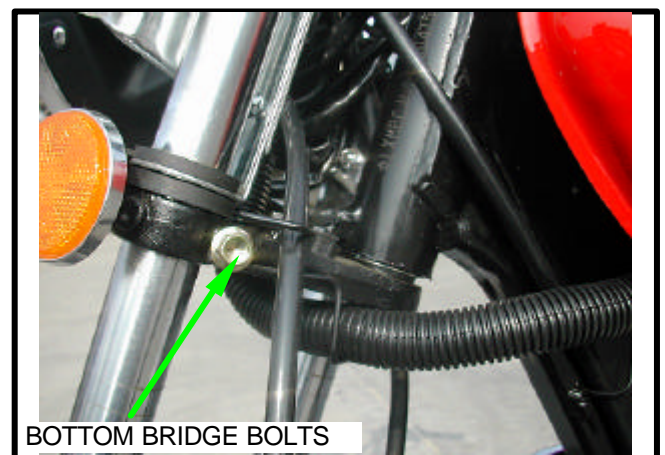

If the front fork is too soft or too hard, refill or drain the shock absorber fluid.

Shock absorber fluid:

CUSHION OIL

Standard capacity :160c.c

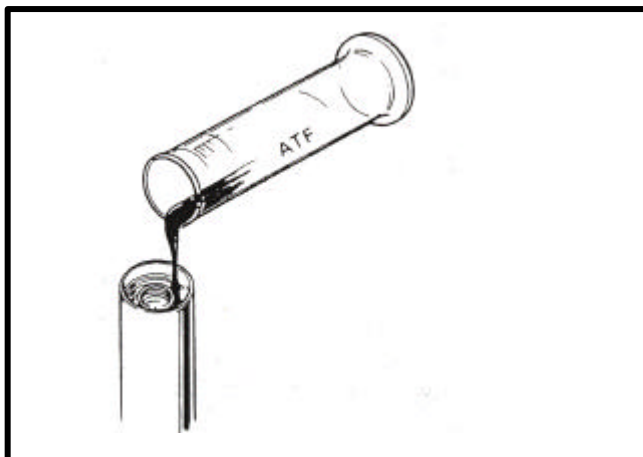

FRONT FORK INSTALLATION

Install the front fork from the bottom.

NOTE:

Turn the front fork left and right by hand while installing.



Tighten the fork top bridge bolts.

TORQUE: 400-550 kgf. cm

Tighten the fork bottom bridge bolts.

TORQUE: 400-550 kgf. cm

Install the front fender.

Install the front wheel.



STEERING STEM

FRONT FORK TOP REMOVAL

Remove the handlebar.

Remove the headlight and meter assembly.

Remove the front fork.

Remove the steering stem nut and washer.

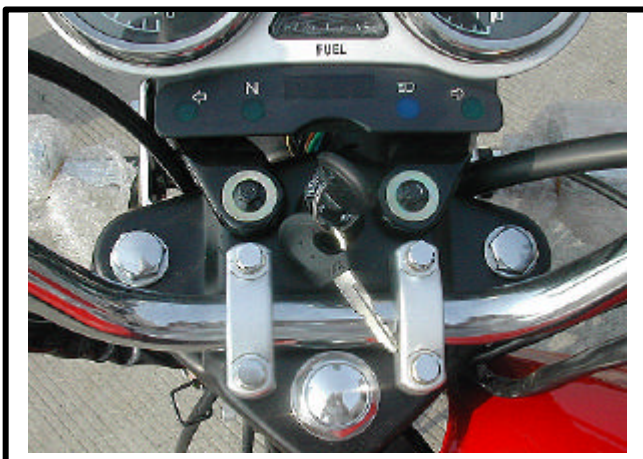

STEERING STEM DISASSEMBLY

Remove the front fork top bridge bolts.

NOTE:

Do not let the steel balls fall.

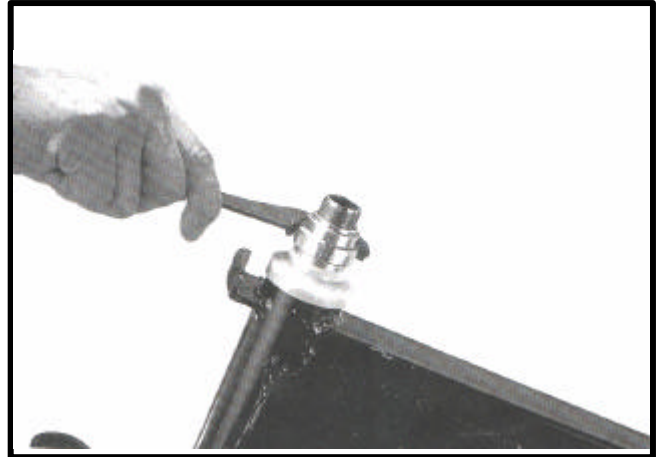

Remove the steel balls cone brace, steering stem and steel balls.

Check the top and bottom cone races and steel balls for wear or damage and replace if necessary.

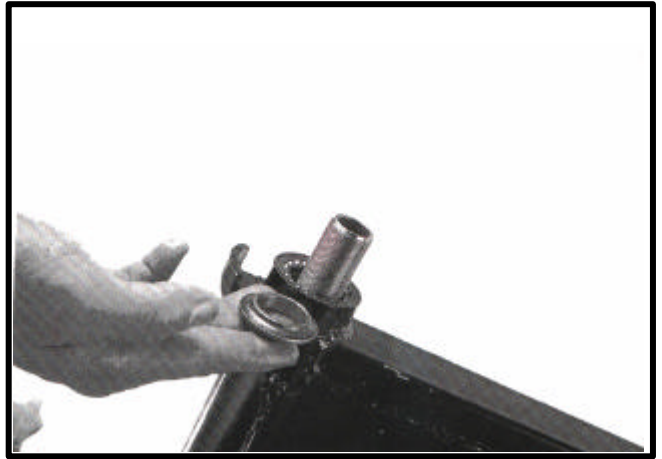

STEERING STEM ASSEMBLY

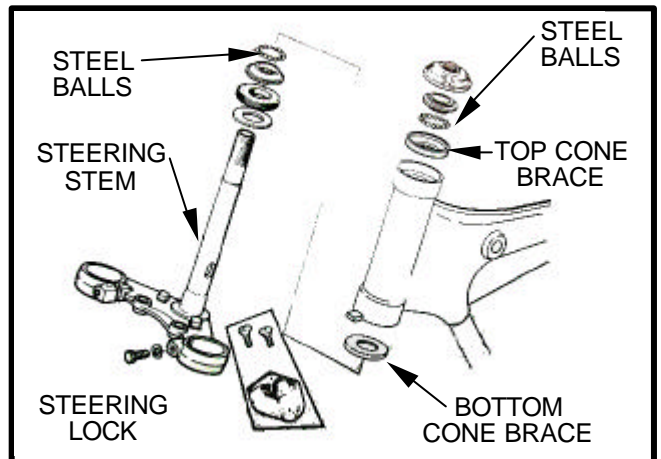

Install the steel balls cone race.

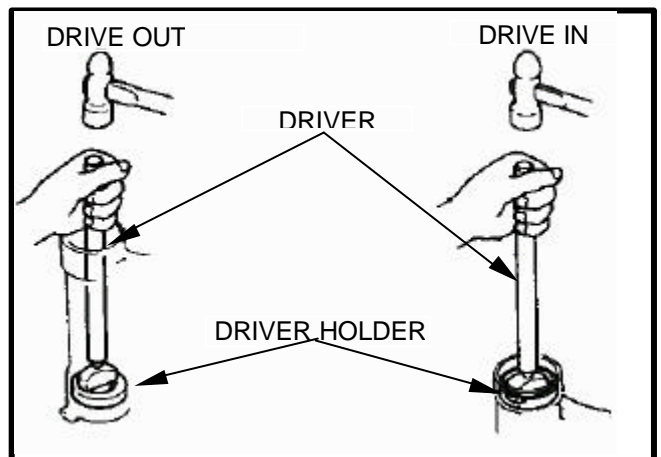

11. HEADLIGHT/STEERING FRONT WHEEL/FRONT FORK



Grease the steel balls and cone races, install the steering stem.



Install the steering top nut and tighten it until snug against the upper cone race.
Back the top nut out 1/8 turn to let steering stem be able to rotor freely.

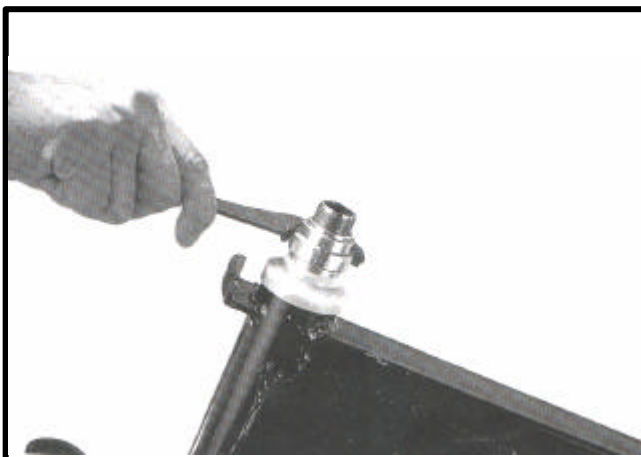

Install the front fork top bridge.
Install the front fork.
Tighten the front fork bottom bridge bolts.
TORQUE: 400-550 kgf. cm

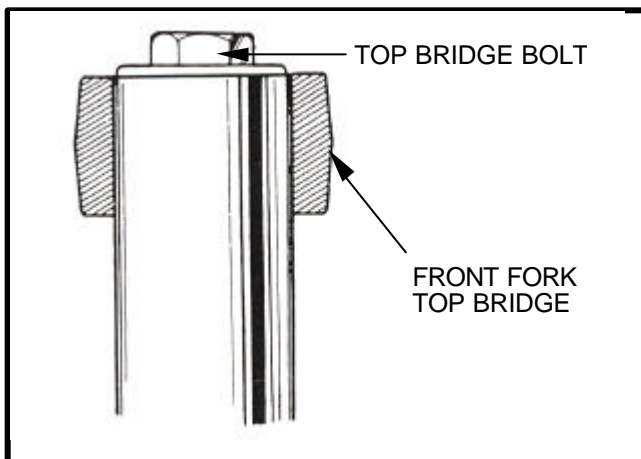

Tighten the steering stem nut.
TORQUE: 600-800 kgf. cm
Tighten the front fork top bridge bolts.
TORQUE: 400-550 kgf. cm
Install the handlebar, meter, headlight and front wheel.

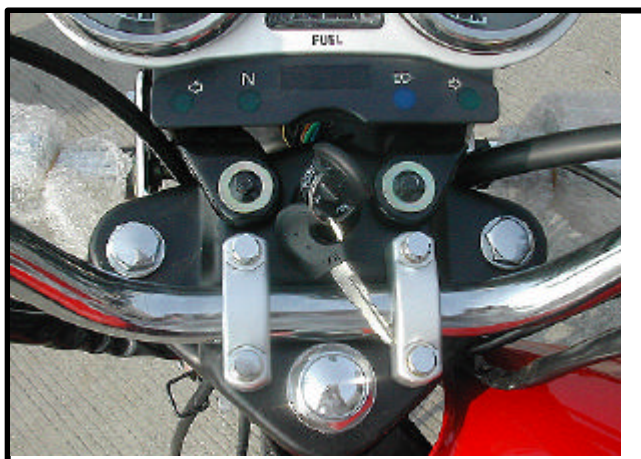

TROUBLE SHOOTING.....12-1	SHOCK ABSORBER.....12-6
SERVICE INFORMATION.....12-1	REAR FORK.....12-8
REAR WHEEL.....12-2	REAR BRAKE PEDAL.....12-9
REAR BRAKE PANEL.....12-5	

TROUBLE SHOOTING

WOBBLE OR VIBRATION IN MOTORCYCLE

1. Loose rear wheel bearing
2. Distorted rim
3. Tire pressure too high
4. Loose axle nut

SOFT SUSPENSION

1. Weak spring
2. Shock absorber faulty or too soft

HARD SUSPENSION

1. Bent damper shaft
2. Faulty shock absorber stopper rubber

SUSPENSION NOISE

1. Loose fasteners
2. Faulty shock absorber stopper rubber
3. Damper leaking
4. Damper and spring binding

POOR BRAKE PERFORMANCE

1. Improper brake adjustment
2. Brake linings oily or worn
3. Worn brake drum
4. Brake arm serrations improperly engaged

SERVICE INFORMATION

TORQUE VALUES

Rear wheel axle nut	1000 ~ 1200 kgf · cm
Rear fork pivot bolt nut	800 ~ 1000 kgf · cm
Rear brake torque link nut	150 ~ 200 kgf · cm
Shock absorber nut	300 ~ 400 kgf · cm
Final driven sprocket	270 ~ 330 kgf · cm
Drive sprocket bolt	100 ~ 140 kgf · cm

SPECIFICATIONS

ITEM		STANDARD SERVICE	LIMIT
Rear axle runout		0 ~ 0.01mm	0.2mm
Rim runout	Axial	2.0mm
	Radial	2.0mm
Brake drum I.D		150mm	152mm
Brake lining thickness		4.3mm	2.0mm
Shook absorber spring free length		195.3mm	183mm
Rear fork bushing clearance		0.2 ~ 0.3mm	0.5mm

REAR WHEEL

REAR WHEEL REMOVAL

Raise the rear wheel off the ground on the main stand.

Remove the exhaust muffler.



Disconnect the brake rod from the brake arm.
Disconnect the brake torque link from the brake panel.

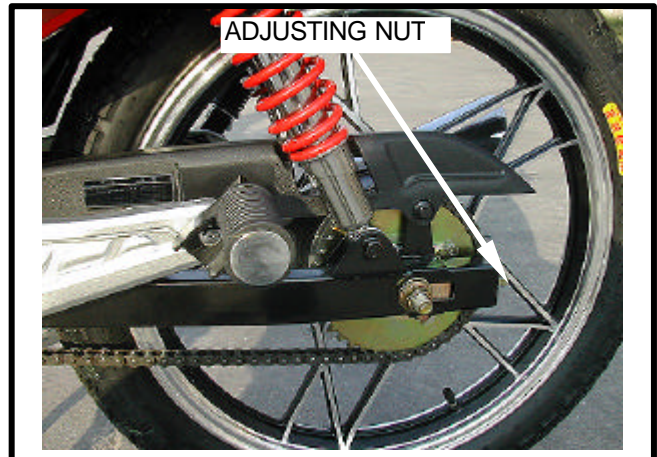

Remove the axle nut and loose the chain adjusting nut. Pull out the axle shaft and remove the drive chain from the drive sprocket, then remove the rear wheel.



AXLE INSPECTION

Set the axle in the V-blocks and measure the runout. The actual runout is 1/2 of the total indicator reading. service limit: 0.2mm under

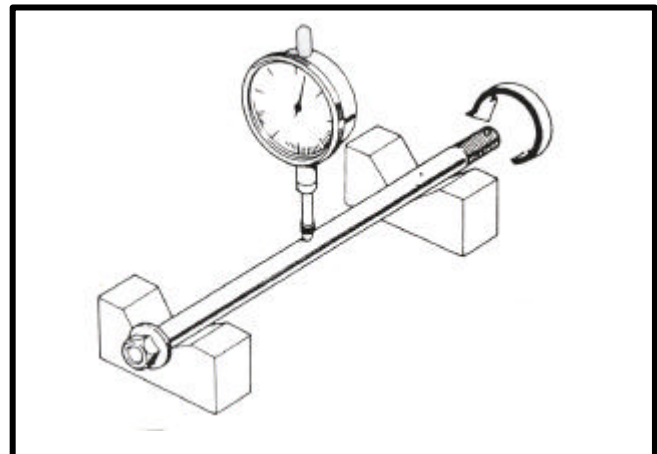

BEARING FREE PLAY INSPECTION

Shake the bearing back and forth and spin it by hand, replace it with a new one if it is noisy or has excessive free play.

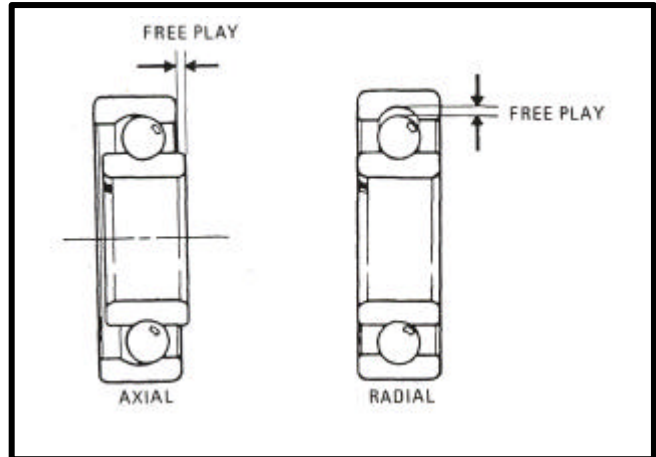

WHEEL RIM RUNOUT INSPECTION

Check the rim runout by placing the wheel in a turning stand. Turn the wheel by hand and read the runout using a dial indicator gauge.

TORQUE: 25-50 kgf · cm

Runout:

Axial: 2.0mm under

Radial: 2.0mm under

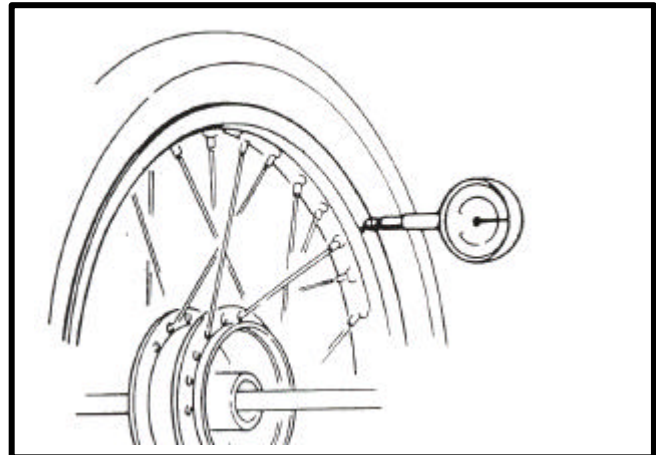

FINAL DRIVEN SPROCKET

INSPECTION

Check the condition of the final driven sprocket teeth. Replace the sprocket if it is worn.

NOTE:

The drive chain and drive sprocket must be also inspected for wear.

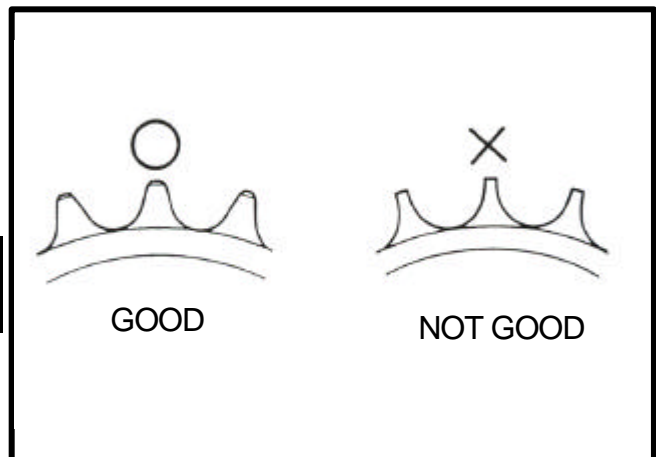

DAMPER RUBBER INSPECTION

Check the damper rubbers for wear or damage and replace if necessary.



FINAL DRIVEN SPROCKET ASSEMBLY

Install the drive sprocket and new lock plates on the driven flange and tighten them with the bolts and nuts.

TORQUE:240~300 kg f · cm

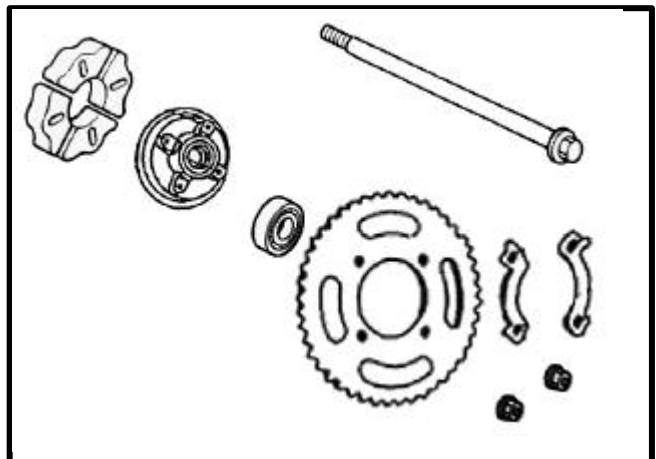

Bend up the lock plate tabs against the nuts.

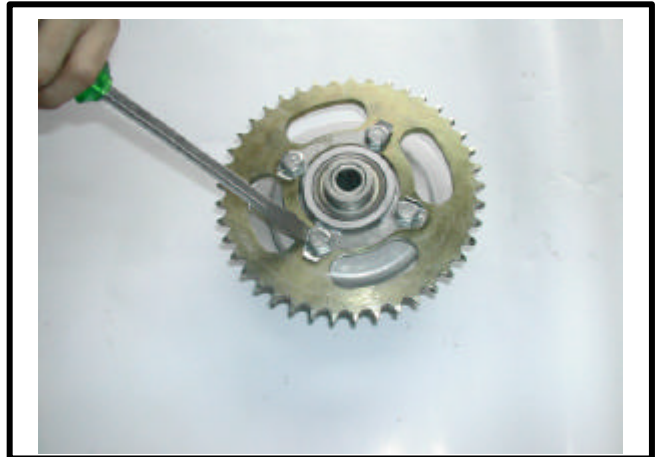

Install the driven flange on the wheel hub.



Measure the brake drum I.D.
 Service limit: 152mm

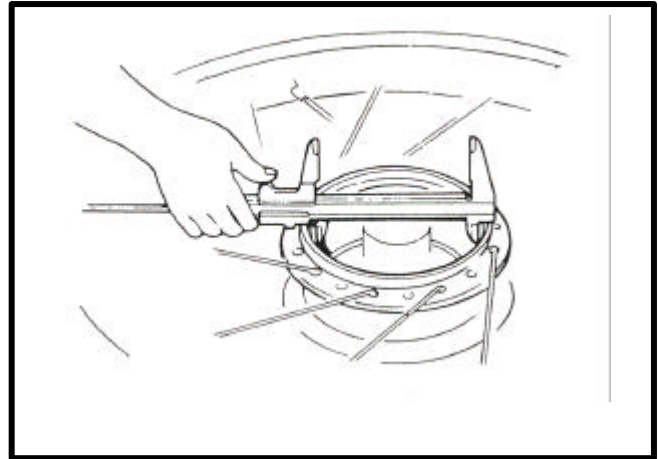

REAR BRAKE PANEL

NOTE:

Grease the place as figure.

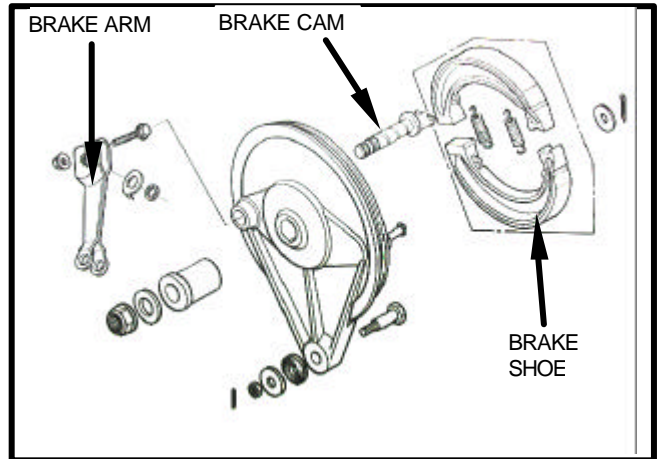

BRAKE SHOE INSPECTION

Measure the lining thickness.
 Service limit: 2.0mm

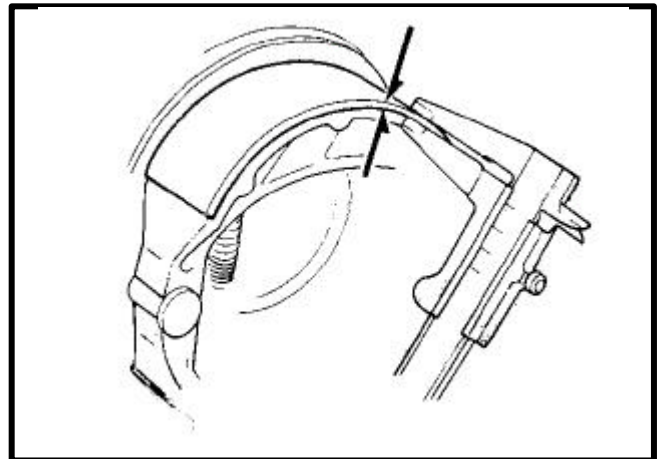

BRAKE SHOE REPLACEMENT

Separate the brake shoes with the brake cam.
 Remove the brake shoes and springs.
 Grease the brake cam.
 Install the new brake shoes.

WARNING:

Contaminated brake lining reduces stopping power.
 Keep grease off the lining.



12. REAR WHEEL/REAR SUSPENSION



Install the hold arm.
Install the brake linkage.

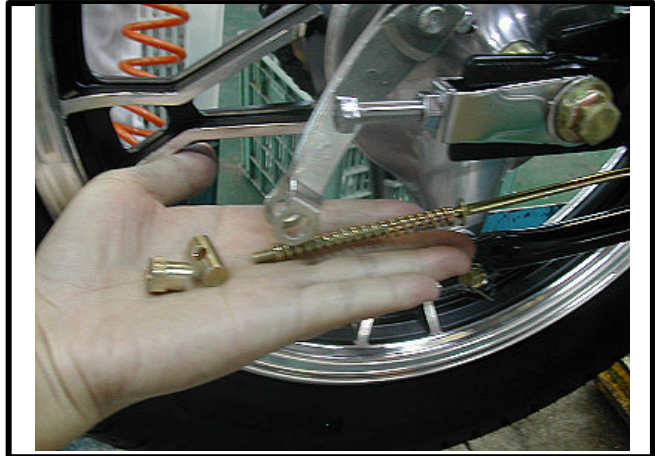

Adjust the drive chain tension (2-13).
Drive chain slack: 10 ~ 20mm
Tighten the chain tension adjusters.
Tighten the axle nut.
TORQUE: 1000 ~ 1200 kg f · cm
Apply engine oil to the drive chain.
Install the step bar and the muffler.

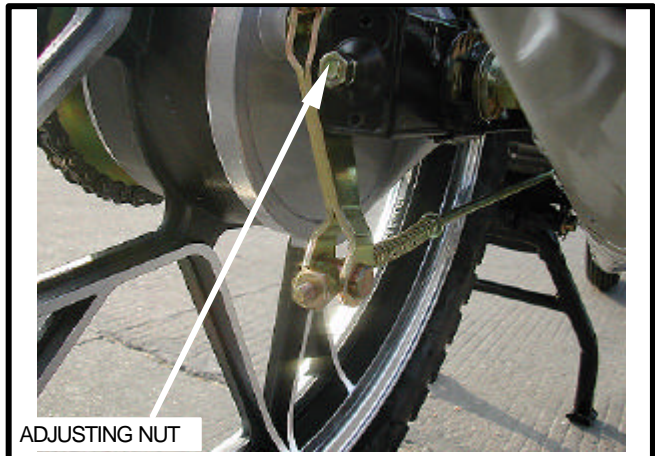

SHOCK ABSORBER

SHOCK ABSORBER REMOVAL

Remove the left and right shock absorber assembly.

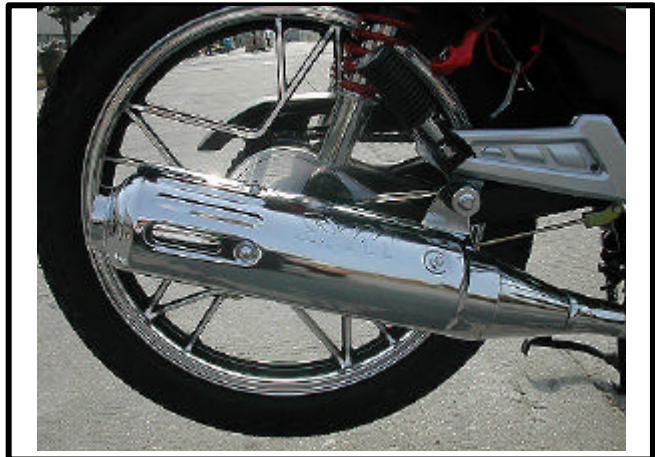

SHOCK ABSORBER DISASSEMBLY

Compress the shock absorber spring with a shock absorber compressor.
Loosen the lock nut, remove the upper holder.

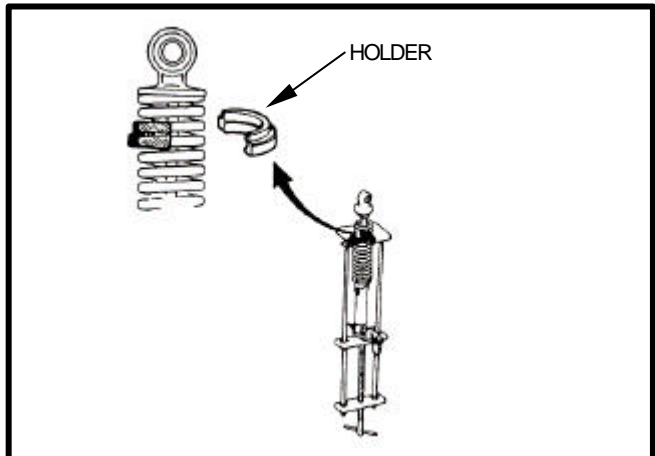

Remove the spring and rubber.

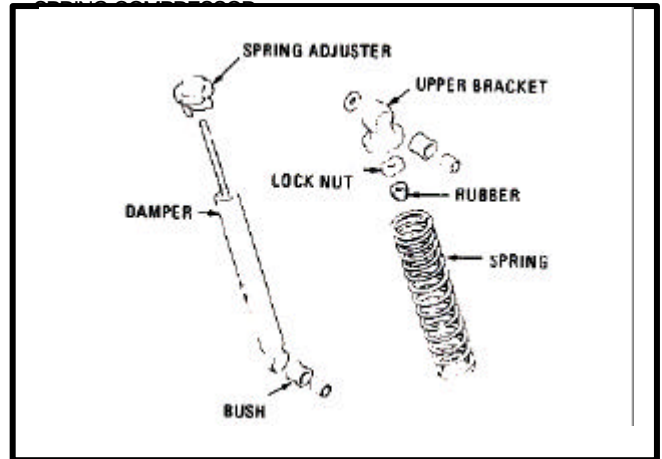

SHOCK ABSORBER SPRING INSPECTION

Measure the shock absorber spring free length.
Service limit: 183mm
Check the shock absorber for noisy or leaks.

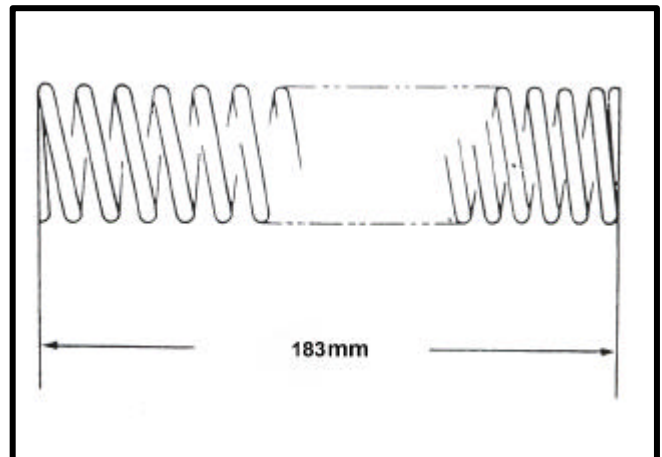

SHOCK ABSORBER ASSEMBLY

NOTE:

Install the spring with the tightly wound coils at the top.

TORQUE: 150-250kgf · cm

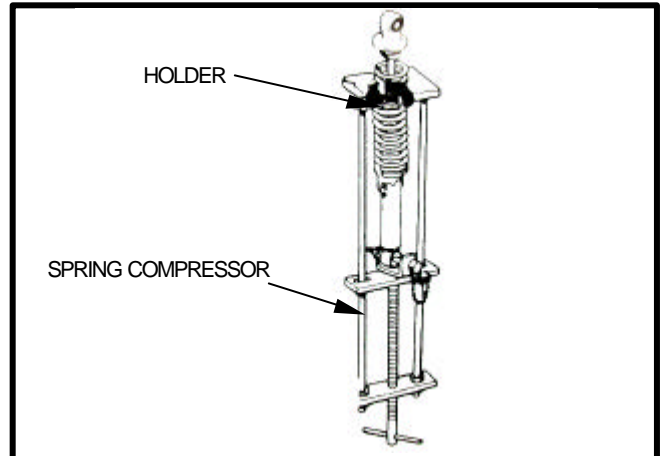

SHOCK ABSORBER INSTALLATION

Tighten the shock absorber upper and lower mounting nuts.

TORQUE: 300-400 kgf · cm

Check the shock absorber operation.

NOTE:

- Adjust the right and left absorber to the same scales.
- The standard position is "1".

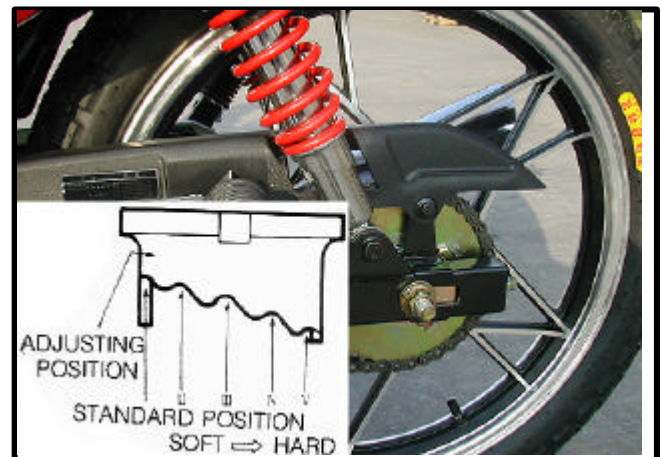

REAR FORK

REAR FORK REMOVAL

- Remove the muffler.
- Remove the rear wheel (12-3).
- Remove the rear shock absorber (12-9).
- Remove the drive chain cover.
- Remove the rear fork mounting bolts.

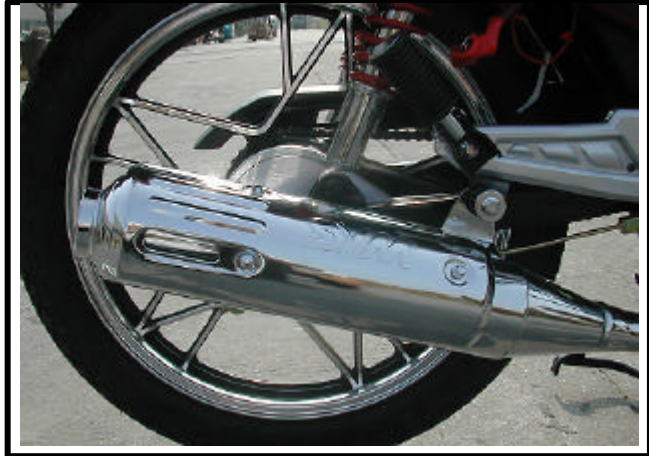

REAR FORK DISASSEMBLY/ASSEMBLY

NOTE:

Drive the bushings out with a soft hammer, making sure that they are not damaged. Lubricate with grease after installation.

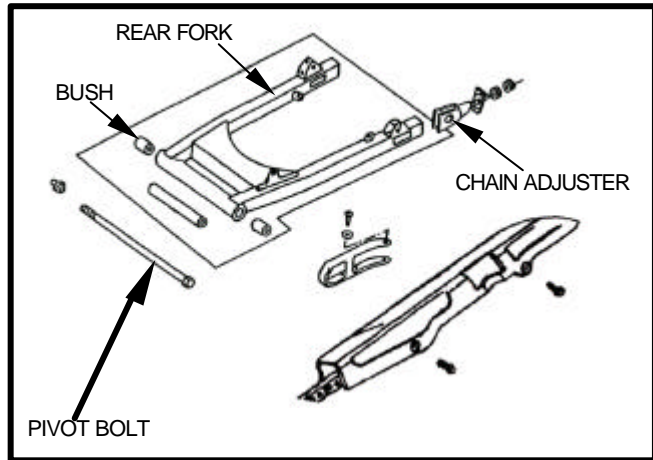

REAR FORK INSPECTION

- Inspect the pivot bushing for cracks or damage.
- Check each part for wear or damage.



REAR FORK INSTALLATION

Install the rear fork.

TORQUE: 800~1000 kgf · cm

Install the rear shock absorber and rear wheel.

Install the muffler.

**REAR BRAKE PEDAL**

Remove the muffler.

Remove the brake linkage rod.

Remove the brake light switch spring.

Remove the brake return spring.

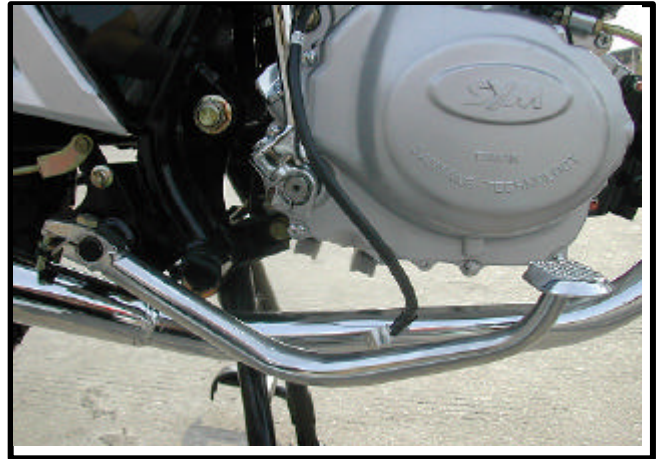

Adjust the rear brake after installation.

NOTE :

Do not forget to install the brake light switch spring.

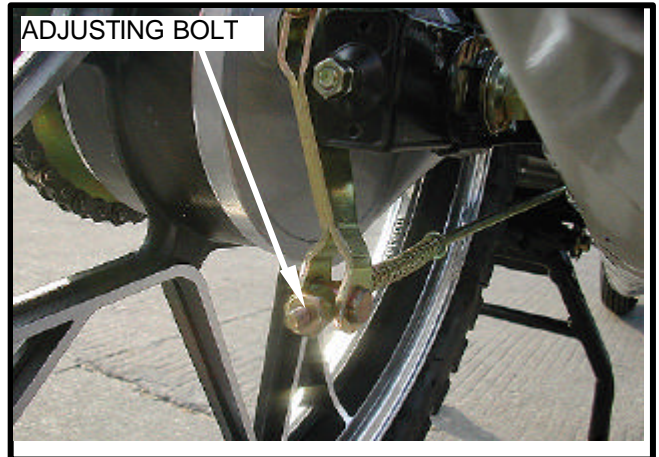

TROUBLE SHOOTING.....	13-1	BATTERY.....	13-3
SERVICE INFORMATION.....	13-2	CHARGING SYSTEM.....	13-4

TROUBLE SHOOTING

NO POWER --- KEY TURNED ON

1. Dead battery
 - Battery electrolyte evaporated
 - Battery not charged
 - Charging system failure
2. Disconnected battery cable
3. Main fuse burned out
4. Faulty ignition switch

LOW POWER --- KEY TURNED ON

1. Weak battery
 - Low battery electrolyte level
 - Charging system failure
2. Loose battery connection

LOW POWER --- ENGINE RUNNING

1. Battery undercharged
 - One or more dead cells
 - Low battery electrolyte level
2. Charging system failure
3. Generator failure
4. Faulty voltage regulator
5. Faulty ignition coil
6. C.D.I. UNIT failure

INTERMITTENT POWER

1. Loose battery connection
2. Loose charging system connection
3. Loose connection or short circuit in ignition system
4. Loose connection or short circuit in light system

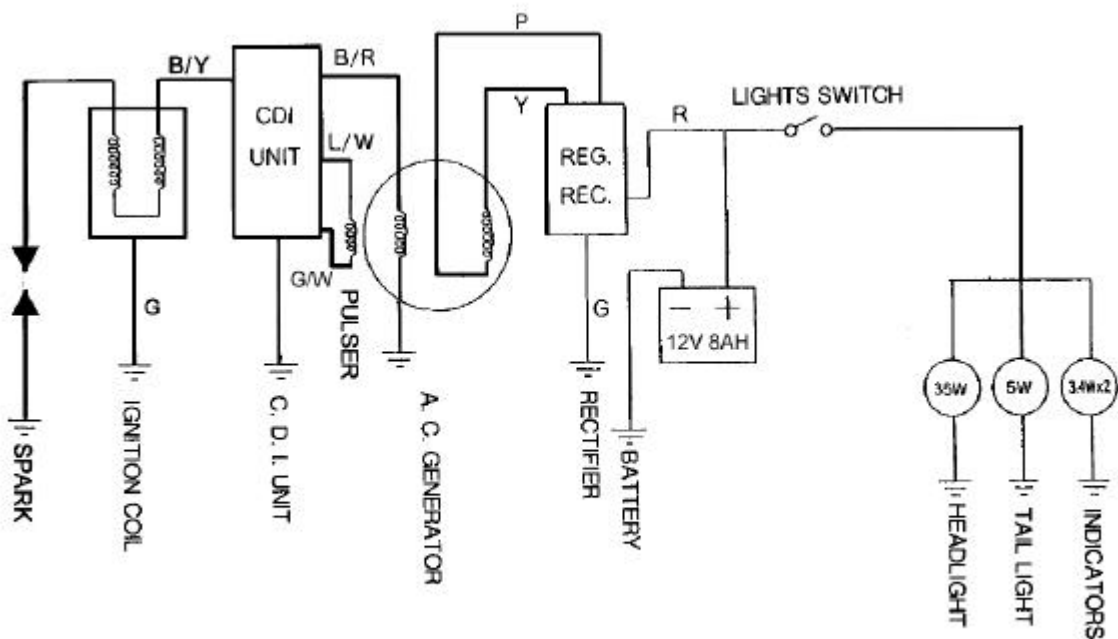

CHARGING SYSTEM FAILURE

1. Loose broken or shorted wire
2. Faulty voltage regulator
3. Faulty generator
4. Battery undercharged

SERVICE INFORMATION

GENERAL INSTRUCTIONS

1. Battery acid level should be checked and refill with distilled water when necessary.
2. When charging the battery, quick-charging should only be done in an emergency; slow charging is preferred.
3. Remove the battery from the motorcycle for charging whenever possible. If battery must be charged on the motorcycle, keep away from flames or sparks.
4. The parts of charging system can be tested on the motorcycle.
5. Refer to section 8 for generator removal and installation.

SPECIFICATIONS

Battery	
Capacity	12 & 8AH
Electrolyte specific gravity	1.260-1.280 (2000/68~F)
Charging current	0.9A
A.C. generator	150W/5,000rpm
Charging output	1,000 max. (Day)
Charging rpm	2,500 max. (Night)
Rectifier	Three-way full wave
Fuse	15A

BATTERY

BATTERY REMOVAL AND INSTALLATION

Remove the right side cover.
 Disconnect the battery negative cable first, then the battery positive cable.
 Disconnect the battery band, remove the battery.

BATTERY INSTALLATION

Put the battery on the battery rack.
 Install the battery band.
 Connect the battery positive cable first, then the battery negative cable.
 Install the right side cover.



SPECIFIC GRAVITY TEST

Test each cell by using a hydrometer.

SPECIFIC GRAVITY :

1.260-1.280	Fully charged
1.220 or below	Undercharged

(20 /68 ° F)

NOTE ~

- The battery must be recharged if the specific gravity is below 1.23.
- The specific gravity varies with the temperature as shown in the accompanying table.
- Replace the battery if sulfating is evident.
- The battery must be replaced if there are pastes on the bottom of each cell.

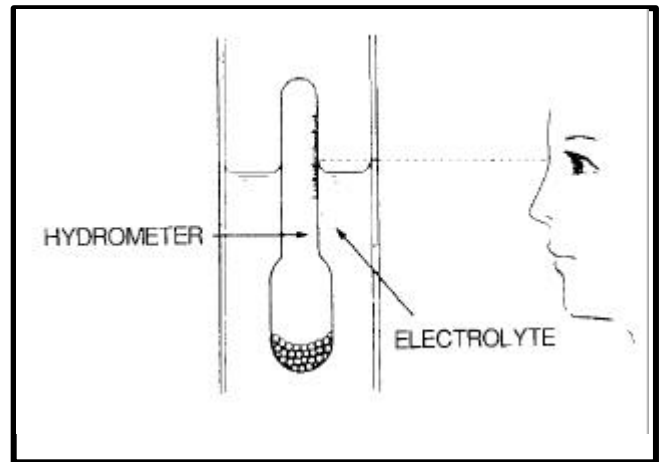

WARNING:

- The battery electrolyte contains sulfuric acid. Protect your skin, eyes and clothing. Note the followings:
1. In case of contact, flush thoroughly with water.
 2. In case of drinking, drink mass of water or milk, and eat the white of an egg or drink vegetable oil.
 3. Cover the eyes when operating at short distance, in case of contact, flush thoroughly with water and spread of eye-ointment.
 4. Keep flames and sparks away from a charging battery.
 5. Place the charging battery in a ventilate area.

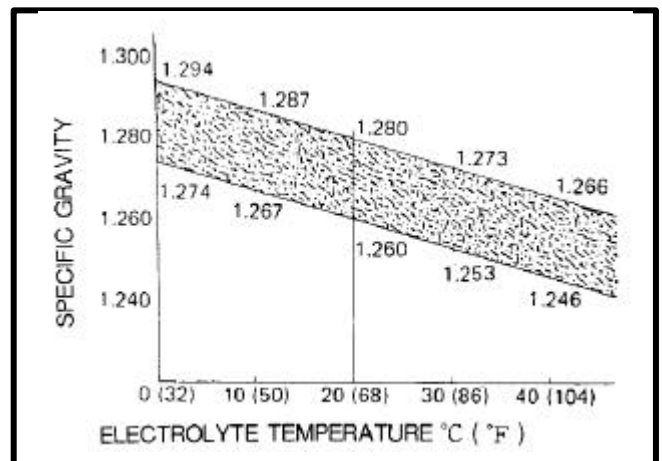

13. BATTERY/CHARGING SYSTEM



Connect the charger positive(+) cable to the battery positive (+) terminal, negative (-) cable to the battery negative (-) terminal.

Charge the battery until the specific gravity of the electrolyte is 1.260-1.280 (20 /68)

Charging current: 0.7A max.

WARNING:

Before charging a battery, remove the cap from each cell.
Keep flames and sparks away from a charging battery.
Connect the cables first, then turn on the power.
Discontinue charging if the electrolyte temperature exceeds 45 (113).

CAUTION:

Quick-charging only be done in an emergency; slow-charging is preferred.

After installed the battery, coat the terminals with clean grease to keep from oxidation.

CAUTION:

Route the breather tube as shown on the battery caution label.

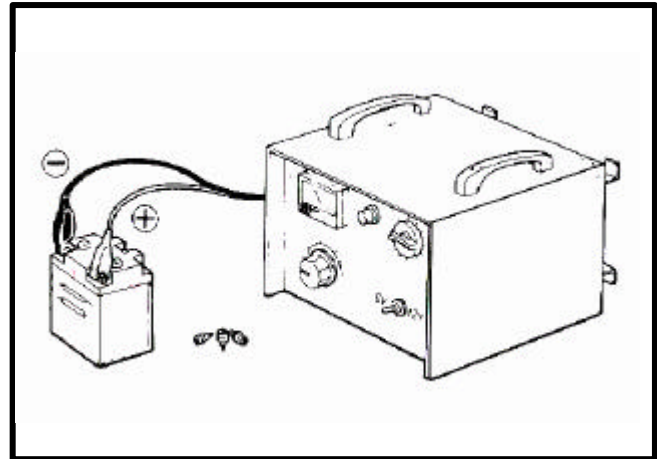

CHARGING SYSTEM

PERFORMANCE TEST

Warm up the engine before taking readings.

Connect a voltmeter and an ammeter to check charging output.

NOTE:

Use a fully charged battery to check the charging system output.

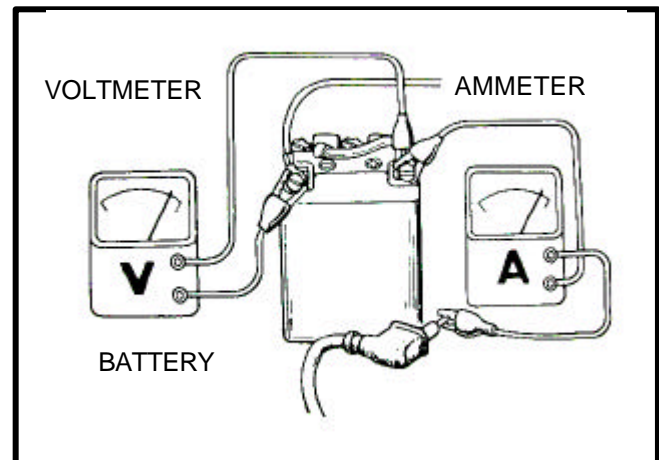

STATOR COILS TEST

NOTE:

This test can be made with the stator on the frame.

Disconnect and measure the A.C. generator connectors with a multi-meter.
 Conductivity should exit between :
 Pink- yellow,blue/white-green/white,black/red-ground.
 Pink,yellow,blue/white,green/white should not conduct electricity with ground.



RECTIFIER

Disconnect the rectifier connector and check its performance.

WARNING:

Do not use high voltage power, especially the ohmmeter, or the rectifier will be burnt out.

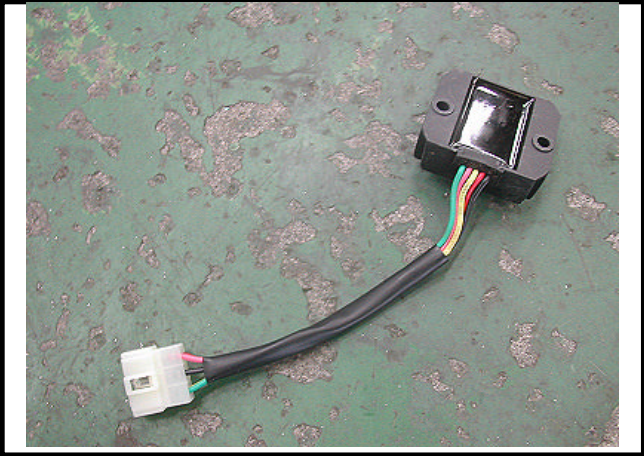
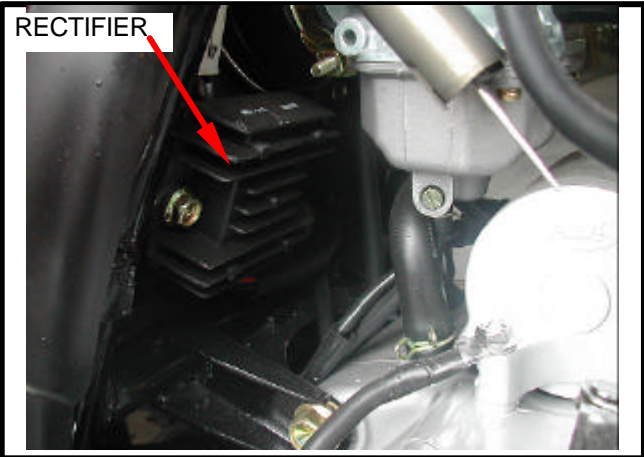

(-)					
(+)	RED	GREEN	YELLOW	PINK	BLACK
RED					
GREEN					
YELLOW					
PINK					
BLACK					

Rectifier is normal if there is continuity only in the direction shown. Replace the rectifier if there is continuity in reverse direction.

TROUBLE SHOOTING14-1 SERVICE INFORMATION.....14-2	IGNITION COIL 14-3
--	--------------------------

TRUBLE SHOOTING

ENGINE CRANKS BUT NOT START

1. No sparks at the spark plug
2. Improper ignition timing
3. Faulty plug

NO SPARKS AT THE SPARK PLUG

1. No current in primary circuit
2. High tension cord broken
3. Faulty ignition coil
4. Faulty A.C. generator
5. Faulty C.D.I. unit

ENGINE RUNS BUT ROUGHLY

1. Primary circuit
 - C.D.I. unit failure
 - Faulty A.C. generator
 - Faulty ignition coil
 - Loose wires
 - Poorly contacted switch terminals
2. Secondary circuit
 - Faulty,spark plug
 - Faulty high tension cord
 - Faulty ignition coil
3. Ignition timing
 - Faulty A.C. generator
 - Faulty C.D.I. unit

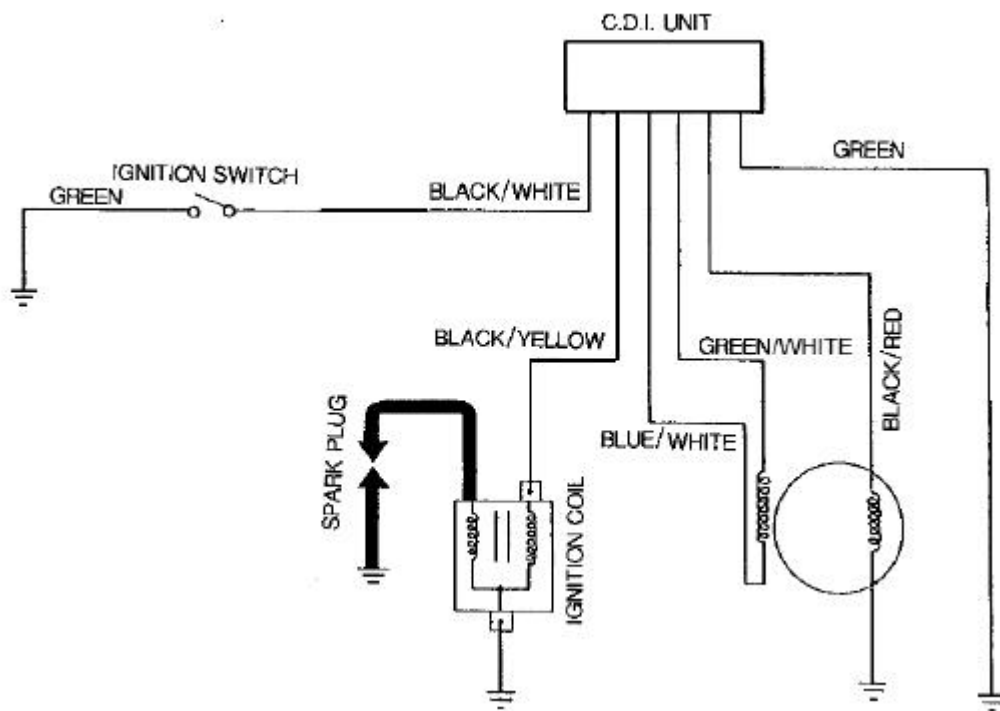
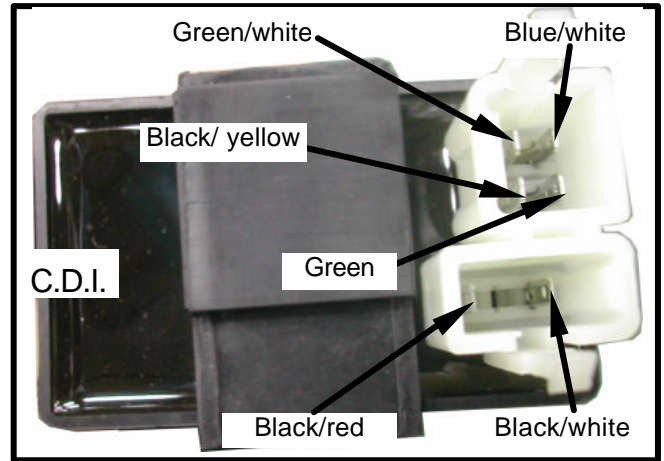

SERVICE INFORMATION

GENERAL INSTRUCTION

This section contains the ignition system.

Be sure that the battery is fully charged before diagnosing troubles in the ignition system.

Also refer to the following pages:

Spark plug	2-5
Ignition timing adjustment	2-8

SPECIFICATIONS

Spark plug:	D7RC
Spark plug gap:	0.6~0.7mm(0.024-0.028in)
Ignition timing :Initial	15° ± 2°/1500rpm
Full advance	29.5° ± 2° /4000rpm

IGNITION COIL

IGNITION COIL REMOVAL

- Remove the seat.
- Remove the fuel tank.
- Remove the spark plug cap.
- Disconnect all wires to the ignition coil.
- Remove the ignition coil.

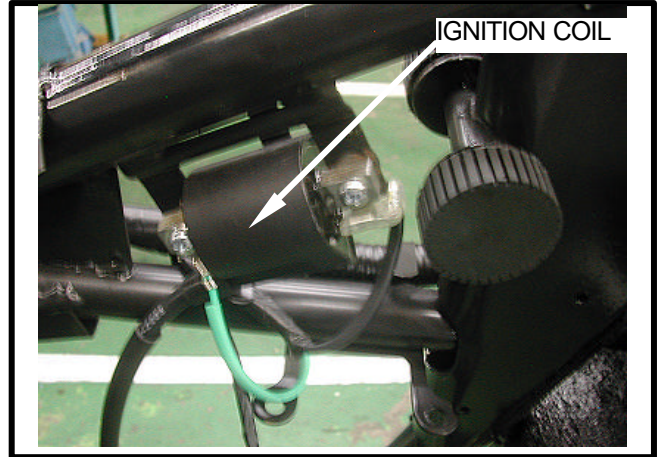

IGNITION COIL TEST

Check the ignition coil output using a tripolar tester.

NOTE:

Follow the instructions described in the user manual.

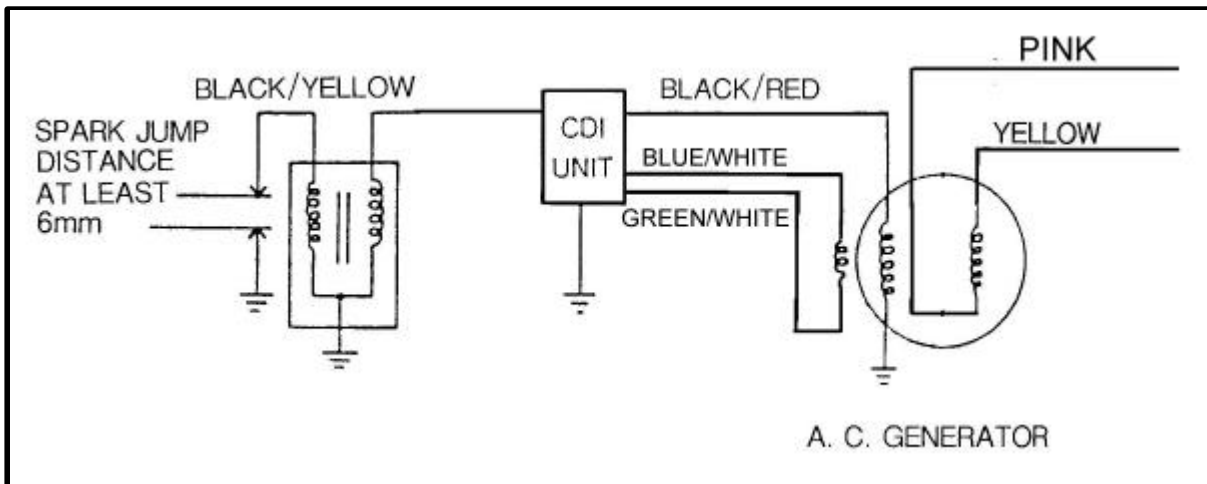

Check the primary circuit, it is normal if there is conductivity when connecting a ohmmeter.

PRIMARY COIL	$0.31 \pm 0.03K$
SECONDARY COIL	$4.0 \pm 0.4K$

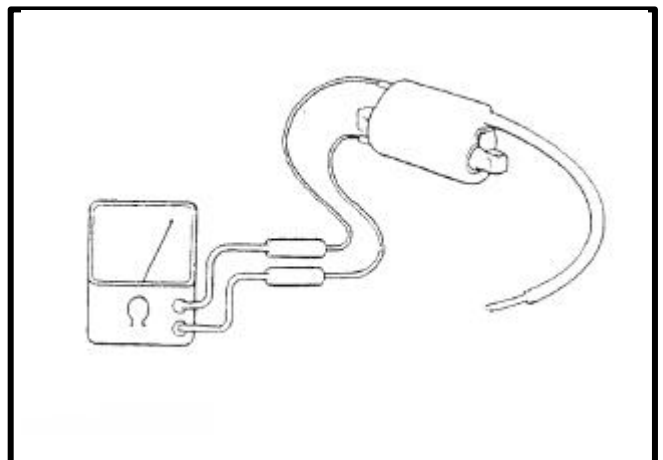

TROUBLE SHOOTING.....15-1	HEADLIGHT SWITCH.....15-3
SERVICE INFORMATION.....15-2	START/HAZARD SWITCH.....15-3
MAIN/DIMMER SWITCH.....15-3	FRONT/REAR BRAKELIGHT SWTICH.....15-4
WINKER/HORN SWITCH.....15-3	HORN SWTICH.....15-4
HEADLIGHT SWITCH.....15-3	

TROUBLE SHOOTING**NO LIGHTS COME ON WHEN IGNITION****SWITCH IS TURNED ON:**

1. Battery low
2. Wiring loose or blown
3. Fuse blown
4. Open or shorted wiring
5. Faulty combination switch
6. Bulb at fault or burned out

ALL LIGHTS COME ON BUT DIMLY WHEN**IGNITION SWITCH IS TURNED ON:**

1. Battery low
2. Wiring or switch has excessive resistance

HEADLIGHT BEAMS DO NOT SHIFT WHEN**HIGH-LOW SWITCH IS OPERATED:**

1. Faulty dimmer switch
2. Faulty headlight switch

SERVICE INFORMATION

GENERAL INSTRUCTIONS

All electrical wires are color-coded. Check the color before connecting wires.

All plastic plugs have locking tabs that must be released before disconnecting, and must be aligned when reconnecting.

A conductivity check can usually be made without removing the part from the motorcycle by simply disconnecting the wires and connecting a galvanometer or voltmeter to the terminals or connections.

SPECIFICATIONS

Headlight	12V 35/35W
Winker light	12V 10W
Tail / Stop light	12V 5W/21W
Speedometer light	12V 3.4W x 2
Neutral pilot	12V 3.4W
Winker indicator	12V 3.4W
High beam pilot	12V 1.7W

MAIN SWITCH

WIRE COLOR \ SWITCH POSITION	BLACK/WHITE BW	GREEN G	RED R	BLACK B	BROWN/RED Br/R	BROWN Br

			---		---	
P	---		---	---	---	---

DIMMER SWITCH

WIRE COLOR \ SWITCH POSITION	WHITE W	BLUE L	BROWN/WHITE Br/W

	---	---	---

WINKER SWITCH

WIRE COLOR \ SWITCH POSITION	SKY BLUE SB	GRAY Gr	ORANGE O

HORN SWITCH

WIRE COLOR \ SWITCH POSITION	GREEN G	LIGHT GREEN LG
	---	---

LIGHT SWITCH

WIRE COLOR \ SWITCH POSITION	BLACK B	BROWN Br	BROWN/WHITE Br/W
	---	---	---
	---	---	

START SWITCH

WIRE COLOR \ SWITCH POSITION	YELLOW/RED Y/R	BLACK B
	---	---

HAZARD SWITCH

WIRE COLOR \ SWITCH POSITION	GRAY Gr	ORANGE O	SKY BLUE SB
	---	---	

15. SWITCHES/HORN



FRONT BRAKELIGHT SWITCH

Check that the front brakelight switch for conductivity between the BLACK and GREEN/YELLOW wires. The switch is normal if there is conductivity with the front brake applied.

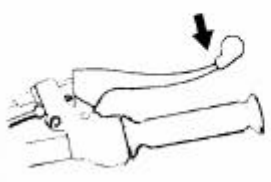
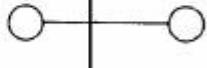
SWITCH	WIRE COLOR	
	BLACK B	GREEN/YELLOW G/Y
		

REAR BRAKELIGHT SWITCH

The switch is normal if there is conductivity with the rear brake applied.

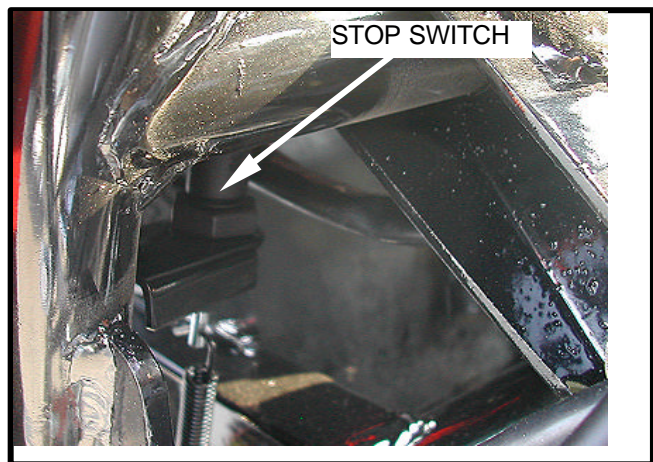

HORN

Connect the horn to a 12V battery for testing its performance. Adjust the horn if the noise is not loud enough.

