

SUZUKI

AP50

SERVICE MANUAL



99500-10432-01E

FOREWORD

This manual contains an introductory description on SUZUKI AP50 and procedures for its inspection/service and overhaul of its main components. Other information considered as generally known is not included.

Read GENERAL INFORMATION section to familiarize yourself with outline of the vehicle and MAINTENANCE and other sections to use as a guide for proper inspection and service.

This manual will help you know the vehicle better so that you can assure your customers of your optimum and quick service.

** This manual has been prepared on the basis of the latest specification at the time of publication.*

If modification has been made since then, difference may exist between the content of this manual and the actual vehicle.

** Illustrations in this manual are used to show the basic principles of operation and work procedures.*

They may not represent the actual vehicle exactly in detail.

** This manual is intended for those who have enough knowledge and skills for servicing SUZUKI vehicles. Without such knowledge and skills, you should not attempt servicing by relying on this manual only.*

Instead, please contact your nearby authorized SUZUKI motorcycle dealer.

GROUP INDEX

GENERAL INFORMATION	1
PERIODIC MAINTENANCE	2
ENGINE	3
FUEL AND LUBRICATION SYSTEM	4
CHASSIS	5
ELECTRICAL SYSTEM	6
SERVICING INFORMATION	7
AP50T ('96-MODEL)	8
AP50V ('97-MODEL)	9
AP50W ('98-MODEL)	10

SUZUKI MOTOR ESPAÑA, S. A.

HOW TO USE THIS MANUAL

TO LOCATE WHAT YOU ARE LOOKING FOR:

1. The text of this manual is divided into sections.
2. As the title of these sections are listed on the previous page as GROUP INDEX, select the section where what you are looking for belong.
3. Holding the manual as shown at the right will allow you to find the first page of the section easily.
4. On the first page of each section, its contents are listed. Find the item and page you need.

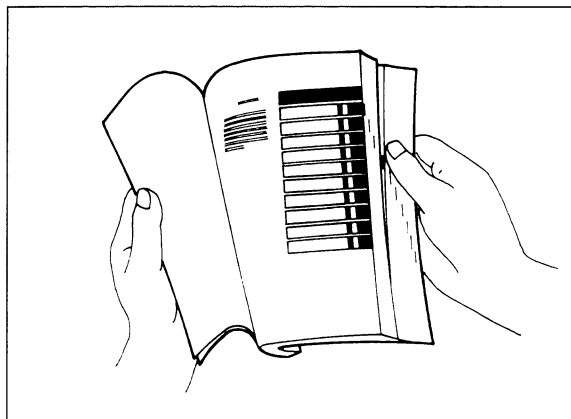

COMPONENT PARTS AND WORK TO BE DONE

Under the name of each system or unit, its exploded view is provided with work instruction and other service information such as the tightening torque, lubricating points and locking agent points.

Example: Front wheel

① Front axle
 ② Spacer
 ③ Bearing
 ④ Spacer
 ⑤ Front wheel
 ⑥ Speedometer gearbox
 ⑦ Brake disc















A

B

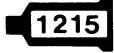
ITEM	N·m	kg-m	lb-ft
A	42	4.2	30.5
B	23	2.3	16.5

SYMBOL

Listed in the table below are the symbols indicating instructions and other information necessary for servicing and meaning associated with them respectively.

SYMBOL	DEFINITION	SYMBOL	DEFINITION
	Torque control required. Data beside it indicates specified torque.		Apply THREAD LOCK SUPER "1360" 99000-32130
	Apply oil. Use engine oil unless otherwise specified.		Apply or use brake fluid
	Apply SUZUKI SUPER GREASE "A". 99000-25010		Measure in voltage range.
	Apply SUZUKI MOLY PASTE. 99000-25140		Measure in resistance range.
	Apply SUZUKI BOND "1215". 99000-31110		Measure in current range.
	Apply THREAD LOCK "1342". 99000-32050		Use special tool.
	Apply THREAD LOCK SUPER "1322". 99000-32110		Use fork oil 99000-99044-10G

GENERAL INFORMATION

CONTENTS

WARNING/CAUTION/NOTE	1- 1
GENERAL PRECAUTIONS	1- 1
SUZUKI AP50S ('95-MODEL)	1- 3
SERIAL NUMBER LOCATION	1- 3
FUEL AND OIL RECOMMENDATION	1- 3
FUEL	1- 3
ENGINE OIL	1- 3
FINAL GEAR OIL	1- 4
BREAK-IN PROCEDURES	1- 4
INFORMATION LABELS	1- 5
SPECIFICATIONS	1- 6
COUNTRY OR AREA	1- 7

WARNING/CAUTION/NOTE

Please read this manual and follow its instructions carefully. To emphasize special information, the symbol and the words WARNING, CAUTION and NOTE have special meanings. Pay special attention to the messages highlighted by these signal words.

⚠ WARNING

Indicates a potential hazard that could result in death or injury.

⚠ CAUTION

Indicates a potential hazard that could result in vehicle damage.

NOTE:

Indicates special information to make maintenance easier or instructions clearer.

Please note, however, that the warnings and cautions contained in this manual cannot possibly cover all potential hazards relating to the servicing, or lack of servicing, of the motorcycle. In addition to the WARNINGS and CAUTIONS stated, you must use good judgement and basic mechanical safety principles. If you are unsure about how to perform a particular service operation, ask a more experienced mechanic for advice.

GENERAL PRECAUTIONS

⚠ WARNING

- * Proper service and repair procedures are important for the safety of the service mechanic and the safety and reliability of the vehicle.
- * When 2 or more persons work together, pay attention to the safety of each other.
- * When it is necessary to run the engine indoors, make sure that exhaust gas is forced outdoors.
- * When working with toxic or flammable materials, make sure that the area you work in is well-ventilated and that you follow all of the material manufacturer's instructions.
- * Never use gasoline as a cleaning solvent.
- * To avoid getting burned, do not touch the engine or exhaust system during or for a while after engine operation.
- * After servicing fuel, oil, exhaust or brake systems, check all lines and fittings related to the system for leaks.

▲ CAUTION

- * If parts replacement is necessary, replace the parts with Suzuki Genuine Parts or their equivalent.
 - * When removing parts that are to be reused, keep them arranged in an orderly manner so that they may be reinstalled in the proper order and orientation.
 - * Be sure to use special tools when instructed.
 - * Make sure that all parts used in reassembly are clean, and also lubricated when specified.
 - * When use of a certain type of lubricant, bond, or sealant is specified, be sure to use the specified type.
 - * When removing the battery, disconnect the negative cable first and then the positive cable. When reconnecting the battery, connect the positive cable first and then the negative cable, and replace the terminal cover on the positive terminal.
 - * When performing service to electrical parts, if the service procedures not require use of battery power, disconnect the negative cable of the battery.
 - * Tighten cylinder head and case bolts and nuts, beginning with larger diameter and ending with smaller diameter, from inside to outside diagonally, to the specified tightening torque.
 - * Whenever you remove oil seals, gaskets, packing, O-rings, locking washers, cotter pins, circlips, and certain other parts as specified, be sure to replace them with new ones. Also, before installing these new parts, be sure to remove any left over material from the mating surfaces.
 - * Never reuse a circlip. When installing a new circlip, take care not to expand the end gap larger than required to slip the circlip over the shaft. After installing a circlip, always ensure that it is completely seated in its groove and securely fitted.
 - * Do not use self-locking nuts a few times over.
 - * Use a torque wrench to tighten fasteners to the torque values when specified. Wipe off grease or oil if a thread is smeared with them.
 - * After reassembly, check parts for tightness and operation.
-
- * To protect environment, do not unlawfully dispose of used motor oil and other fluids: batteries, and tires.
 - * To protect Earth's natural resources, properly dispose of used vehicles and parts.

SUZUKI AP50S ('95-MODEL)



RIGHT SIDE



LEFT SIDE

*Difference between photographs and actual motorcycles depends on the markets.

SERIAL NUMBER LOCATION

The frame serial number or V.I.N. (Vehicle Identification Number) ① is stamped on the right side of the frame. The engine serial number ② is located on the end of the crankcase. These numbers are required especially for registering the machine and ordering spare parts.

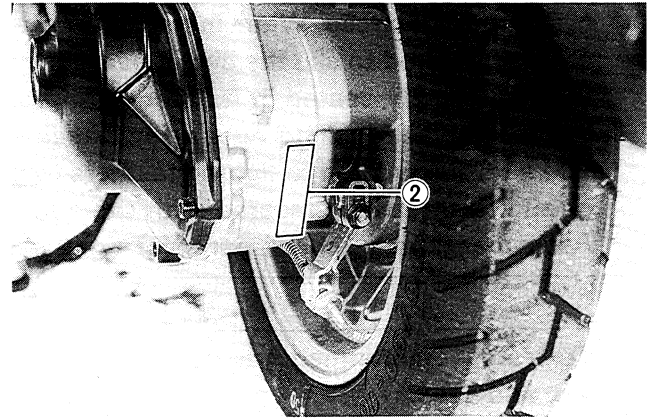
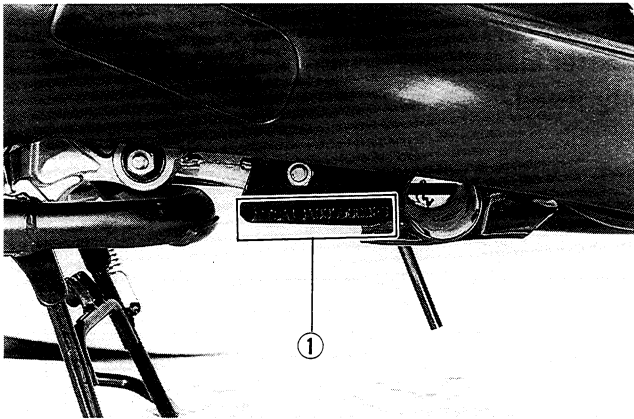

FUEL AND OIL RECOMMENDATIONS

Be sure to use the specified fuel and oils. The followings are the specifications.

FUEL

Gasoline used should be graded 85-95 octane or higher. An unleaded gasoline is recommended.

③ Fuel tank cap

ENGINE OIL

For the SUZUKI CCI system, use of SUZUKI CCI SUPER OIL is highly recommended, but if they are not available, a good quality two-stroke oil (non-diluent type) should be used.

④ Engine oil tank cap

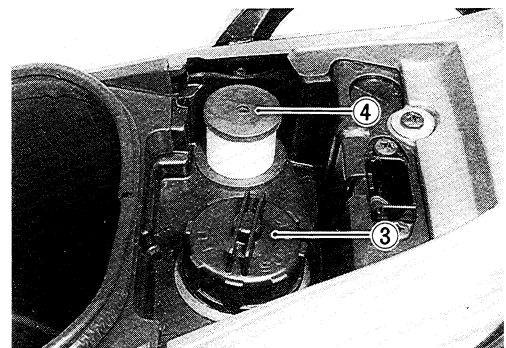

FINAL GEAR OIL

Use a good quality SAE 10W/40 multi-grade motor oil.

BRAKE FLUID



Specification and classification: DOT 4

▲ WARNING

Since the brake system of this motorcycle is filled with a glycol-based brake fluid by the manufacturer, do not use or mix different types of fluid such as silicone-based and petroleum-based fluid for refilling the system, otherwise serious damage will result.

Do not use any brake fluid taken from old or used or unsealed containers.

Never re-use brake fluid left over from a previous servicing, which has been stored for a long period.

FRONT FORK OIL

Use fork oil # 10.

BREAK-IN PROCEDURES

During manufacture only the best possible materials are used and all machined parts are finished to a very high standard but it is still necessary to allow the moving parts to "BREAK-IN" before subjecting the engine to maximum stresses. The future performance and reliability of the engine depends on the care and restraint exercised during its early life. The general rules are as follows.

- Keep to these breaking-in throttle position:

Initial 800 km : Less than $\frac{1}{2}$ throttle

Up to 1 600 km: Less than $\frac{3}{4}$ throttle

- Upon reaching an odometer reading of 1 600 km you can subject the motorcycle to full throttle operation for short periods of time.

INFORMATION LABELS

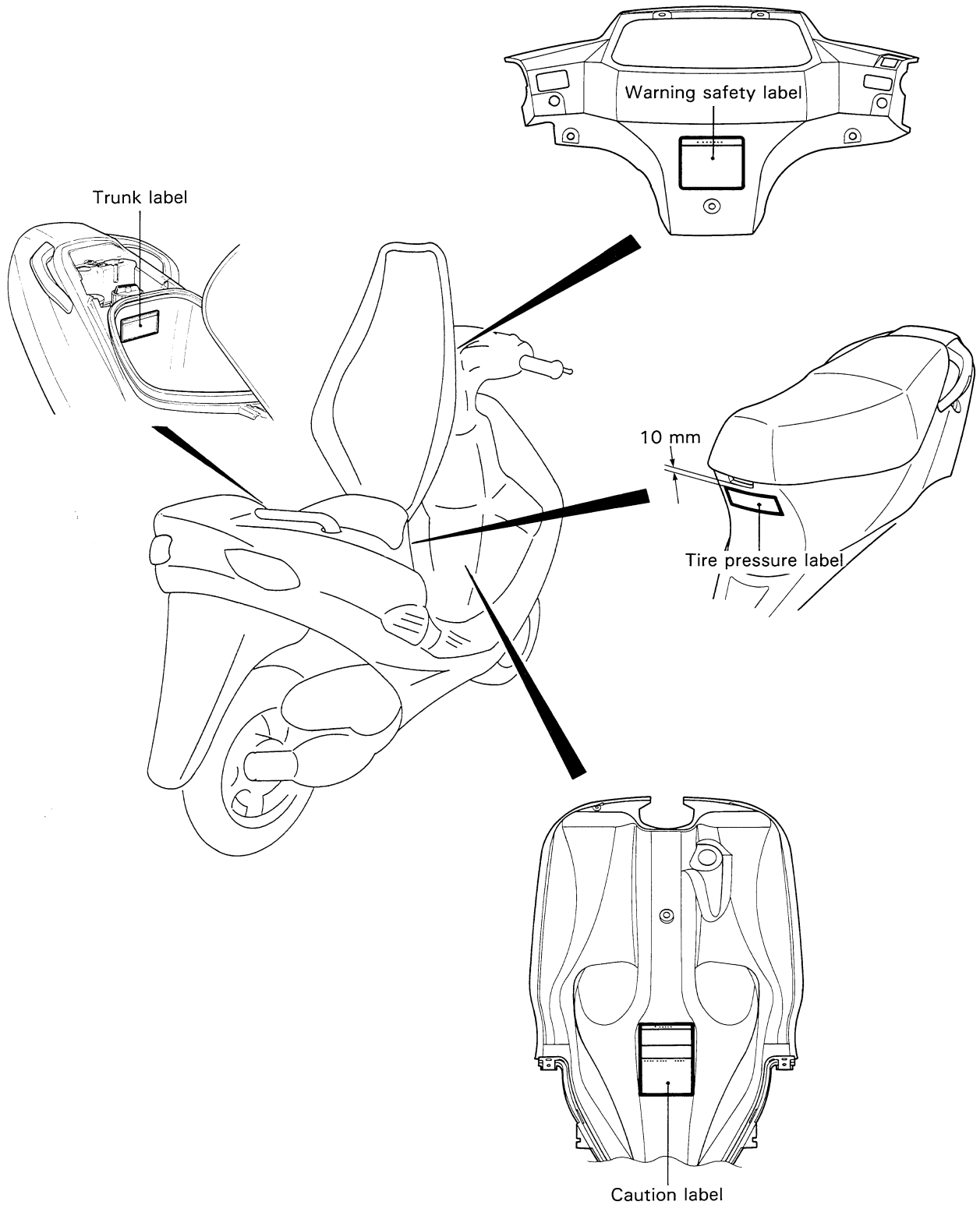

SPECIFICATIONS

DIMENSIONS AND DRY MASS

Overall length	1 715 mm (67.5 in)
Overall width	660 mm (26.0 in)
Overall height	1 065 mm (41.9 in)
Wheelbase	1 195 mm (47.0 in)
Ground clearance	125 mm (4.9 in)
Dry mass	76 kg (168 lbs)

ENGINE

Type	Two-stroke, forced air-cooled
Intake system	Reed valve
Number of cylinder	1
Bore	41.0 mm (1.614 in)
Stroke	37.4 mm (1.472 in)
Piston displacement	49 cm ³ (3.0 cu. in)
Corrected compression ratio	6.7 : 1 ... P-22 7.4 : 1 ... The others
Carburetor	MIKUNI VM12SH, single ... P-34,53 MIKUNI VM14SH, single ... The others
Air cleaner	Polyurethane foam element
Starter system	Electric and kick
Lubrication system	SUZUKI "CCI"

TRANSMISSION

Clutch	Dry shoe, automatic, centrifugal type
Gearshifting	Automatic, variable ratio
Gear ratios, variable	Variable reduction ratio (2.768—0.960) ... P-04 Variable reduction ratio (2.817—0.866) ... The others
Final reduction ratio ...	12.876 (38/11) × (41/11)
Drive system	V-belt drive

CHASSIS

Front suspension	Telescopic, coil spring, oil damped
Rear suspension	Swingarm type, coil spring, oil damped
Steering angle	45° (right & left)
Caster	65°
Trail	66 mm (2.6 in)
Turning radius	1.7 m (5.6 ft)
Front brake	Disc brake
Rear brake	Internal expanding
Front tire size	90/90-10 ... P-53 100/80-10 ... The others
Rear tire size	90/90-10 ... P-53 100/80-10 ... The others

ELECTRICAL

Ignition type	Electronic ignition (CDI)
Ignition timing	18° B.T.D.C. at 4 000 r/min
Spark plug	NGK BPR6HS, ND W20FPR or BOSCH WR7BC
Battery	12V 14.4 kC (4Ah)/10HR ... P-53 12V 10.8 kC (3Ah)/10HR ... The others
Generator	Magneto
Fuse	10A
Headlight	12V 25/25W ... P-53 12V 15W × 2 ... The others
Tail/Brake light	12V 5/21W
Turn signal light	12V 10W

CAPACITIES

Fuel tank	5.0 L (1.3/1.1 US/Imp gal)
Engine oil tank	0.8 L (0.8/0.7 US/Imp qt)
Final gear oil	90 ml (3.0/3.2 US/Imp oz)
Front fork oil	96 ml (3.2/3.4 US/Imp oz)

* These specifications are subject to change without notice.

COUNTRY OR AREA

The series of symbols on the left stand for the countries or area on the right.

SYMBOL	COUNTRY or AREA
P-04	France
P-22	Germany
P-34	Italy
P-53	Spain

PERIODIC MAINTENANCE

CONTENTS

<i>PERIODIC MAINTENANCE SCHEDULE</i>	2- 1
<i>PERIODIC MAINTENANCE CHART</i>	2- 1
<i>LUBRICATION POINTS</i>	2- 2
<i>MAINTENANCE AND TUNE-UP PROCEDURE</i>	2- 3
<i>BATTERY (For Spain)</i>	2- 3
<i>AIR CLEANER</i>	2- 4
<i>CYLINDER HEAD AND CYLINDER</i>	2- 5
<i>SPARK PLUG</i>	2- 5
<i>CARBURETOR</i>	2- 6
<i>FUEL LINE</i>	2- 6
<i>BRAKES</i>	2- 7
<i>STEERING</i>	2- 9
<i>FRONT FORK</i>	2- 9
<i>REAR SUSPENSION</i>	2-10
<i>TIRES</i>	2-10
<i>CYLINDER HEAD NUTS AND EXHAUST PIPE BOLT AND NUT</i> ...	2-11
<i>CHASSIS BOLTS AND NUTS</i>	2-11
<i>AUTOMATIC CLUTCH INSPECTION</i>	2-13

PERIODIC MAINTENANCE SCHEDULE

The chart below lists the recommended intervals for all the required periodic service work necessary to keep the motorcycle operating at peak performance and economy. Mileages are expressed in terms of kilometers and time for your convenience.

NOTE:

More frequent servicing may be performed on motorcycles that are used under severe conditions.

PERIODIC MAINTENANCE CHART

INTERVAL: This interval should be judged by odometer reading or month which comes first.	km	Initial 1 000	Every 3 000	Every 6 000
	months	2	6	12
Battery (Specific gravity of electrolyte) ... For Spain	—	I	I	I
Air cleaner	—	C	C	C
Cylinder head and cylinder	—	C	C	C
Spark plug	—	C	R	R
Carburetor	I	I	I	I
Fuel line	—	I	I	I
	Replace every 4 years			
Brakes	I	I	I	I
Brake hose	—	I	I	I
	Replace every 4 years			
Brake fluid	—	I	I	I
	Replace every 2 years			
Steering	I	I	I	I
Front fork	—	—	I	I
Rear suspension	—	—	I	I
Tires	—	I	I	I
Cylinder head nuts and exhaust pipe bolt and nut	T	T	T	T
Chassis bolts and nuts	T	T	T	T

NOTE:

I: Inspection and adjust, clean, lubricate or replace as necessary

C: Clean R: Replace T: Tighten

LUBRICATION POINTS

Proper lubrication is important for smooth operation and long life of each working part of the motorcycle.

Major lubrication points are indicated below.

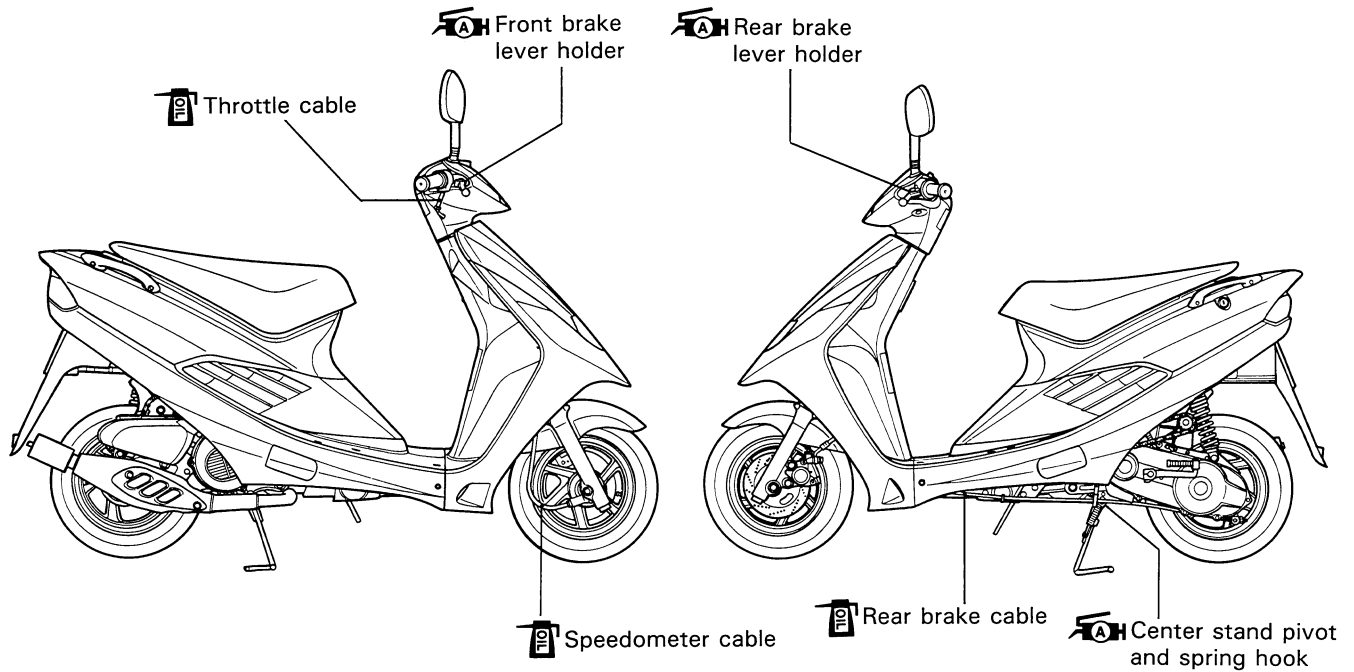

NOTE:

- * Before lubricating each part, clean off any rusty spots and wipe off any grease, oil, dirt or grime.
- * Lubricate exposed parts which are subject to rust, with a rust preventative spray when ever the motorcycle has been operated under wet or rainy condition.

MAINTENANCE AND TUNE-UP PROCEDURE

This section describes the servicing procedures for each item of the Periodic Maintenance requirements.

BATTERY (For Spain)

Inspect Every 3 000 km (6 months)

- Remove the service lid and battery cover.
- Disconnect the \ominus lead wire first and \oplus lead wire last.

Check electrolyte for level and specific gravity. Add distilled water, as necessary to keep the surface of the electrolyte above the MIN. level line but not above the MAX. level line. For checking specific gravity, use a hydrometer to determine the charged condition.

TOOL 09900-28403: Hydrometer

Standard specific gravity: 1.280 at 20°C (68°F)

An S.G. reading of 1.22 (at 20°C) or under means that the battery needs recharging. Remove the battery from the motorcycle and charge it with a battery charger.

CAUTION

- * When removing the battery from the motorcycle, be sure to disconnect the \ominus lead wire first.
- * Never charge a battery while still in the motorcycle as damage may result to the battery or regulator/rectifier.
- * Be careful not to bend, obstruct, or change the routing of the breather hose from the battery, make certain that the breather hose is attached to the battery vent fitting and that the opposite end is always open.
- * When installing the battery lead wires, fix the \oplus lead first and \ominus lead last.

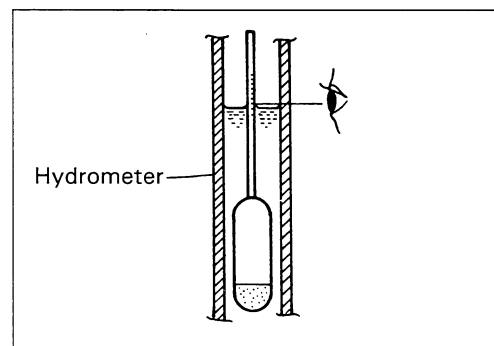
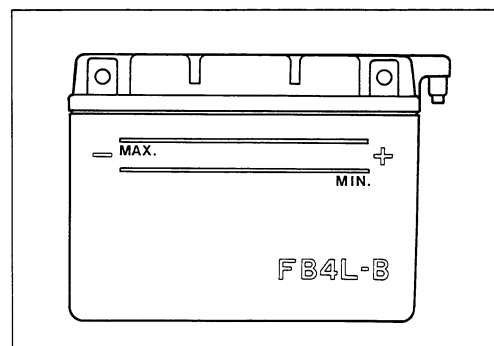
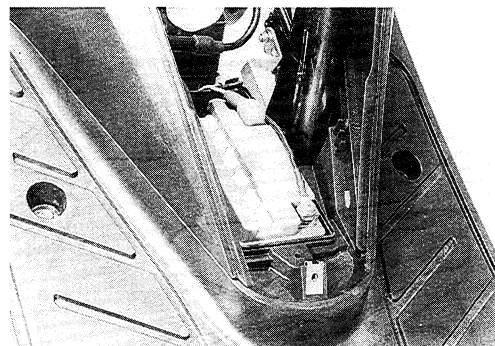

AIR CLEANER

Clean Every 3 000 km (6 months)

If the air cleaner is clogged with dust, intake resistance will be increased with a resultant decrease in power output and an increase in fuel consumption. Check and clean the element in the following manner.

- Remove the air cleaner cover by removing the sliders ① and screws ②.
- Remove the inner cover ③ and elements (④ and ⑤).
- Fill a washing pan of a proper size with non-flammable cleaning solvent. Immerse the elements in the cleaning solvent and wash them clean.
- Squeeze the cleaning solvent out of the washed element by pressing it between the palms of both hands: do not twist or wring the element or it will develop tears.
- Immerse the element in motor oil, and squeeze the oil out of the element leaving it slightly wet with oil.

⚠ CAUTION

- * Before and during the cleaning operation, inspect the element for tears. A torn element must be replaced.
- * Be sure to position the element snugly and correctly, so that no incoming air will bypass it. Remember, rapid wear of piston rings and cylinder bore is often caused by a defective or poorly fitted element.

- Ⓐ Non-flammable cleaning solvent
- Ⓑ Motor oil SAE #30 or SAE 10W/40

- Fit the elements to the cleaner case properly.

⚠ CAUTION

When fitting the cleaner elements, fit the fine mesh element first and large mesh element last.

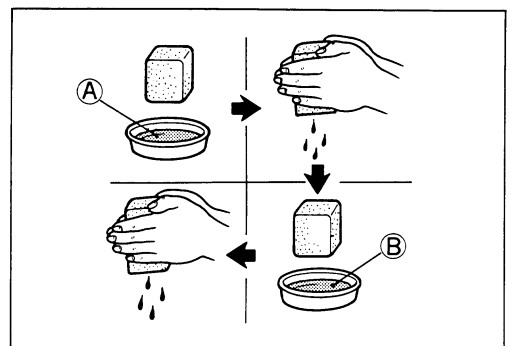
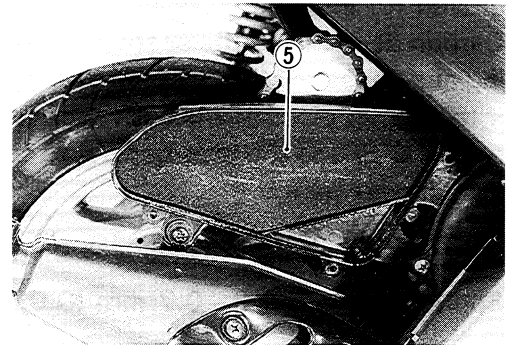
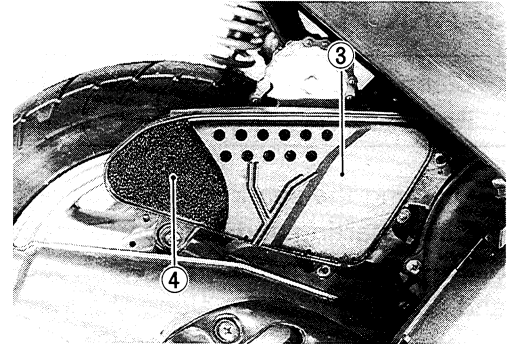
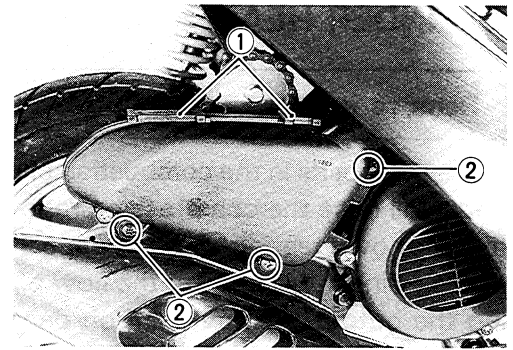

CYLINDER HEAD AND CYLINDER

Remove carbon Every 3 000 km (6 months)

Carbon deposits in the combustion chamber and the cylinder head will raise the compression ratio and may cause pre-ignition or overheating. Carbon deposited at the exhaust port of the cylinder will prevent the flow of exhaust gases, reducing the output. Remove carbon deposits periodically.

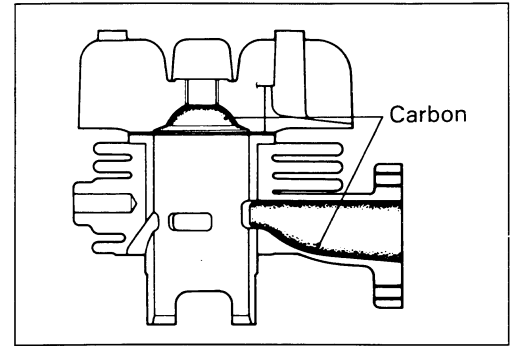

SPARK PLUG

Clean Every 3 000 km (6 months)
Replace Every 6 000 km (12 months)

Neglecting the spark plug maintenance eventually leads to difficult starting and poor performance. If the spark plug is used for a long period, the electrode gradually burns away and carbon builds up along the inside part. In accordance with the Periodic Inspection Chart, the plug should be removed for inspection, cleaning and to reset the gap. Carbon deposits on the spark plug will prevent good sparking and cause misfiring. Clean the deposits off periodically. If the center electrode is fairly worn down, the plug should be replaced and the plug gap set to the specified gap using a thickness gauge.

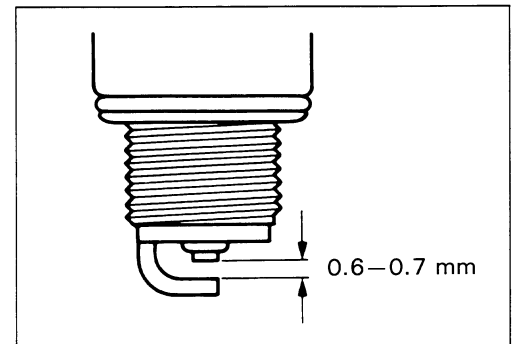
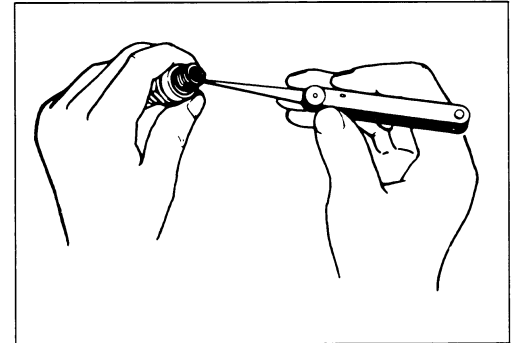

TOOL 09900-20804: Thickness gauge

Spark plug gap: 0.6–0.7 mm (0.024–0.028 in)

	NGK	NIPPONDENSO	BOSCH
STD	BPR6HS	W20FPR-U	WR7BC

- Tighten the spark plug to the specified torque.

U Spark plug: 28 N·m (2.8 kg·m, 20.0 lb·ft)

NOTE:

- * To check the spark plug, first make sure that the fuel used is unleaded gasoline, and if plug is either sooty with carbon or burnt white, replace it.
- * Confirm the thread size and reach when replacing the plug.

CARBURETOR

Inspect Initially at 1 000 km (2 months) and
Every 3 000 km (6 months)

THROTTLE CABLE PLAY

- Loosen the lock nut ① and adjust the cable play (A) by turning adjuster ② in or out to obtain the following cable play. After adjusting play, tighten the lock nut.

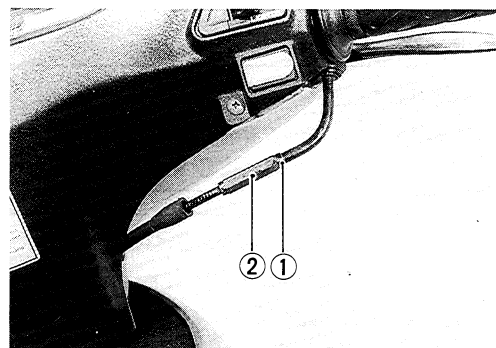

Cable play (A): 3–6 mm (0.12–0.24 in)

ENGINE IDLE R/MIN

- Adjust the throttle cable play.
- Remove the frame lower side covers. (Refer to page 5-2.)
- Warm up the engine.

NOTE:

Make this adjustment when the engine is hot.

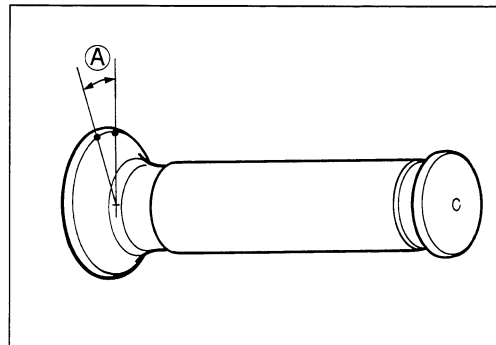

- Connect an electric tachometer to the connecting portion of the magneto lead wire as shown in the illustration. Use the selector key "C" position.

TOOL 09900-26006: Tachometer

- Adjust the throttle stop screw ③ to obtain the idle r/min as follows.

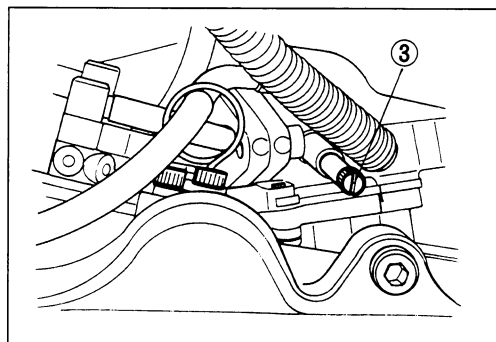

Idle r/min: 1 700 ± 200 r/min

- Finally adjust the throttle cable play.

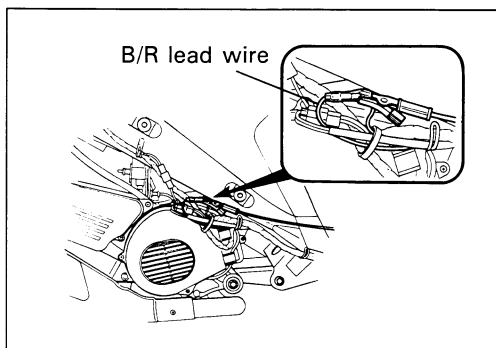

FUEL LINE

Inspect Every 3 000 km (6 months)
Replace Every 4 years

BRAKES

[BRAKE]

Inspect Initially at 1 000 km (2 months) and
Every 3 000 km (6 months)

[BRAKE HOSE AND BRAKE FLUID]

Inspect Every 3 000 km (6 months)
Replace hoses Every 4 years.
Replace fluid Every 2 years.

FRONT BRAKE FLUID LEVEL

- Keep the motorcycle upright and place the handlebars straight.
- Check the brake fluid level by observing the lower limit line on the brake fluid reservoir.
- When the level is below the lower limit line, replenish with brake fluid that meets the following specification.

 Specification and classification: DOT 4

WARNING

The brake system of this motorcycle is filled with a glycol-based brake fluid. Do not use or mix different types of fluid such as silicone-based and petroleum-based. Do not use any brake fluid taken from old, used or unsealed containers. Never re-use brake fluid left over from the last servicing or stored for a long period.

WARNING

Brake fluid, if it leaks, will interfere with safe running and immediately discolor painted surfaces. Check the brake hoses and hose joints for cracks and oil leakage before riding.

FRONT BRAKE PADS

The extent of brake pad wear can be checked by observing the limit marks ① on the pad. When the wear exceeds the limit mark, replace the pads with new ones. (Refer to page 5-9.)

CAUTION

Replace the brake pad as a set, otherwise braking performance will be adversely affected.

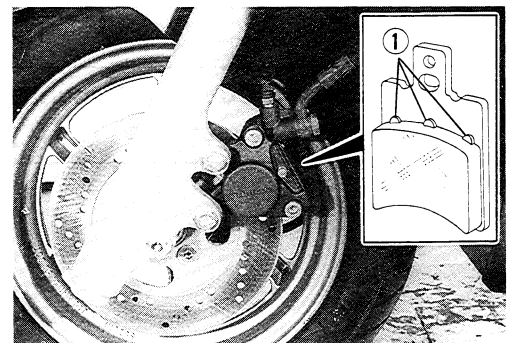
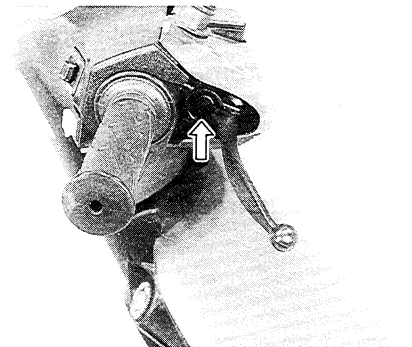

BLEEDING AIR FROM THE BRAKE FLUID CIRCUIT

Air trapped in the fluid circuit acts like a cushion to absorb a large proportion of the pressure developed by the master cylinder and thus interferes with the full braking performance of the brake caliper. The presence of air is indicated by "sponginess" of the brake lever and also by lack of braking force. Considering the danger to which such trapped air exposes the machine and rider, it is essential that, after remounting the brake and restoring the brake system to the normal condition, the brake fluid circuit be purged of air in the following manner:

- Fill up the master cylinder reservoir to the upper end of the inspection window. Replace the reservoir cap to prevent entry of dirt.
- Attach a pipe to the caliper bleeder valve, and insert the free end of the pipe into a receptacle.
- Bleed air from the bleeder valve.
- Squeeze and release the brake lever several times in rapid succession, and squeeze the lever without releasing it. Loosen the bleeder valve by turning it a quarter of a turn so that the brake fluid runs into the receptacle: this will remove the tension of the brake lever causing it to touch the handlebar grip. Then, close the valve, pump and squeeze the lever, and open the valve. Repeat this process until the fluid flowing into the receptacle no longer contains air bubbles:

NOTE:

Replenish the brake fluid reservoir as necessary while bleeding the brake system.

Make sure that there is always some fluid visible in the reservoir.

- Close the bleeder valve, and disconnect the pipe. Fill the reservoir to the upper end of the inspection window.

 Air bleeder valve: 8 N·m (0.8 kg-m, 6.0 lb-ft)

CAUTION

Handle the brake fluid with care: the fluid reacts chemically with paint, plastics, rubber materials, etc.

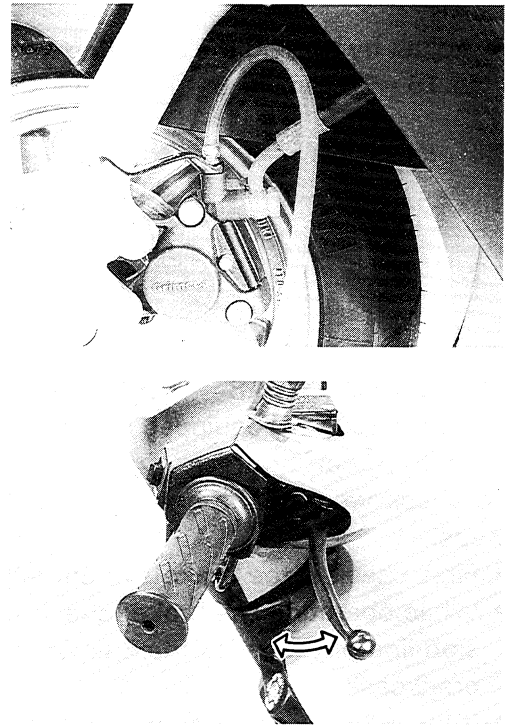

2-9 PERIODIC MAINTENANCE

REAR

- Adjust by turning the adjusting nut ① so that the play A is 15–25 mm (0.6–1.0 in) as shown in photo.

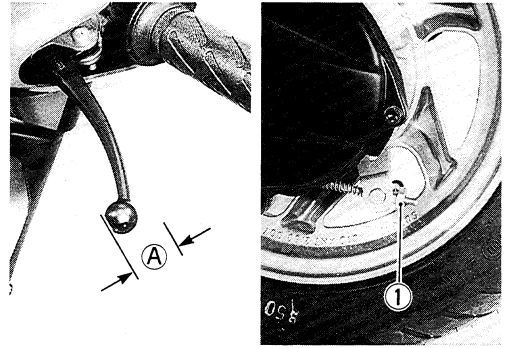

BRAKE SHOE WEAR

This motorcycle is equipped with the brake lining wear limit indicator ② on the rear.

To check wear of the brake lining, perform the following steps.

- First check if the brake system is properly adjusted.
- While operating the brake, check to see that the extension line of the index mark is within the range B on the crankcase.
- If the index mark is beyond the range, the brake shoe assembly should be replaced with a new set of shoe.

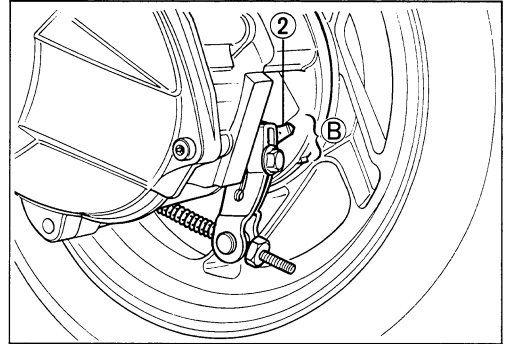

STEERING

**Inspect Initially at 1 000 km (2 months) and
Every 3 000 km (6 months)**

Steering should be adjusted properly for smooth manipulation of handlebars and safe running. Too stiff steering prevents smooth manipulation of handlebars and too loose steering will cause the handlebars to vibrate. Check to see that there is no play in the front fork and handlebars fittings. If any play is found, perform steering bearing adjustment as described in page 5-25 of this manual.



FRONT FORK

Inspect Every 6 000 km (12 months)

Inspect the front fork for oil leakage, scoring or scratches on the outer surface of inner tube. Replace the any defective parts, if necessary.

REAR SUSPENSION

Inspect Every 6 000 km (12 months)

Inspect the rear shock absorber for oil leak and bushing including engine case for wear and damage. Replace the defective part if necessary.

TIRES

Inspect Every 3 000 km (6 months)

TIRE PRESSURE

If the tire pressure is too high, the motorcycle will tend to ride stiffly and have poor traction. Conversely, if the tire pressure is too low, stability will be adversely affected. Therefore, maintain the correct tire pressure for good roadability and to prolong tire life.

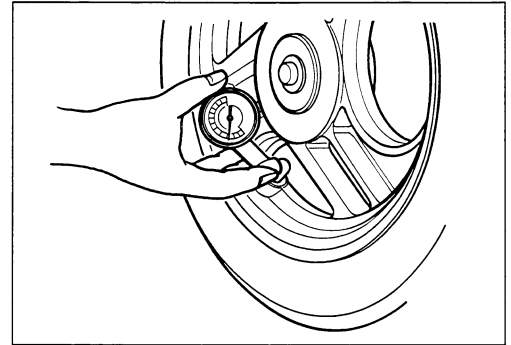

For Italy and Spain

COLD INFLATION TIRE PRESSURE	SOLO RIDING		
	kPa	kg/cm ²	psi
FRONT	125	1.25	18
REAR	175	1.75	25

For France and Germany

COLD INFLATION TIRE PRESSURE	SOLO RIDING			DUAL RIDING		
	kPa	kg/cm ²	psi	kPa	kg/cm ²	psi
FRONT	125	1.25	18	125	1.25	18
REAR	175	1.75	25	250	2.50	36

⚠ CAUTION

The standard tire fitted on this motorcycle is 90/90-10 (For Spain) or 100/80-10 (For the others) for front and rear. The use of a tire other than the standard may cause handling instability. It is highly recommended to use a SUZUKI Genuine Tire.

TIRE TREAD CONDITION

Operating the motorcycle with the excessively worn tires will decrease riding stability and consequently invite a dangerous situation. It is highly recommended to replace the tire when the remaining depth of tire tread reaches the following specification.

Front and Rear: 1.6 mm (0.06 in)

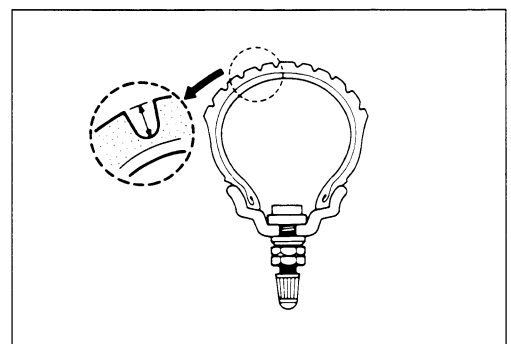

 09900-20805: Tire depth gauge

CYLINDER HEAD NUTS AND EXHAUST PIPE BOLT AND NUT

**Tighten Initially at 1 000 km (2 months) and
Every 3 000 km (6 months)**

Cylinder head nuts, when they are not tightened to the specified torque, may result in leakage of the compressed mixture and reduce output. Tighten the cylinder head nuts in the following procedure.

- Remove the lower side covers. (Refer to page 5-2.)
- Remove the spark plug cap.
- Remove the cylinder head cover.

Tighten the nuts evenly one by one in stages until each one is tightened to the specified torque.

- 🔩 **Cylinder head nut: 10 N·m (1.0 kg-m, 7.0 lb-ft)**
- 🔩 **Exhaust pipe bolt and nut: 10 N·m (1.0 kg-m, 7.0 lb-ft)**

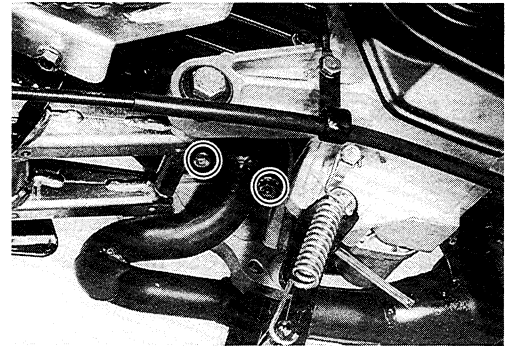
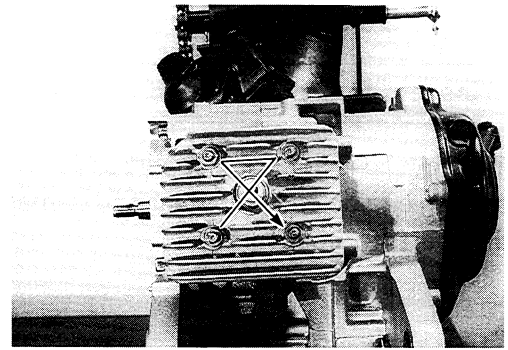

CHASSIS BOLTS AND NUTS

**Tighten Initially at 1 000 km (2 months) and
Every 3 000 km (6 months)**

Check that all chassis bolts and nuts are tightened to their specified torque.

ITEM	N·m	kg-m	lb-ft
① Front axle nut	42	4.2	30.5
② Steering stem lock nut	80	8.0	58.0
③ Handlebars set bolt	25	2.5	18.0
④ Handlebars clamp nut	49	4.9	35.5
⑤ Front fork clamp bolt	23	2.3	16.5
⑥ Front brake caliper mounting bolt	26	2.6	19.0
⑦ Front brake hose union bolt	23	2.3	16.5
⑧ Front brake caliper air bleeder valve	8	0.8	6.0
⑨ Front brake disc bolt	23	2.3	16.5
⑩ Front brake master cylinder bolt	10	1.0	7.0
⑪ Rear axle nut	42	4.2	30.5
⑫ Rear shock absorber bolt (upper)	29	2.9	21.0
⑬ Rear shock absorber nut	32	3.2	23.0
⑭ Rear brake cam lever nut	7	0.7	5.0

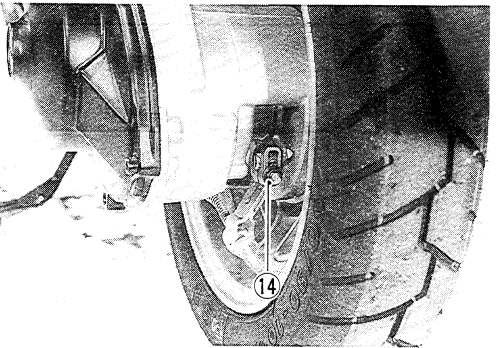
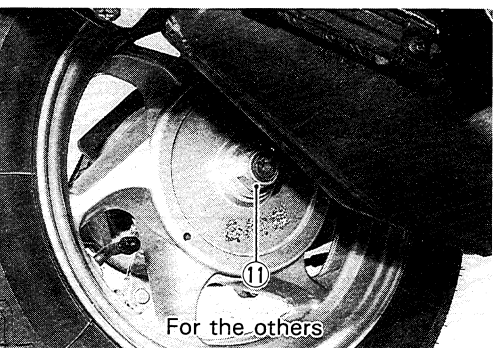
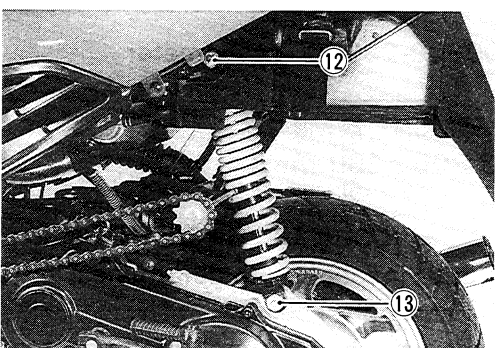
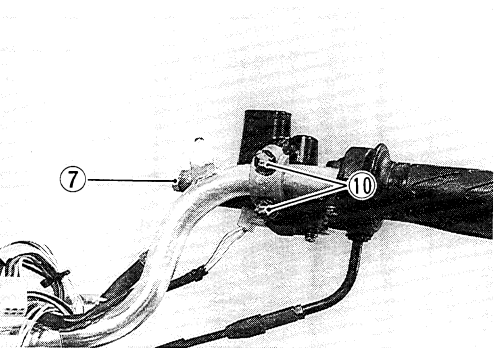
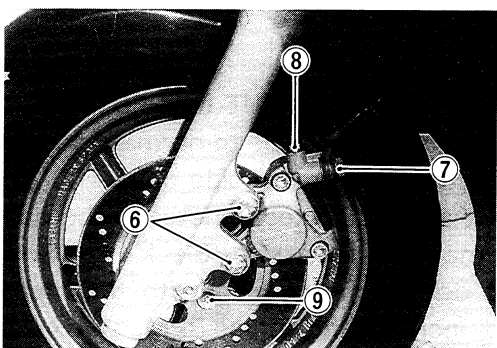
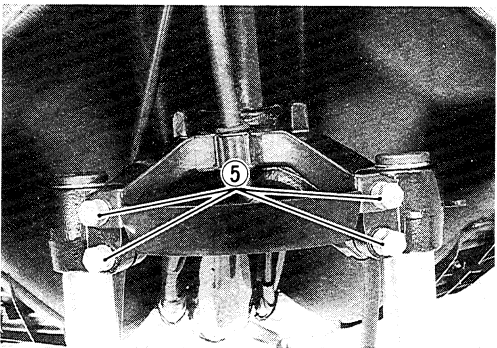
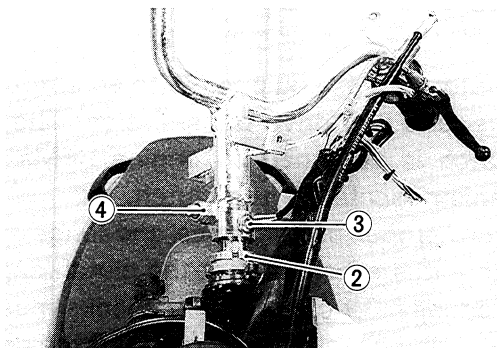
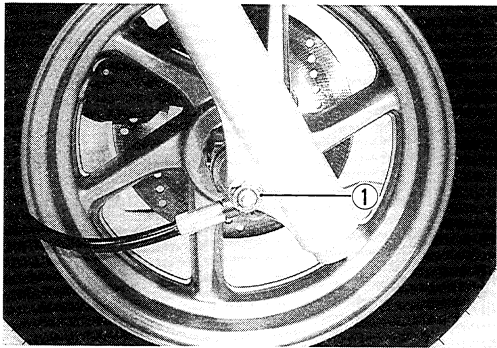

AUTOMATIC CLUTCH INSPECTION

This motorcycle is equipped with an automatic clutch and variable ratio belt drive transmission. The engagement of the clutch is governed by engine RPMs and centrifugal mechanism located in the clutch.

To insure proper performance and longevity of the clutch assembly it is essential that the clutch engages smoothly and gradually. Two inspection checks must be performed to thoroughly check the operation of the drivetrain. Follow the procedures listed.

1. INITIAL ENGAGEMENT INSPECTION

Warm up the motorcycle to normal operating temperature. Remove the right frame side cover.

Connect an electric tachometer to the connecting portion of the magneto lead wire (Black with Red tracer).

Seated on the motorcycle with the motorcycle on level ground, increase the engine RPMs slowly and note the PRM at which the motorcycle begins to move forward.

TOOL 09900-26006: Tachometer

ENGAGEMENT R/MIN

STD: 3 300 ± 200 r/min

2. CLUTCH "LOCK-UP" INSPECTION

Perform this inspection to determine if the clutch is engaging fully and not slipping.

Warm the engine to normal operating temperatures.

Connect an electric tachometer to the magneto lead wire.

Apply the rear brake as firm as possible.

Briefly open the throttle fully and note the maximum engine RPMs sustained during the test cycle.

CAUTION

Do not apply full power for more than 10 seconds or damage to the clutch or engine may occur.

LOCK-UP R/MIN

STD: 4 500 ± 300 r/min

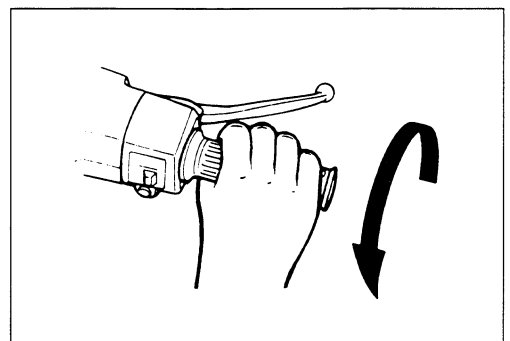
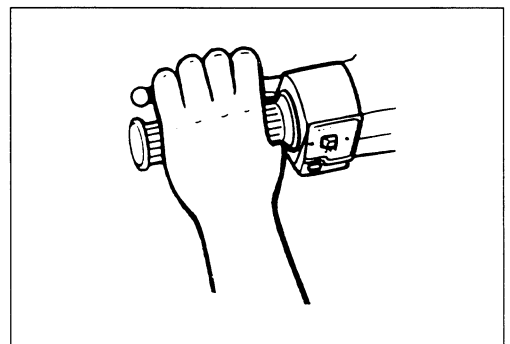
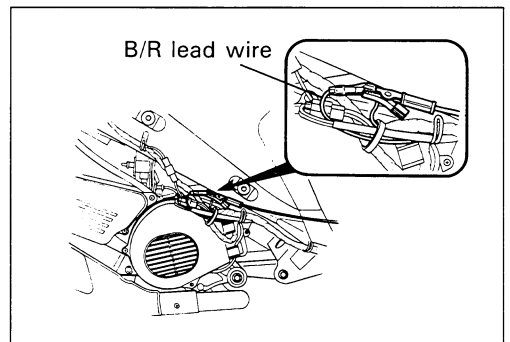

ENGINE

CONTENTS

ENGINE COMPONENTS REMOVABLE WITH THE ENGINE IN PLACE	3- 1
ENGINE REMOVAL AND REMOUNTING	3- 2
ENGINE DISASSEMBLY	3- 5
ENGINE COMPONENTS INSPECTION AND SERVICING	3-12
BEARINGS	3-12
OIL SEALS	3-12
CRANKSHAFT	3-15
CLUTCH AND MOVABLE DRIVEN	3-16
MOVABLE DRIVE	3-20
DRIVE BELT	3-21
CYLINDER HEAD	3-21
CYLINDER	3-21
PISTON	3-22
REED VALVE	3-24
ENGINE REASSEMBLY	3-25
OIL SEALS	3-25
BEARINGS	3-25
BUSHINGS	3-26
CRANKSHAFT	3-27
CRANKCASE	3-28
REAR AXLE SHAFT	3-29
TRANSMISSION	3-31
STARTER PINION AND STARTER GEAR	3-33
DRIVE BELT	3-33
MOVABLE DRIVE	3-34
KICK STARTER	3-36
PISTON	3-37
OIL PUMP DRIVEN GEAR	3-38
MAGNETO	3-38

ENGINE COMPONENTS REMOVABLE WITH ENGINE IN PLACE

The parts listed below can be removed and reinstalled without removing the engine from the frame. Refer to the page listed in this section for removal instruction.

ENGINE LEFT SIDE

Kick lever	3- 8
Clutch cover	3- 8
Kick starter	3- 8
Kick driven gear	3- 8
Fixed drive fan	3- 9
Fixed drive face	3- 9
V-belt	3- 9
Movable drive face	3- 9
Starter driven gear	3- 9
Starter pinion	3- 9
Clutch housing	3- 9
Gear box cover	3-10
Mission gear.....	3-10
Clutch shoe	3-16

ENGINE CENTER

Intake pipe	3- 5
Reed valve	3- 5
Oil pump	3- 5
Cylinder head	3- 7
Cylinder	3- 7
Piston	3- 7
Oil pump driven gear	3- 8

ENGINE RIGHT SIDE

Air cleaner	3- 5
Muffler	3- 5
Cooling fan	3- 6
Magneto	3- 6
Starter motor	3- 8

ENGINE REMOVAL AND REMOUNTING

ENGINE REMOVAL

Before taking the engine out of the frame, thoroughly clean the engine with a suitable cleaner. The procedure of engine removal is sequentially explained as follows.

- Remove the right and left lower side covers. (Refer to page 5-2.)
- Remove the foot-pedal drive chain ①. (For Spain)

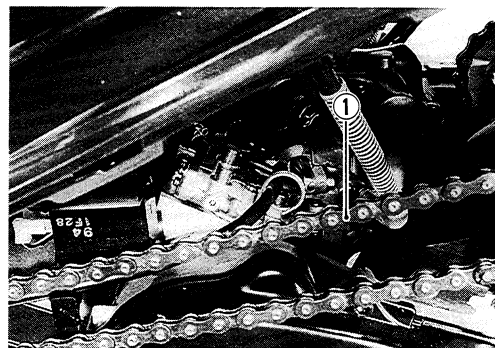

- Disconnect the fuel hose ② and vacuum hose ③ and oil hose ④.

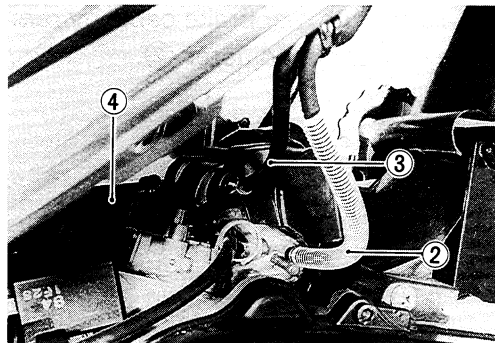

- Remove the rubber cover ⑤ from the hook of the intake pipe.

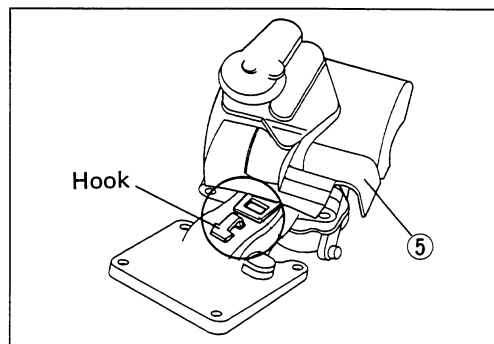

- Remove the throttle lever cover ⑥.
- Remove the throttle cable ⑦ by disconnecting the inner wire ⑧.

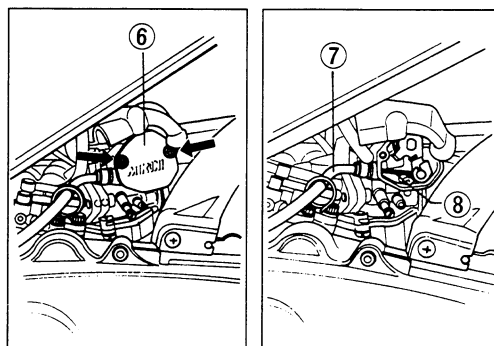

- Disconnect the ignition coil lead wires ⑨ and ground wire ⑩.

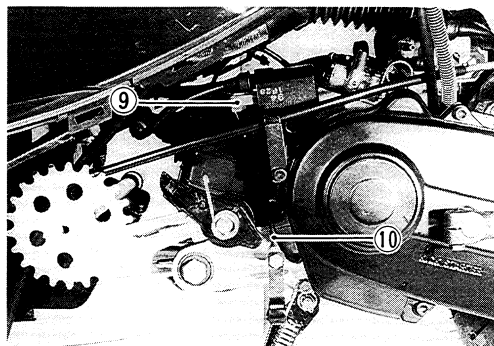

3-3 ENGINE

- Disconnect the magneto and starter motor lead wire couplers.
- Disconnect the carburetor thermo-element lead wire coupler.

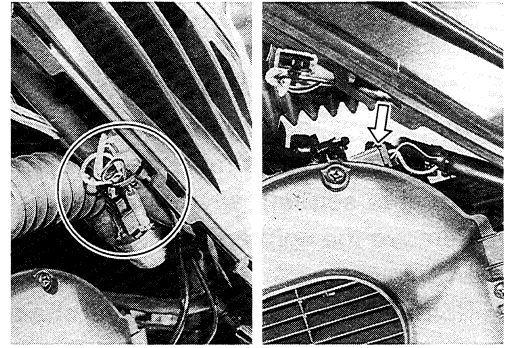

- Remove the rear brake cable by removing the cable holder ① and cable adjuster ②.

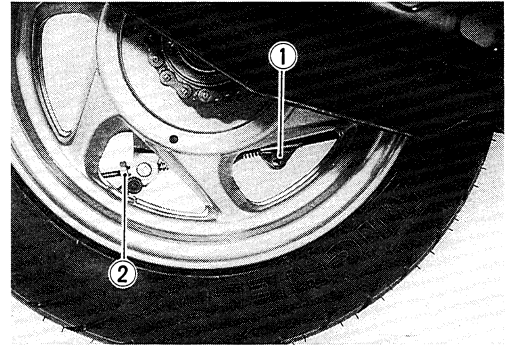

- Disconnect the air cleaner intake boot by loosening the clamp screw.

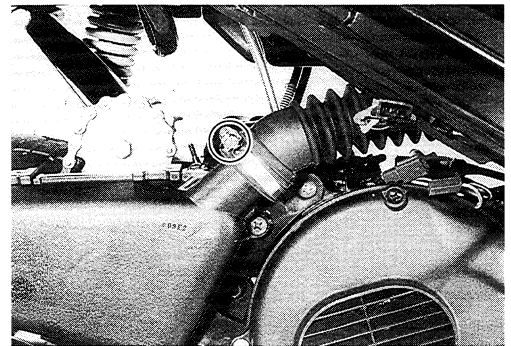

- Remove the rear shock absorber lower mounting bolt.

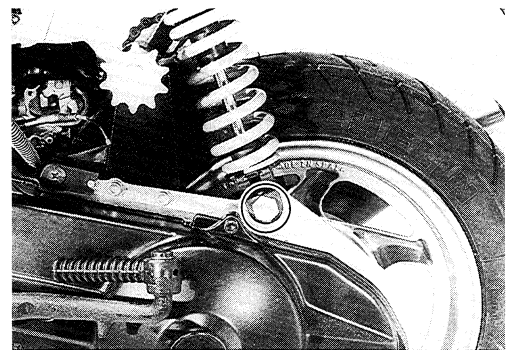

- Remove the engine by removing the engine mounting nut and shaft.

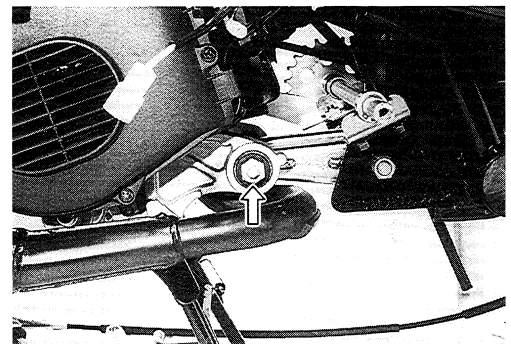

ENGINE REMOUNTING

The engine can be mounted in the reverse order of removal.

- Install the crankcase bracket ① to the frame and insert the shaft ②.
- Lift the rear part of crankcase bracket and touch the damper ③ to the stopper ④ as shown in the illustration and while holding it, tighten the nut to the specified torque.

 **Engine mounting bracket nut : 60 N·m
(6.0 kg-m, 43.5 lb-ft)**

- Install the engine and tighten the engine mounting nut ⑤ to the specified torque.

 **Engine mounting nut : 60 N·m (6.0 kg-m, 43.5 lb-ft)**

NOTE:

When tightening the engine mounting nut, keep the front wheel off the ground by supporting the machine.

- Tighten the rear shock absorber nut ⑥ to the specified torque.

 **Rear shock absorber nut: 32 N·m (3.2 kg-m, 23.0 lb-ft)**

- Place 65 kg (143 lbs) weight on the seat after remounting the engine.
- Check the clearances ① and ② (in illustration) are equal. If the clearances ① and ② are not equal, repeat the engine remounting as above procedures.

- After remounting the engine, route the wiring harness and cable properly by referring to the sections, wire routing and cable routing. (Refer to pages 7-11 through 7-17.)
- Adjust the following items to the specification.

	Page
* Throttle cable play	2- 6
* Idling adjustment	2- 6
* Rear brake cable adjustment	2- 9
* Air bleeding at oil pump	4- 9

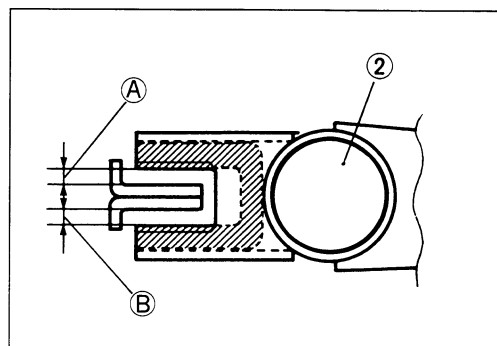
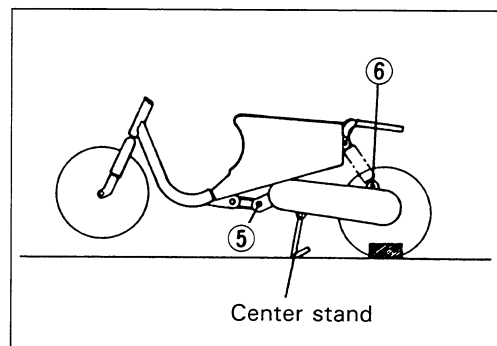
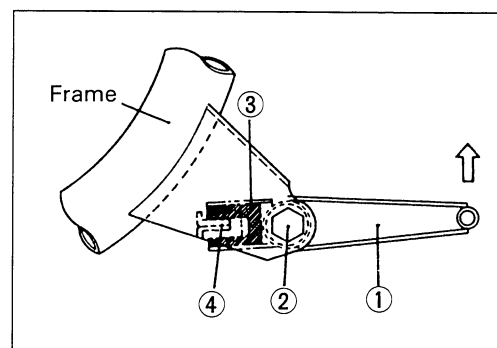

ENGINE DISASSEMBLY

- Remove the air cleaner by removing the mounting screws and carburetor intake clamp screw ①.

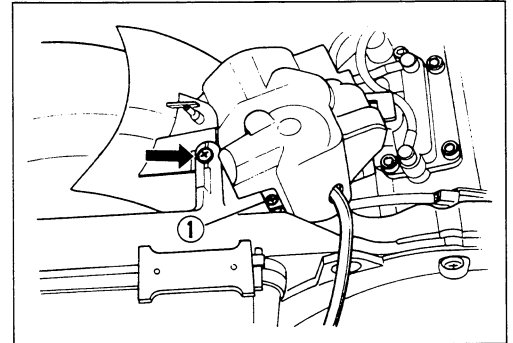
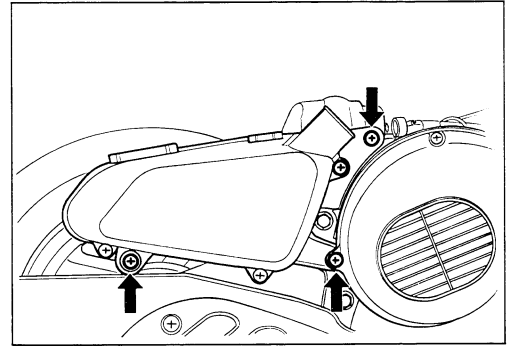

- Remove the muffler by removing the mounting bolt and nut.

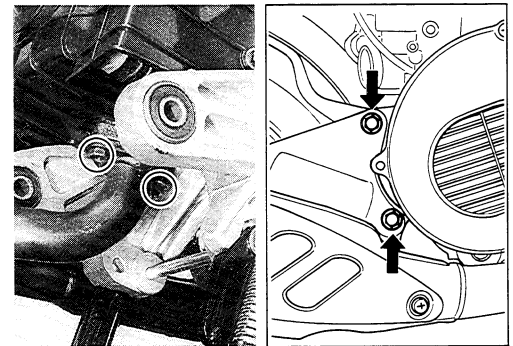

- Disconnect the oil pipes.
- Remove the oil pump.

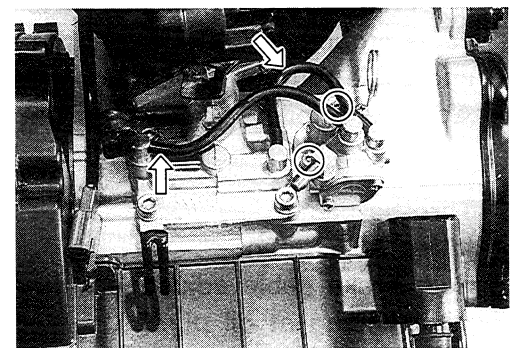

- Remove the intake pipe with the carburetor and reed valve.

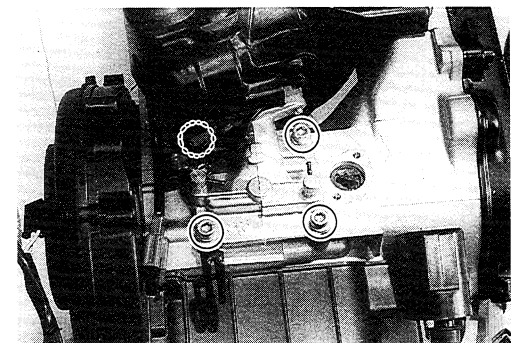

- Remove the cooling fan cover.

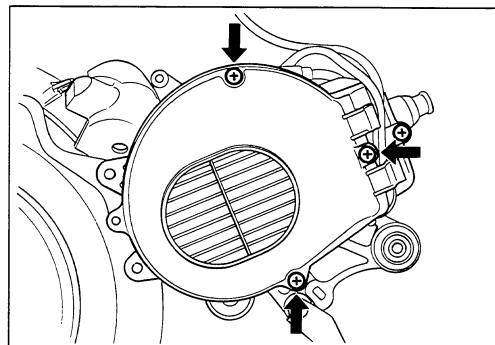

- Remove the cooling fan.

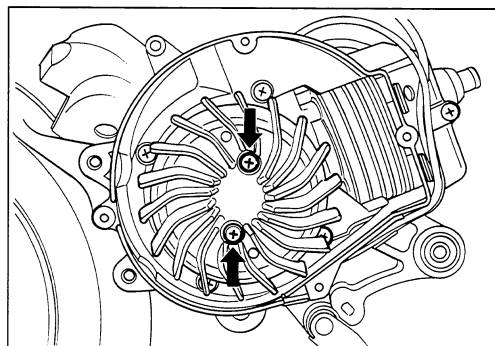

- Remove the cooling fan case.

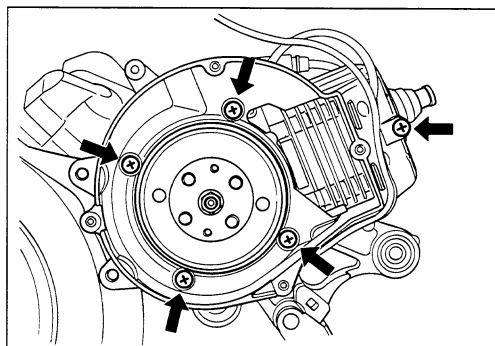

- Remove the magneto rotor nut with the special tool.

 **09930-40113: Rotor holder**

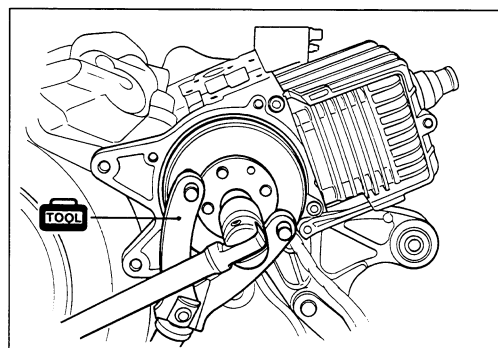

- Remove the rotor with the special tool.

 **09920-13120: Rotor remover
(Crankcase separating tool)**

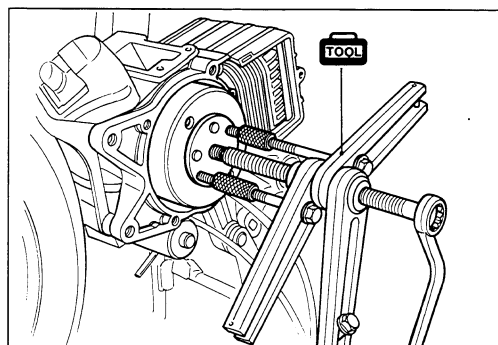

3-7 ENGINE

- Remove the stator and key ①.

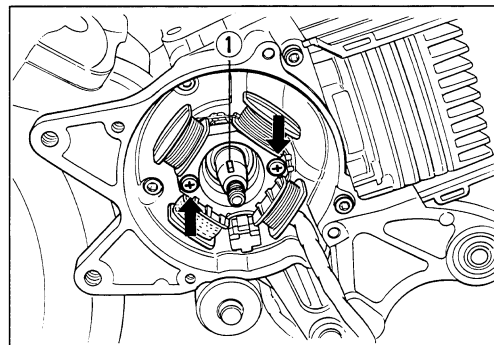

- Remove the ignition coil and cylinder cowling cover.

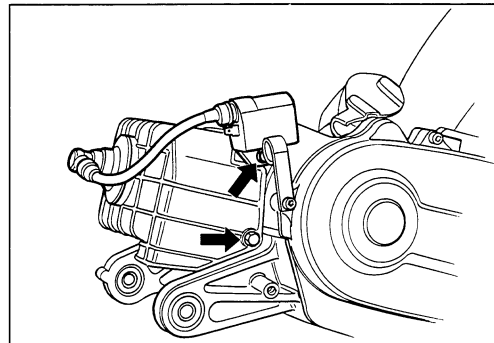

- Remove the cylinder head.

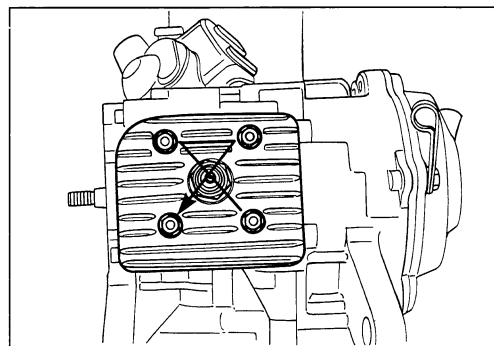

- Remove the cylinder.

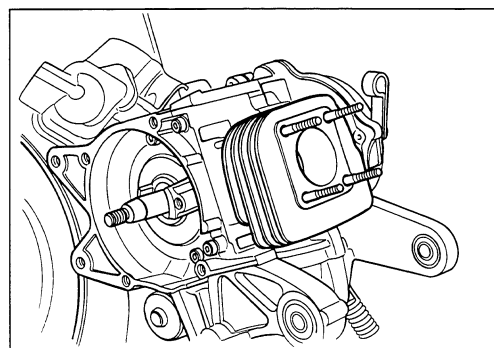

- Place a cloth beneath the piston and remove the circlip with a long-nose pliers.
- Remove the piston pin and piston.

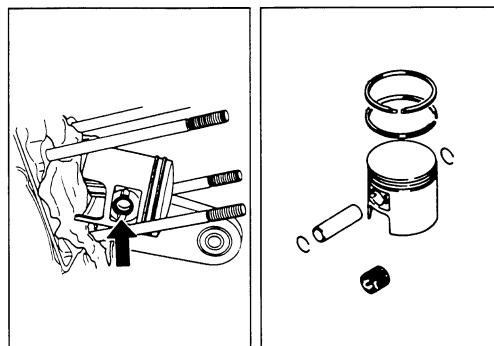

- Remove the oil pump driven gear.

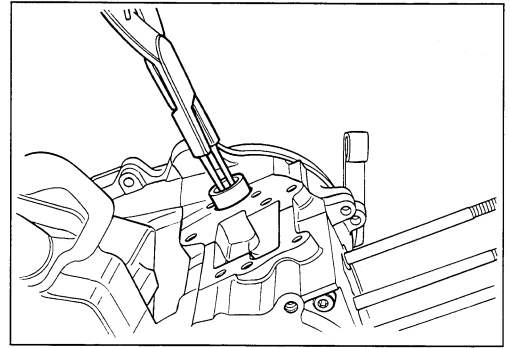

- Remove the starter motor.

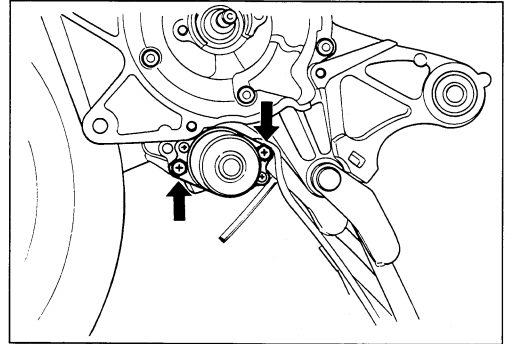

- Remove the kick starter lever.
- Remove the clutch cover.

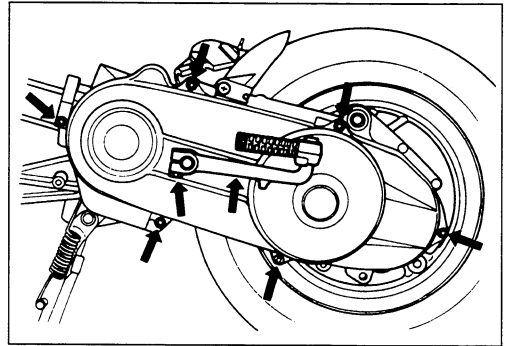

- Remove the kick starter shaft spring ① and kick starter shaft ②.

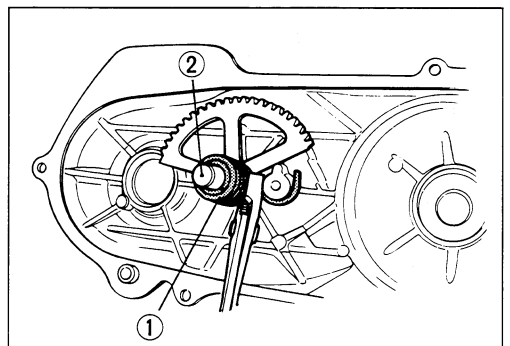

- Remove the E-ring ③, spacer ④, spring ⑤, kick driven gear ⑥ and left kick starter ⑦.

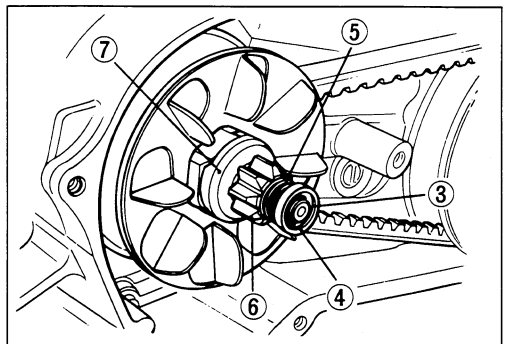

3-9 ENGINE

- Remove the kick starter nut with the special tool.

TOOL 09910-20116: Conrod holder

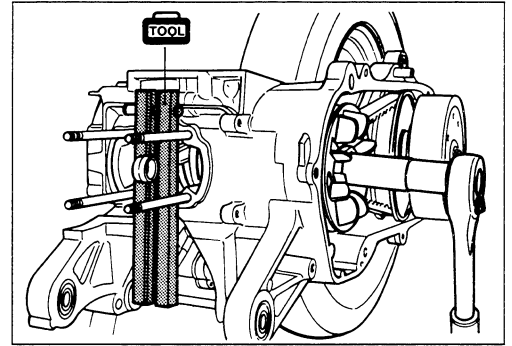

- Remove the right kick starter ①, fan ② and fixed drive face ③.
- Disassemble the movable drive face ④.

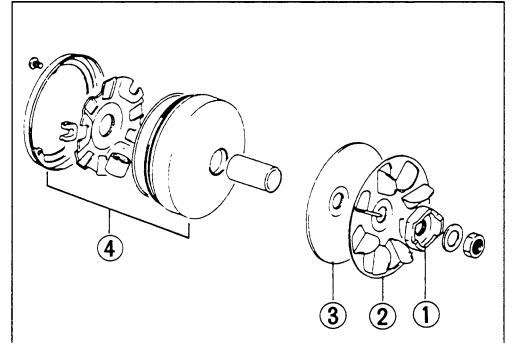

- Remove the starter driven gear.

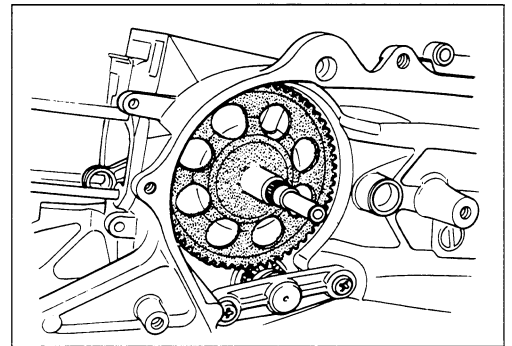

- Remove the starter idle gear cap and starter pinion.

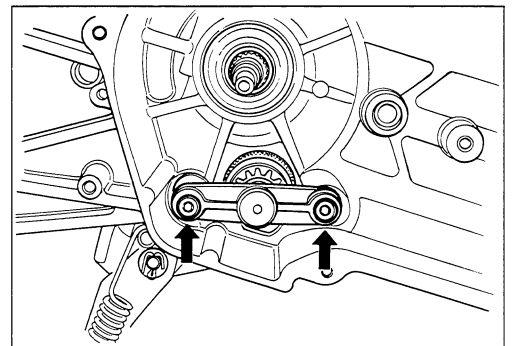

- Remove the clutch housing with the special tool.

TOOL 09930-40113: Rotor holder

- Remove the clutch shoe assembly and drive belt.
- Disassemble the clutch shoe. (Refer to page 3-16.)

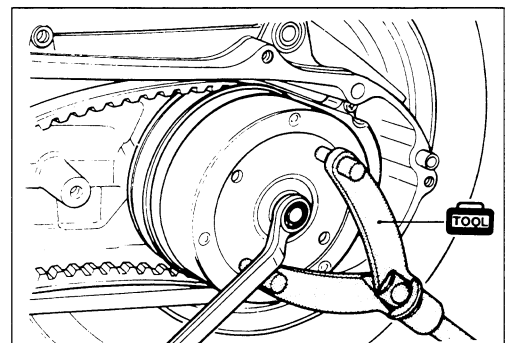

- Drain gear oil.
- Remove the gear box cover.

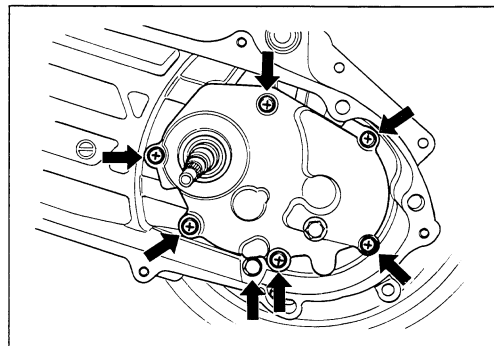

- Remove the driveshaft ①.

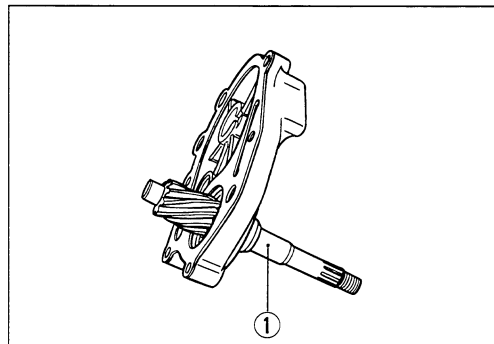

- Remove the circlip ② and final driven gear ③.
- Remove the idle shaft ④.

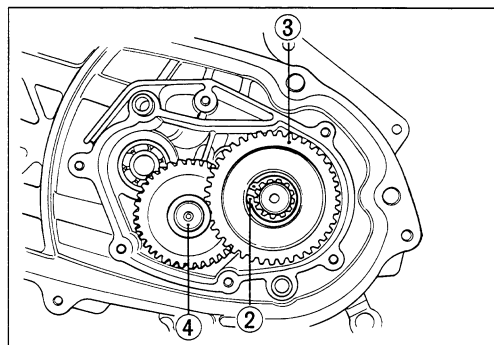

- Remove the fender with carburetor rubber cover.

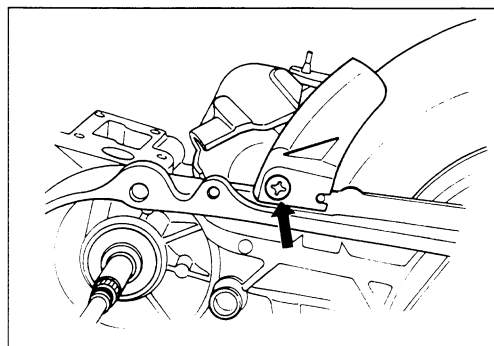

- Remove the rear wheel.

Ⓐ ... For Spain

Ⓑ ... For the others

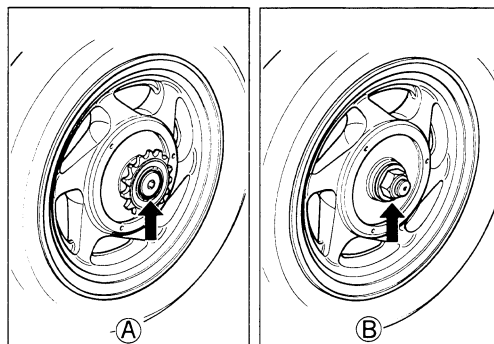

3-11 ENGINE

- Remove the brake shoe ① and rear axle shaft ②.

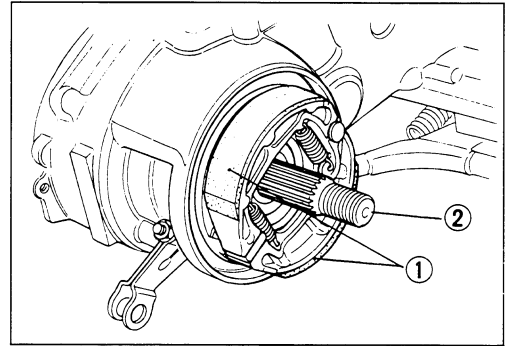

- Remove the rear brake cam lever ③, indicator plate ④ and camshaft ⑤.

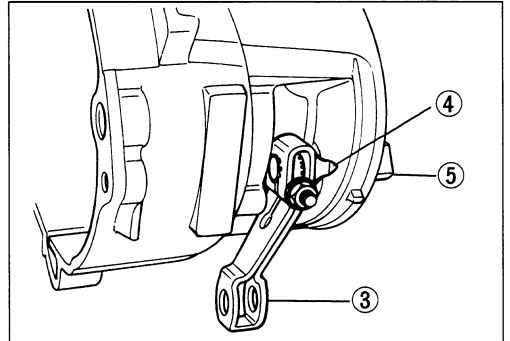

- Remove the return spring ⑥.
- Remove the cotter pin ⑦ and shaft ⑧.
- Remove the center stand ⑨.

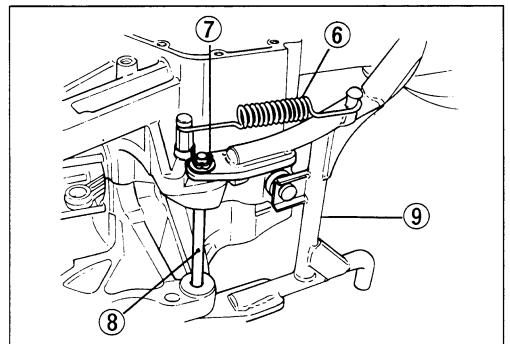

- Remove the crankcase securing screws.

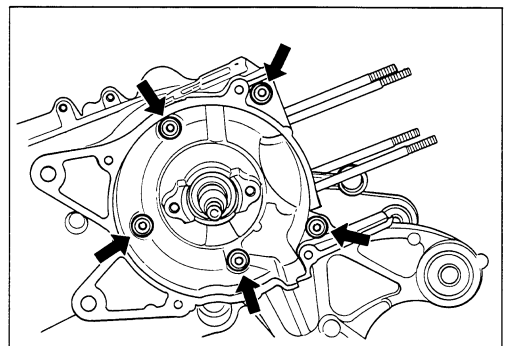

- Separate the crankcase with the special tool.

 09920-13120: Crankcase separating tool

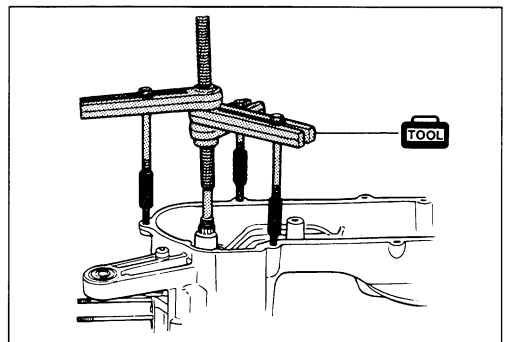

- Remove the crankshaft with the special tool.

TOOL 09920-13120: Crankshaft remover
(Crankcase separating tool)

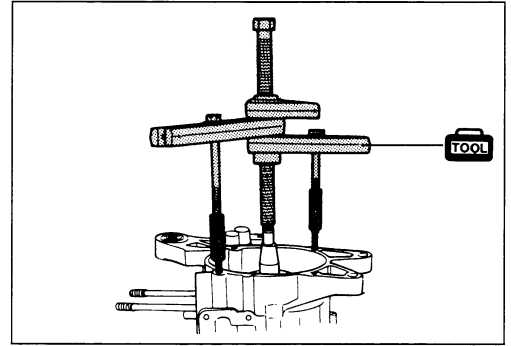

ENGINE COMPONENTS INSPECTION AND SERVICING

BEARINGS

Inspect the play of bearing inner ring by hand while mounted in the crankcase and gear box cover.

Rotate the inner ring by hand to inspect if any abnormal noise occurs or rotates smoothly.

Replace the bearing if there is anything unusual.

NOTE:

Wash the bearing with cleaning solvent and lubricate with motor oil before inspecting.

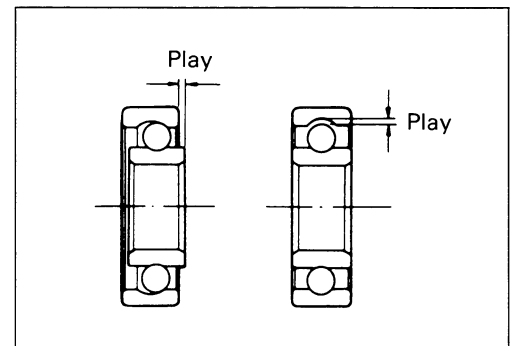

OIL SEALS

Damage to the lip of the oil seal may result in leakage of the fuel-air mixture or oil. Inspect for damage and be sure to replace the damaged seal if found.

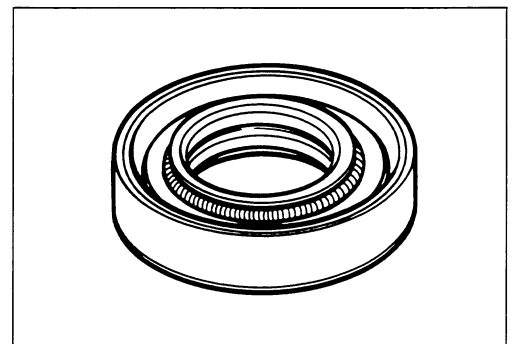

- Remove the oil seal from the gear box cover with the special tool.

TOOL 09913-50121: Oil seal remover

CAUTION

The removed oil seal should be replaced with a new one.

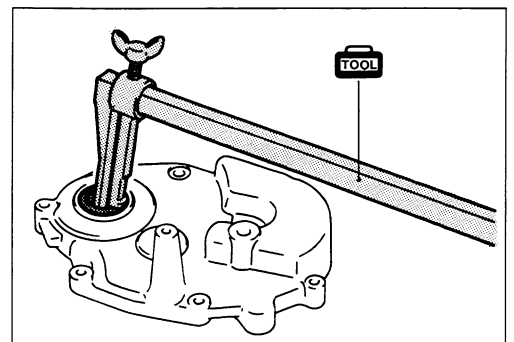

3-13 ENGINE

- Remove the bearing with the special tool.

 **09943-88211: Bearing remover
(Bearing installer)**

CAUTION

The removed bearing should be replaced with a new one.

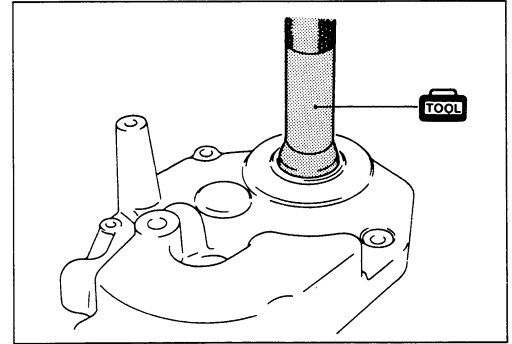

- Remove the bearing retainer.

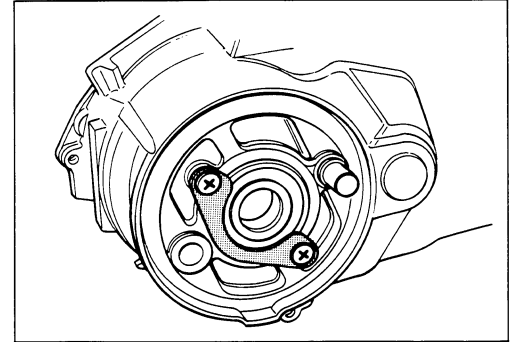

- Remove the oil seal with the special tool.

 **09913-50121: Oil seal remover**

CAUTION

The removed oil seal should be replaced with a new one.

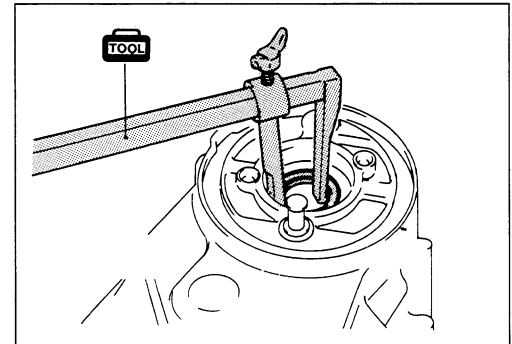

- Remove the rear axle shaft bearing with the special tool.

 **09943-88211: Bearing remover
(Bearing installer)**

CAUTION

The removed bearing should be replaced with a new one.

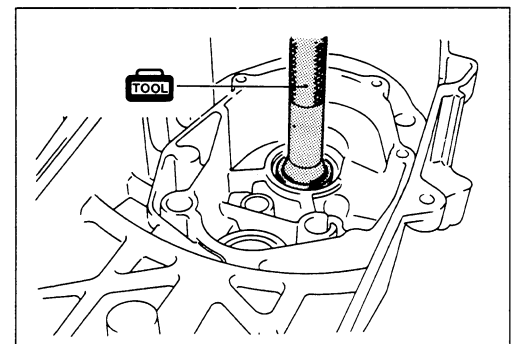

- Remove the driveshaft bearing and idle shaft bearing with the special tools.

 **09921-20210: Bearing remover**
09930-30102: Sliding shaft

CAUTION

The removed bearings should be replaced with new ones.

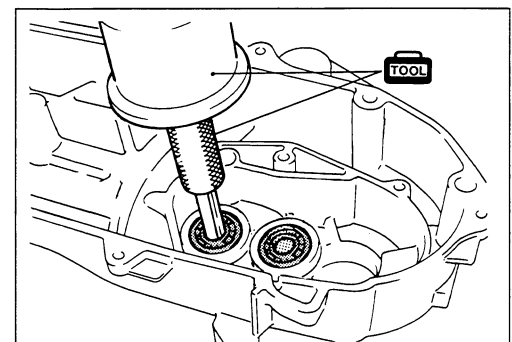

- Remove the crankshaft bearings with the special tools.

TOOL 09943-88211: Bearing remover (Bearing installer)
09913-75821: Bearing remover (Bearing installer)

CAUTION

The removed bearings should be replaced with new ones.

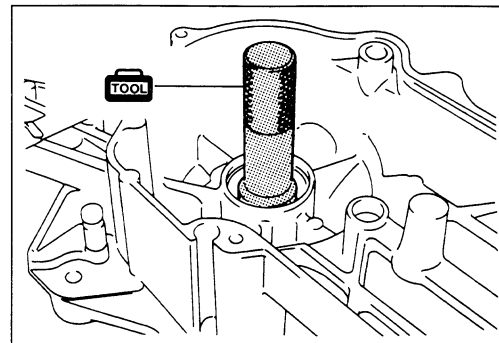
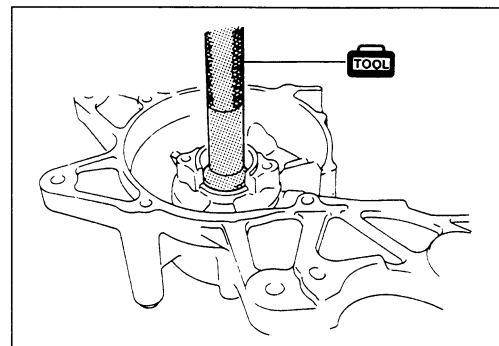

- Using two steel tubes of appropriate size, press out the engine mounting bushings on a vise as shown in the illustration.

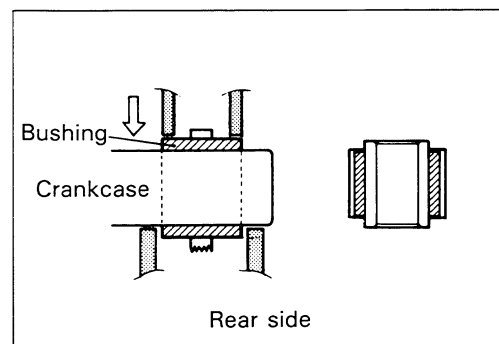
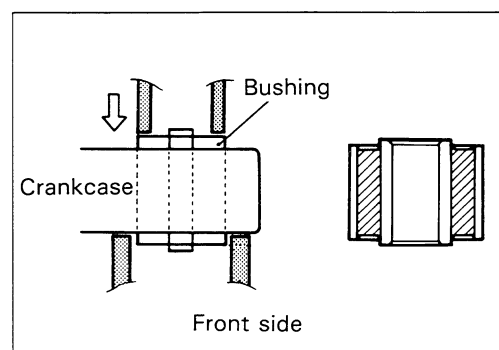
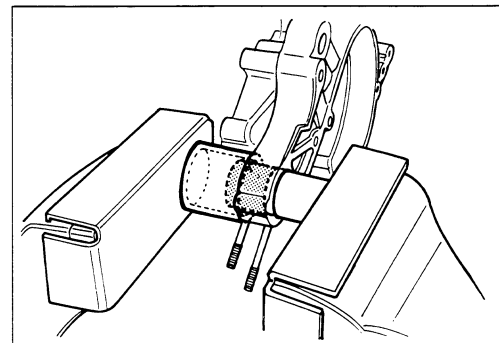

CRANKSHAFT

CRANKSHAFT RUNOUT

Support crankshaft by V-blocks, with the dial gauge rigged to read the runout as shown.

Service Limit: 0.05 mm (0.002 in)

Excessive crankshaft runout is often responsible for abnormal engine vibration. Such vibration shortens engine life.

-  **09900-21304: V-block (100 mm)**
- 09900-20701: Magnetic stand**
- 09900-20606: Dial gauge (1/100 mm)**

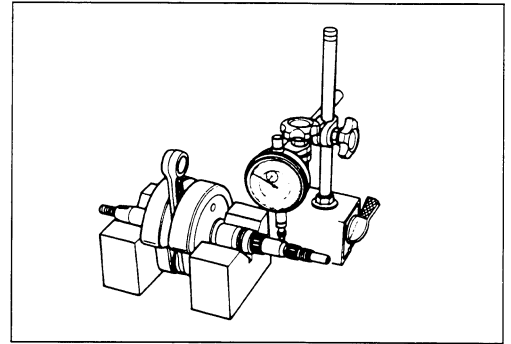

CONDITION OF BIG END BEARING

Turn the crankshaft with the conrod to feel the smoothness of rotary motion in the big end. Move the rod up and down while holding the crankshaft rigidly to be sure that there is no rattle in the big end.

Wear on the big end of the conrod can be estimated by checking the movement of the small end of the rod. This method can also check the extent of wear on the parts of the conrod's big end.

If wear exceeds the limit, conrod, crank pin and crank pin bearing should all be replaced.

Service Limit: 3.0 mm (0.12 in)

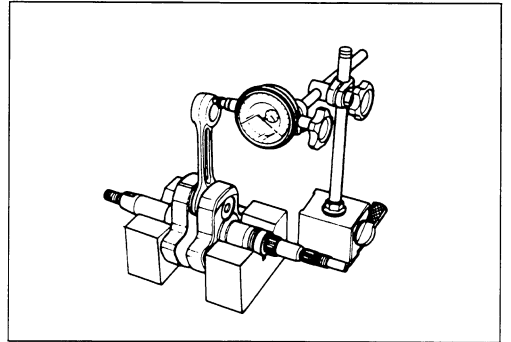

CONROD SMALL END I.D.

Measure the conrod small end diameter with a caliper gauge.

Service Limit 14.040 mm (0.5528 in)

-  **09900-20605: Dial calipers**

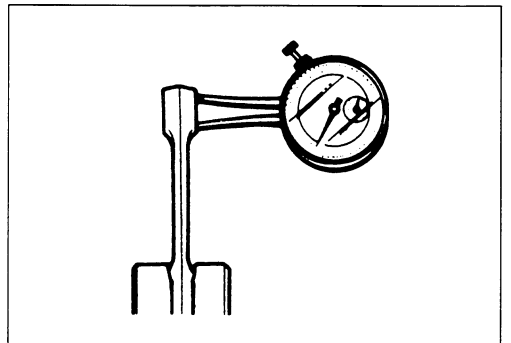

CLUTCH AND MOVABLE DRIVEN

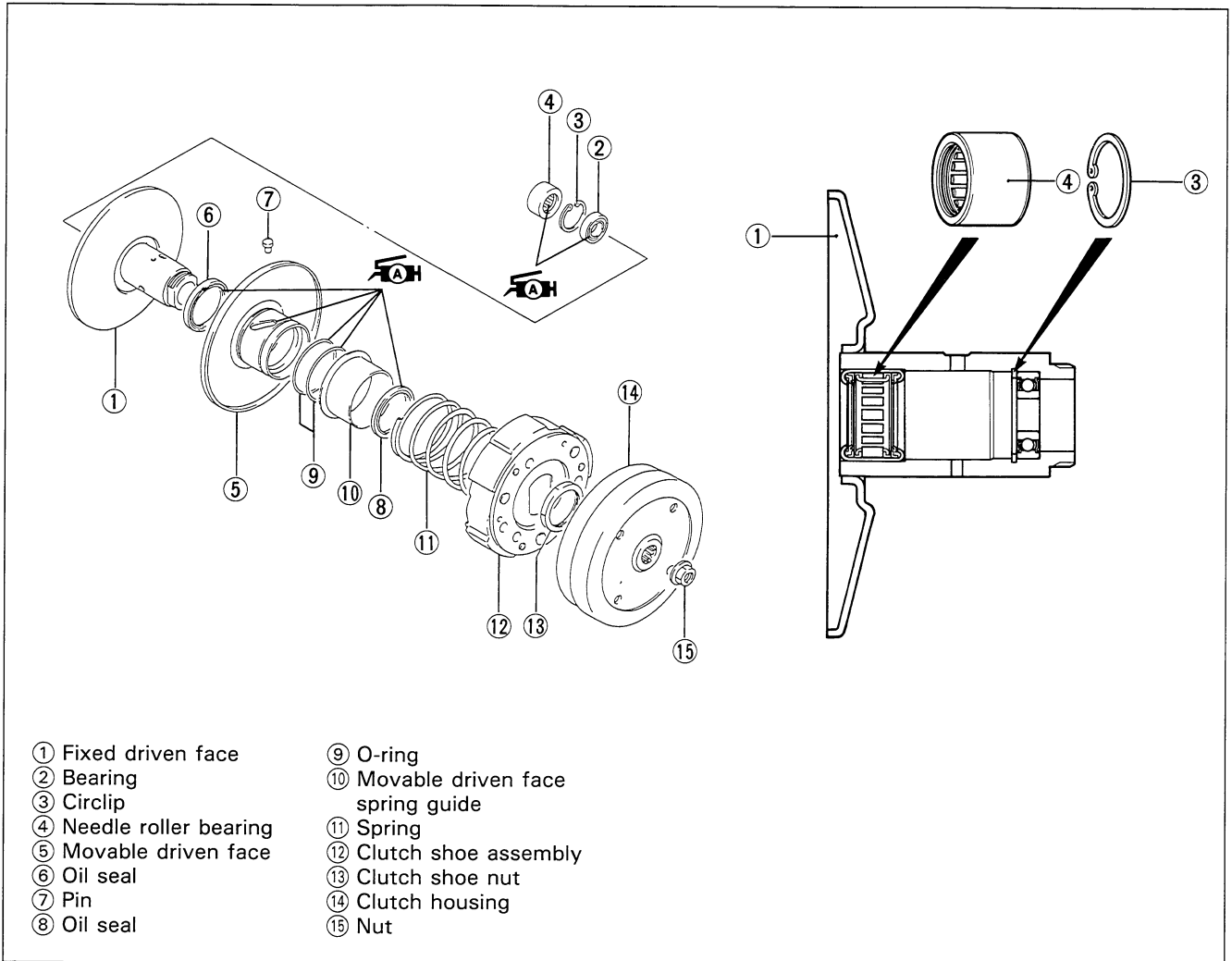

DISASSEMBLY

If the engine rpm does not coincide with the specified rpm range, then disassemble the clutch and movable driven as follows.

- Loosen the clutch shoe nut with the special tool.

TOOL 09930-40113: Rotor holder

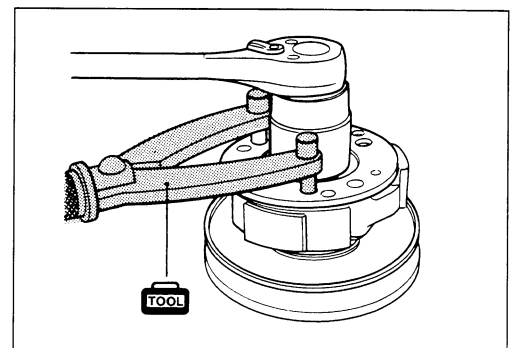

- Remove the nut while holding down the clutch shoe assembly by hand as shown in the illustration.

⚠ WARNING

Gradually back off the clutch shoe assembly pressed down by hand to counter the clutch spring load. Releasing the hand suddenly may cause the parts to fly apart.

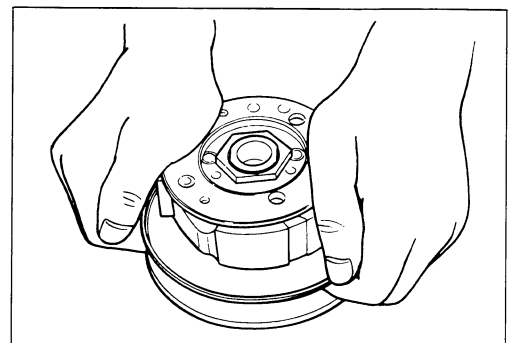

3-17 ENGINE

- ① Nut
- ② Clutch shoe assembly
- ③ Spring

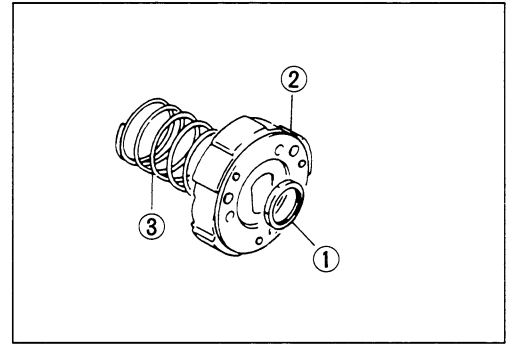

- Using a thin blade screwdriver or the like, pry up the movable driven face spring guide.

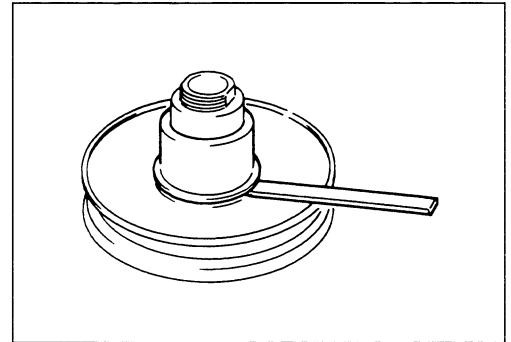

- Remove the pins ④, movable driven face ⑤ and fixed driven face ⑥.

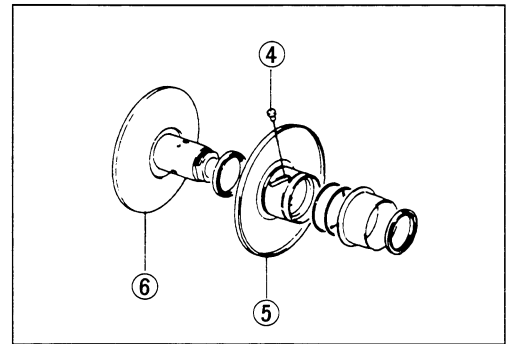

- Remove the bearing with the special tools.

TOOL 09923-73210: Bearing remover
09930-30102: Sliding shaft

CAUTION

The removed bearing should be replaced with a new one.

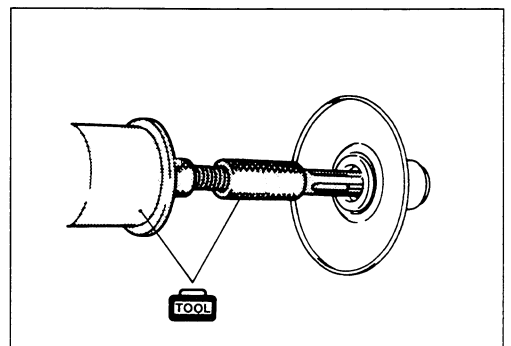

- Remove the circlip.

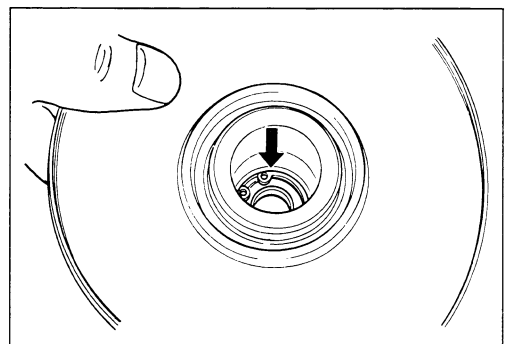

- Remove the bearing with the special tool.

 09941-50111: Bearing remover

CAUTION

The removed bearing should be replaced with a new one.

- Remove the oil seals ① and O-rings ②.

CAUTION

The removed oil seals and O-rings should be replaced with new ones.

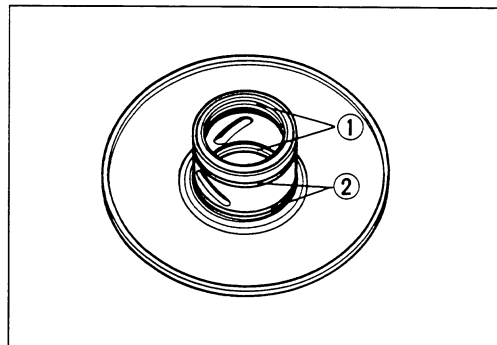
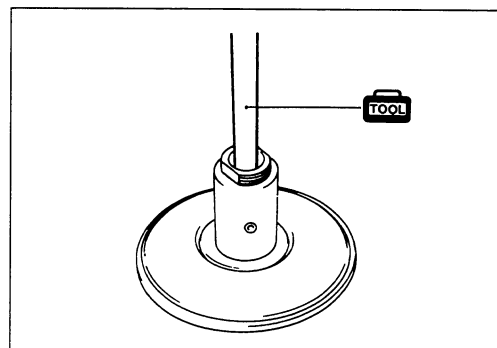

CLUTCH SHOE

Clutch shoe—inspect the shoes visually for chips, cracking, uneven wear and burning, and check the thickness of the shoes with vernier calipers. If the thickness is less than the following service limit, replace them as a set.

Service Limit: 2.0 mm (0.08 in)

Clutch springs—visually inspect the clutch springs for stretched coils or broken coils.

CAUTION

Clutch shoes or springs must be replaced as a set and never individually.

Clutch wheel—inspection visually the condition of the inner clutch wheel surface for scuffing, cracks, or uneven wear. Measure inside diameter of the clutch wheel with inside calipers. Measure the diameter at several points to check for an out-of-round condition as well as wear.

Service Limit: 110.50 mm (4.350 in)

DRIVEN FACE SPRING

Measure the free length of the driven face spring. If the length is shorter than the service limit, replace the spring with a new one.

Service Limit: 104.5 mm (4.11 in)

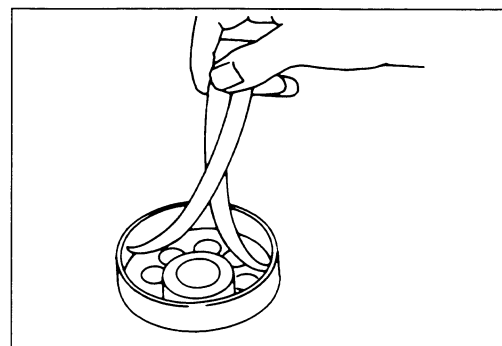
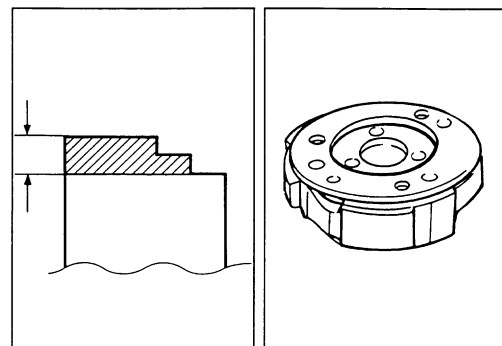

Measuring clutch wheel I.D.

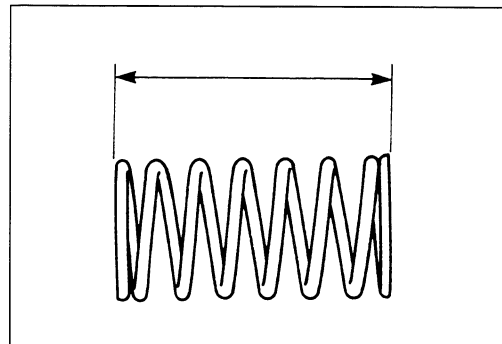

DRIVEN FACE PIN AND OIL SEAL

Turn the driven faces and check to see that the driven faces turn smoothly.

If any stickiness or hitches are found, visually inspect the lip of oil seal, driven face sliding surface and sliding pins for wear or damage.

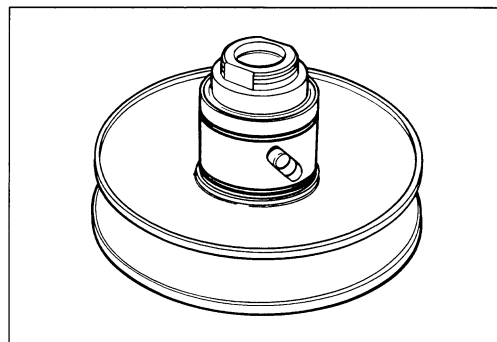

DRIVEN FACE

Inspect the belt contacting surface of both driven faces for any scratches, wear and damage.

Replace driven face with new one if there are any abnormality.

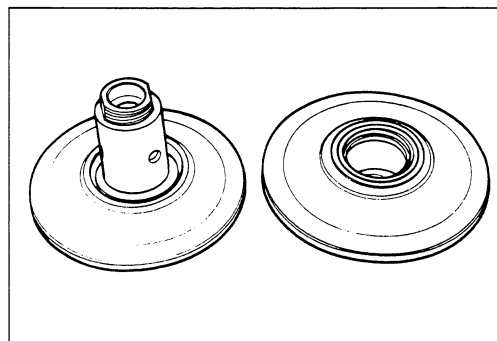

REASSEMBLY

Reassemble the clutch and movable driven in the reverse order of disassembly, and also carry out the following steps.

- Install the bearing ② in the fixed driven face ① with the special tool.

 **09943-88211: Bearing installer**

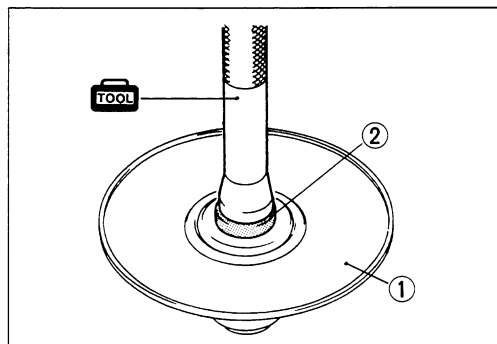

- Install the circlip securely.

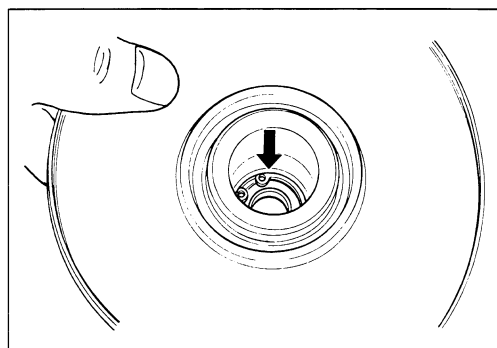

- Install the needle roller bearing with the special tool.

 **09924-84521: Bearing installer**

NOTE:

Face the stamped side of the bearing to the outside.

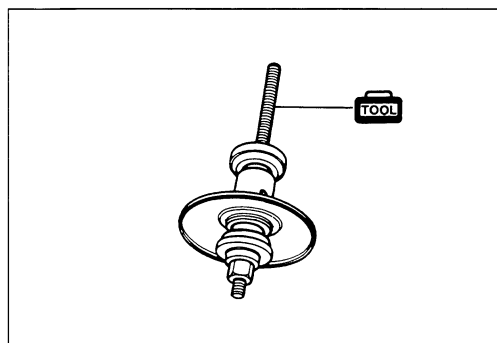

- Apply grease to the sliding surface between fixed driven face and movable driven face.

 **99000-25010: SUZUKI SUPER GREASE "A"**

NOTE:

When reinstalling the movable face to the fixed face, make sure that the oil seal is positioned properly.

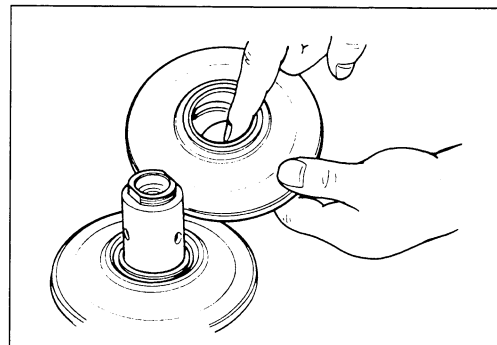

- Install the pin ① at three places on the driven face hub.
- Apply grease lightly to the cam part where the pins are placed.
- Position two O-rings ②.

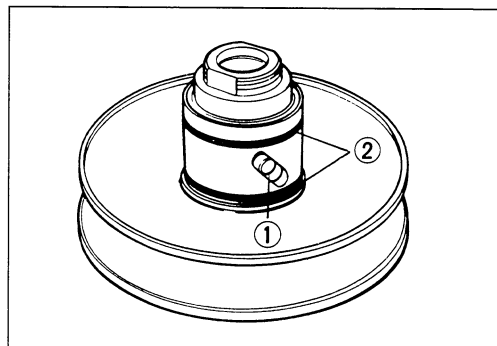

- Tighten the nut to the specified torque with the special tool.

 **09930-40113: Rotor holder**

 **Clutch shoe nut: 50 N·m (5.0 kg-m, 36.0 lb-ft)**

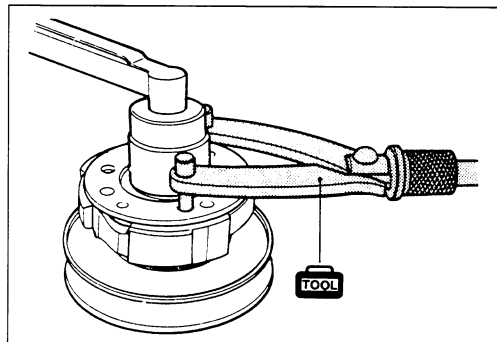

MOVABLE DRIVE

DRIVE FACE

Inspect the belt contact surface of the drive faces for wear, scratches or any abnormality. If there is something unusual, replace the drive face with a new one.

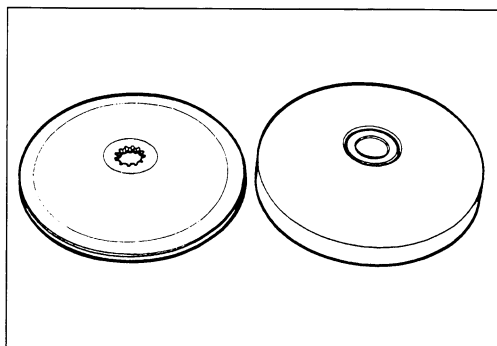

ROLLER AND SLIDING SURFACE

Inspect each roller and sliding surface for wear or damage.

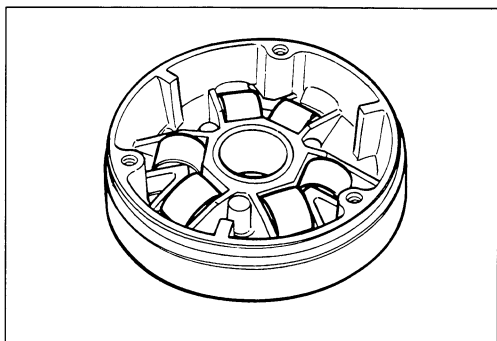

DRIVE BELT

Remove the drive belt and check for cracks, wear and separation. Measure the drive belt width with a vernier calipers. Replace it if the belt width is less than the service limit or any defect has been found.

Service Limit: 16.0 mm (0.63 in)

⚠ CAUTION

Always keep the drive belt away from any greasy matter.

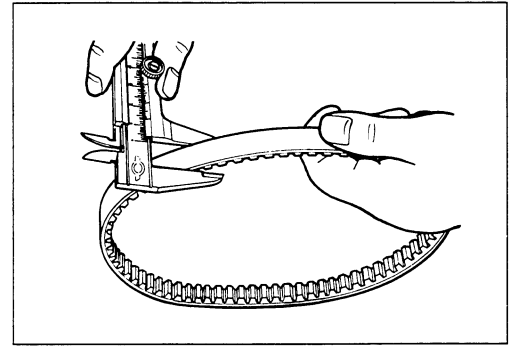

CYLINDER HEAD

Decarbon the combustion chamber. Check the gasketed surface of the cylinder head for distortion with a straightedge and thickness gauge, taking a clearance reading at several places.

TOOL 09900-20803: Thickness gauge

Service Limit: 0.05 mm (0.002 in)

If the largest reading at any portion of the straightedge exceeds the limit, rework the surface by rubbing it against emery paper (of about #400) laid flat on the surface plate in a lapping manner. The gasketed surface must be smooth and perfectly flat in order to secure a tight joint: a leaky joint can be the cause of reduced power output and increased fuel consumption.

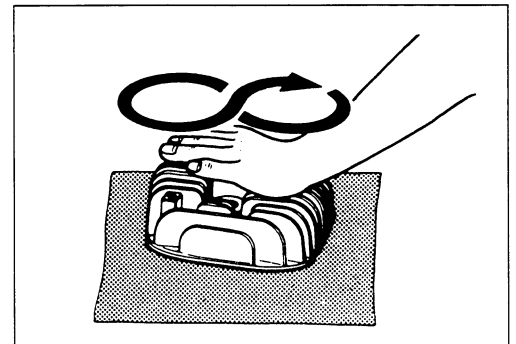
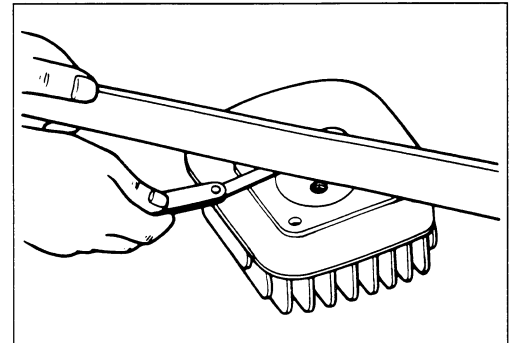

CYLINDER

Decarbon exhaust port and upper part of the cylinder, taking care not to damage the cylinder wall surface.

The wear of the cylinder wall is determined from diameter reading taken at 20 mm from the top of the cylinder with a cylinder gauge. If the wear thus determined exceeds the limit indicated below, rework the bore to the next oversize by using a boring machine or replace the cylinder with a new one. Oversize pistons are available in two sizes: 0.5 mm and 1.0 mm oversizes.

TOOL 09900-20508: Cylinder gauge set

Service Limit: 41.075 mm (1.6171 in)

After reworking the bore to an oversize, be sure to chamfer the edges of ports and smooth the chamfered edges with emery paper. To chamfer, use a scraper, taking care not to nick the wall surface.

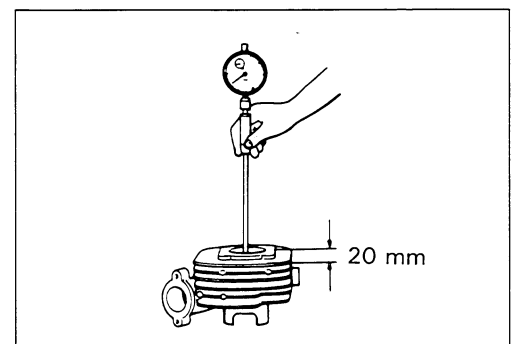
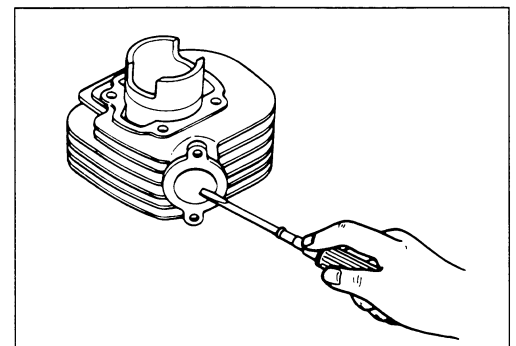

NOTE:

Minor surface flaws on the cylinder wall due to seizure or similar abnormalities can be corrected by grinding the flaws off with fine-grain emery paper. If the flaws are deep grooves of otherwise persist, the cylinder must be reworked with a boring machine to the next oversize.

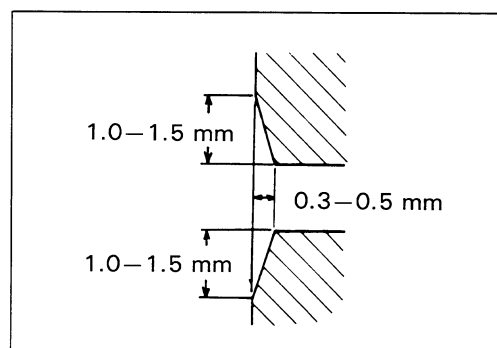
**PISTON****CYLINDER TO PISTON CLEARANCE**

Cylinder-to-piston clearance is the difference between piston diameter and cylinder bore diameter. Be sure to take the measured diameter at right angles to the piston pin. The value of elevation $\text{\textcircled{A}}$ is prescribed to be 15 mm from the skirt end.

TOOL 09900-20202: Micrometer (25–50 mm)

Service Limit: 40.885 mm (1.6096 in)

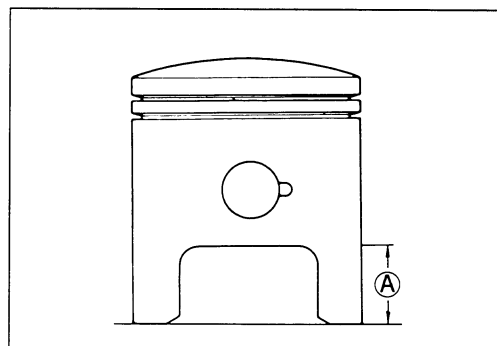

As a result of the above measurement, if the piston-to-cylinder clearance exceeds the following limit, overhaul the cylinder and use an oversize piston, or replace both cylinder and piston. The measurement for the bore diameter should be taken in the intake-to-exhaust port direction and at 20 mm from the cylinder top surface.

Unit: mm

	STD	Service Limit
Cylinder	41.005–41.020	41.075
Piston	40.940–40.955	40.885
Cylinder to piston	0.06–0.07	0.120

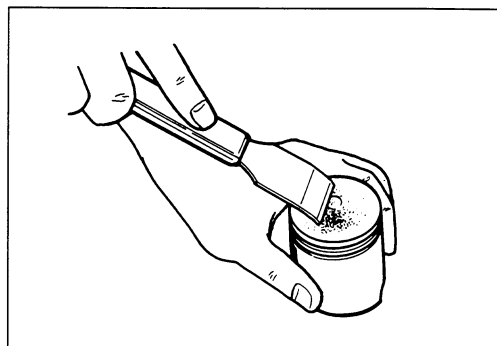
**DE-CARBONING**

De-carbon the piston and piston ring grooves, as illustrated. After cleaning the grooves, fit the rings and rotate them in their respective grooves to be sure that they move smoothly.

Carbon in groove is liable to cause the piston ring to get stuck in the groove, and this condition will lead to reduced engine power output.

A piston whose sliding surface is badly grooved or scuffed due to overheating must be replaced. Shallow grooves or minor scuff can be removed by grinding with emery paper of about #400.

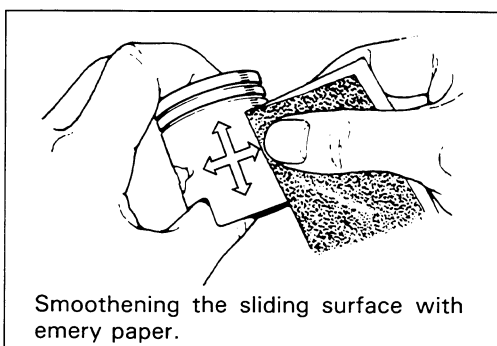
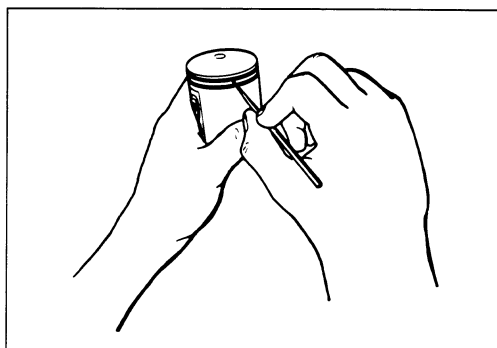

PISTON PIN BORE

Using a caliper gauge, measure the piston pin bore inside diameter. If reading exceeds the following service limit, replace it with a new one.

TOOL 09900-20605: Dial calipers

Service Limit: 10.030 mm (0.3949 in)

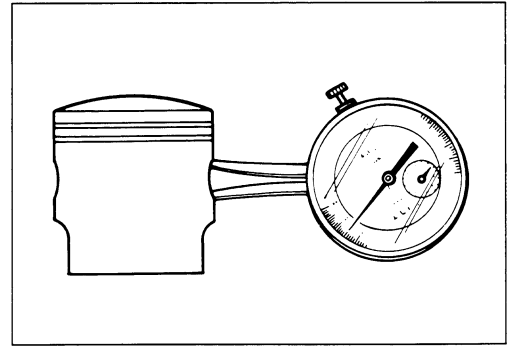

PISTON PIN O.D.

Using a micrometer, measure the piston outside diameter at three positions.

TOOL 09900-20205: Micrometer (0–25 mm)

Service Limit: 9.980 mm (0.3929 in)

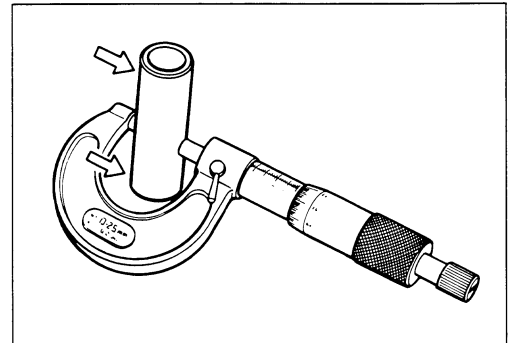

PISTON RINGS

Check each ring for end gap, reading the gap with a thickness gauge shown in the illustration. If the end gap is found to exceed the limit, indicated below, replace it with a new one.

The end gap of each ring is to be measured with the ring fitted squarely into the cylinder bore and held at the least worn part near the cylinder bottom, as shown in the illustration.

TOOL 09900-20803: Thickness gauge

Service Limit: 0.80 mm (0.031 in)

As the piston ring wears, its end gap increase reducing engine power output because of the resultant blow by through the enlarged gap. Here lies the importance of using piston rings with end gaps within the limit.

Measure the piston ring free end gap to check the spring tension.

Service Limit: 3.2 mm (0.126 in) ... 1st
3.4 mm (0.134 in) ... 2nd

Fix the piston ring in the piston ring groove, measure the ring side clearance with the thickness gauge while matching the sliding surfaces of piston and ring.

STD Clearance: 0.020–0.060 mm (0.0008–0.0024 in)
(1st and 2nd)

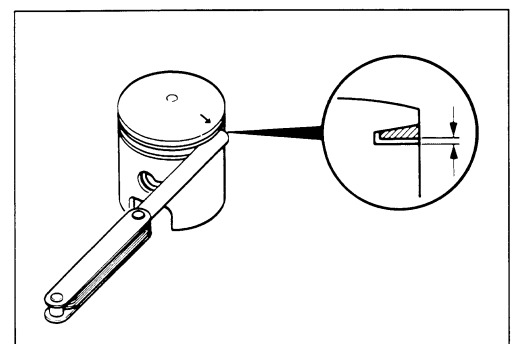
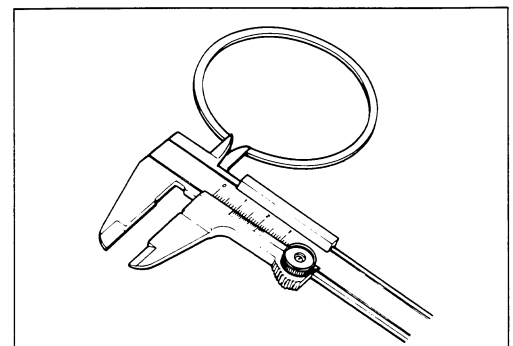
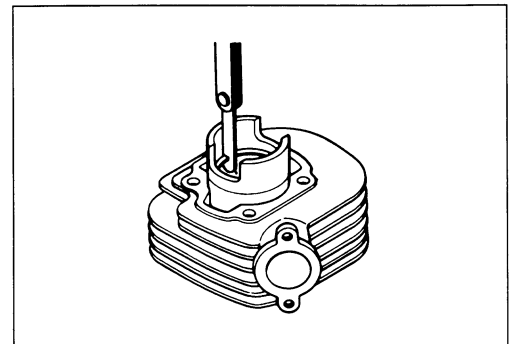

REED VALVE

Check the clearance **(A)** between reed valve and its seat and the dimension **(B)**. If the clearance **(A)** is noted to exceed 0.2 mm, replace the reed valve assembly. The dimension **(B)** is at least 1 mm.

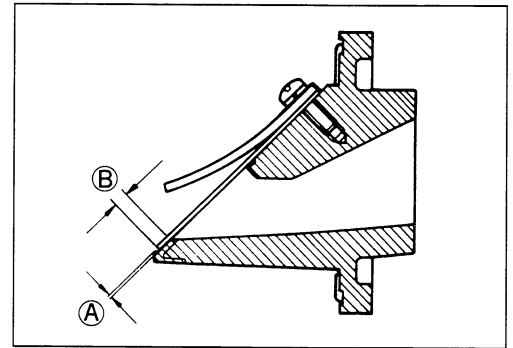

Apply THREAD LOCK "1342" to the reed valve mounting screws.

 99000-32050: THREAD LOCK "1342"

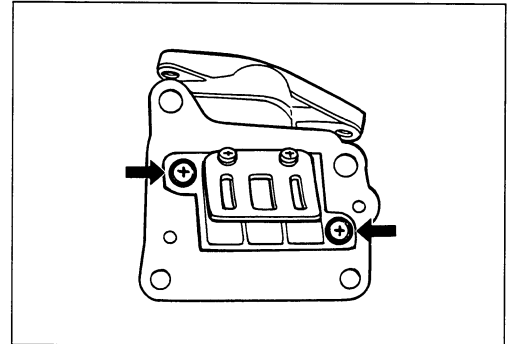

ENGINE REASSEMBLY

Reassembly is generally performed in the reverse order of disassembly, but there are a number of reassembling steps that demand or deserve detailed explanation or emphasis. These steps will be taken up for respective parts and components.

OIL SEALS

Fit the oil seals to the crankcase following the procedure below.

NOTE:

Replace removed oil seals with new ones.

- Apply grease to the lip of the oil seals.

99000-25010: SUZUKI SUPER GREASE "A"

- Be sure to apply THREAD LOCK "1342" to outer surfaces of right and left crankshaft oil seals to prevent them from moving.

99000-32050: THREAD LOCK "1342"

- When fitting the oil seal in the crankcase, insert it slowly with the special tools.

-  09913-76010: Oil seal installer
- 09924-74510: Oil seal installer handle
- 09924-74540: Oil seal installer attachment

NOTE:

Align the oil seal with edge  of the crankcase as shown in the illustration.

BEARINGS

Install new bearings with the special tools.

-  09913-75810: Bearing installer
- 09913-76010: Bearing installer

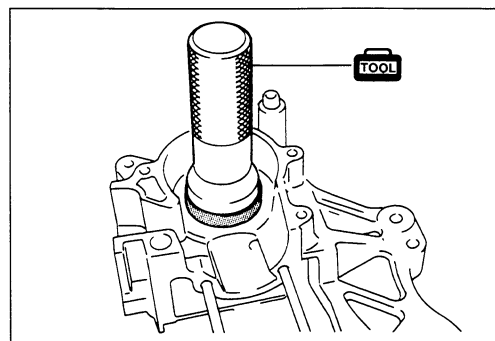
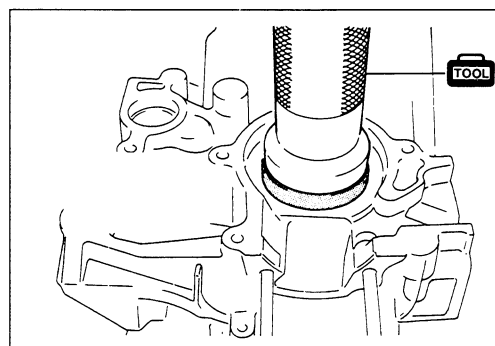
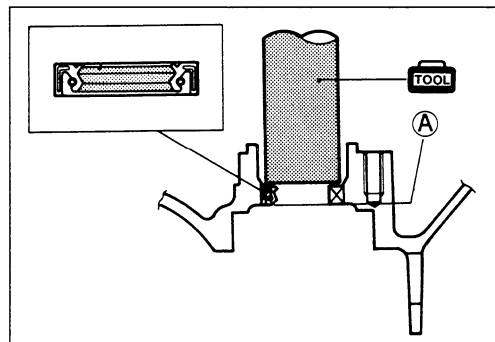
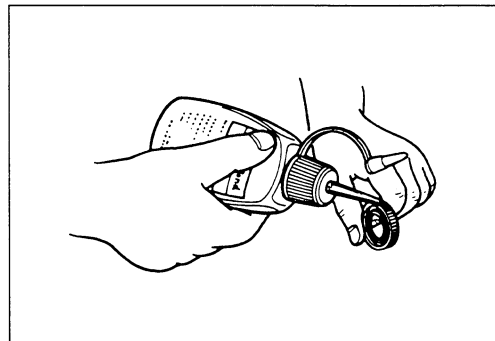

BUSHINGS

Using two steel tubes of appropriate size and a vise, press the mounting bushings ① and ② into the crankcase holes as shown in the illustration.

NOTE:

Knurled end ③ should face inside. Protrusion ④ and ⑤ should be in the same dimension.

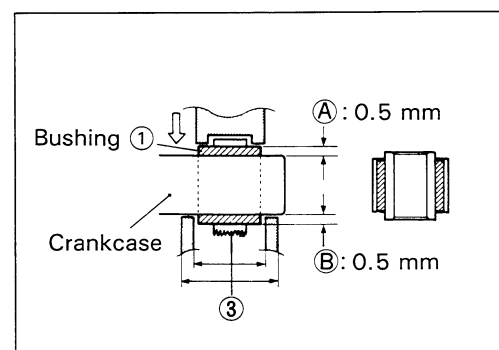
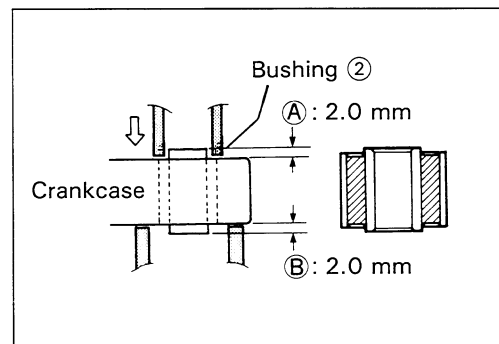
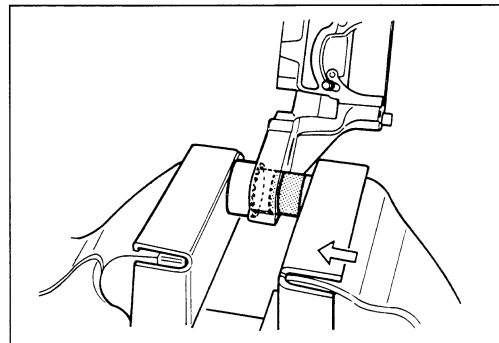
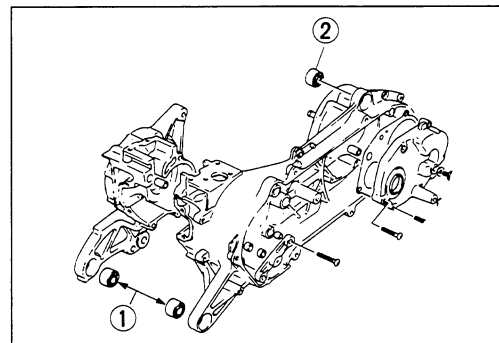

CRANKSHAFT

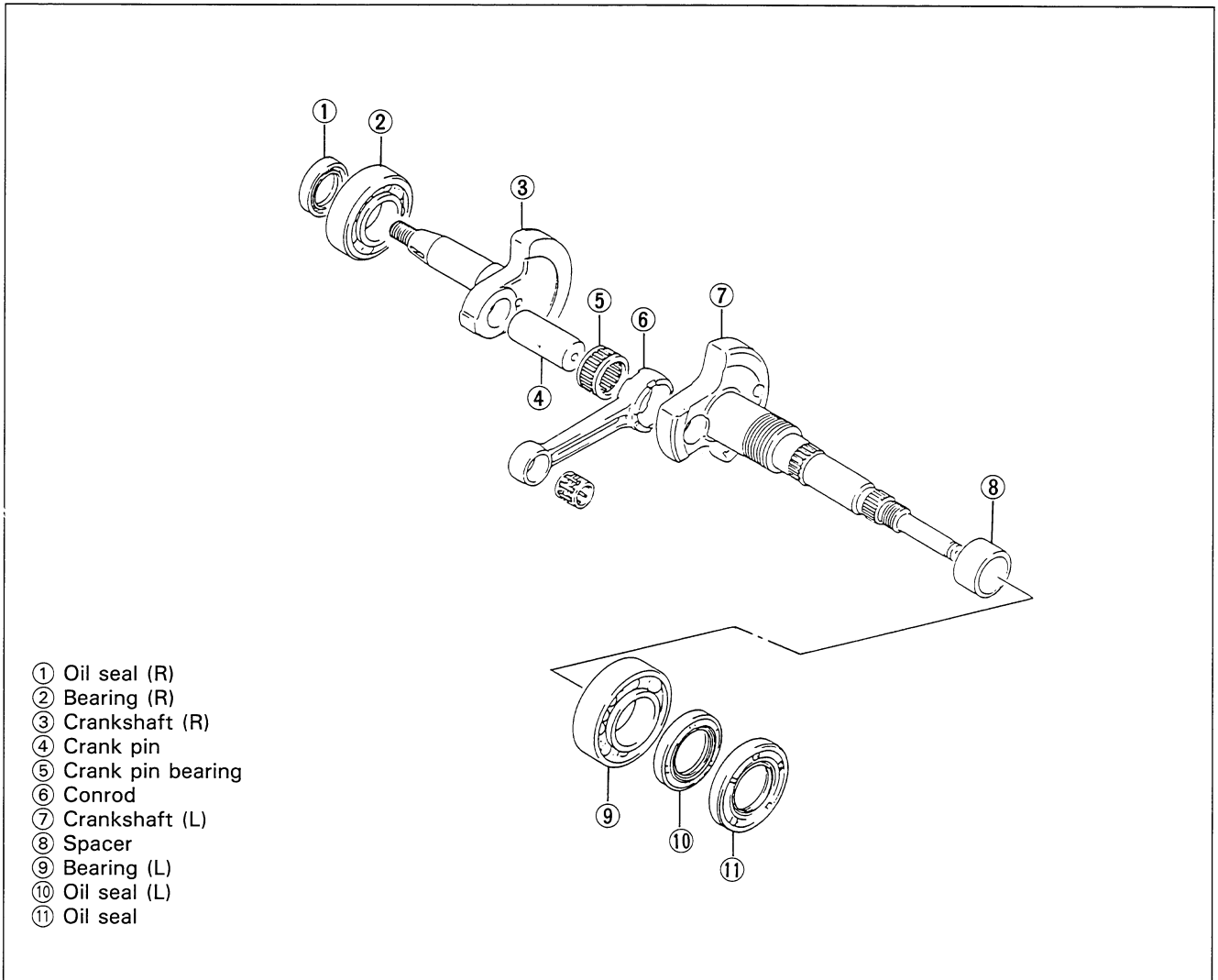

- Decide the length between the webs referring to the figure at right when rebuilding the crankshaft.

Standard width between webs: 35.0 ± 0.1 mm
(1.378 ± 0.004 in)

- When mounting the crankshaft into the right crankcase, it is necessary to pull its right end into the crankcase with the special tools.

TOOL 09910-32812: Crankshaft installer
 09910-20116: Conrod holder

CAUTION

Never fit the crankshaft into the crankcase by driving it with a plastic hammer. Always use the special tool, otherwise crankshaft alignment accuracy will be affected.

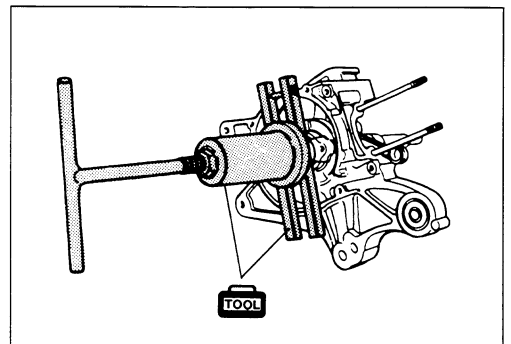
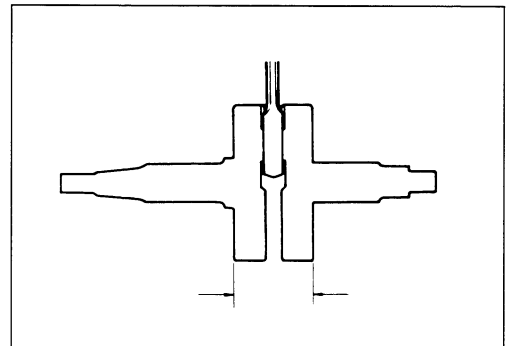

CRANKCASE

- Apply SUZUKI BOND "1215" uniformly to the fitting surface of the right half of the crankcase.

1215 99000-31110: SUZUKI BOND "1215"

- Install the two dowel pins.
- Fit the left half on the right half after waiting a few minutes.

- Tighten the crankcase bolts.
- Install the new oil seal ① with the special tool as shown in the illustration.

TOOL 09941-74910: Oil seal installer

- Apply SUZUKI SUPER GREASE "A" to the oil pump drive gear on the crankshaft surface approximately 10 g of grease.

A 99000-25010: SUZUKI SUPER GREASE "A"

- Install the new oil seal with the special tool.

TOOL 09951-16080: Oil seal installer

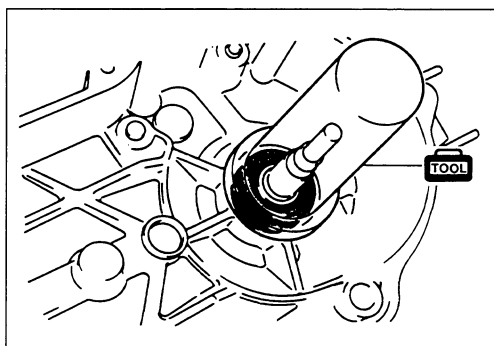
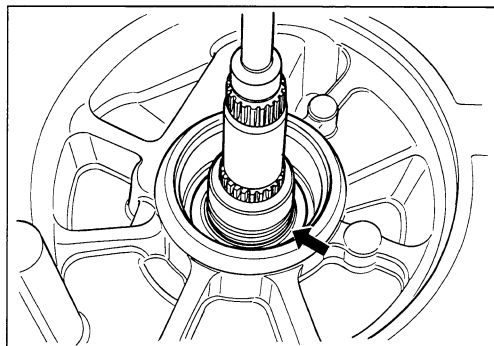
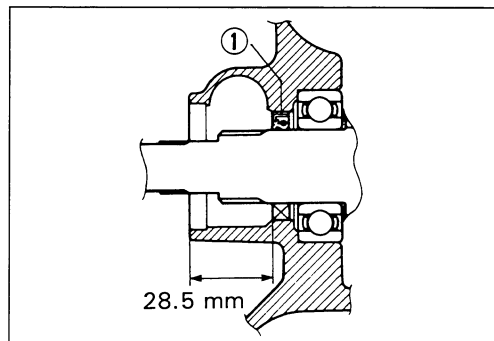
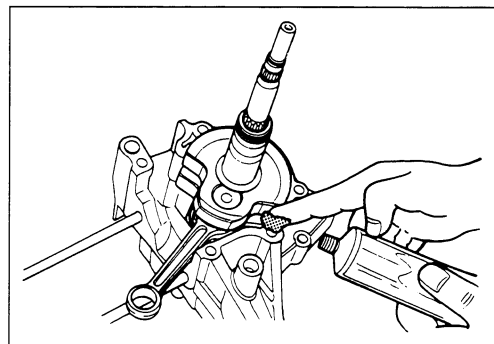

REAR AXLE SHAFT

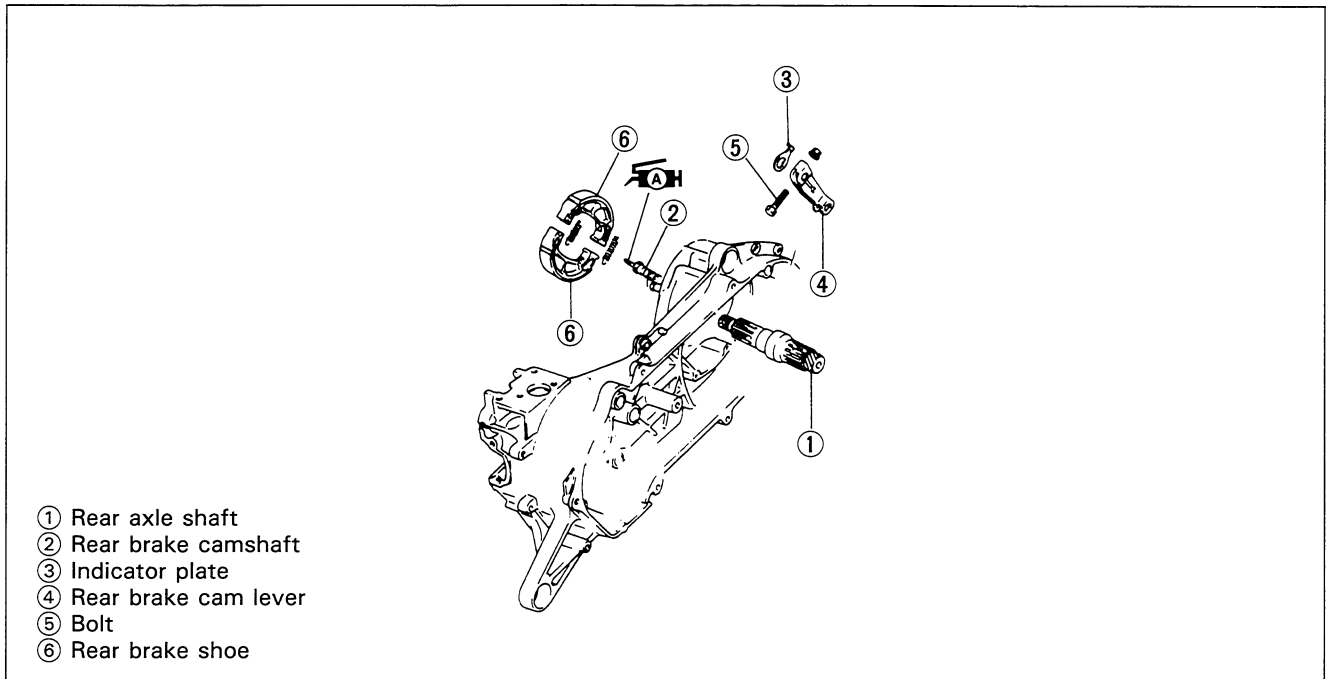

- Install the rear axle shaft ① into the crankcase by tapping its end lightly.
- Apply engine oil on the left end of the rear axle shaft before inserted later in the reduction rear box cover.

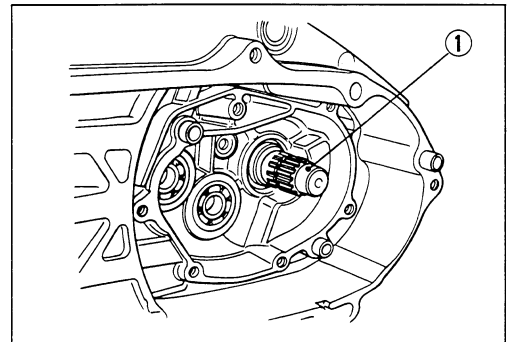

- Apply grease lightly on the rear brake cam pivot part and install it to the crankcase.

 99000-25010: SUZUKI SUPER GREASE "A"

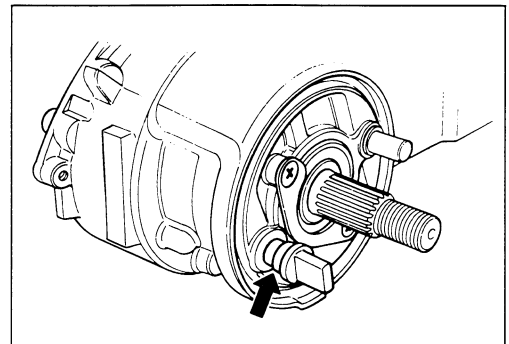

- Turn to position the cam where the punched mark (A) on the end face is directed toward the axis of the rear axle shaft.

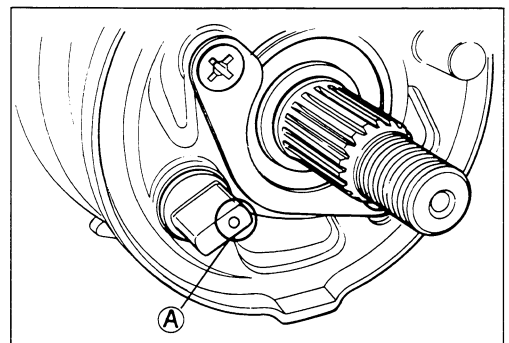

- Aligning the tang on the wear indicator plate with a cutaway on the rear brake cam serrated end, slide the indicator plate over the cam serration.

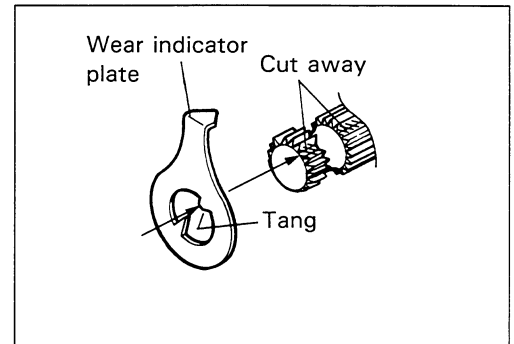
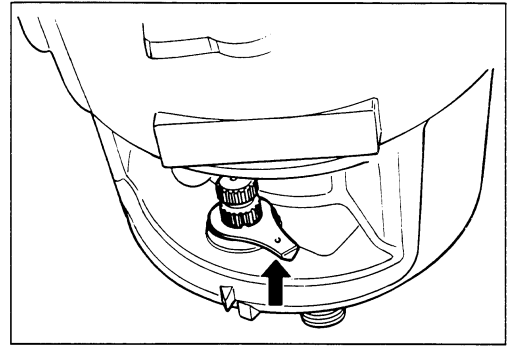

- Install the rear brake cam lever on the cam and tighten the lever nut to the specified torque.

 **Rear brake cam lever nut: 7 N·m (0.7 kg-m, 5.0 lb-ft)**

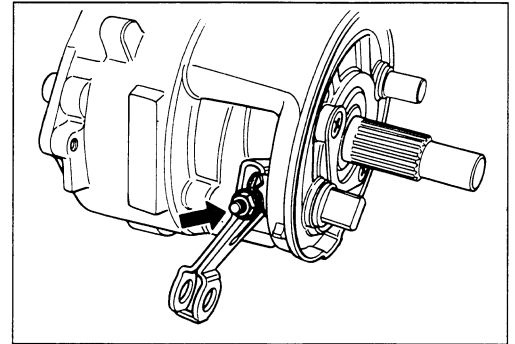

- Install the brake shoes.
- Install the rear wheel.

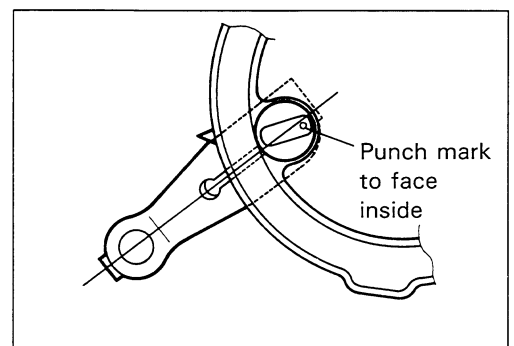

TRANSMISSION

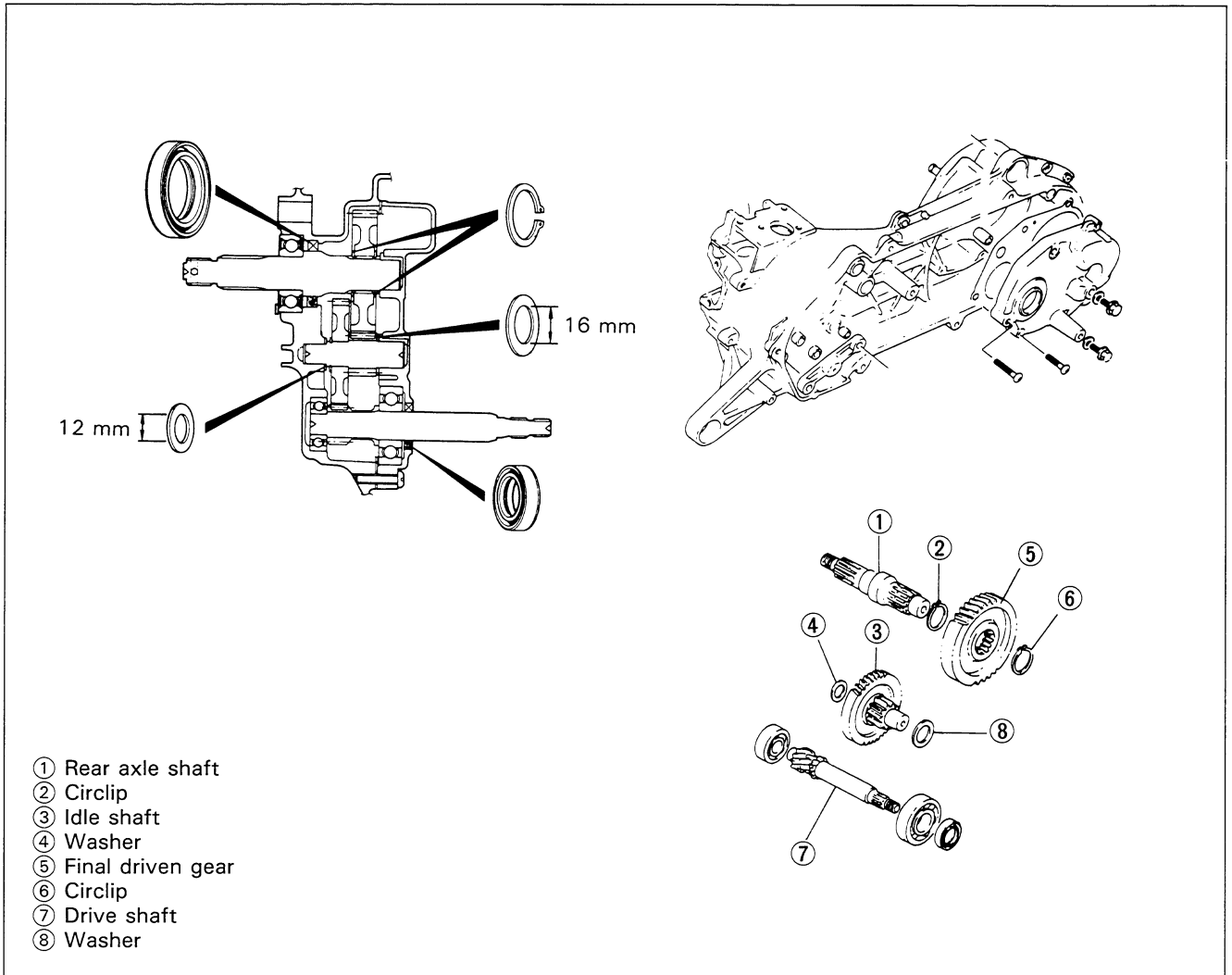

- Install the idle shaft ① with thrust washer ② to the gear box.

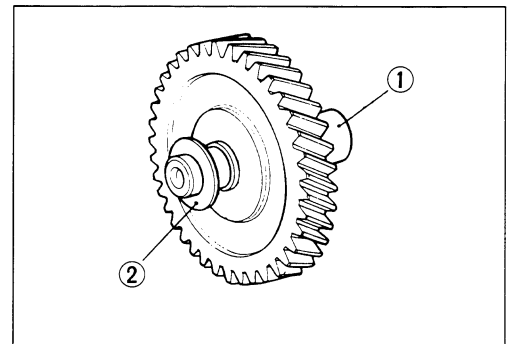

- Install the final driven gear ③ on the rear axle shaft using the circlip ④.

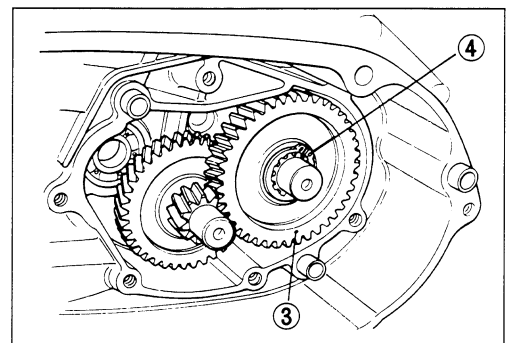

NOTE:

When using a circlip, always discriminate between its two faces; one with sharp corners and the other with rounded corners. When installing, determine the direction of thrust being applied and position the circlip so that it supports the thrust with its sharp corner securely catching the shaft groove as shown in the illustration.

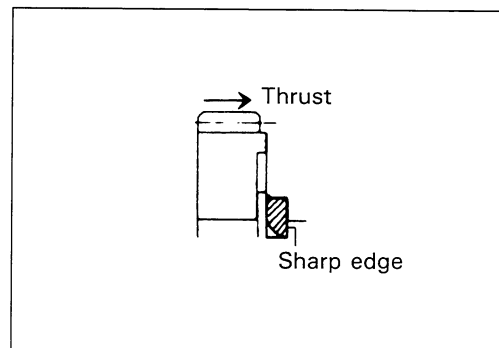

- Install the driveshaft to the gear box cover.

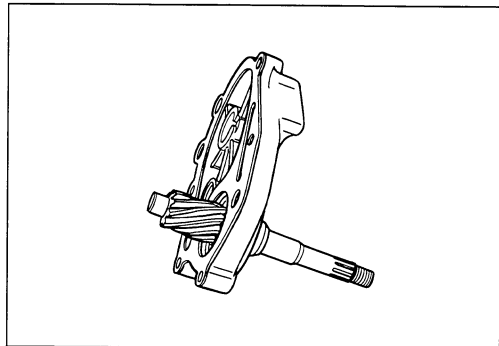

- Position the idle shaft washer ① on the idle shaft.
- Position the gasket ② properly in place.
- Install the two dowel pins ③ through the gasket.

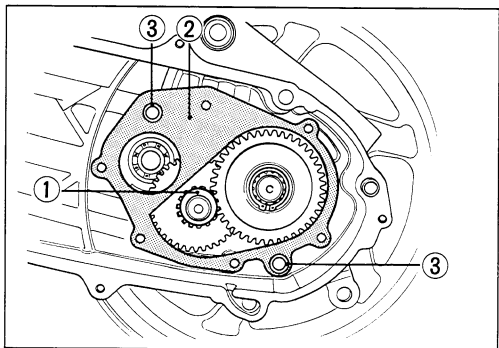

- Apply SUZUKI BOND NO. 1215 at the hatched area A of the gear box cover as shown in the illustration and install the gear box cover on the crankcase.

1215 99000-31110: SUZUKI BOND NO. 1215

- Tighten all the screws evenly one by one in a diagonal manner.
- Tighten the oil drain bolt ④.

 Oil drain bolt: 6 N·m (0.6 kg-m, 4.5 lb-ft)

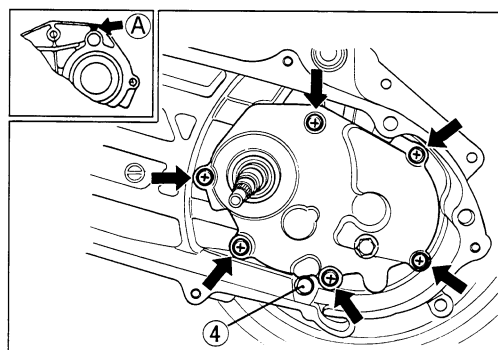

STARTER PINION AND STARTER GEAR

- Apply grease on the pinion shaft and install the starter pinion subassembly.
- Assemble the starter pinion subassembly ①.

 **099000-25010: SUZUKI SUPER GREASE "A"**

- Insert the two dowel pins ②.
- Install the starter idle gear cap ③.

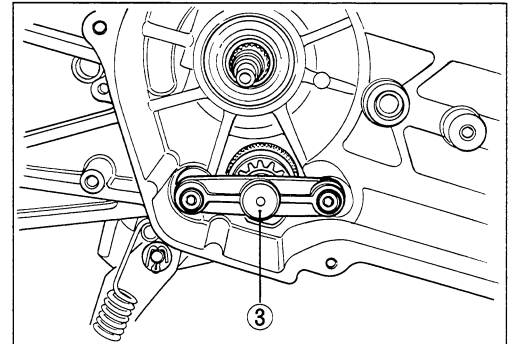
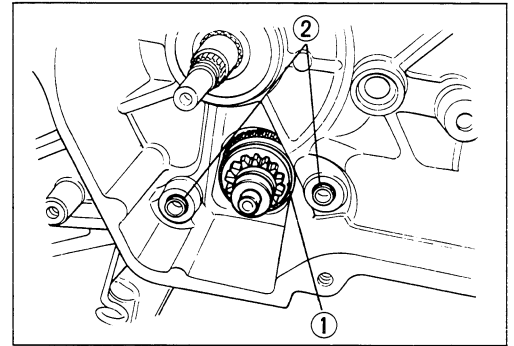

- Install the starter gear ④ over the left crankshaft end.

NOTE:

The convex side of hub should face outside when installed in proper position.

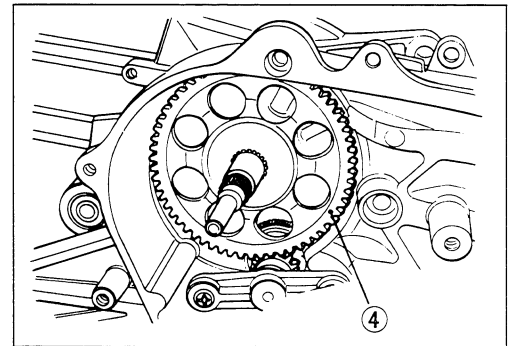

DRIVE BELT

- Insert the drive belt between the driven faces as deep inside as possible while pulling the movable driven face all the way outside to provide the maximum belt clearance.

CAUTION

The belt contact face on the driven faces should be thoroughly cleaned to be free from oil.

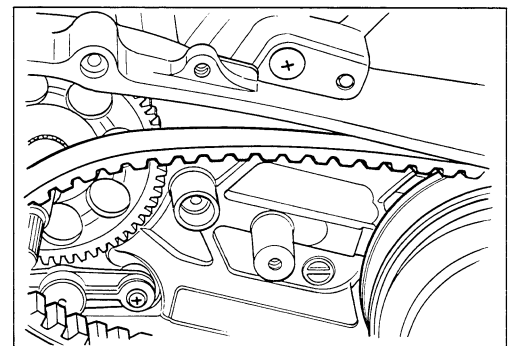

- Thoroughly clean the clutch housing to be free from oil and position it over the clutch shoe assembly.
- Tighten the clutch housing nut to the specified torque with the special tool.

 **09930-40113: Rotor holder**

 **Clutch housing nut: 50 N·m (5.0 kg·m, 36.0 lb-ft)**

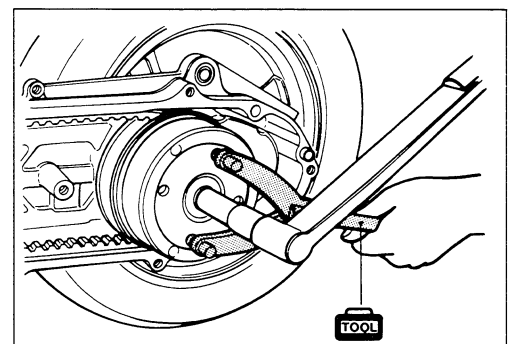

MOVABLE DRIVE

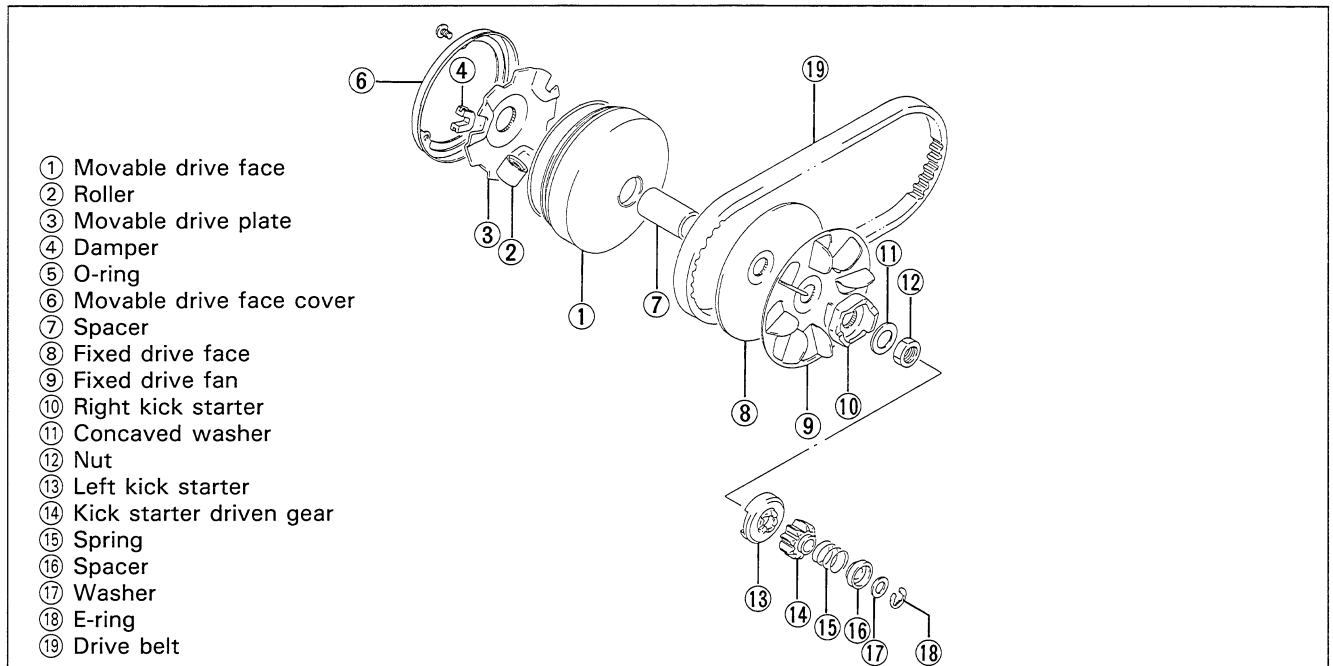

- Mount the three dampers ① on the movable drive plate ② and install it on the movable drive face.

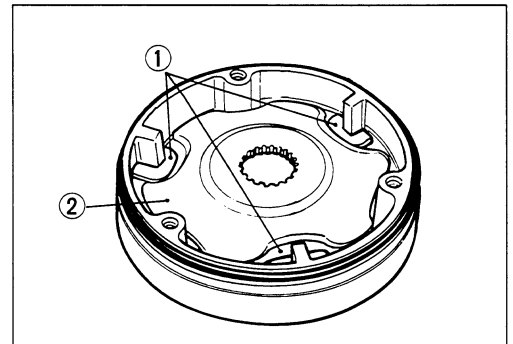

- Install the movable drive face cover ③.

NOTE:

Make sure that the movable drive plate is fully positioned inside, or the weight roller may come off.

- Insert the spacer ④.

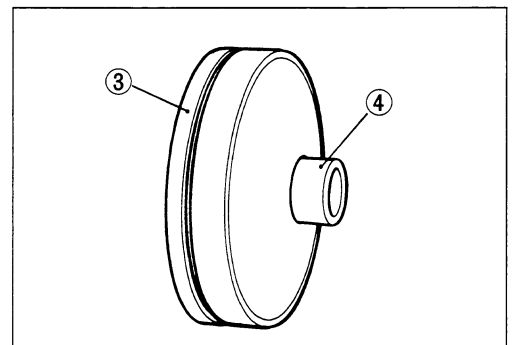

- Position the movable drive face subassembly on the crankshaft as shown in the illustration.

NOTE:

Thoroughly clean the belt contact part to be free from oil.

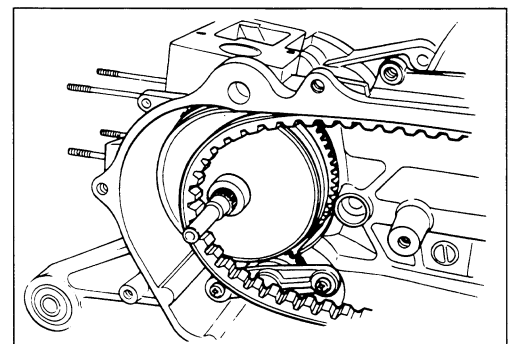

3-35 ENGINE

- Install the fixed drive fan.
- Tighten the nut to the specified torque with the special tool.

 **09910-20115: Conrod holder**

 **Kick starter nut: 50 N·m (5.0 kg-m, 36.0 lb-ft)**

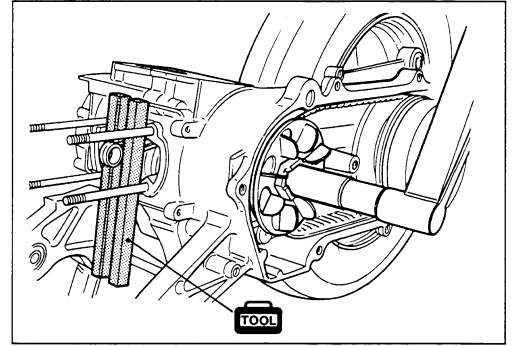

- Fill grease in the groove provided inside sliding surface of the kick driven gear, and install it on the end of the crankshaft. Wipe off excess grease.

 **99000-25010: SUZUKI SUPER GREASE "A"**

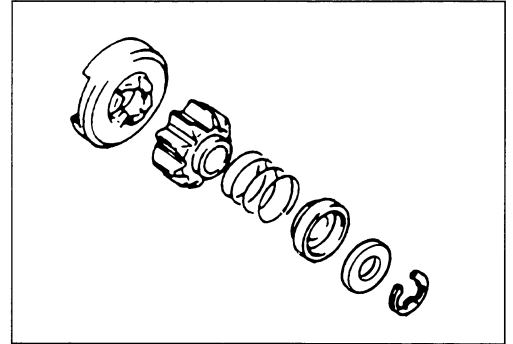

- Continue turning the fixed drive face ① by hand until the belt is seated in and both the drive and driven faces will move together smoothly without slip.

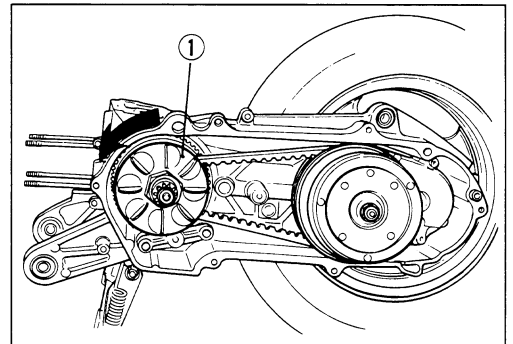

- Fill the final gear box with engine oil up to the level hole.

Oil Capacity: 90 ml (3.2/3.4 US/Imp oz)

- Tighten the oil level bolt to the specified torque.

 **Oil level bolt: 12 N·m (1.2 kg-m, 8.5 lb-ft)**

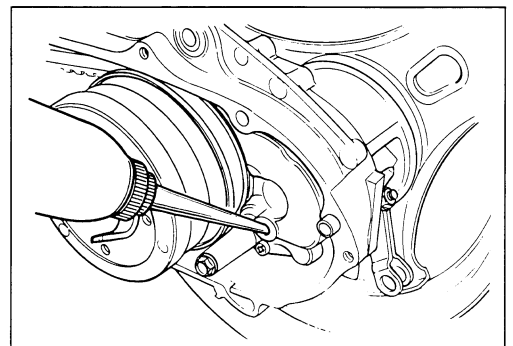

KICK STARTER

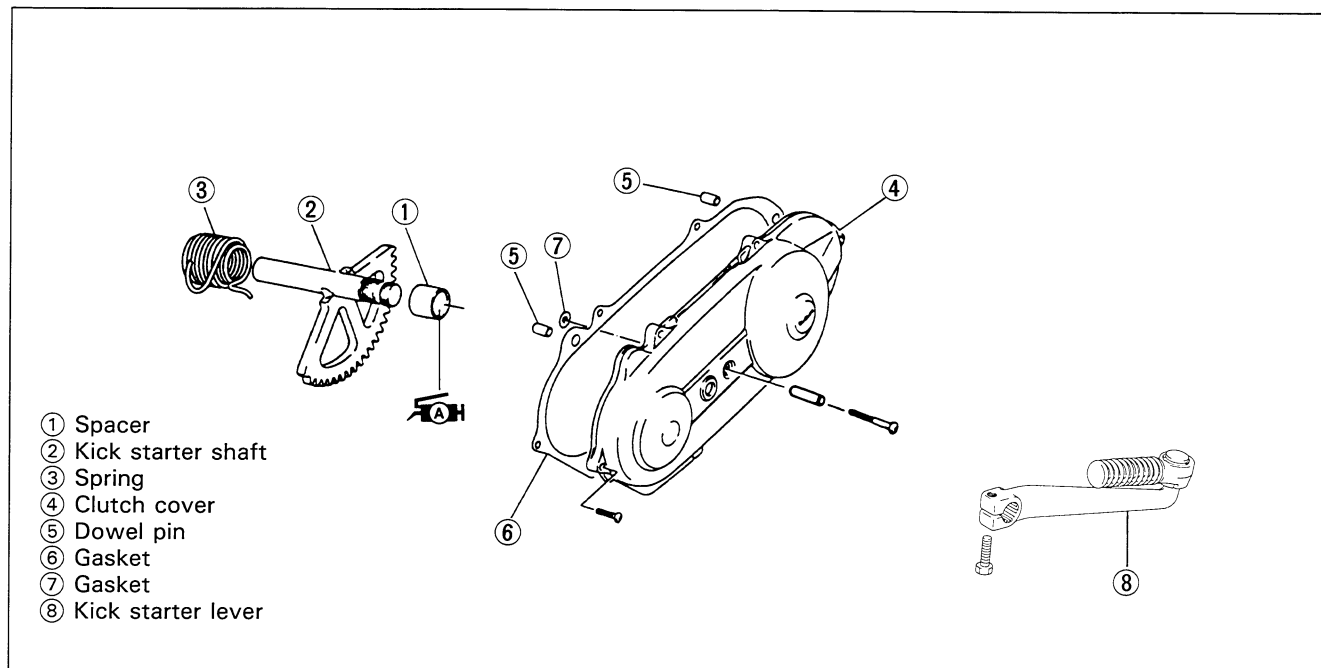

- Apply grease on inside surface of the kick starter shaft spacer.

 99000-25010: SUZUKI SUPER GREASE "A"

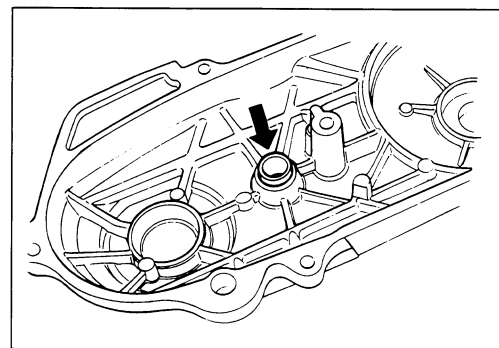

- Apply grease lightly on the end of the kick starter shaft and install it on the clutch cover.
- Position the kick starter shaft return spring and hook the spring end ① on the clutch cover boss ②.

 99000-25010: SUZUKI SUPER GREASE "A"

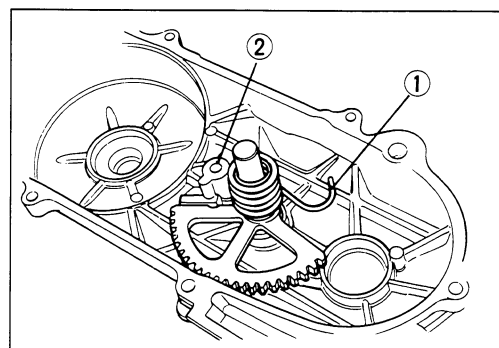

- Install the two dowel pins ③ and new gaskets (④, ⑤).

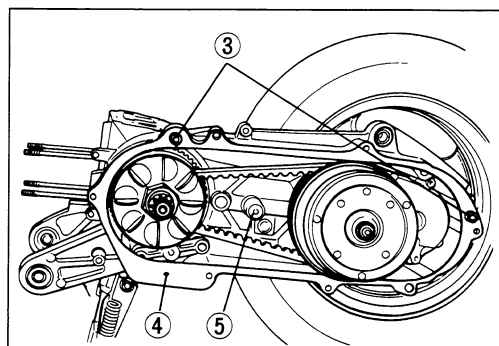

PISTON

- Install the piston rings on the piston.

1st ring : Keystone ring

2nd ring : Rectangular ring and expander ring

NOTE:

Position the ring so that the marking is on upside.

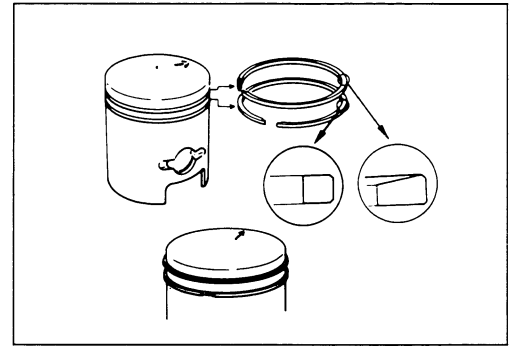

- It is extremely important that, when the piston is fed into the cylinder, each ring in place should be so positioned as to hug the locating pin as shown in the illustration.

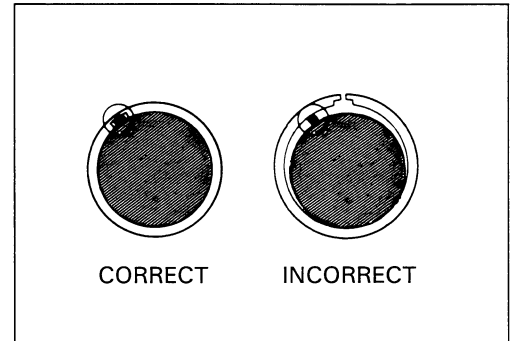

- Fit the circlip ② securely.

NOTE:

The arrow mark ① on the piston head should point the exhaust side.

- Apply CCI SUPER oil on the piston pin and install the piston to the conrod.

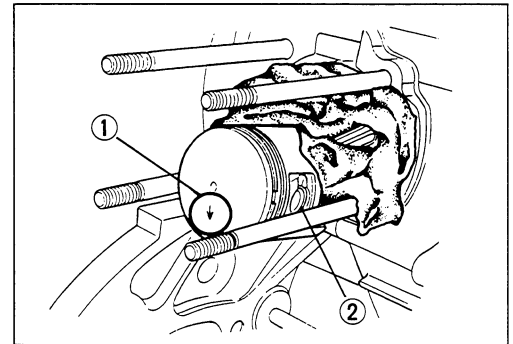

- Position the cylinder base gasket.
- Apply CCI SUPER oil on the piston and cylinder wall surfaces and install the cylinder over the piston carefully.

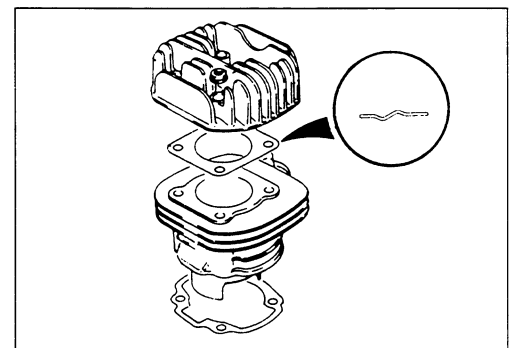

- Tighten the cylinder head nut to the specified torque.

 **Cylinder head nut: 10 N·m (1.0 kg-m, 7.0 lb-ft)**

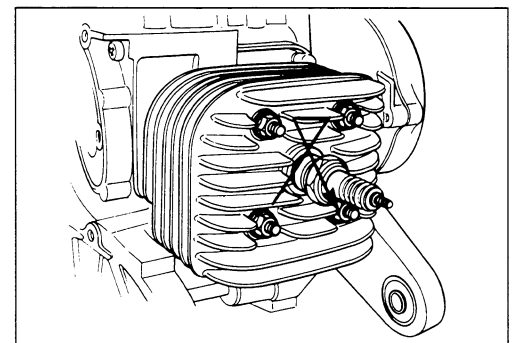

OIL PUMP DRIVEN GEAR

- Apply grease to the oil pump driven gear and install it to the crankcase.

 **99000-25010: SUZUKI SUPER GREASE "A"**

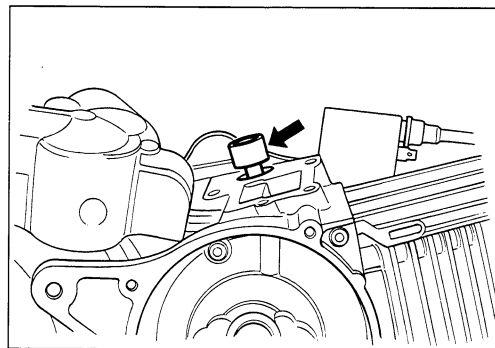

MAGNETO

- Degrease the tapered portion of the crankshaft and also the rotor.
- Install the key ① and stator.

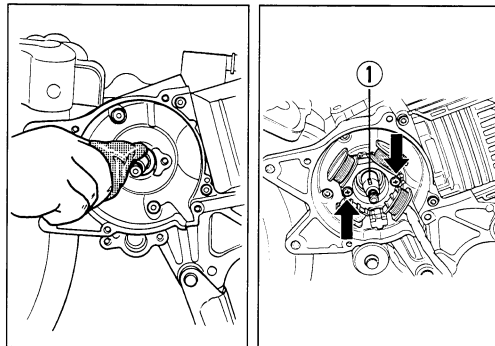

- Apply THREAD LOCK SUPER "1322" to the rotor nut and tighten it to the specified torque with the special tool.

 **99000-32110: THREAD LOCK SUPER "1322"**

 **09930-40113: Rotor holder**

 **Magneto rotor nut: 40 N·m (4.0 kg-m, 29.0 lb-ft)**

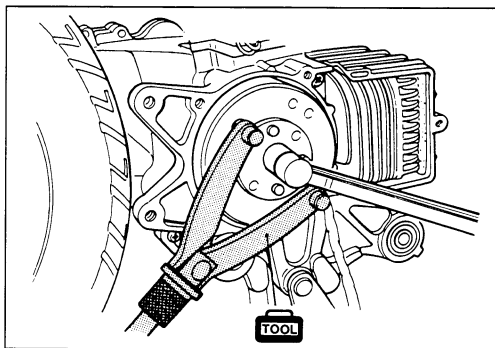

FUEL AND LUBRICATION SYSTEM

CONTENTS

FUEL VALVE	4- 1
FUEL TANK AND OIL TANK	4- 2
CARBURETOR	4- 4
OIL PUMP	4- 9

FUEL VALVE

When the engine has started, a negative pressure (vacuum) is generated at the intake port. The negative pressure acts upon the diaphragm of the fuel valve and it presses down the spring which supports the diaphragm so that the fuel passageway is opened and fuel is fed to the carburetor.

When the engine has stopped, the spring presses the valve, the fuel passageway is closed, and no fuel flows to the engine.

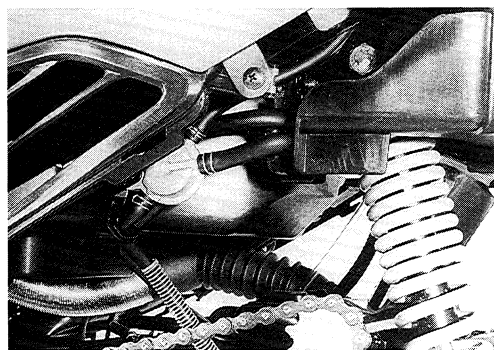
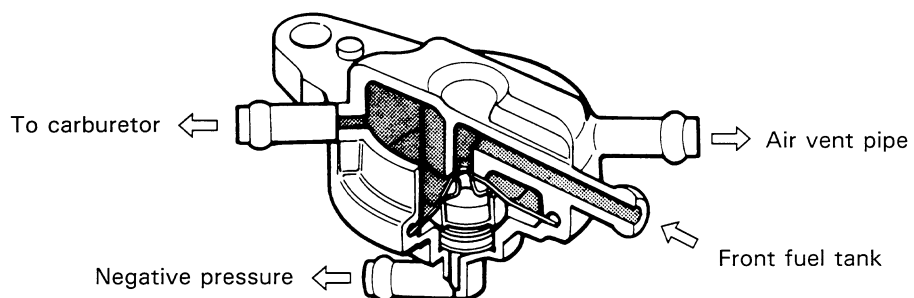

FUEL TANK AND OIL TANK

REMOVAL

⚠ WARNING

Gasoline is very explosive.
Extreme care must be taken.

- Remove the frame covers. (Refer to page 5-2.)
- Remove the fuel and oil tank caps (①, ②).
- Disconnect the drain hose (③).
- Remove the fuel and oil tank cover (④).
- Remove the rear shock absorber (⑤).
- Disconnect the oil level gauge lead wire (⑥).
- Disconnect the fuel hose (⑦) and vacuum hose (⑧) and remove the fuel valve.
- Remove the rear fender mounting bolts (⑧) and screw (⑨).
- Disconnect the oil hose (⑩).
- Remove the fuel tank fixing band (⑪).
- Remove the oil tank (⑫) and rear fender.
- Disconnect the fuel gauge lead wire (⑬) and remove the fuel tank (⑭).

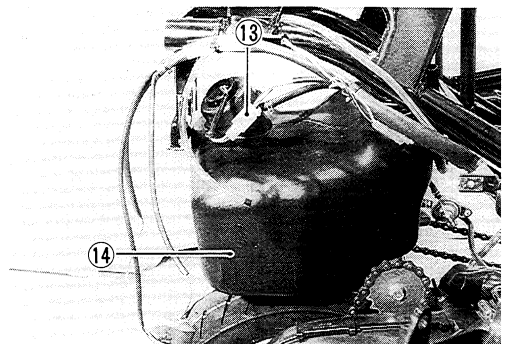
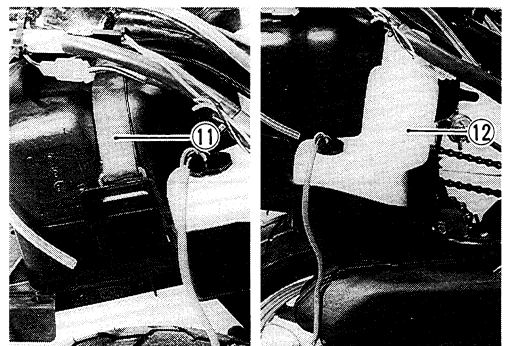
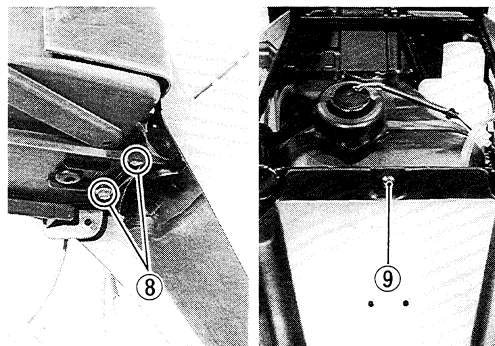
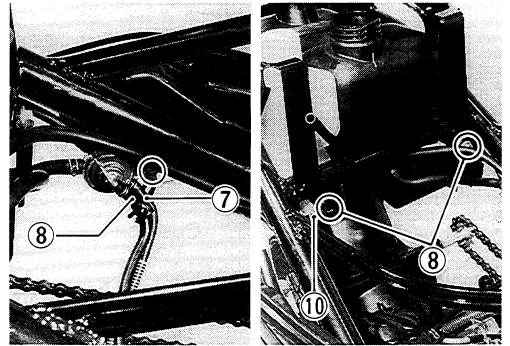
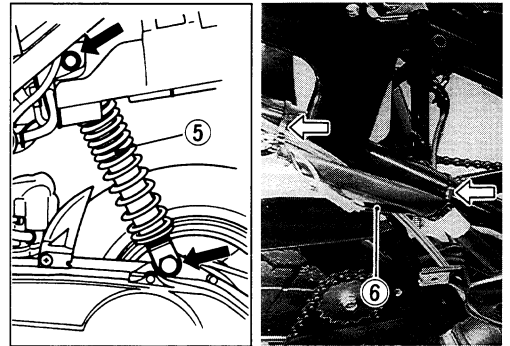
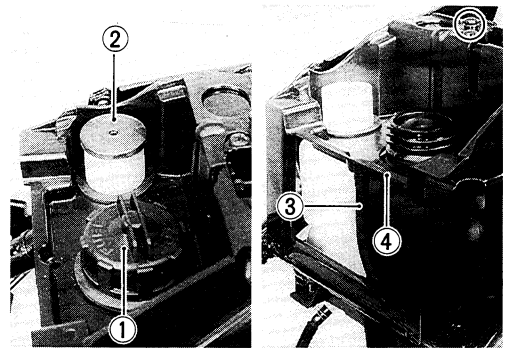

REMOUNTING

- Remount the fuel tank and oil tank in the reverse order of removal.

FUEL TANK AND OIL TANK CUSHIONS

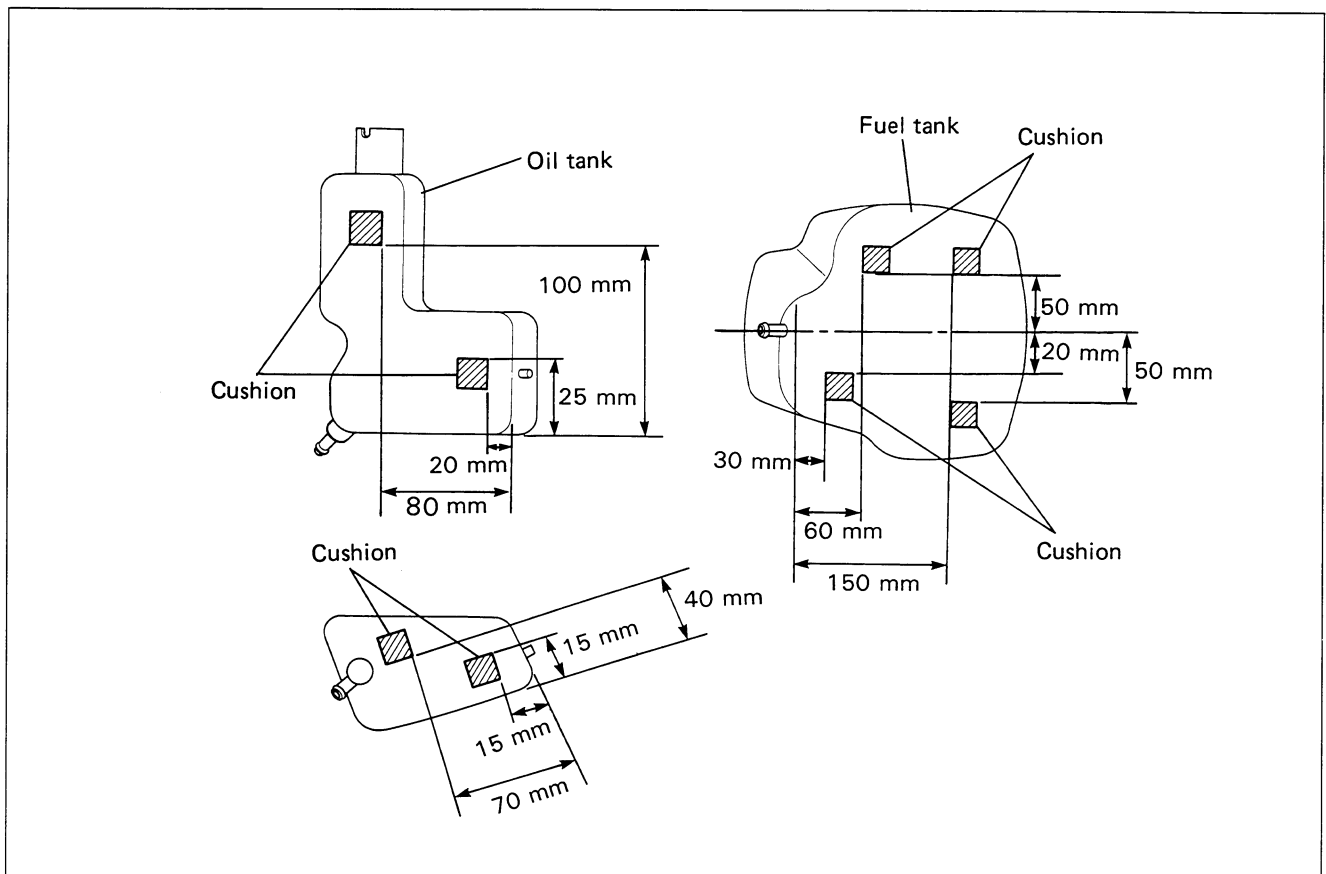

CARBURETOR

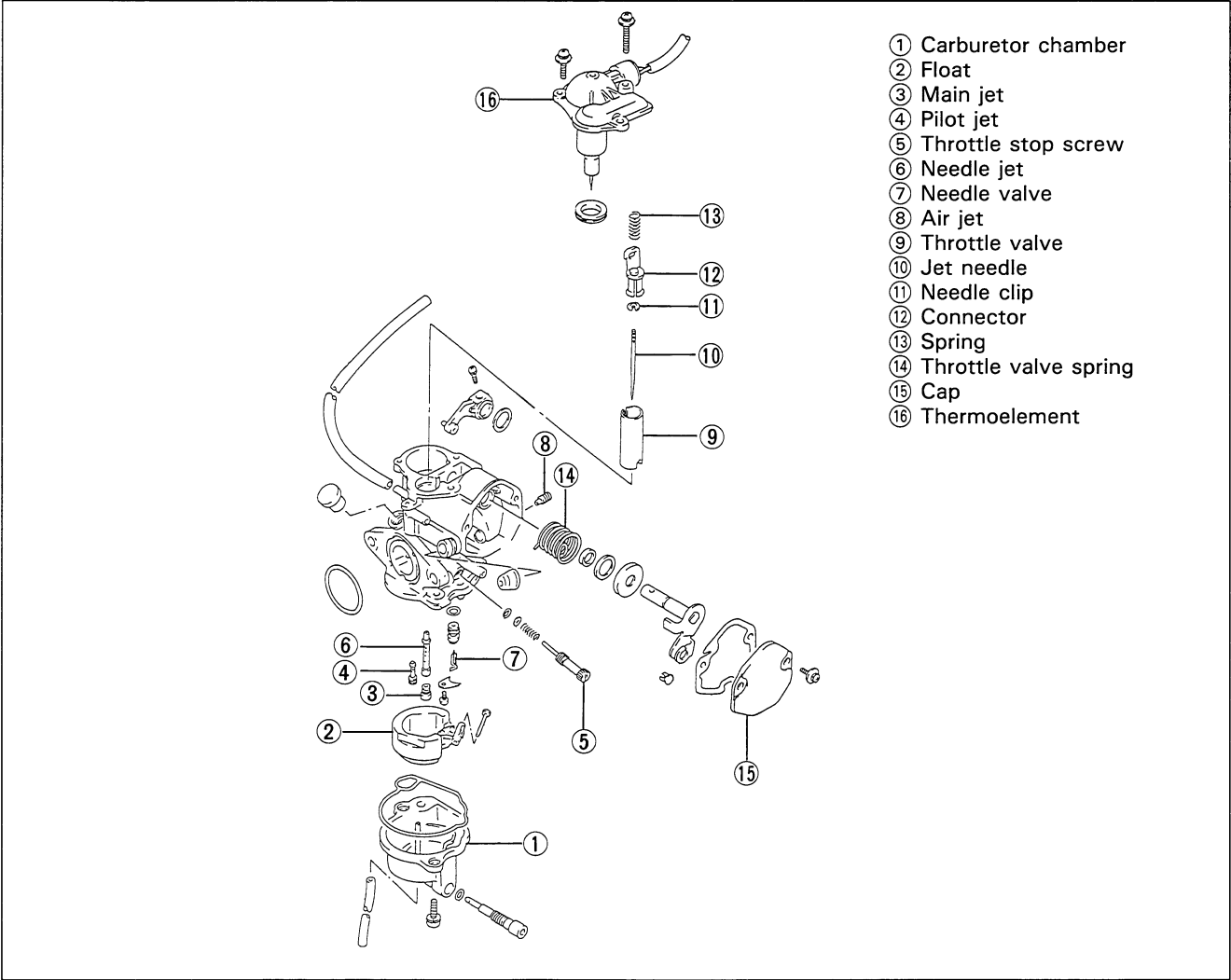

CARBURETOR I.D. No. **A**

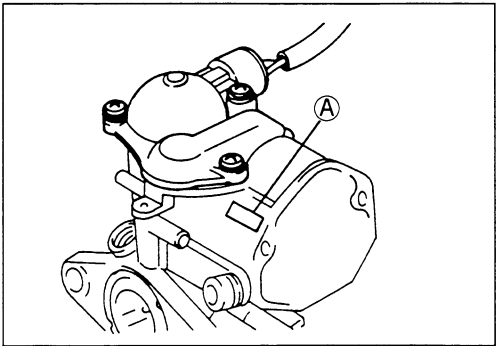

CARBURETOR SETTING

Refer to page 7-24.

REMOVAL

- Remove the lower side cover. (Refer to page 5-2.)
- Disconnect the throttle cable. (Refer to page 3-2.)
- Remove the air cleaner.
- Remove the carburetor by removing the mounting bolts ① .

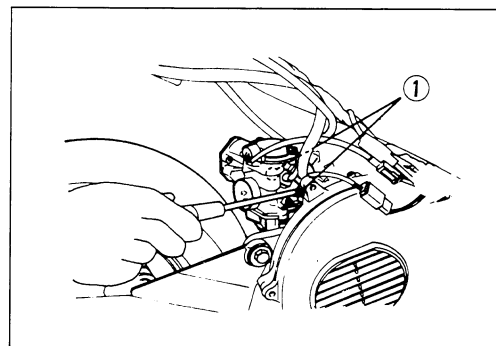

DISASSEMBLY

- Remove the thermoelement ② .

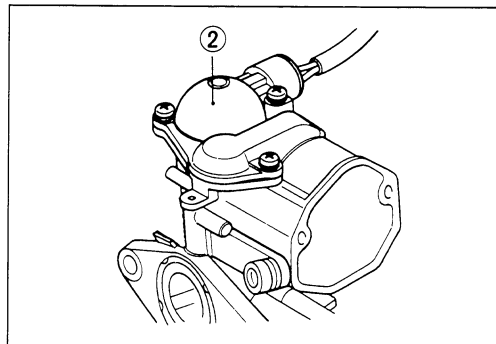

⚠ CAUTION

Do not disassemble the thermoelement assembly. It is not serviceable.

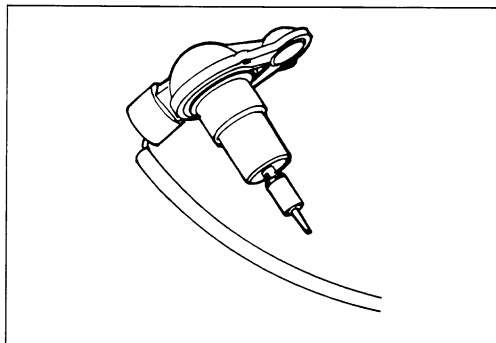

- Remove the throttle shaft ③ by removing the screw ④ .
- Remove the throttle lever ⑤ and throttle valve ⑥ .

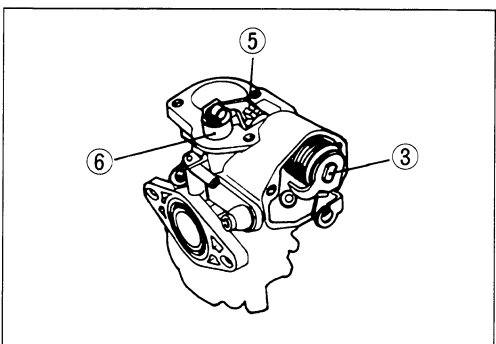
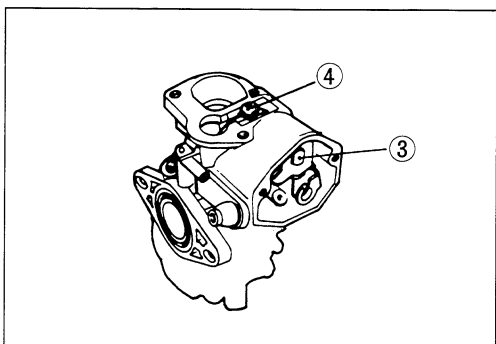

- Separate the jet needle and throttle valve.

NOTE:

To remove the jet needle, pushing the nail of the connector by the flatheaded screwdriver pull the connector out.

CAUTION

Take care not to damage the throttle valve by the screwdriver.

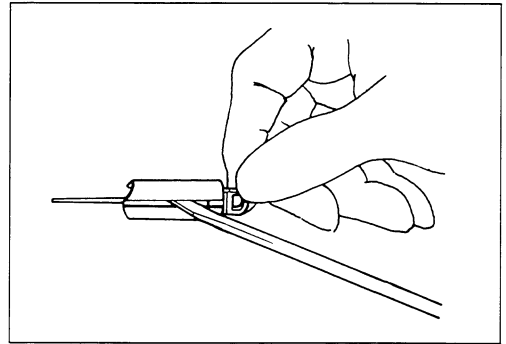

- Remove the float chamber ① .

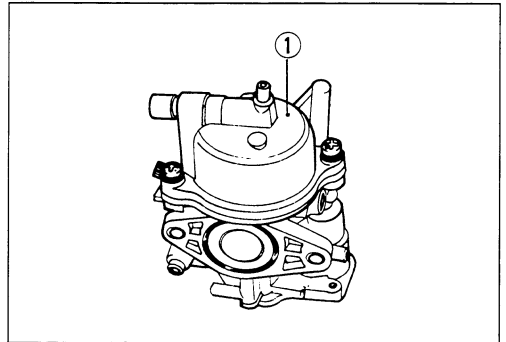

- Remove the float ② with needle valve ③ by removing the float pin ④ .

CAUTION

When removing the float pin, be careful not to damage the carburetor body and float.

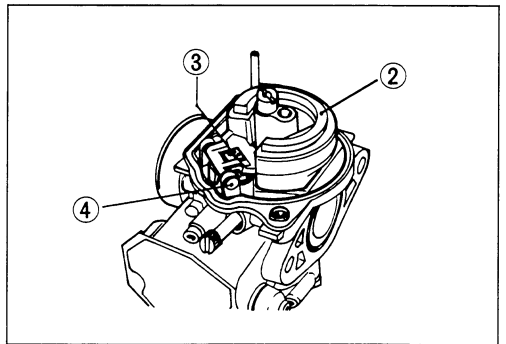

- Remove the main jet ⑤ , pilot jet ⑥ and pilot air jet ⑦ .
- Remove the needle jet ⑧ from the bore side.

CAUTION

To clean jets apply air pressure. Do not use a wire etc.

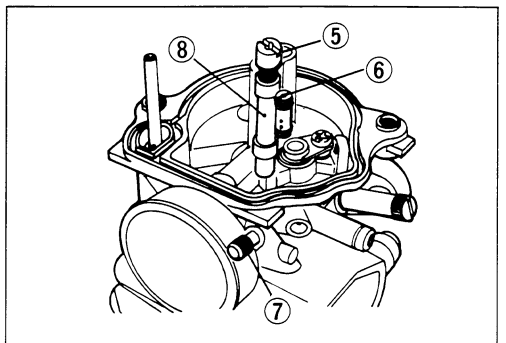

- Remove the throttle stop screw ⑨ and valve seat ⑩ .

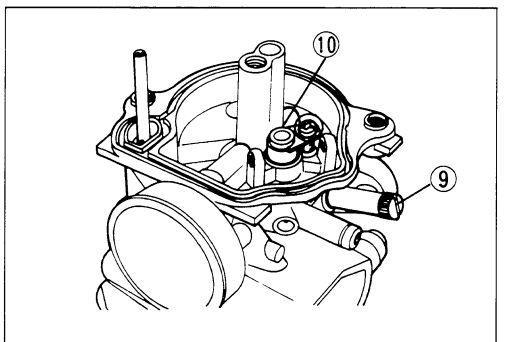

INSPECTION

Check the following items for any damage or clogging.

- * Main jet
- * Throttle valve
- * Pilot jet
- * Float
- * Needle jet
- * Needle valve
- * Thermoelement (Refer to page 6-15.)

NEEDLE VALVE INSPECTION

If foreign matter is caught between the valve seat and the needle, the gasoline will continue flowing and cause it to overflow. If the seat and needle are worn out beyond the permissible limits, similar trouble will occur. Conversely, if the needle sticks, the gasoline will not flow into the float chamber.

Remove the carburetor, float chamber and floats, and clean the float chamber and float parts with gasoline. If the needle is worn as shown in the illustration, replace it together with the valve seat. Clean the fuel passage of the mixing chamber with compressed air.

FLOAT HEIGHT ADJUSTMENT

To check the float height, invert the carburetor body, holding the float arm pin so that the pin will not slip off. Gradually lower the float and observe the clearance between the float tongue and the end of needle valve. When the tongue just begins to contact the end of needle valve, stop lowering the float and hold it. Then, measure the float height from the float chamber mating surface using a caliper as shown.

NOTE:

When measuring the height, remove the O-ring.

 **09900-20101: Vernier calipers**

Float height A : 17.2 ± 1.0 mm (0.68 ± 0.04 in)

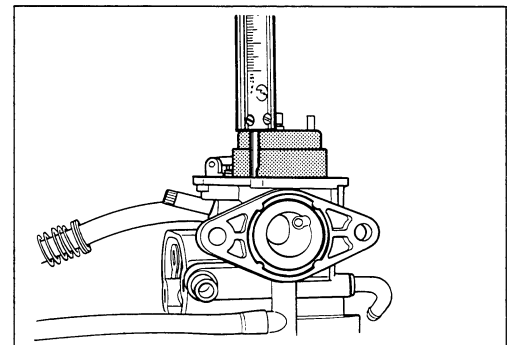
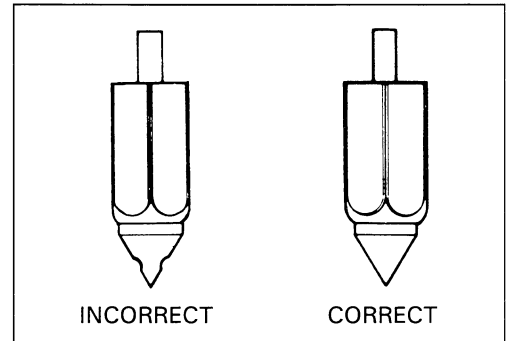

RESSEMBLY AND REMOUNTING

Reassemble and remount the carburetor in the reverse order of removal and disassembly, and also carry out the following steps:

- Fit the connector rail ① in throttle valve groove ② reliable.

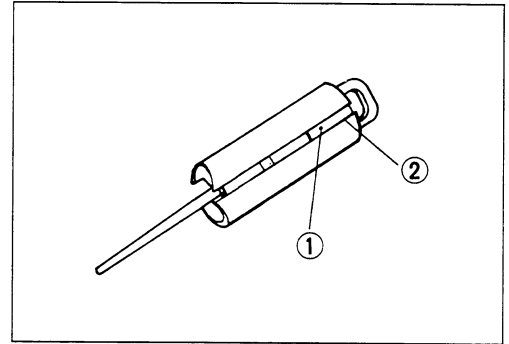

- Install the spring ③ and ring ④ as shown in the illustration.
- Set the hole ① of connector and projection ② of throttle valve arm.

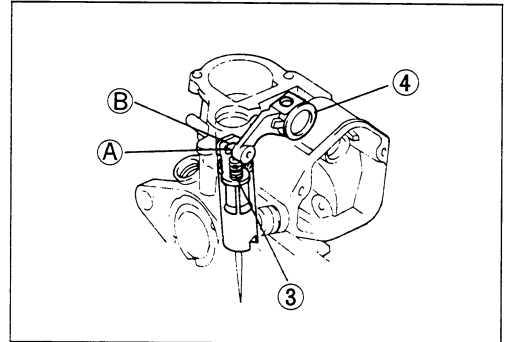

- Install the spring ⑤ and spring guide ⑥ on throttle shaft.
- Put the spring tip ③ on arm.

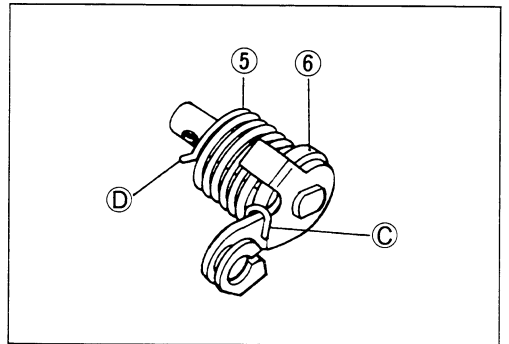

- Hook the end ④ of the spring to the carburetor hook ⑤. Then turning the arm clockwise assemble the throttle shaft into the carburetor body.
- Tighten the screw ⑦.

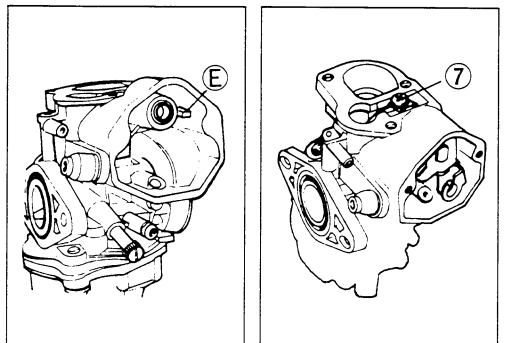

- After remounting the carburetor, the following adjustments are necessary.
 - * Throttle cable play Refer to page 2-6.
 - * Engine idle r/min Refer to page 2-6.

OIL PUMP

AIR BLEEDING

Whenever evidence is noted of some air having leaked into the oil pipe from the oil tank in a machine brought in for servicing, or if the oil pump has to be removed for servicing, be sure to carry out an air bleeding operation with the oil pump in place before returning the machine to the user. To bleed air, hold the machine in standstill condition. Loosen the screw ① to let out air and after making sure that the trapped air has all been bled, tighten the screw good and hard.

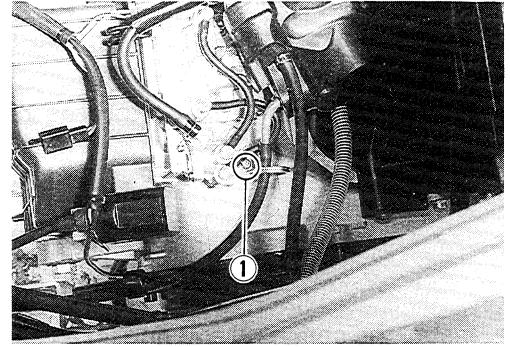

CHECKING OIL PUMP

Use the special tool, to check the pump for capacity by measuring the amount of oil the pump draws during the specified interval.

- Remove the left side cover.
- Have the tool filled with SUZUKI CCI SUPER OIL and connect it to the suction side of the pump.
- Run the engine at 3 000 r/min.
- Holding engine speed at the same 3 000 r/min., and let the pump draw for 5 minutes. For this operation, the reading taken on the device should be 0.9–1.1 ml.

 **09900-21602: CCI oil gauge**

**Oil discharge amount: 0.9–1.1 ml at 3 000 r/min.
for 5 minutes.**

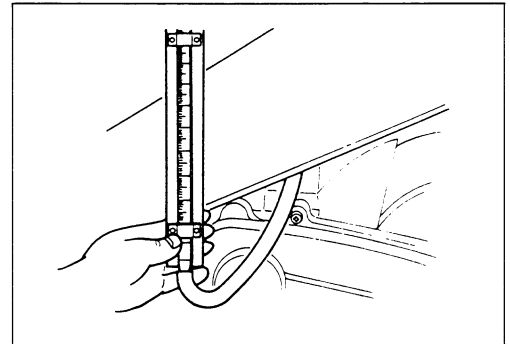

CAUTION

During this inspection, strictly follow the following points.

- * **The machine should be rested on the center stand.**
- * **Do not touch the rear wheel while running the engine.**

NOTE:

Adjust the idle r/min after checking the oil pump. (Refer to page 2-6.)

CHASSIS

CONTENTS

LEG SHIELD AND FRAME COVER	5- 1
LEG SHIELD REMOVAL	5- 2
FRAME COVER REMOVAL	5- 3
LEG SHIELD AND FRAME COVER REMOUNTING	5- 3
FRONT WHEEL	5- 4
REMOVAL	5- 4
INSPECTION AND DISASSEMBLY	5- 5
REASSEMBLY AND REMOUNTING	5- 6
FRONT BRAKE	5- 8
BRAKE PAD REPLACEMENT	5- 9
BRAKE FLUID REPLACEMENT	5- 9
CALIPER REMOVAL AND DISASSEMBLY	5-10
CALIPER INSPECTION	5-11
CALIPER REASSEMBLY AND REMOUNTING	5-11
DISC INSPECTION	5-12
MASTER CYLINDER REMOVAL AND DISASSEMBLY	5-12
MASTER CYLINDER INSPECTION	5-13
MASTER CYLINDER REASSEMBLY AND REMOUNTING	5-14
FRONT FORK	5-15
REMOVAL AND DISASSEMBLY	5-15
INSPECTION	5-17
REASSEMBLY AND REMOUNTING	5-18
HANDLEBAR COVER	5-20
REMOVAL	5-21
REMOUNTING	5-21
STEERING STEM	5-22
REMOVAL AND DISASSEMBLY	5-22
INSPECTION	5-24
REASSEMBLY AND REMOUNTING	5-24
REAR WHEEL, BRAKE AND SHOCK ABSORBER	5-26
REMOVAL AND DISASSEMBLY	5-26
INSPECTION	5-27
REASSEMBLY AND REMOUNTING	5-28

LEG SHIELD AND FRAME COVER

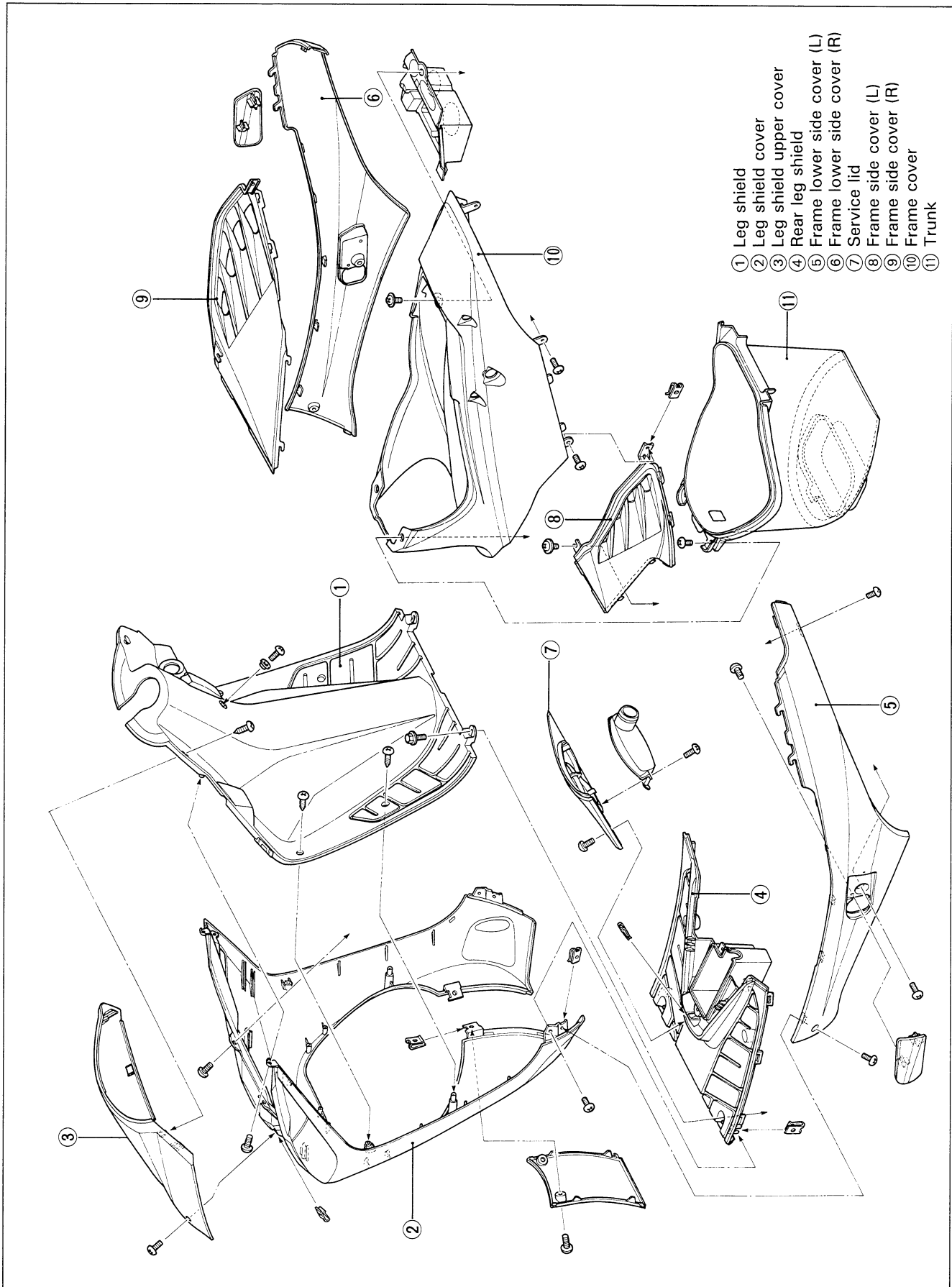

LEG SHIELD REMOVAL

- Remove the frame lower side covers ①.
- Remove the leg shield upper cover ②.
- Remove the leg shield cover ③.
- Remove the service lid ④.
- Remove the battery cover ⑤.
- Remove the battery ⑥.

⚠ CAUTION

Remove the \ominus lead wire first and \oplus lead wire last.

- Remove the frame cover. (Refer to page 5-3.)
- Remove the leg shield ⑦ and rear leg shield ⑧.

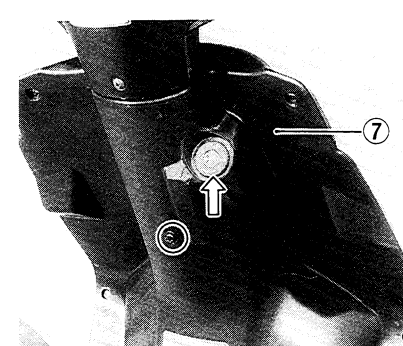
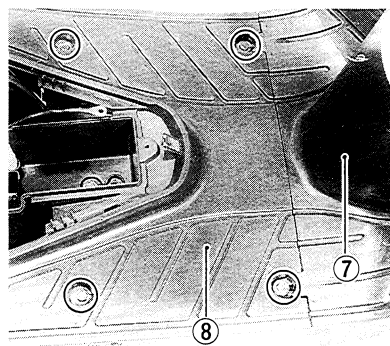
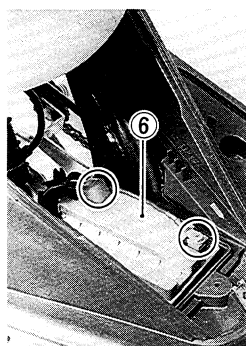
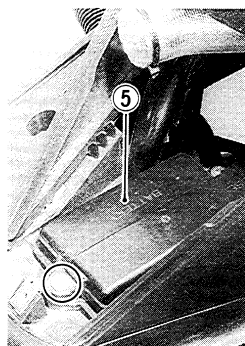
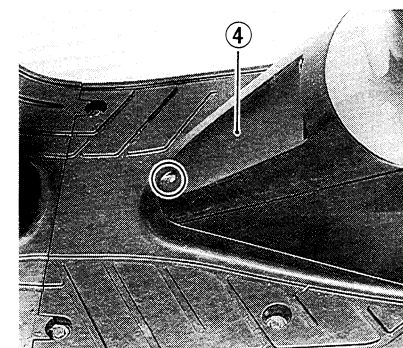
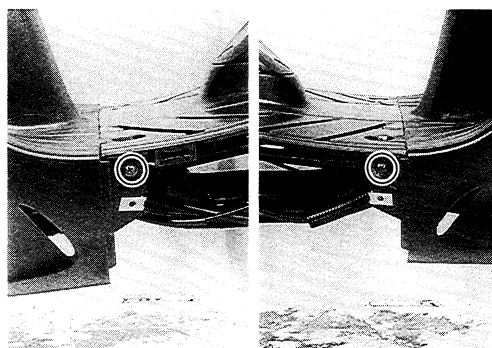
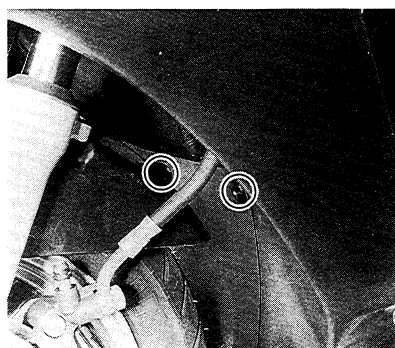
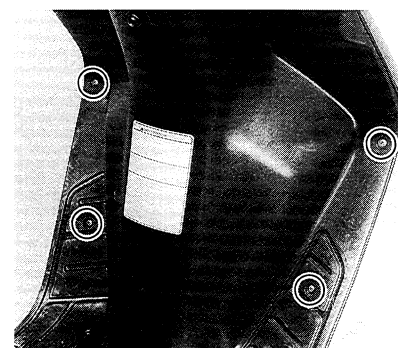
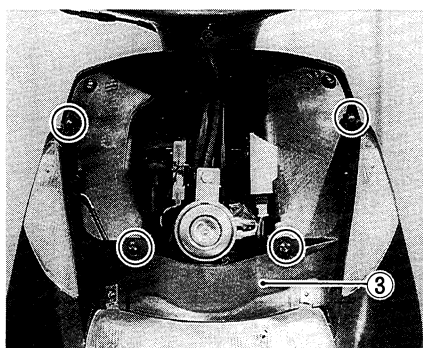
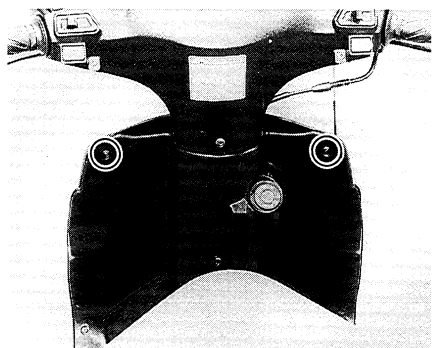
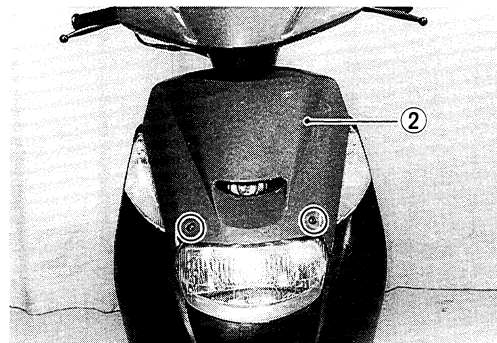
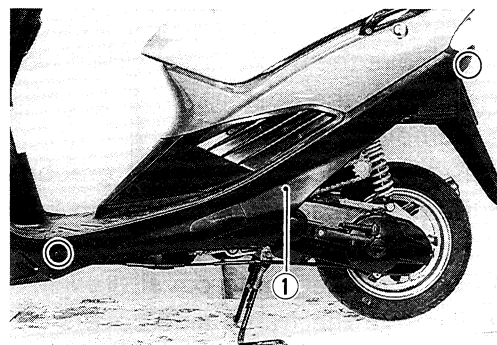

FRAME COVER REMOVAL

- Remove the frame lower side covers. (Refer to page 5-2.)
- Remove the seat ①.
- Remove the trunk ②.
- Remove the right and left grabbers ③.
- Remove the rear combination light ④.
- Remove the service lid ⑤.
- Remove the frame cover ⑥.
- Remove the frame side covers ⑦.

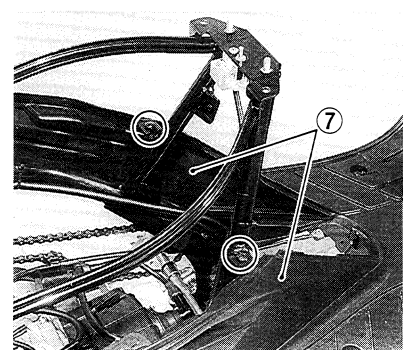
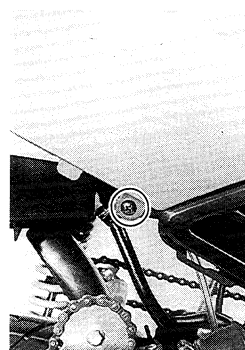
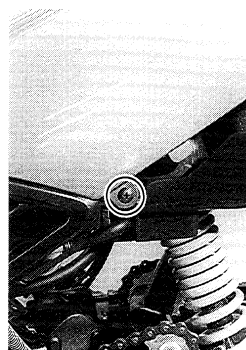
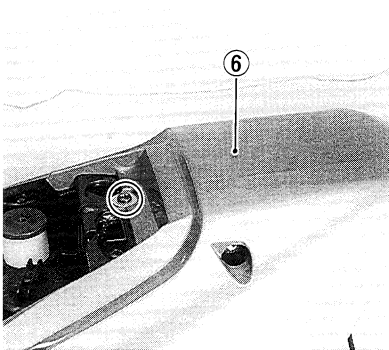
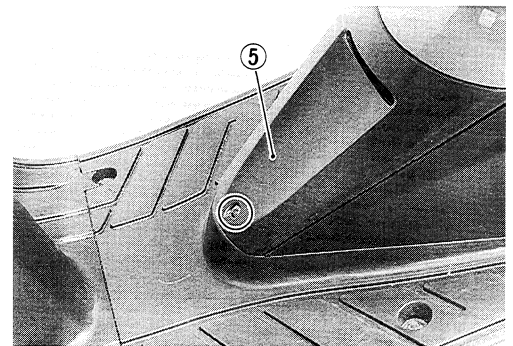
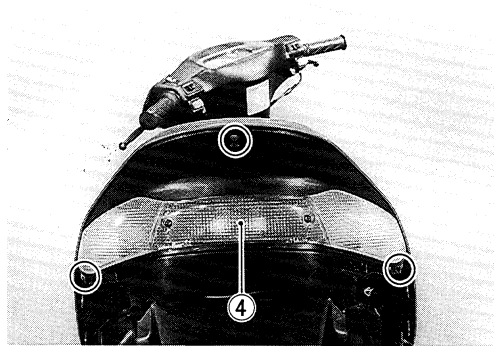
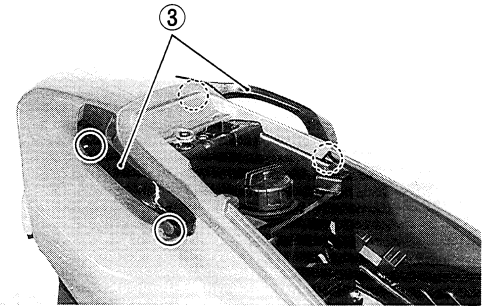
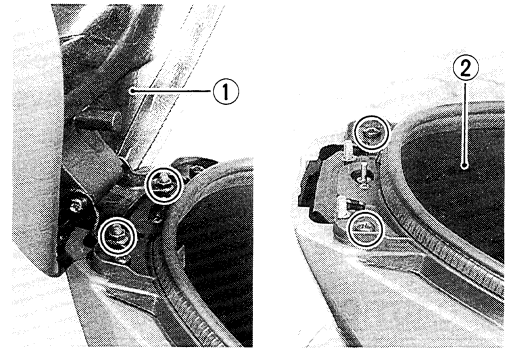

LEG SHIELD AND FRAME COVER REMOUNTING

- Remount the leg shield and frame covers in the reverse order of removal.

FRONT WHEEL

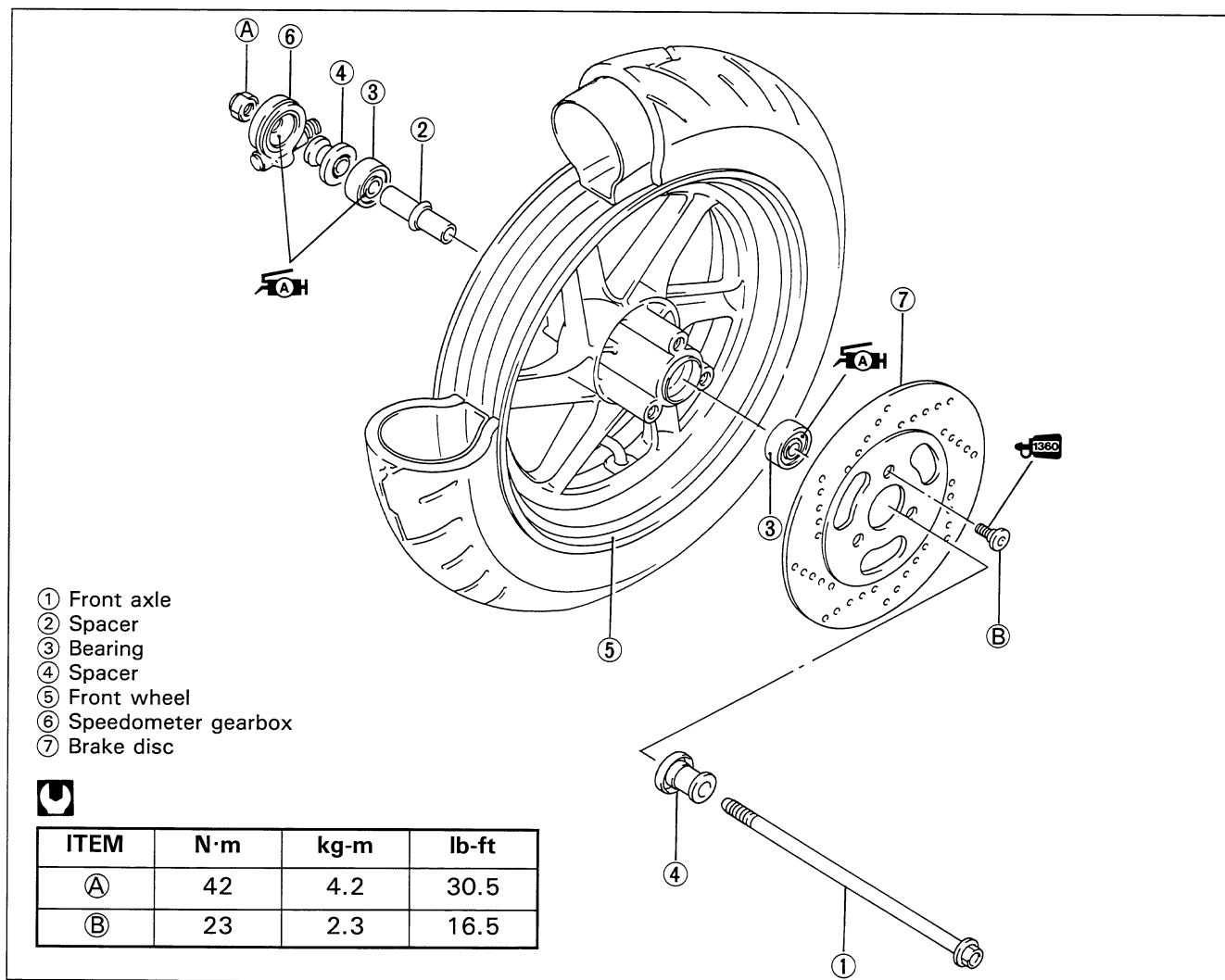

REMOVAL

- Remove the front brake caliper.
- Remove the front axle nut.
- Support the machine with block or jack.
- Remove the front wheel by removing the front axle.

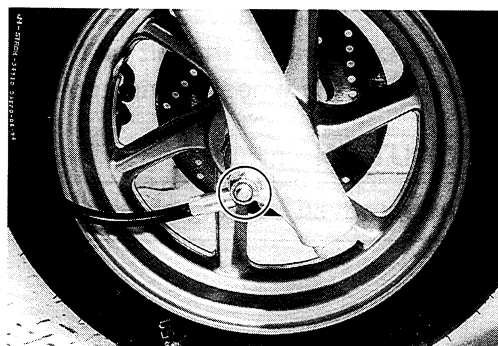
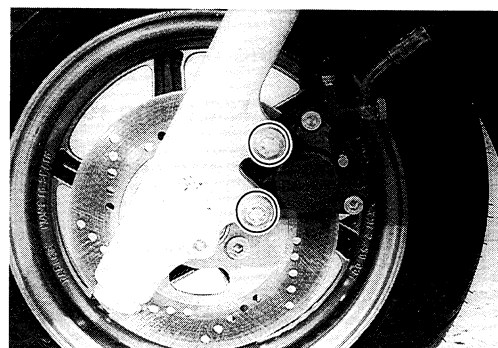

- Remove the brake disc from the wheel.

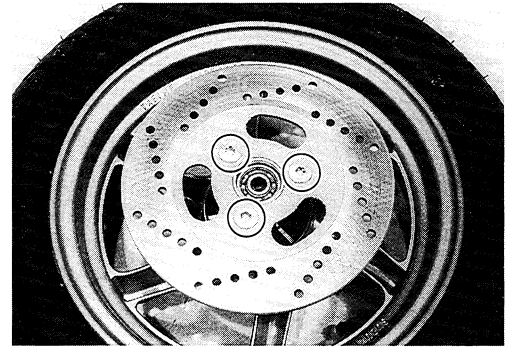

INSPECTION AND DISASSEMBLY

SPEEDOMETER GEARBOX DUST SEAL

Inspect the dust seal for damage.

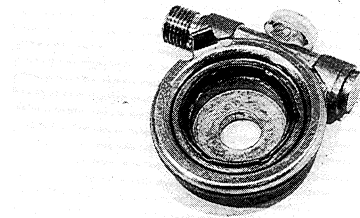

WHEEL BEARINGS

Inspect the play of wheel bearing inner ring by hand when installed in the wheel.

Rotate the inner ring by hand to inspect an abnormal noise and a smooth rotation. Replace the bearing if there is something unusual.

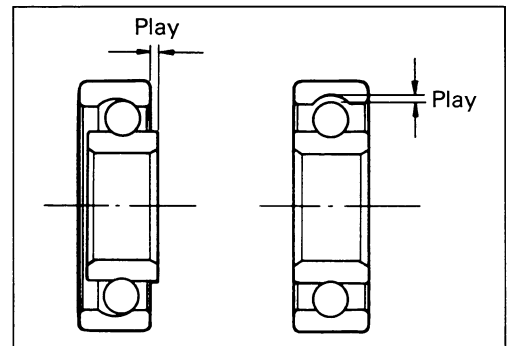

Drive out the right and left wheel bearings with the special tool in the following procedures.

TOOL 09941-50111: Bearing remover

- Insert the adapter into the wheel bearing.

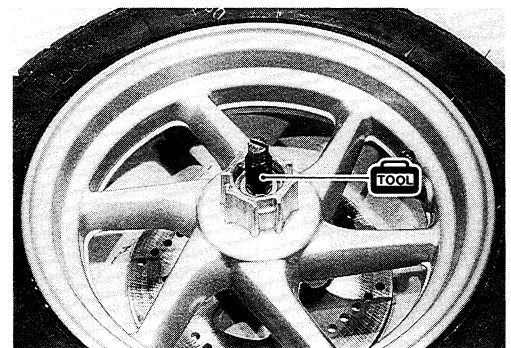

- After inserting the wedge bar from the opposite side, lock the wedge bar in the slit of the adapter.
- Drive out the wheel bearing by knocking the wedge bar.

CAUTION

The removed bearing should be replaced.

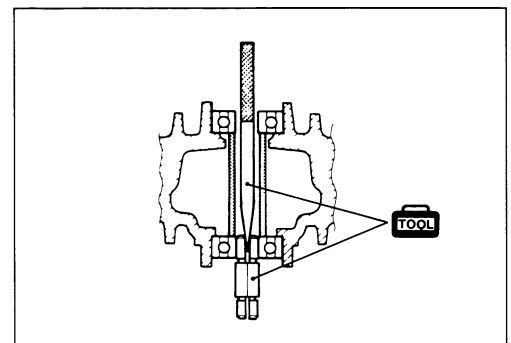

WHEEL

Make sure that the wheel runout checked as shown, does not exceed the service limit. An excessive runout is usually due to worn or loose wheel bearings and can be reduced by replacing the bearings. If bearing replacement fails to reduce the runout, replace the wheel.

Service Limit (Axial and Radial): 2.0 mm (0.08 in)

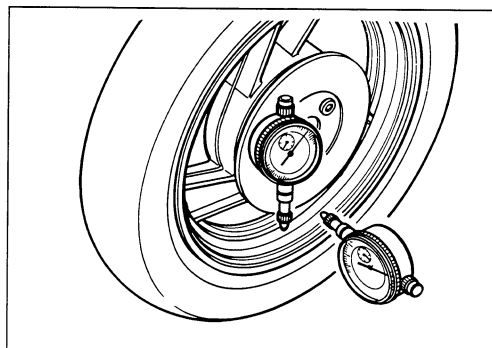
**TIRE**

Refer to page 2-10.

FRONT AXLE

Using a dial gauge, check the axle for runout. If the runout exceeds the limit, replace the axle.

Service Limit: 0.25 mm (0.010 in)

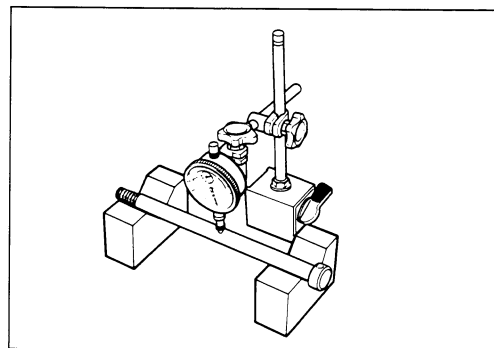
**REASSEMBLY AND REMOUNTING**

Reassemble and remount the front wheel in the reverse order of removal and disassembly. Pay attention to the following points:

WHEEL BEARING

- Apply grease to the bearing.

 **H99000-25010: SUZUKI SUPER GREASE "A"**

- Install the wheel bearings with the special tool.

 **09924-84521: Bearing installer set**

CAUTION

First install the wheel bearing for left side.

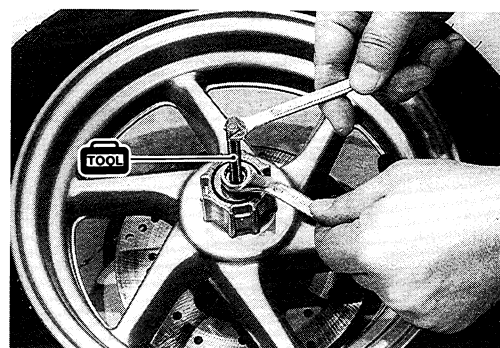
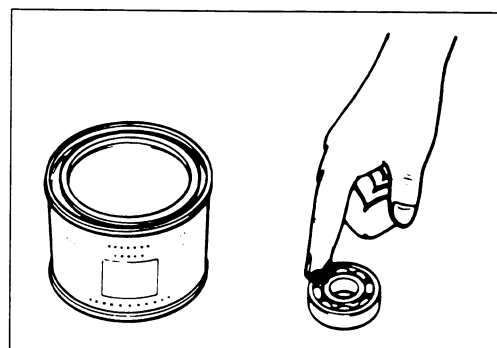

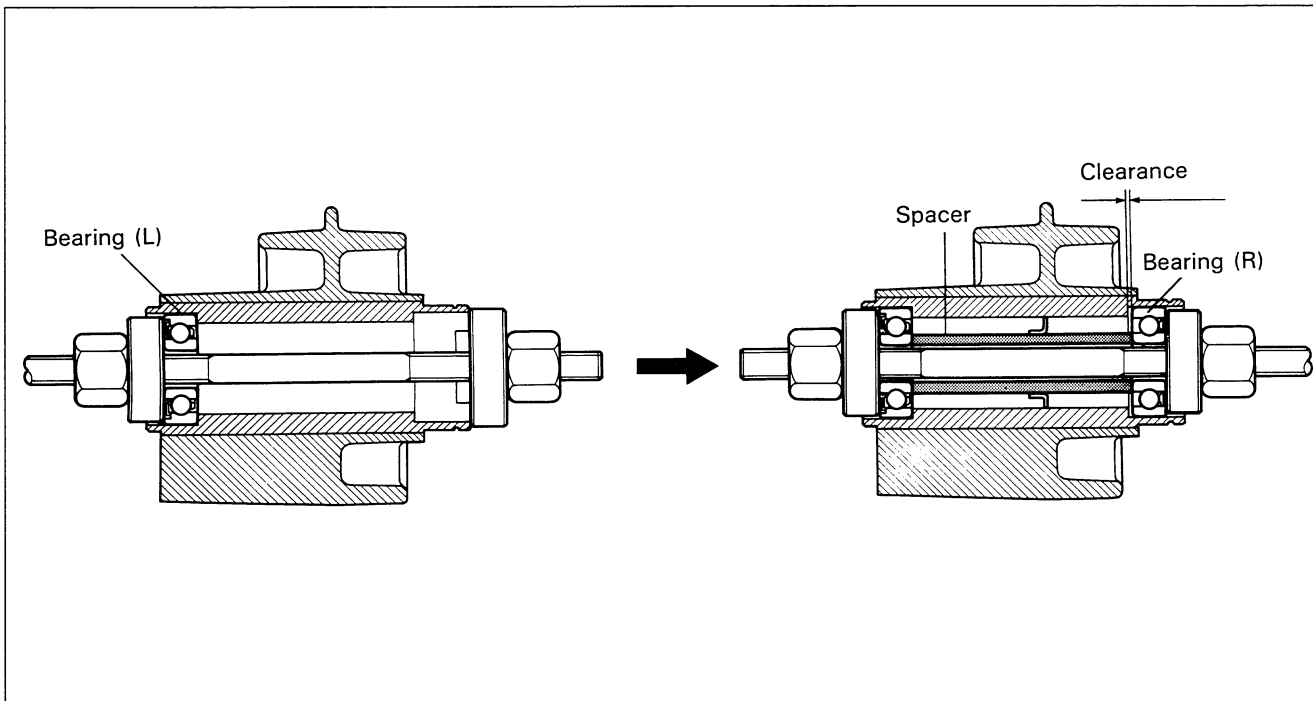

BRAKE DISC

- Make sure that the brake disc is clean and free of any greasy matter. Apply THREAD LOCK SUPER "1360" to the disc bolts and tighten them to the specified torque.

 99000-32130: THREAD LOCK SUPER "1360"

 Brake disc bolt: 23 N·m (2.3 kg·m, 16.5 lb-ft)

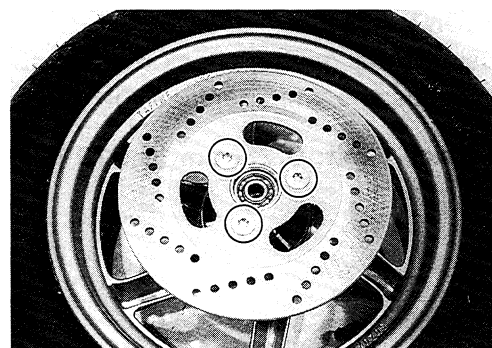

SPEEDOMETER GEARBOX

- Apply grease to the speedometer gearbox.

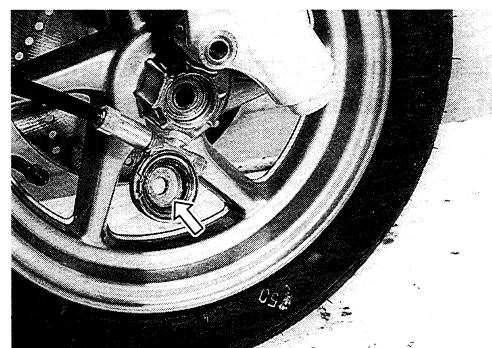

- Tighten the front axle nut ① and brake caliper mounting bolts ② to the specified torque.

 Front axle nut ①: 42 N·m (4.2 kg·m, 30.5 lb-ft)

Brake caliper bolt ②: 26 N·m (2.6 kg·m, 19.0 lb-ft)

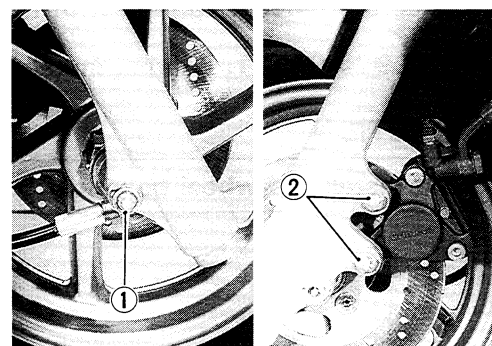

FRONT BRAKE

- ① Piston/cup set
- ② Brake hose
- ③ Pad
- ④ O-ring
- ⑤ Piston set

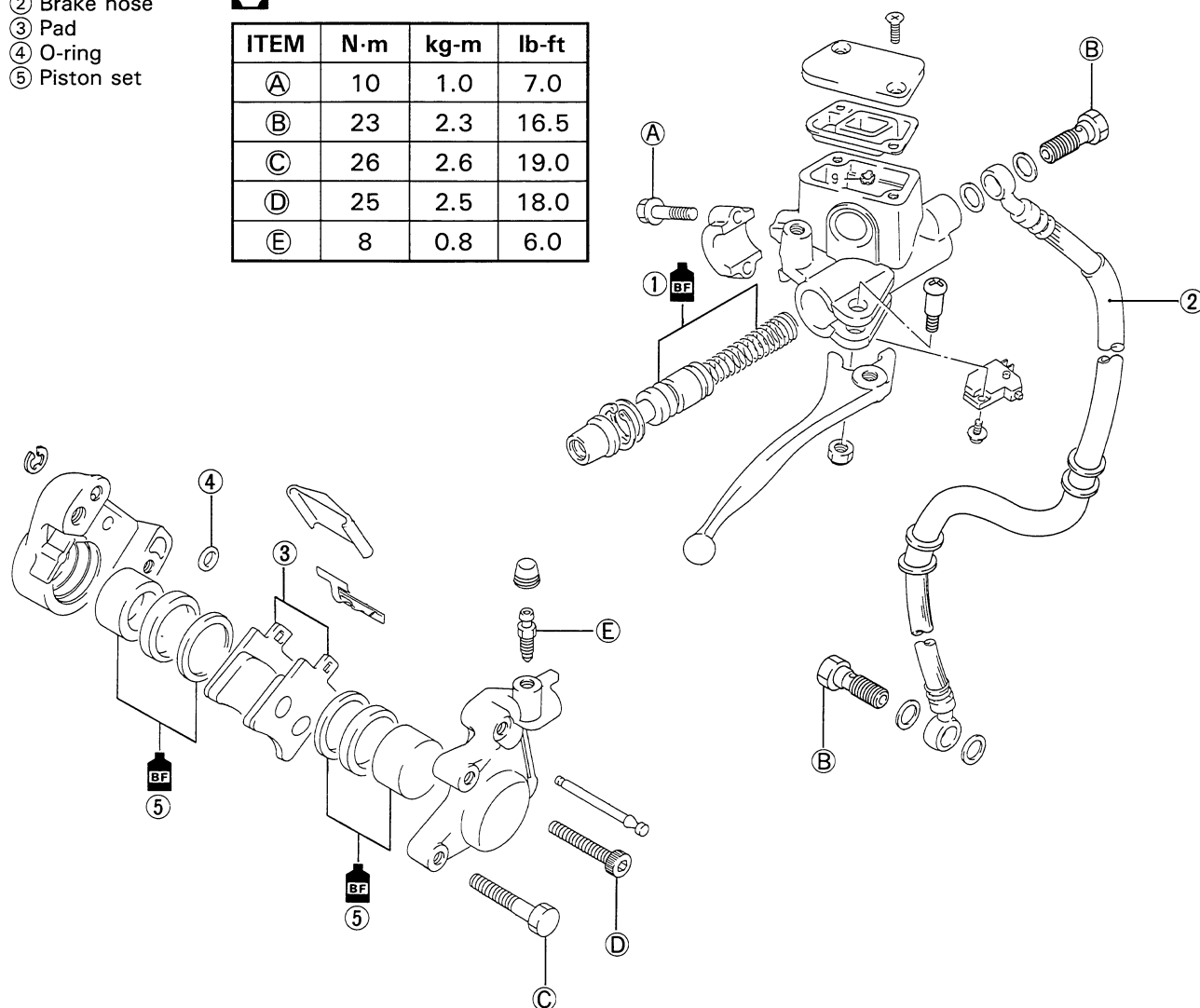

ITEM	N·m	kg·m	lb·ft
(A)	10	1.0	7.0
(B)	23	2.3	16.5
(C)	26	2.6	19.0
(D)	25	2.5	18.0
(E)	8	0.8	6.0

⚠ WARNING

- This brake system is filled with a ethylene glycol-based DOT 4 brake fluid. Do not use or mix different types of fluid such as silicone-based or petroleum-based.
- Do not use any brake fluid taken from old, used or unsealed containers. Never reuse brake fluid left over from the last servicing or stored for long periods.
- When storing the brake fluid, seal the container completely and keep away from children.
- When replenishing brake fluid, take care not to get dust into fluid.
- When washing brake components, use fresh brake fluid. Never use cleaning solvent.
- A contaminated brake disc or brake pad reduces braking performance. Discard contaminated pads and clean the disc with high quality brake cleaner or neutral detergent.

⚠ CAUTION

Handle brake fluid with care: the fluid reacts chemically with paint, plastics, rubber materials etc.

BRAKE PAD REPLACEMENT

- Remove the caliper by removing the caliper mounting bolts ①.

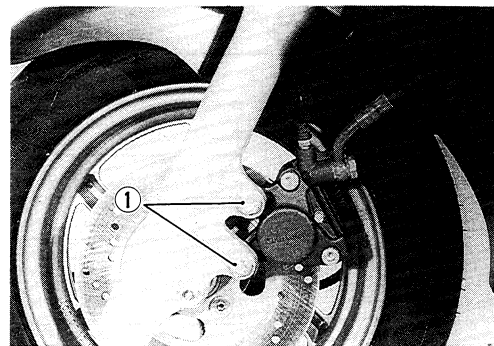

- Remove the pads by removing the E-ring ② and pad mounting pin ③.

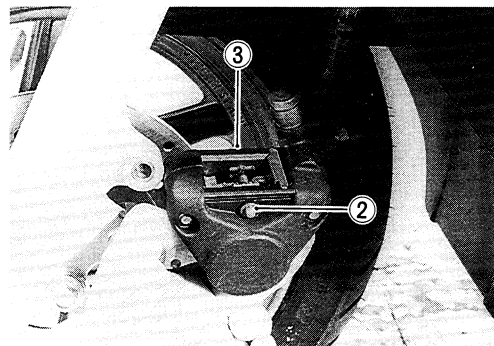

⚠ CAUTION

- * Replace the brake pad as a set, otherwise braking performance will be adversely affected.
- * Do not operate the front brake lever while dismantling the pads.

 Brake caliper mounting bolt: 26 N·m
(2.6 kg-m, 19.0 lb-ft)

BRAKE FLUID REPLACEMENT

- Place the motorcycle on a level surface and keep the handlebars straight.
- Remove the master cylinder reservoir cap and diaphragm.
- Suck up the old brake fluid as much as possible.
- Fill the reservoir with fresh brake fluid.

 Specification and classification: DOT 4

- Connect a clear hose ④ to the air bleeder valve ⑤, and insert the free end of hose into a receptacle.
- Loosen the bleeder valve and pump the brake lever until no more old brake fluid flows out of the bleeder valve.
- Close the air bleeder valve, and disconnect a clear hose. Fill the reservoir with fresh brake fluid to the upper end of the inspection window.

⚠ CAUTION

Bleed air in the brake fluid circuit. (Refer to page 2-8.)

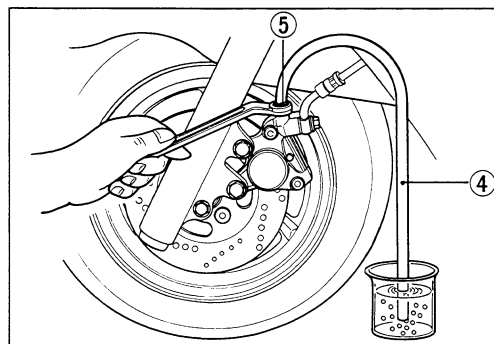
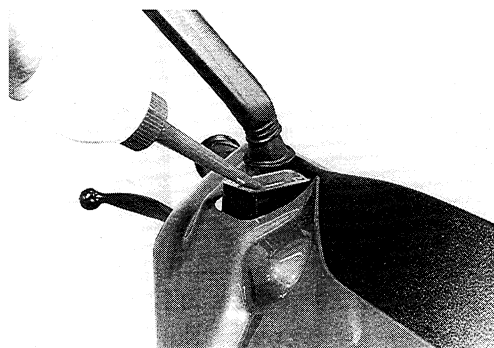

CALIPER REMOVAL AND DISASSEMBLY

- Remove the brake hose union bolt and catch the brake fluid in a suitable receptacle.
- Remove the brake caliper.

⚠ CAUTION

Never reuse the brake fluid left over from previous servicing and stored for long periods.

⚠ WARNING

Brake fluid, if it leaks, will interfere with safe running and discolor painted surfaces. Check the brake hose and hose joints for cracks and oil leakage.

NOTE:

Slightly loosen the caliper housing bolts ① to facilitate later disassembly before removing the caliper mounting bolts.

- Remove the pads. (Refer to page 5-9.)
- Remove the caliper housing bolts ①.

- Separate the caliper halves.
- Remove the O-ring ②.

⚠ CAUTION

Do not reuse the O-ring to prevent fluid leakage.

- Place a rag over the piston to prevent its popping out and push out the piston with an air gun.

⚠ CAUTION

Do not use high pressure air to prevent piston damage.

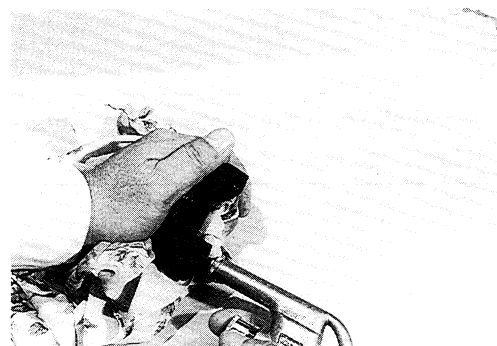
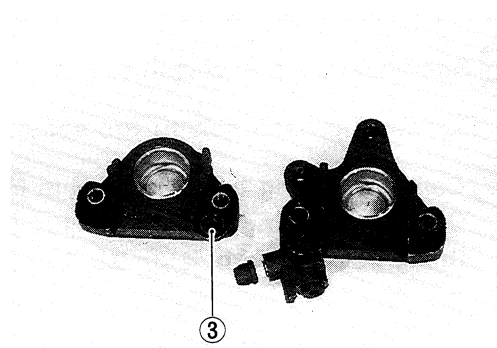
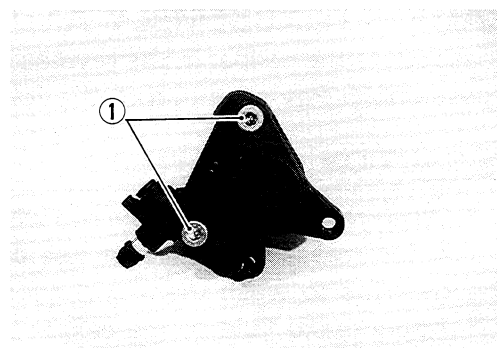
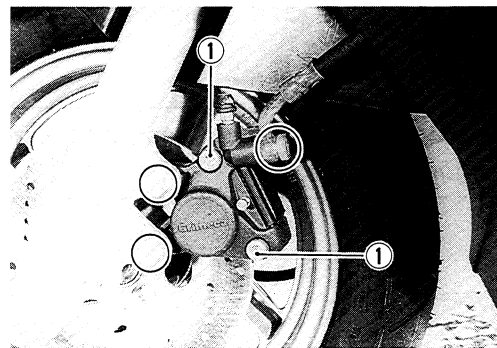

- Remove the dust seals and piston seals.

⚠ CAUTION

Do not reuse the dust seals and piston seals to prevent fluid leakage.

CALIPER INSPECTION

CALIPER

Inspect the caliper cylinder wall for nicks, scratches or other damage.

PISTON

Inspect the piston surface for any scratches or other damage.

CALIPER REASSEMBLY AND REMOUNTING

Reassemble the caliper in the reverse order of removal and disassembly. Pay attention to the following points.

⚠ CAUTION

- * Wash the caliper components with fresh brake fluid before reassembly. Never use cleaning solvent or gasoline to wash them.
- * Apply brake fluid to the caliper bore and piston to be inserted into the bore.

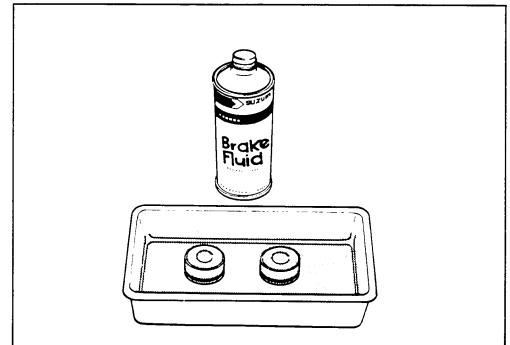

BF Specification and classification: DOT 4

- Tighten the each bolt to the specified torque.

- U** Caliper housing bolt ①: 25 N·m (2.5 kg-m, 18.0 lb-ft)
- Caliper mounting bolt ②: 26 N·m (2.6 kg-m, 19.0 lb-ft)
- Brake hose union bolt ③: 23 N·m (2.3 kg-m, 16.5 lb-ft)

NOTE:

Before remounting the caliper, push the piston all the way into the caliper.

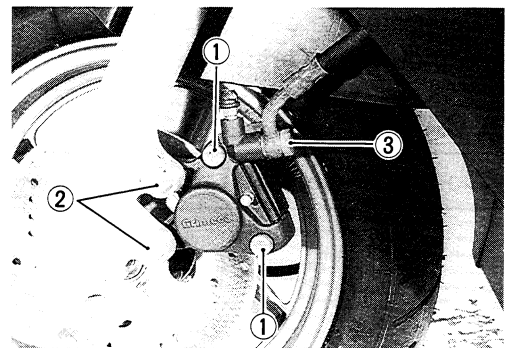

⚠ WARNING

Bleed air from the system after reassembling the caliper. (Refer to page 2-8.)

DISC INSPECTION

- Remove the front wheel. (Refer to page 5-4.)

Using a micrometer, check the disc for wear, its thickness can be checked with disc and wheel in place. The service limit for the thickness of the disc is shown below.

Service Limit: 3.5 mm (0.14 in)

 **09900-20205: Micrometer (0–25 mm)**

With the disc mounted on the wheel, check the disc for face runout with a dial gauge, as shown.

Service Limit: 0.30 mm (0.012 in)

 **09900-20606: Dial gauge (1/100 mm)**
09900-20701: Magnetic stand

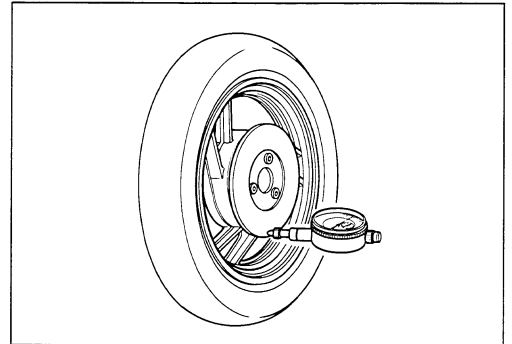
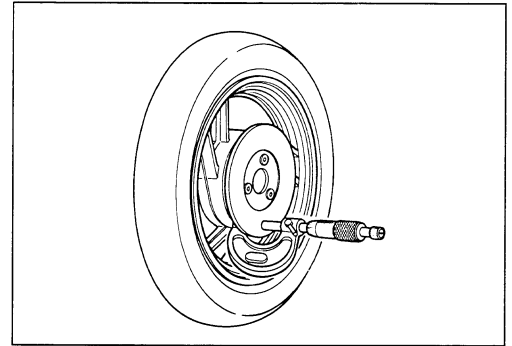

- Remove the disc. (Refer to page 5-5.)
- Install the disc. (Refer to page 5-7.)
- Install the front wheel.

MASTER CYLINDER REMOVAL AND DISASSEMBLY

- Remove the handlebar cover. (Refer to page 5-21.)
- Place a rag underneath the union bolt on the master cylinder to catch any spilled drops of brake fluid. Remove the union bolt ① and disconnect the brake hose/master cylinder joint.

CAUTION

Immediately and completely wipe off any brake fluid contacting any part of the motorcycle. The fluid reacts chemically with paint, plastics and rubber materials, etc. and will damage the severely.

- Disconnect the front brake light switch lead wires ②.
- Remove the master cylinder assembly by removing the clamp bolts ③.

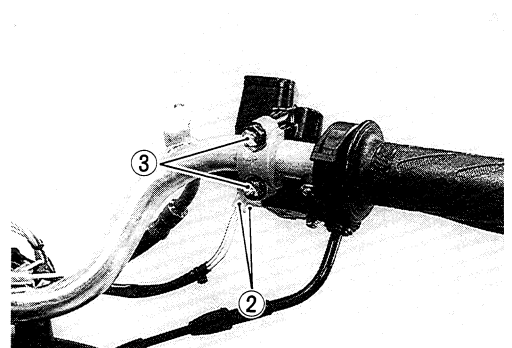
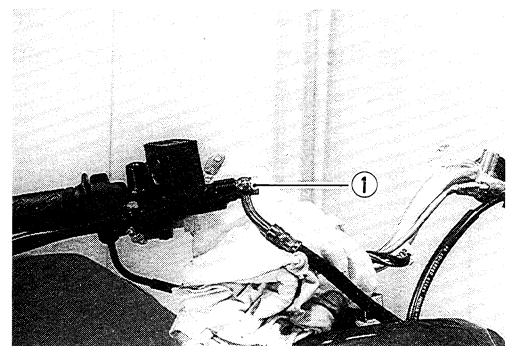

- Remove the brake lever and brake switch.

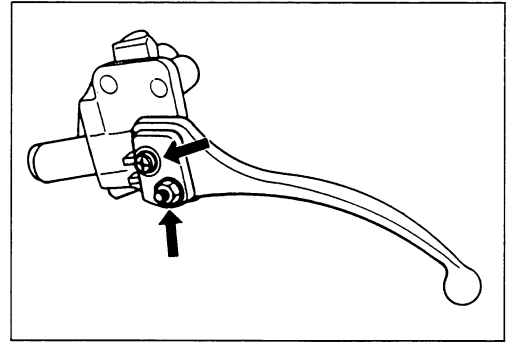

- Remove the dust boot.

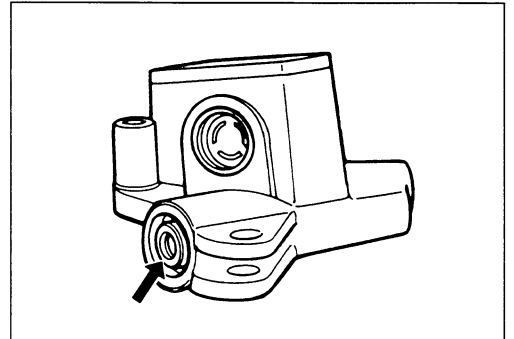

- Remove the circlip with the special tool.

 **09900-06108: Snap ring pliers**

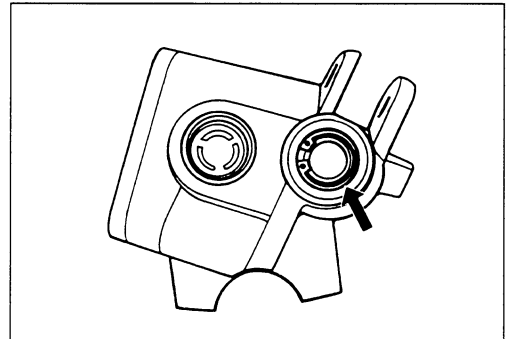

- Remove the piston/primary cap with return spring.
- Remove the reservoir cap and diaphragm.
- Drain brake fluid.

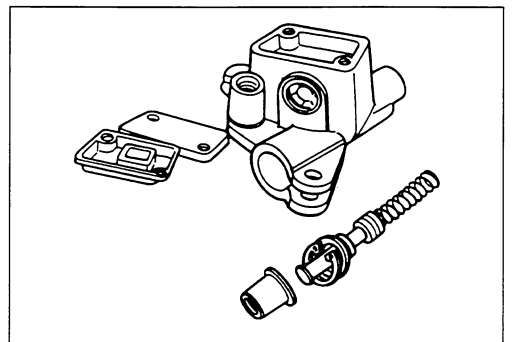

MASTER CYLINDER INSPECTION

Inspect the master cylinder bore for any scratches or other damage.

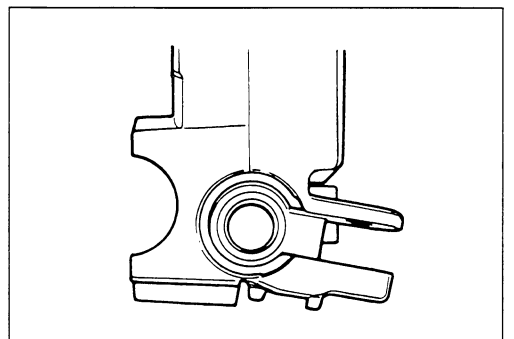

Inspect the piston surface for scratches or other damage. Inspect the primary cup and dust boot for wear or damage.

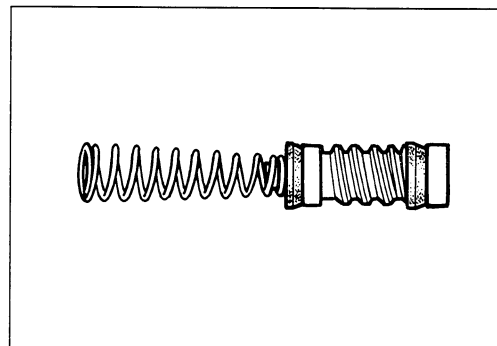

MASTER CYLINDER REASSEMBLY AND REMOUNTING

Reassemble and remount the master cylinder in the reverse order of removal and disassembly, and also carry out the following steps.

⚠ CAUTION

- * Wash the master cylinder components with fresh brake fluid before reassembly. Never use cleaning solvent or gasoline to wash them.
- * Apply brake fluid to the cylinder bore and all the internals to be inserted into the bore.

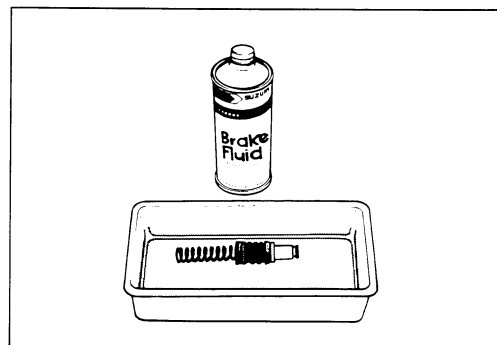

- Reassemble and remount the master cylinder. (Refer to page 5-8.)
- When remounting the master cylinder on the handlebars, first tighten the clamp bolt for upside.

⚠ WARNING

Bleed air after remounting the master cylinder. (Refer to page 2-8.)

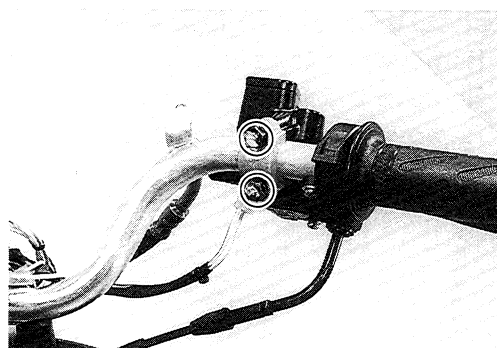

FRONT FORK

- ① Cap
- ② Stopper ring
- ③ Circlip
- ④ Spring
- ⑤ Damper
- ⑥ Inner tube
- ⑦ Dust seal
- ⑧ Stopper ring
- ⑨ Oil seal
- ⑩ Outer tube

ITEM	N·m	kg-m	lb-ft
Ⓐ	23	2.3	16.5
Ⓑ	20	2.0	14.5

REMOVAL AND DISASSEMBLY

- Remove the leg shield cover. (Refer to page 5-2.)
- Remove the front wheel. (Refer to page 5-4.)
- Remove the front fender and fender mounting brace.

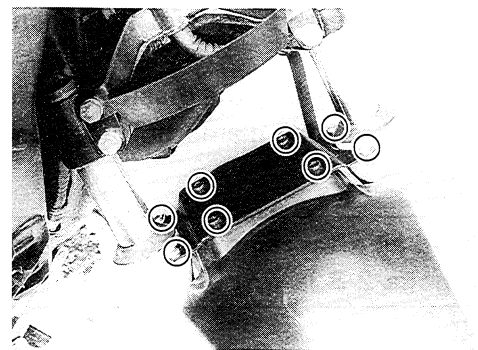

- Loosen the front fork clamp bolts ①.
- Remove the caps ②.

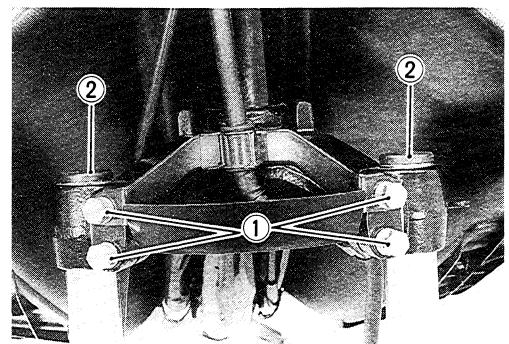

- Remove the front fork by removing the stopper ring ①.

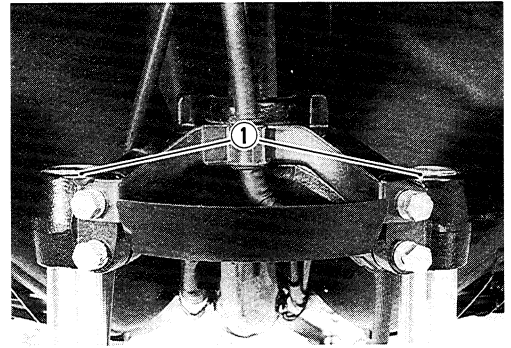

- Remove the stopper ring ②, spring seat ③, washer ④ and spring ⑤.

NOTE:

When removing the stopper ring ②, push the spring seat ③ inward to remove spring pressure from the stopper ring ②.

CAUTION

The removed stopper ring ② should be replaced with a new one.

- Invert the front fork and stroke it several times to let out fork oil. Under the inverted condition of front fork, drain oil to hold it for few minutes.

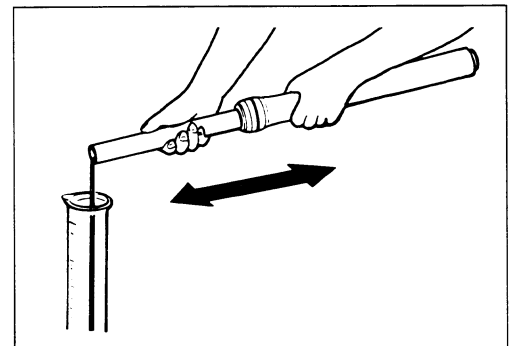
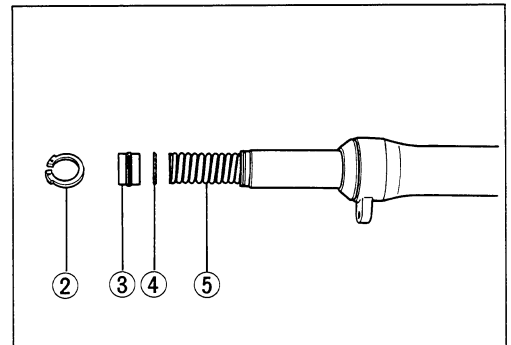

- Remove the dust seal ⑥.

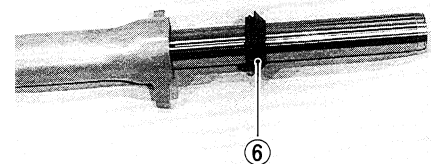

- Remove the damper rod bolt with the special tools and 6-mm hexagon wrench.

TOOL 09940-34520: "T" handle
 09940-34561: Attachment "D"

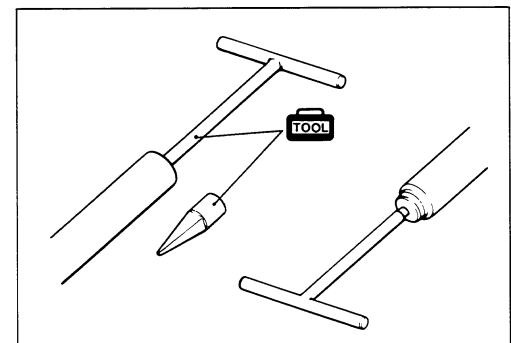

5-17 CHASSIS

- Remove the inner tube with damper rod.

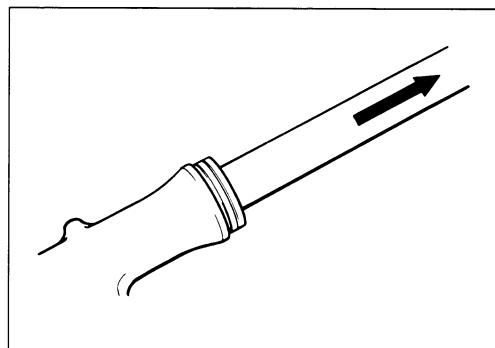

- Remove the stopper ring ① and oil seal ②.

⚠ CAUTION

The removed oil seal should be replaced with a new one.

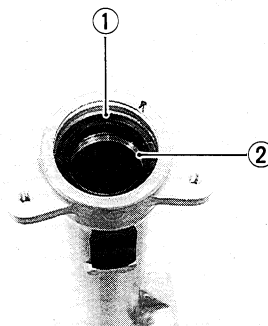

INSPECTION

FORK SPRING

Measure the fork spring free length. If it is shorter than the service limit, replace it with a new one.

Service Limit: 237.1 mm (9.3 in)

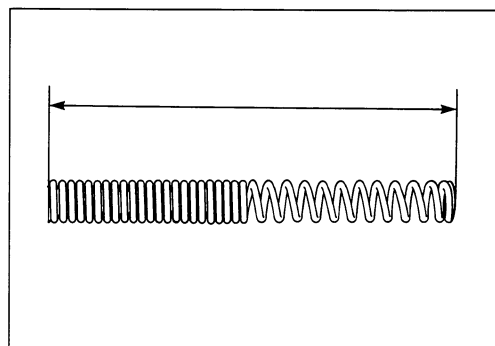

INNER AND OUTER TUBES

Inspect the inner tube sliding surface and outer tube sliding surface for any scuffing.

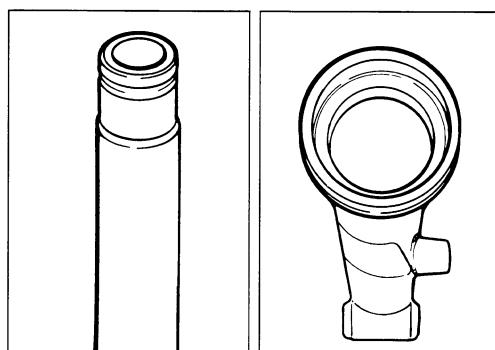

DAMPER ROD RING

Inspect the damper rod ring for wear or damage.

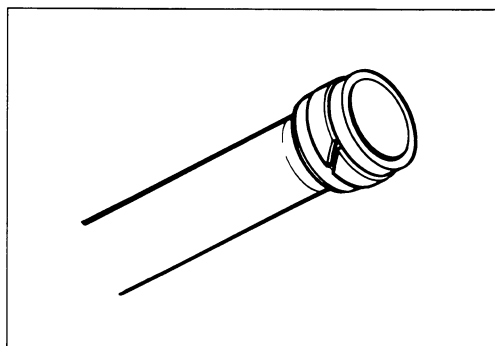

REASSEMBLY AND REMOUNTING

Reassemble and remount the front fork in the reverse order of removal and disassembly. Pay attention to the following points:

DAMPER ROD BOLT

- Tighten the damper rod bolt to the specified torque with the special tools and 6-mm hexagon wrench.

 Damper rod bolt: 20 N·m (2.0 kg-m, 14.5 lb-ft)

 09940-34520: "T" handle
09940-34561: Attachment "D"

CAUTION

Use a new damper bolt gasket.

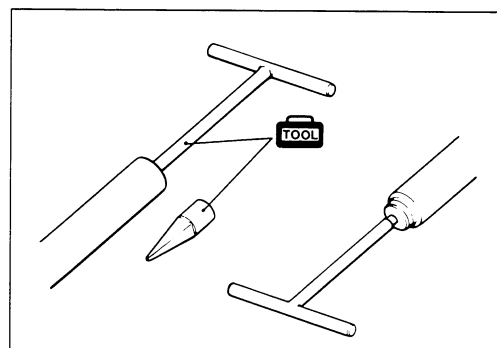

OIL SEAL

- Install the oil seal with the special tool.

 09940-52860: Front fork oil seal installer

- Install the oil seal stopper ring ①.

CAUTION

Make sure that the oil seal stopper ring ① fitted securely.

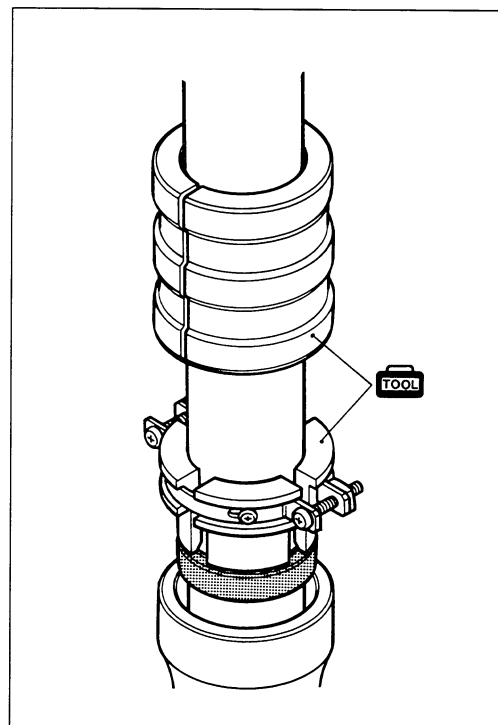

FORK OIL

- Pour specified fork oil into the inner tube.

 Fork oil type: Fork oil # 10
99000-99044-10G: SUZUKI FORK OIL # 10

Capacity (each leg): 96 ml (3.2/3.4 US/Imp oz)

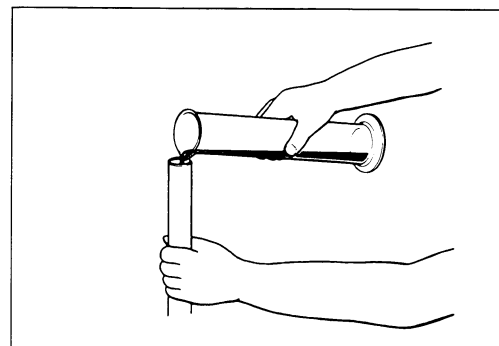

5-19 CHASSIS

- Hold the front fork vertical and adjust fork oil level with the special tool.

TOOL 09943-74111: Fork oil level gauge

Oil level: 64 mm (2.5 in)

NOTE:

When adjusting the oil level, remove the fork spring and compress the inner tube fully.

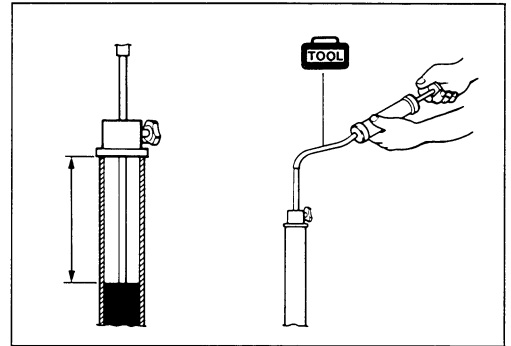

FORK SPRING

- Install the fork spring close pitch side to upper as shown in photo.

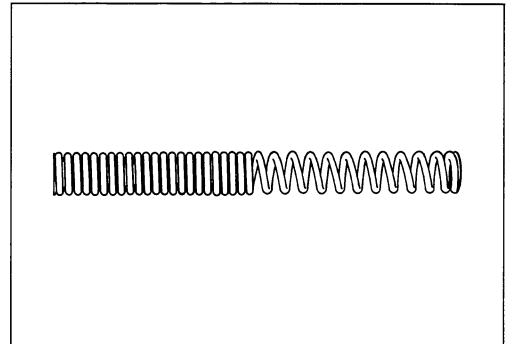

STOPPER RING

- Install the stopper ring ① into the ring groove.

CAUTION

- * Use a new stopper ring.
- * After installing the stopper ring, always insure that it is completely seated in its groove and securely fitted.

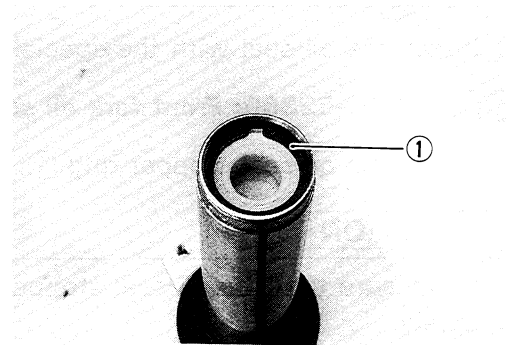

- Install the new stopper rings ② to the ring groove on the front fork after remounting the front fork assembly to the steering bracket.

CAUTION

Use a new stopper rings.

- Tighten the front fork clamp bolts ③ to the specified torque.

U Front fork clamp bolt: 23 N·m (2.3 kg-m, 16.5 lb-ft)

NOTE:

Before tighten the fender brace mounting screws, move the front fork up and down 4 or 5 times.

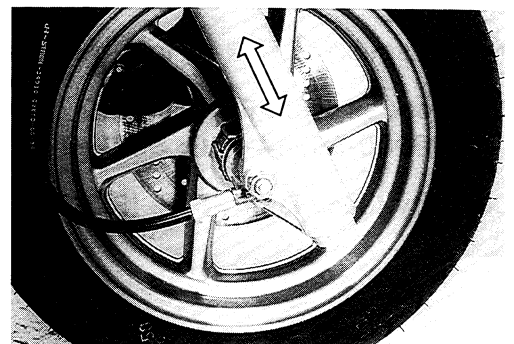
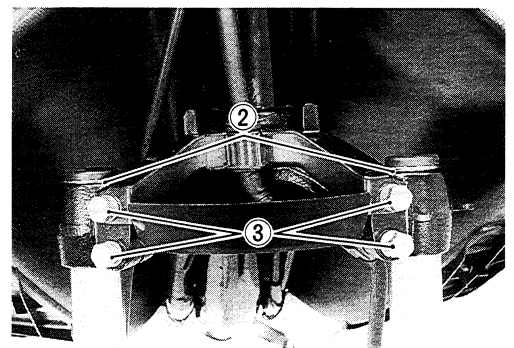

HANDLEBAR COVER

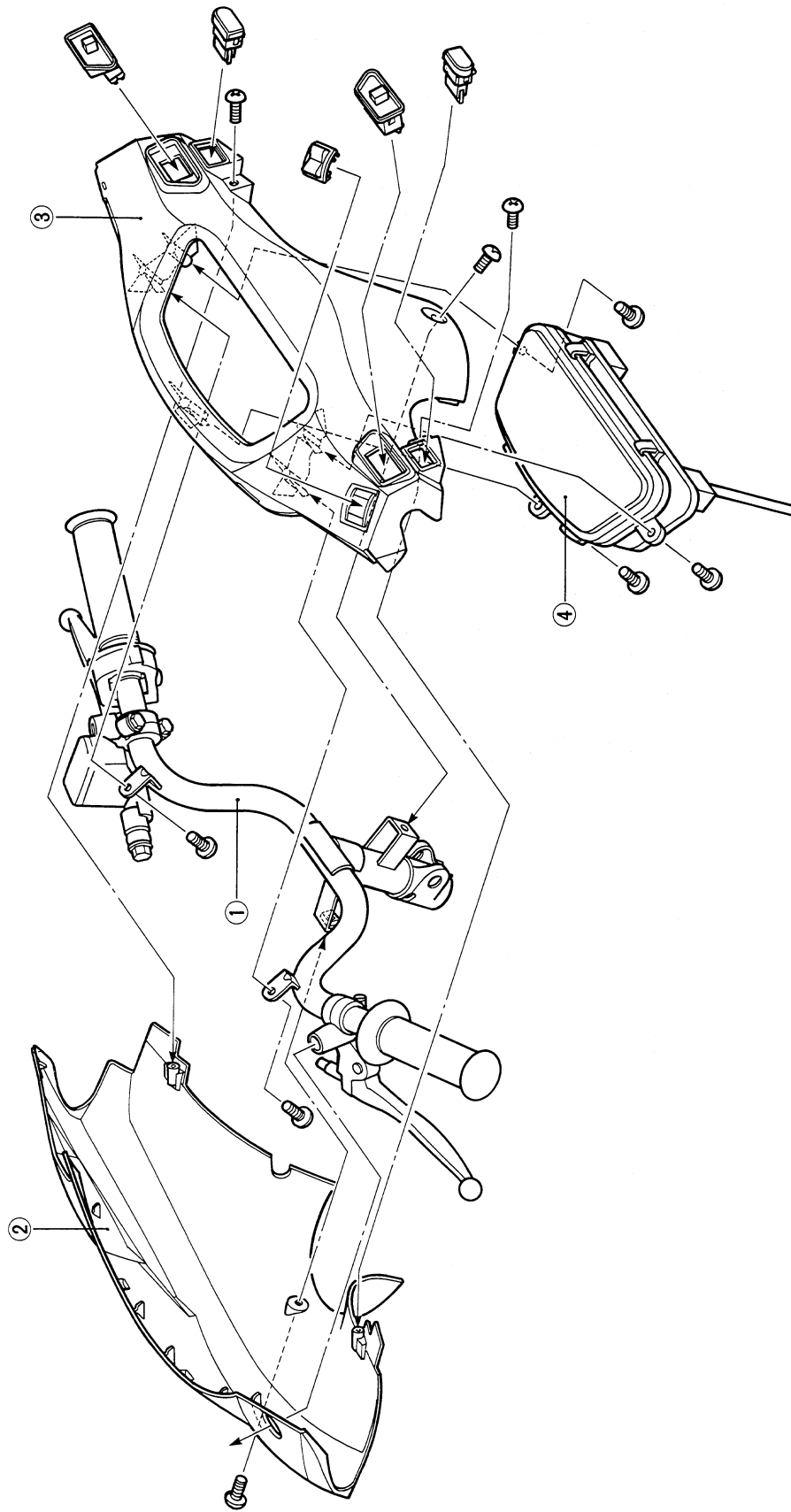

- ① Handlebars
- ② Front handlebar cover
- ③ Rear handlebar cover
- ④ Speedometer

REMOVAL

- Remove the leg shield cover. (Refer to page 5-2.)
- Remove the rear view mirrors ①.
- Remove the front handlebar cover by removing the its mounting screws (② and ③).
- Remove the rear handlebar cover by removing the its mounting screws (④ and ⑤), and disconnect the speedometer cable ⑥ and speedometer lead wires.

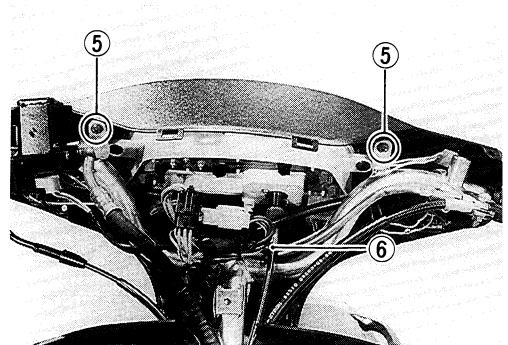
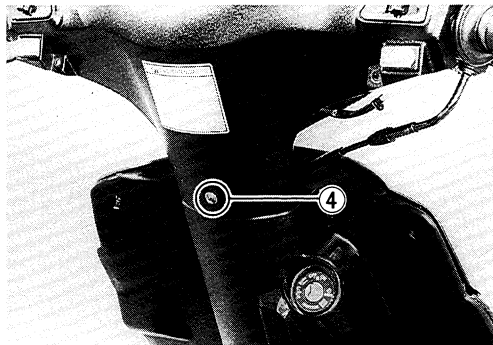
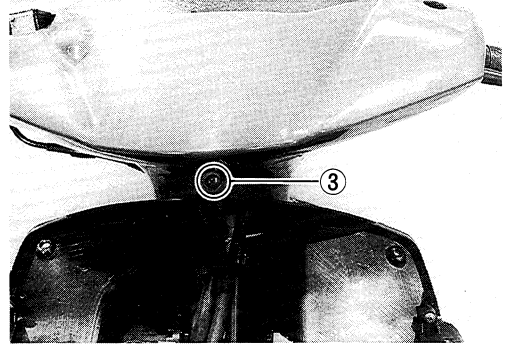
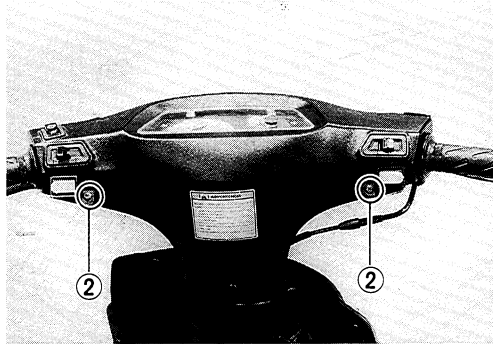
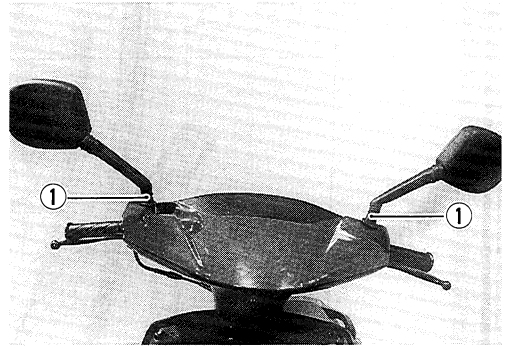

REMOUNTING

Remount the handlebar covers in the reverse order of removal.

STEERING STEM

- ① Handlebars
- ② Washer
- ③ Steering nut
- ④ Dust seal cover
- ⑤ Steering outer race (upper)
- ⑥ Steel ball
- ⑦ Steering inner race (upper)
- ⑧ Steering inner race (lower)
- ⑨ Steering outer race (lower)
- ⑩ Steering stem

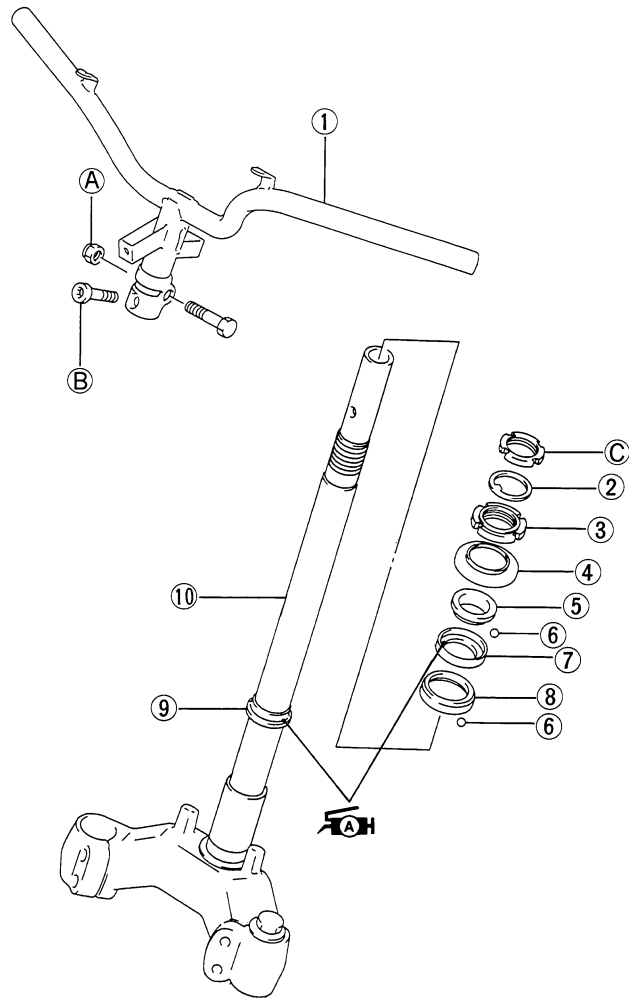

ITEM	N·m	kg-m	lb-ft
Ⓐ	49	4.9	35.5
Ⓑ	25	2.5	18.0
Ⓒ	80	8.0	58.0

REMOVAL AND DISASSEMBLY

- Remove the leg shield. (Refer to page 5-2.)
- Remove the front fork. (Refer to page 5-15.)
- Remove the handlebar cover. (Refer to page 5-21.)
- Remove the wire and cable clamp.

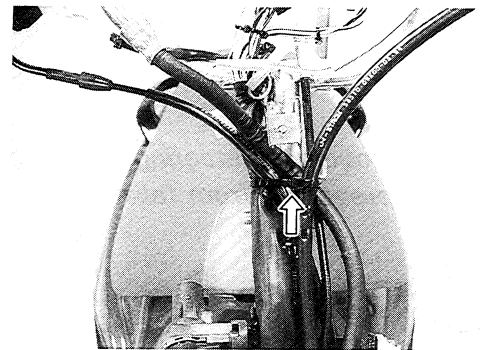

- Remove the throttle cable ① by removing the throttle grip case screws.
- Remove the brake master cylinder.

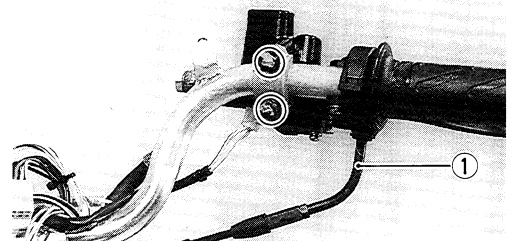

5-23 CHASSIS

- Remove the rear brake cable.

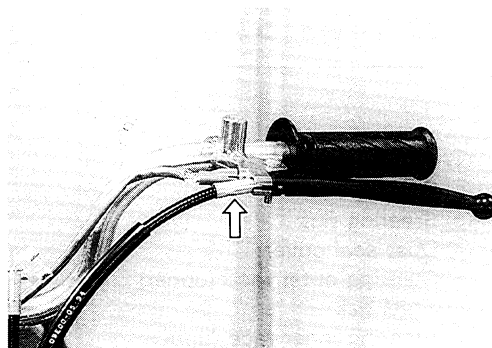

- Remove the handlebars by removing the clamp bolt ① and set bolt ②.

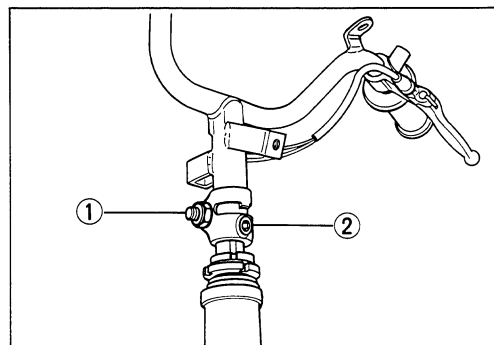

- Loosen the steering stem lock nut with the special tool.

 **09910-60611: Universal clamp wrench**

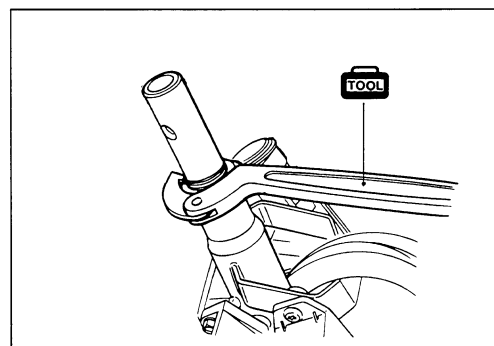

- Remove the washer ③.
- Remove the steering stem by removing the steering nut ④.

NOTE:

When removing the steering nut, hold the steering stem by hand to prevent it from falling.

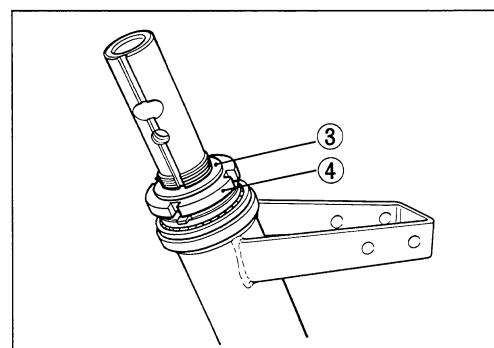

- Remove the lower bearing outer race with a chisel.

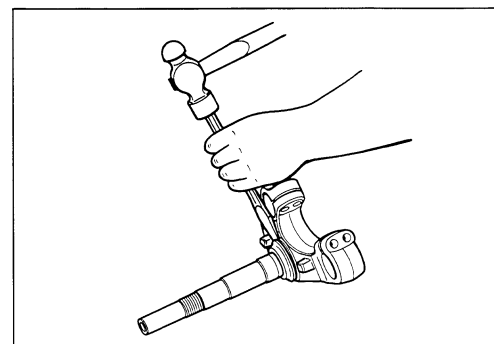

- Remove the upper and lower steel balls.

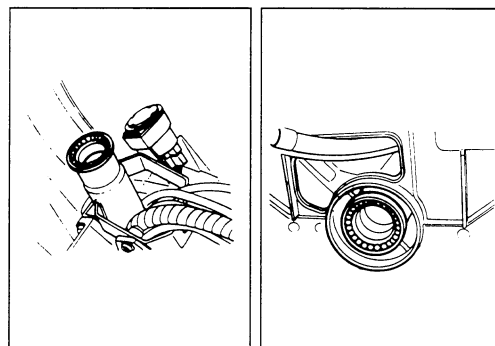

- Remove the upper and lower bearing inner races.

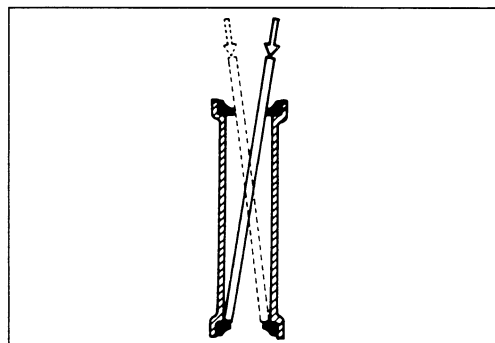

INSPECTION

Inspect and check the removed parts for the following abnormalities.

- * Bearing race wear and brinelling.
- * Worn and damaged steel balls.
- * Distortion of steering stem or handlebars.

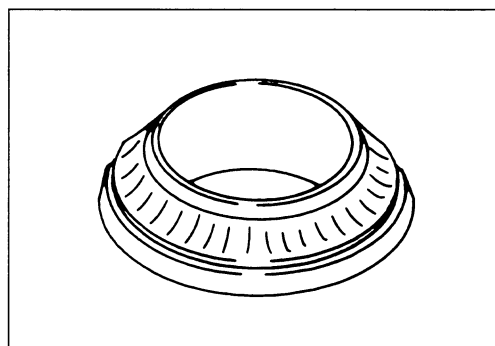

REASSEMBLY AND REMOUNTING

Reassemble and remount the steering stem and handlebars in the reverse order of removal and disassembly.

Pay attention to the following steps:

INNER RACES

- Press in the upper and lower inner races with the special tool.

 **09941-34513: Steering inner race installer**

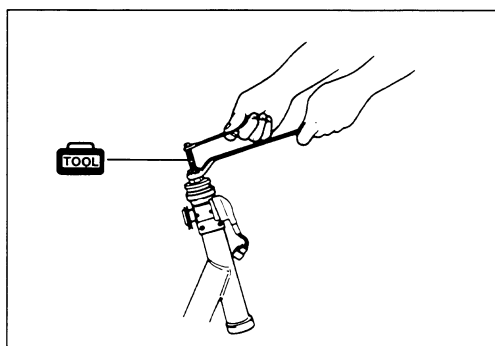

STEEL BALL

- Apply grease to the inner races when installing the upper and lower steel balls.

 **99000-25010: SUZUKI SUPER GREASE "A"**

Number of steel balls	Upper	22 pcs
	Lower	25 pcs

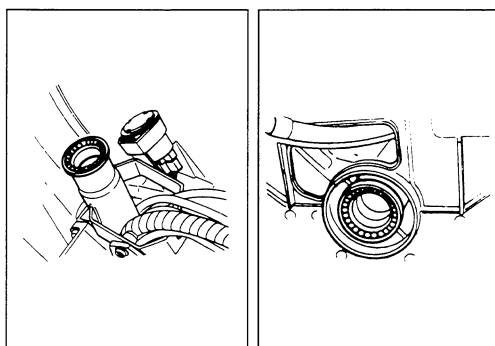

STEERING STEM NUT

- Tighten the steering stem nut, then loosen it 1/8—1/4 turn.

NOTE:

This adjustment will vary from motorcycle to motorcycle. Make sure that the steering turns smoothly and easily, left to right.

- When installing the washer, align the tongue ① of the washer with the groove ② of the steering stem shaft.

- Tighten the steering stem lock nut to the specified torque.

🔩 Steering stem lock nut: 80 N·m (8.0 kg-m, 58.0 lb-ft)

- Tighten the handlebars set bolt ③ and clamp nut ④ with your finger and then tighten them to the specified torque.

🔩 Set bolt ③ : 25 N·m (2.5 kg-m, 18.0 lb-ft)

Clamp nut ④ : 49 N·m (4.9 kg-m, 35.5 lb-ft)

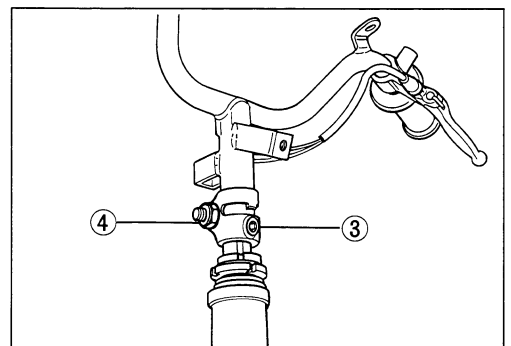
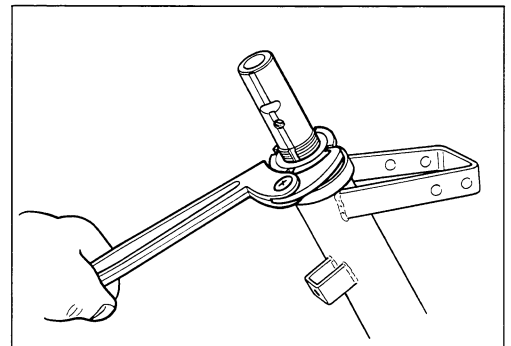
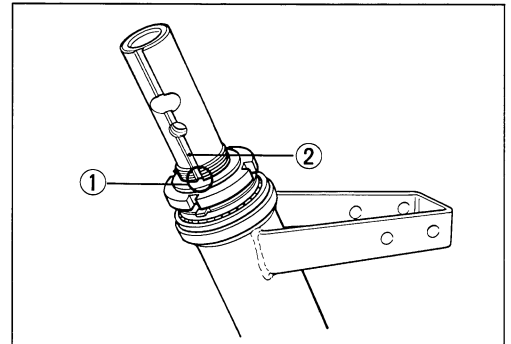
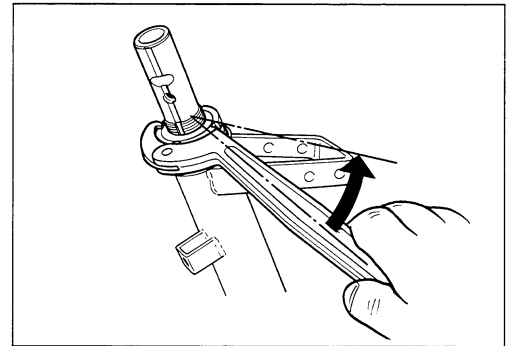

⚠ CAUTION

After performing the adjustment and installing the handlebars, "rock" the front wheel assembly forward and backward to ensure that there is no play and that the procedure was accomplished correctly. If play is noticeable, readjust the steering outer race nut.

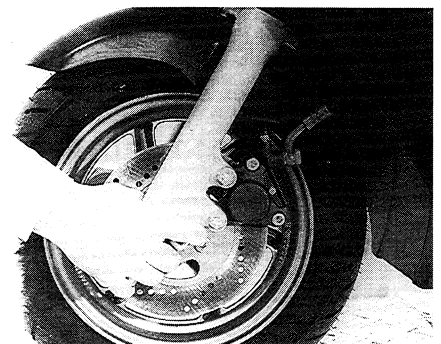

REAR WHEEL, BRAKE AND SHOCK ABSORBER

① Rear wheel
② Brake shoe
③ Brake camshaft
④ Brake cam lever

For the others

For Spain

U

ITEM	N·m	kg-m	lb-ft
Ⓐ	75	7.5	54.0
Ⓑ	7	0.7	5.0
Ⓒ	29	2.9	21.0
Ⓓ	32	3.2	23.0

REMOVAL AND DISASSEMBLY

REAR WHEEL AND BRAKE

- Place the motorcycle on level ground.
- Remove the muffler. (Refer to page 3-5.)
- Remove the rear wheel.

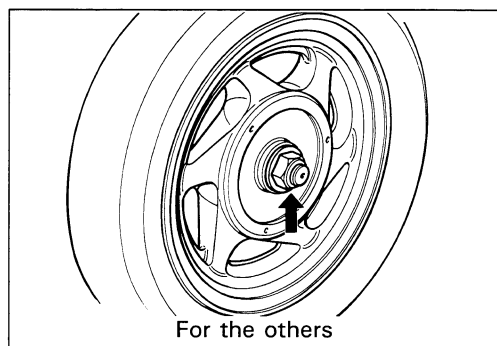
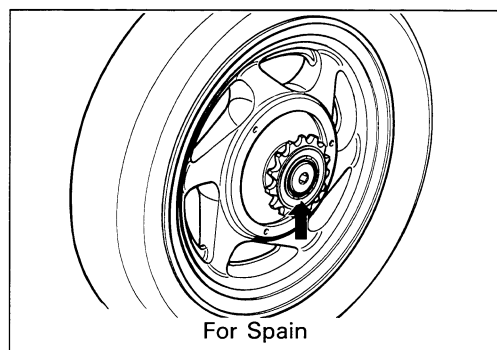

- Remove the brake shoes.

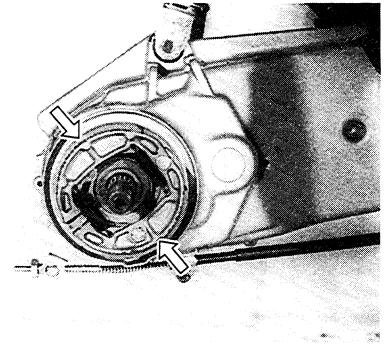

REAR SHOCK ABSORBER

- Remove the frame cover. (Refer to page 5-3.)
- Remove the rear shock absorber.

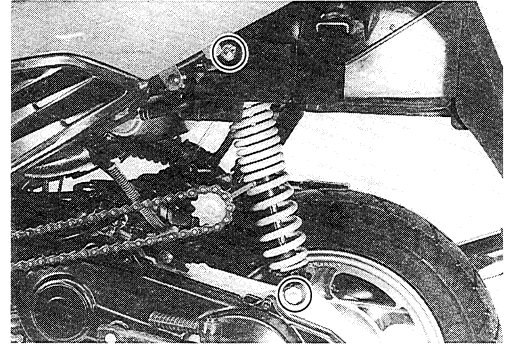

INSPECTION

BRAKE DRUM

Measure the brake drum I.D. to determine the extent of wear and, if the limit is exceeded by the wear noted, replace the drum. The value of this limit is indicated inside the drum.

Service Limit: 120.7 mm (4.75 in)

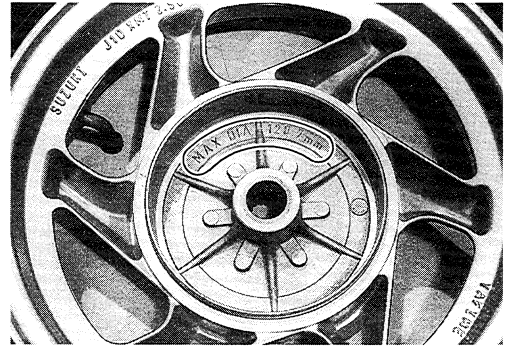

TIRE

Refer to page 2-10.

BRAKE SHOE

Check the brake shoe and decide whether it should be replaced or not from the thickness of the brake shoe lining.

Service Limit: 1.5 mm (0.06 in)

▲ CAUTION

Replace the brake shoe with a set, otherwise braking performance will be adversely affected.

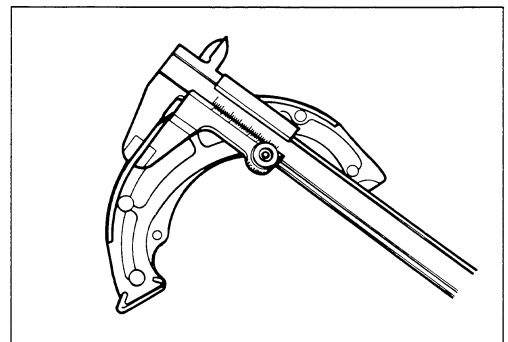

REAR SHOCK ABSORBER

Inspect the shock absorber for oil leakage or other damage.

⚠ CAUTION

Do not attempt to disassemble the shock absorber. It is not serviceable.

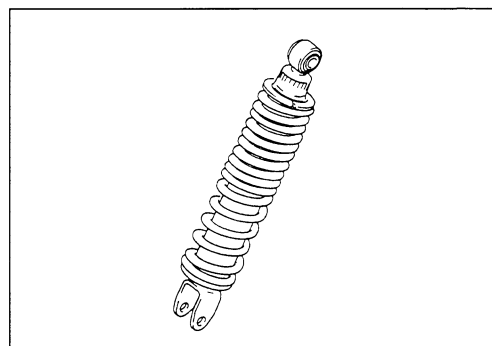
**REASSEMBLY AND REMOUNTING**

Reassemble and remount the rear wheel, brake and shock absorber in the reverse order of removal and disassembly.

- Tighten the rear axle nut to the specified torque.

🔩 Rear axle nut: 75 N·m (7.5 kg-m, 54.0 lb-ft)

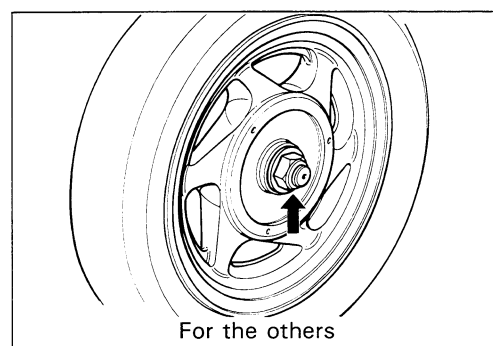
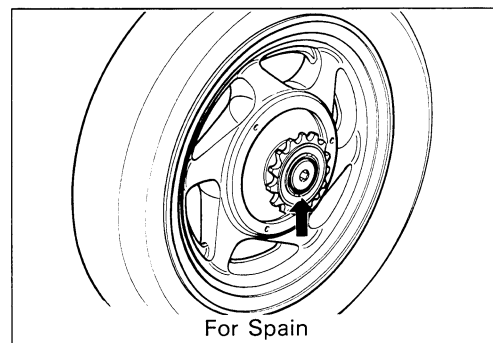

- Tighten the rear shock absorber bolt and nut to the specified torque.

🔩 Bolt (Upper) ①: 29 N·m (2.9 kg-m, 21.0 lb-ft)
Nut ② : 32 N·m (3.2 kg-m, 23.0 lb-ft)

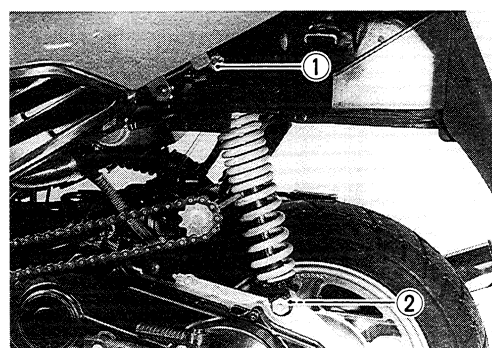

ELECTRICAL SYSTEM

CONTENTS

<i>CAUTIONS IN SERVICING</i>	6- 1
<i>LOCATION OF ELECTRICAL COMPONENTS</i>	6- 3
<i>CHARGING AND LIGHTING SYSTEM</i>	6- 4
<i>STARTER SYSTEM</i>	6- 7
<i>IGNITION SYSTEM</i>	6-11
<i>SPEEDOMETER</i>	6-13
<i>FUEL METER AND GAUGE</i>	6-14
<i>OIL LEVEL SWITCH</i>	6-15
<i>THERMOELEMENT</i>	6-15
<i>SWITCHES</i>	6-16
<i>BATTERY</i>	6-17

CAUTIONS IN SERVICING

CONNECTOR

- When connecting a connector, be sure to push it in until a click is felt.
- Inspect the connector for corrosion, contamination and breakage in its cover.

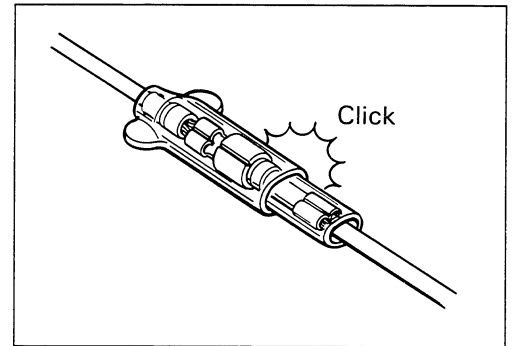

COUPLER

- With a lock type coupler, be sure to release the lock before disconnecting it and push it in fully till the lock works when connecting it.
- When disconnecting the coupler, be sure to hold the coupler itself and do not pull the lead wires.
- Inspect each terminal on the coupler for being loose or bent.
- Inspect each terminal for corrosion and contamination.

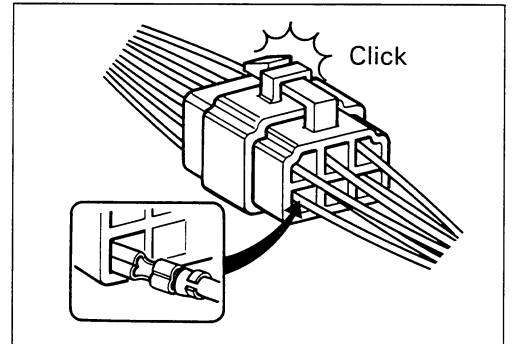

CLAMP

- Clamp the wire harness at such positions as indicated in "WIRE HARNESS ROUTING" (Refer to page 7-11.).
- Bend the clamp properly so that the wire harness is clamped securely.
- In clamping the wire harness, use care not to allow it to hang down.
- Do not use wire or any other substitute for the band type clamp.

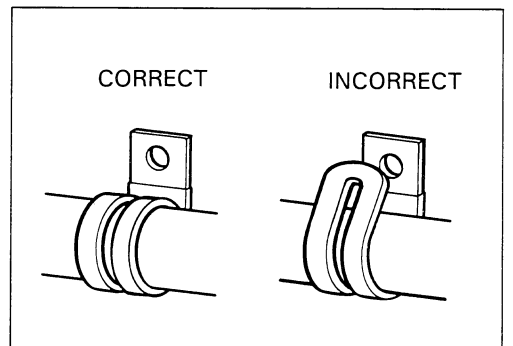

FUSE

- When a fuse blows, always investigate the cause, correct it and then replace the fuse.
- Do not use a fuse of a different capacity.
- Do not use wire or any other substitute for the fuse.

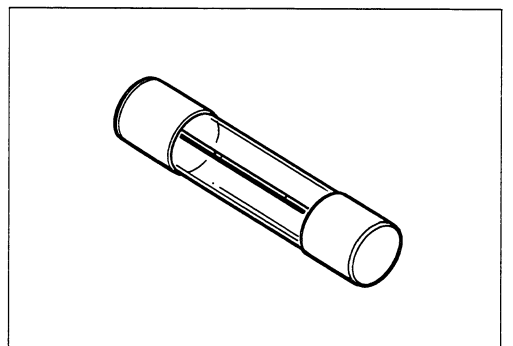

BATTERY

Except for Spain model

- The MF battery used in this vehicle does not require maintenance as inspection of electrolyte level and replenishment of water.
- No hydrogen gas is produced during normal charging of the battery, but such gas may be produced when it is overcharged. Therefore, do not bring fire near the battery while it is being charged.
- Note that the charging system for the MF battery is different from that of an ordinary battery. Do not replace with an ordinary battery.

CONNECTING BATTERY

- When disconnecting terminals from the battery for disassembly or servicing, be sure to disconnect the negative (\ominus) terminal first.
- When connecting terminals to the battery, be sure to connect the positive (\oplus) terminal first.
- If the terminal is found corroded, remove the battery, pour warm water over it and clean with a wire brush.
- Upon completion of connection, apply grease lightly.
- Put a cover over the positive (\oplus) terminal.

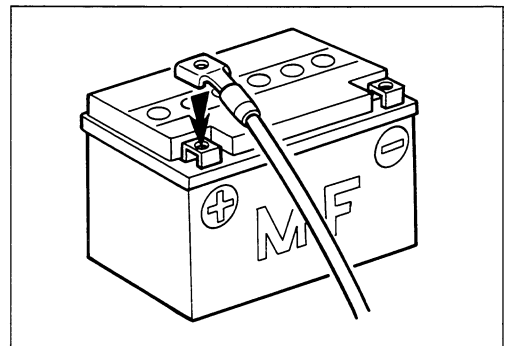
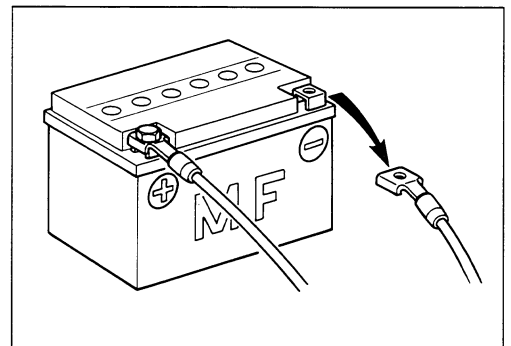
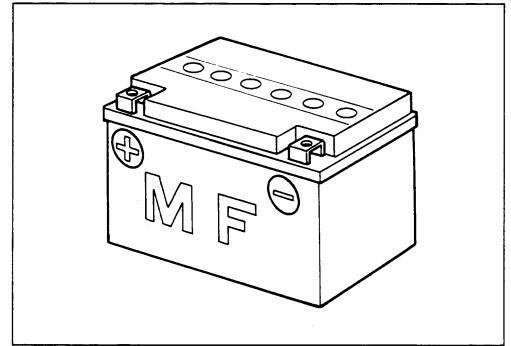

WIRING PROCEDURE

- Route the wire harness properly according to "WIRE HARNESS ROUTING" (Refer to page 7-11).

USING POCKET TESTER

- Be sure to use positive (\oplus) and negative (\ominus) probes of the tester properly. Their false use may cause damage in the tester.
- If the voltage and current values are not known, start measuring in the higher range.
- Before measuring the resistance and after changing the resistance range, always perform 0 Ω adjustment.
- Taking a measurement where voltage is applied in the resistance range may cause damage in the tester. When measuring resistance, check to make sure that no voltage is applied there.
- After using the tester, turn the switch to the OFF position.

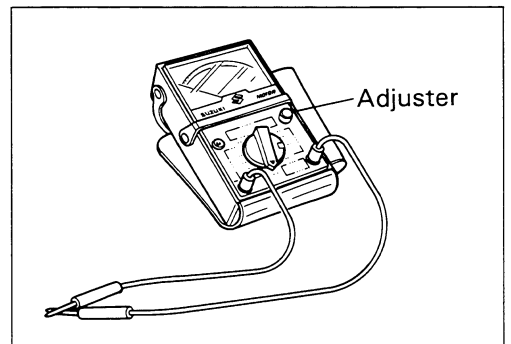

LOCATION OF ELECTRICAL COMPONENTS

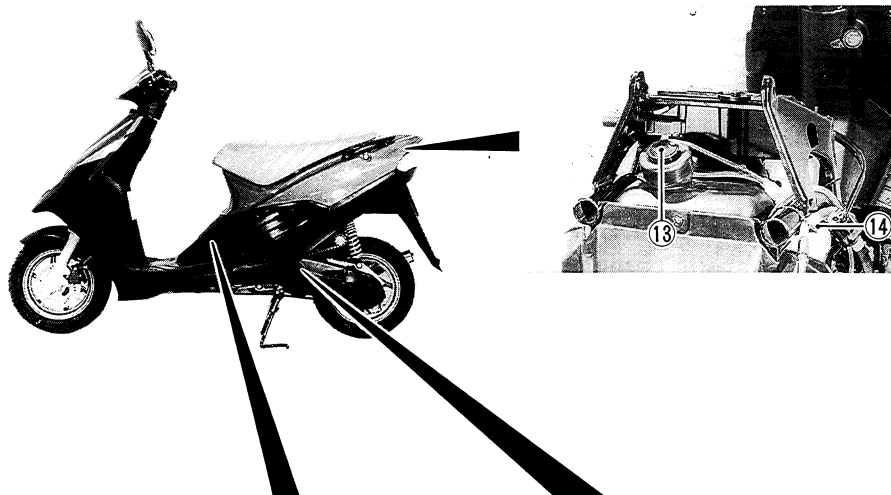
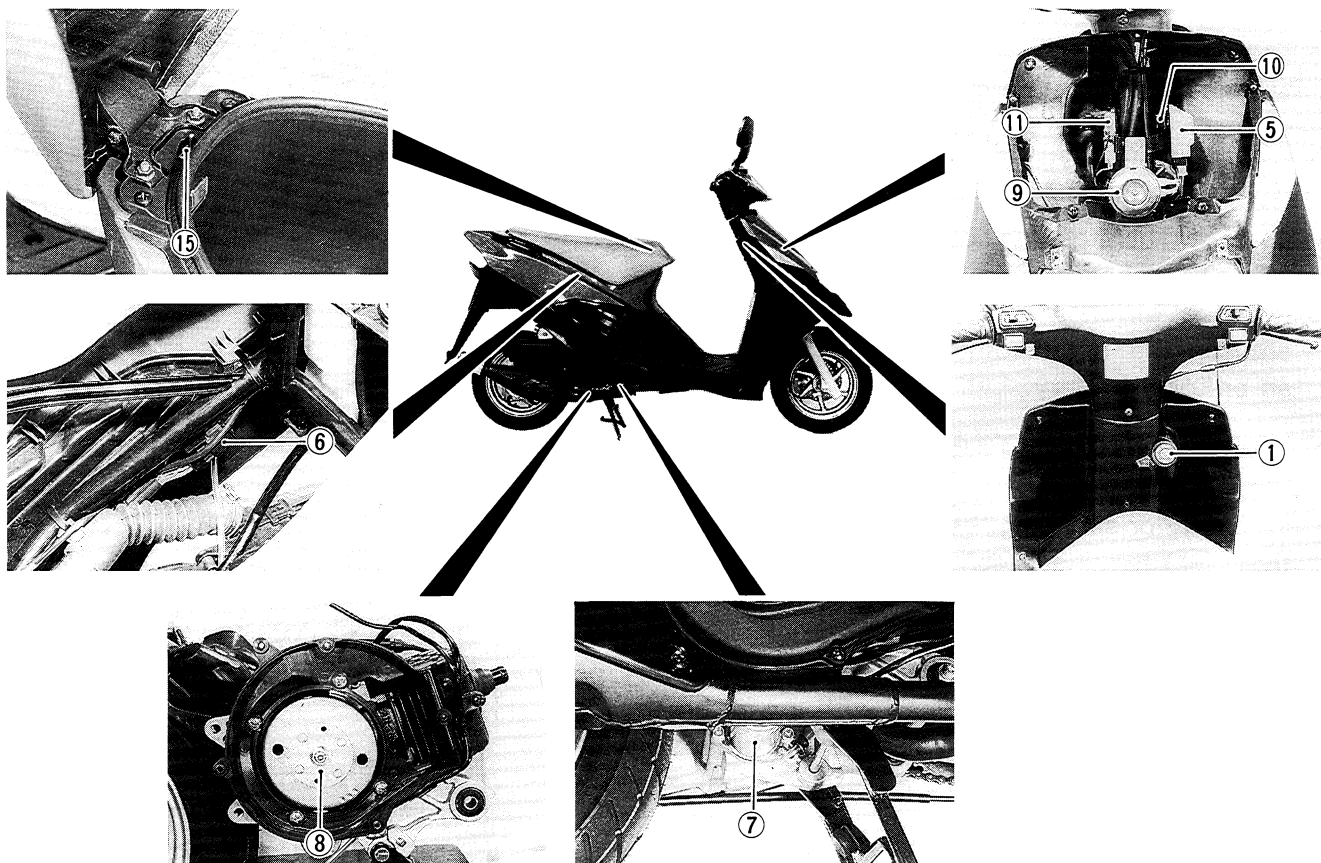

- ① : Ignition switch
- ② : CDI/Ignition coil
- ③ : Battery
- ④ : Fuse
- ⑤ : Regulator/Rectifier
- ⑥ : Starter relay
- ⑦ : Starter motor
- ⑧ : Magneto
- ⑨ : Horn
- ⑩ : Turn signal relay
- ⑪ : Resistor
- ⑫ : Thermoelement
- ⑬ : Fuel gauge
- ⑭ : Oil level indicator switch
- ⑮ : Trunk light switch

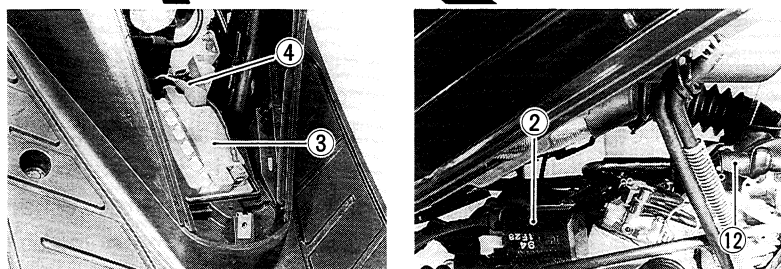

CHARGING AND LIGHTING SYSTEM

The charging system uses the flywheel magneto as shown in the figure. The charging and lighting coils are mounted on the magneto stator and generate AC as the flywheel rotor turns. AC generated in the charging coil flows to the regulator/rectifier which changes AC to DC. This DC then charges the battery. On the other hand, lighting coil supplies AC current to the headlight, taillight, and meter light under the regulated condition.

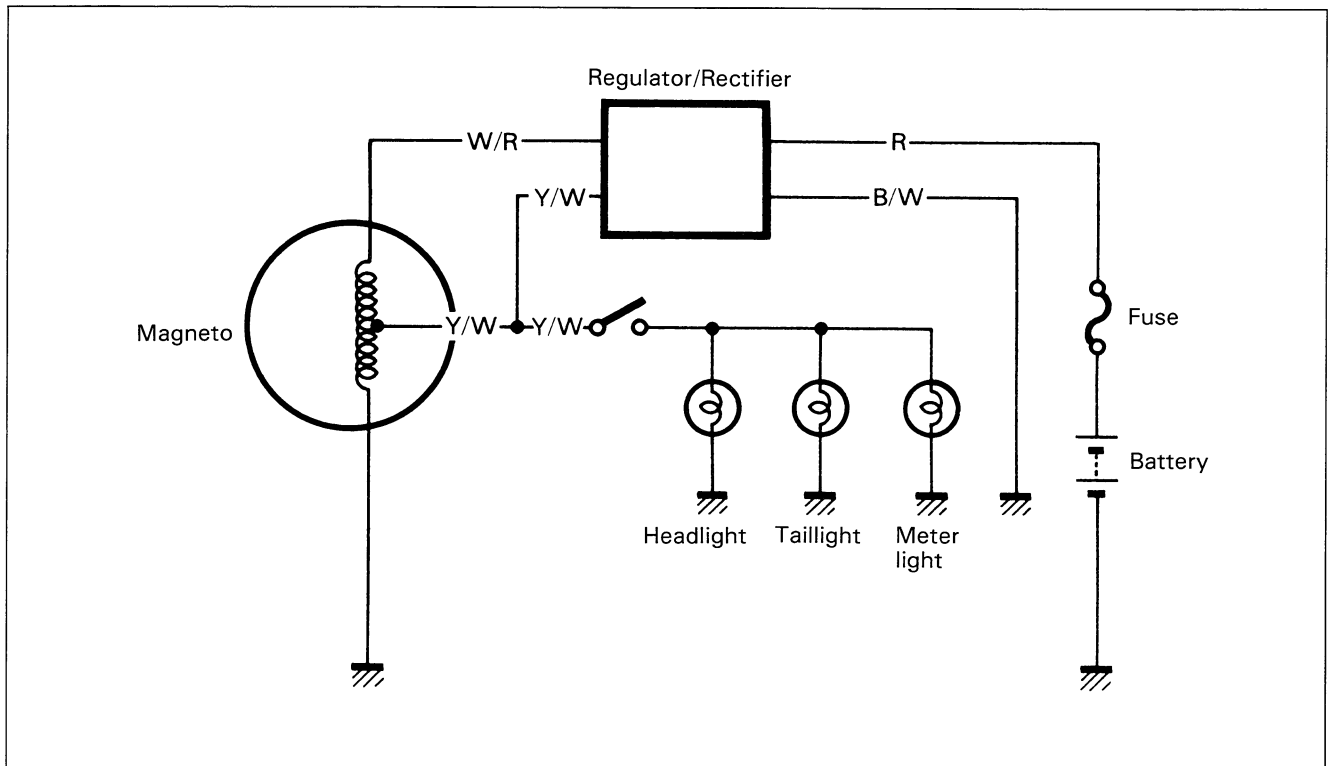

TROUBLESHOOTING

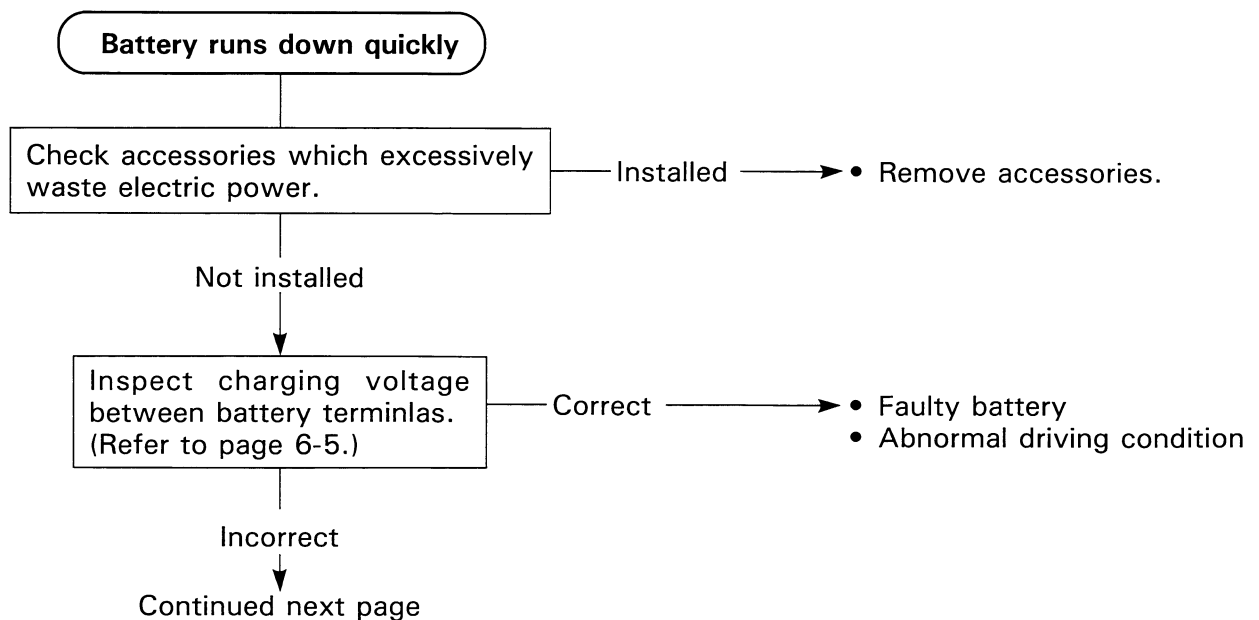

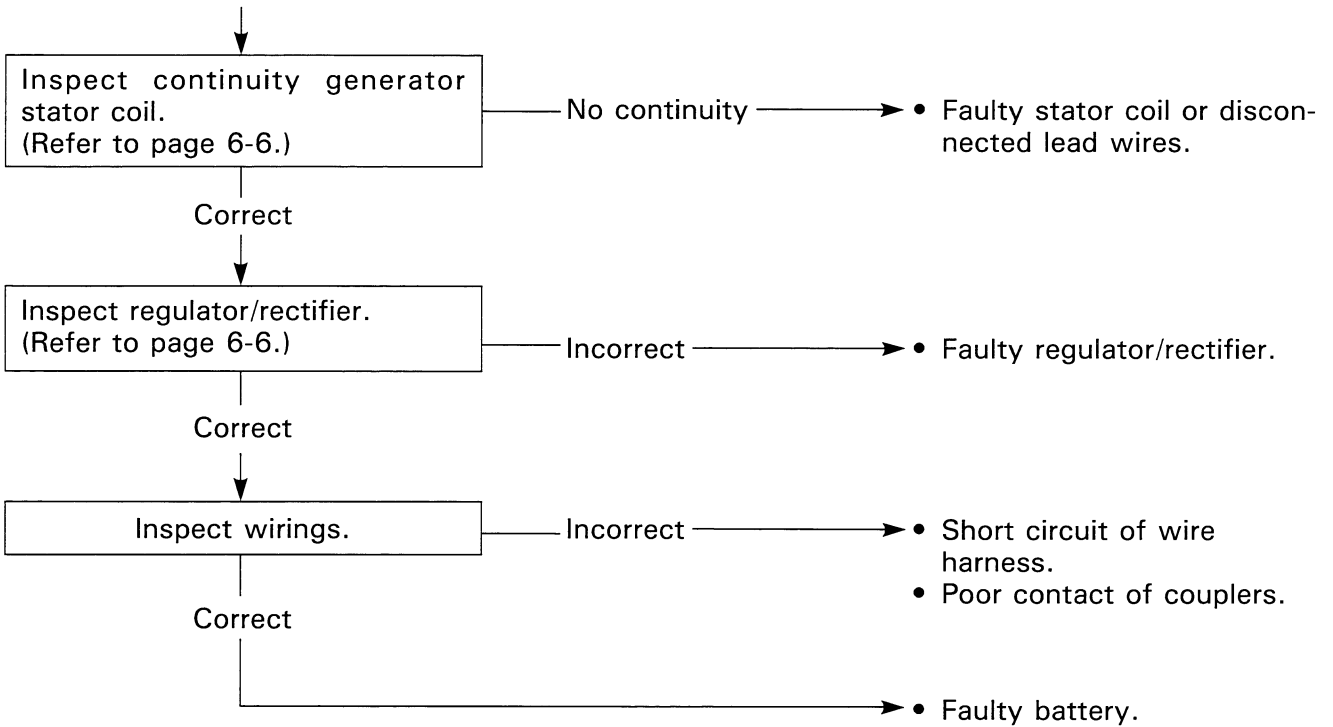

Others

Battery overcharge	<ul style="list-style-type: none"> • Faulty regulator/rectifier • Faulty battery • Poor contact of regulator/rectifier lead wire coupler
--------------------	---

INSPECTION

CHARGING OUTPUT CHECK

Start the engine and keep it running at 5 000 r/min with lighting switch turned ON.

Measure the DC voltage between the battery terminal ⊕ and ⊖ with a pocket tester.

If the tester reads under or over following specification, check the no-load performance or replace the regulator/rectifier.

NOTE:

When making this test, be sure that the battery is in fully-charged condition.

- 09900-25002: Pocket tester**
- 09900-26006: Tachometer**

STD charging output: 13.0—15.0V at 5 000 r/min.

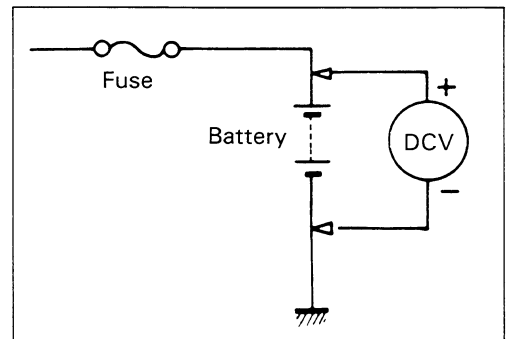
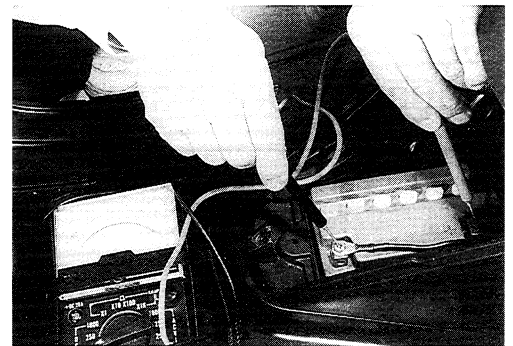

NO-LOAD PERFORMANCE

- Disconnect the magneto lead wire coupler.
- Start the engine and keep it running at 5 000 r/min.
- Using a pocket tester, measure the AC voltage between the White with Red tracer lead wire and ground. If the tester reading is as follows, magneto is in good condition.

 **STD No-load performance: More than 25V (AC) at 5 000 r/min.**

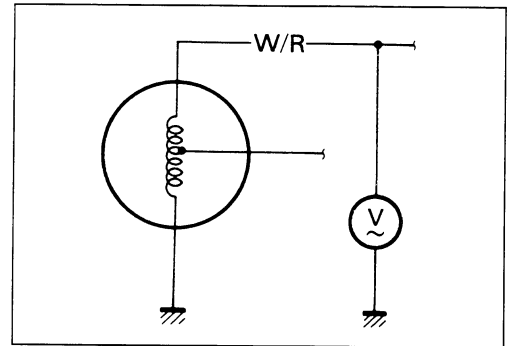

STATOR COILS

Using a pocket tester, measure the resistance between the lead wire and ground.

If the resistance checked is incorrect, replace the coil.

 **09900-25002: Pocket tester**

 **Tester knob indication: × 1 Ω range**

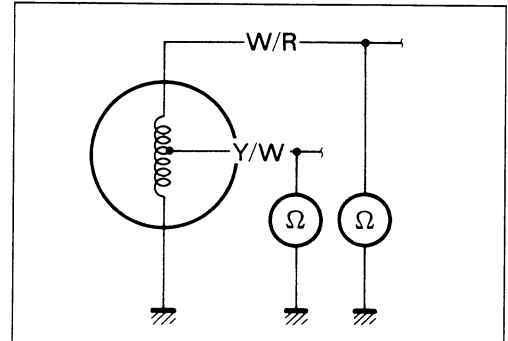

	Standard resistance
W/R—Ground	0.5—1.2 Ω
Y/W—Ground	0.3—1.0 Ω

REGULATOR/RECTIFIER

- Disconnect the coupler.
- Using the pocket tester (× 1 kΩ range), measure the resistance between the terminals as shown in the following table. If the resistance checked is incorrect, replace the regulator/rectifier.

 **09900-25002: Pocket tester**

 **Tester knob indication: × 1 kΩ range**

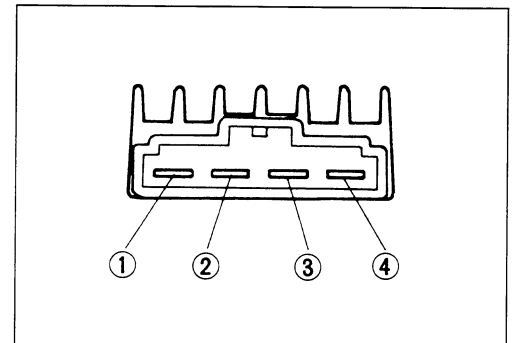

Unit: kΩ

		⊕ Probe of tester to:			
		①	②	③	④
⊖ Probe of tester to:	①		10—100	∞	∞
	②	10—100		∞	∞
	③	∞	∞		5—30
	④	∞	∞	∞	

STARTER SYSTEM

DESCRIPTION

The starter system is shown in the diagram below: namely, the starter motor, relay, starter switch and battery. Depressing the starter button (on the right handlebar switch box) while squeezing the front or rear brake lever energizes the relay, causing the contact points to close which connects the starter motor to the battery.

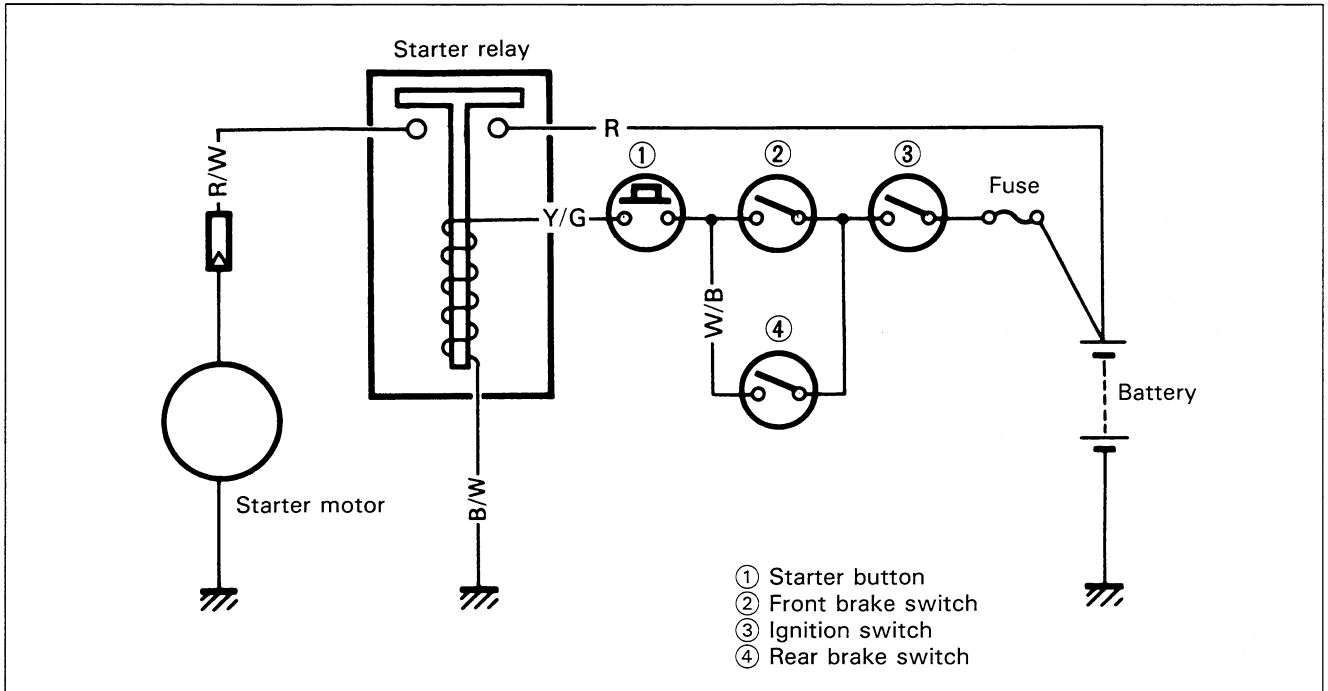

TROUBLESHOOTING

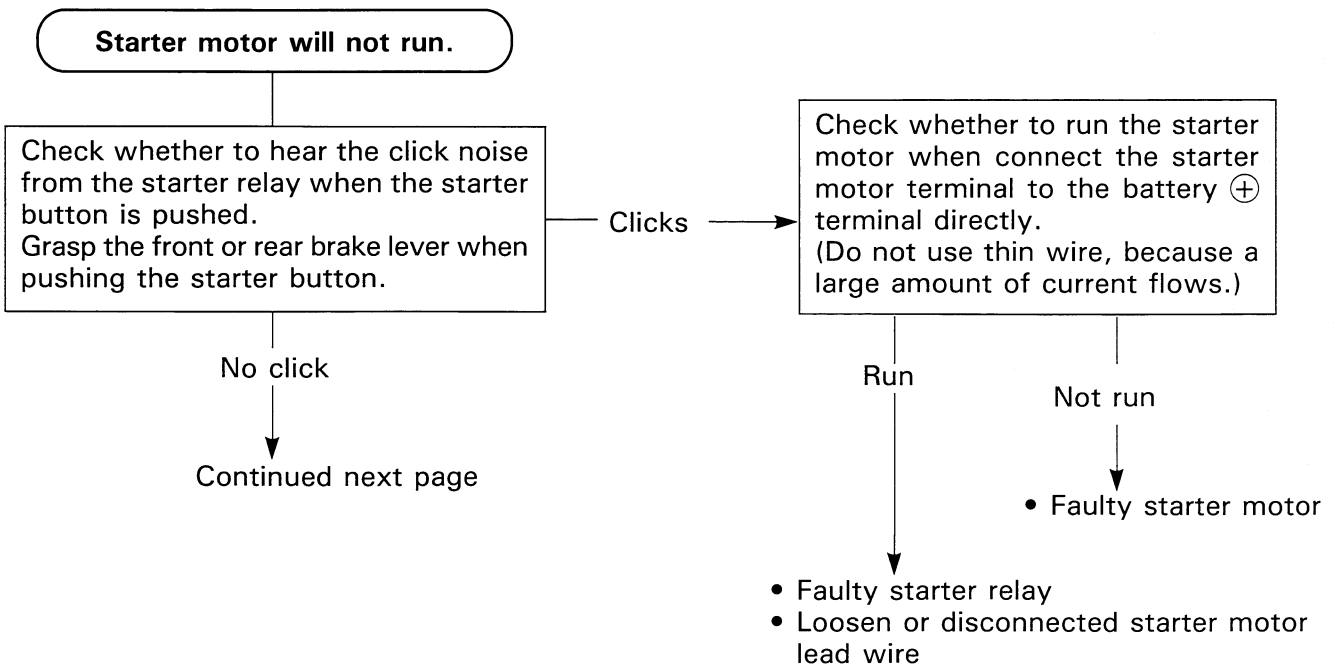

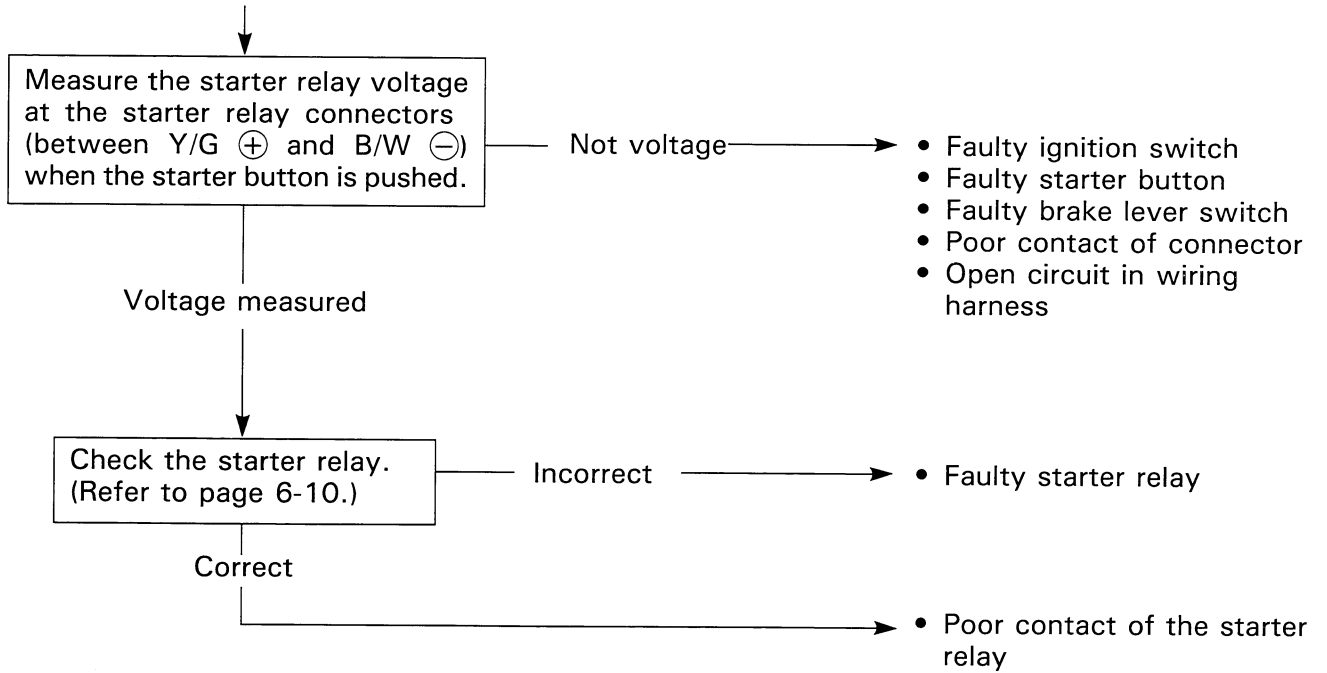

Others

<p>Engine does not turn though starter motor runs.</p>	<ul style="list-style-type: none"> • Faulty starter pinion
--	---

STARTER MOTOR REMOVAL AND DISASSEMBLY

- Remove the muffler.
- Remove the starter motor. (Refer to page 3-8.)

- Disassemble the starter motor as shown in the illustration.

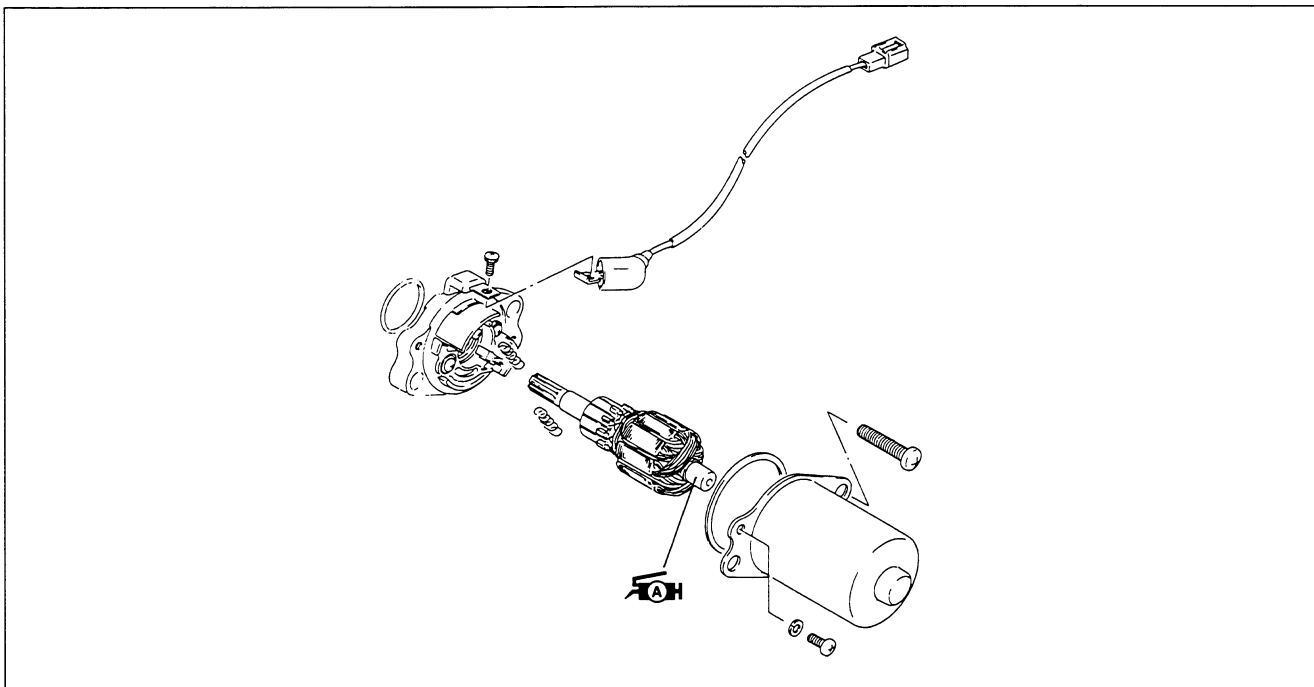

STARTER MOTOR INSPECTION

CARBON BRUSHES

Inspect the brushes for damage or wear. If any damage is found, replace them.

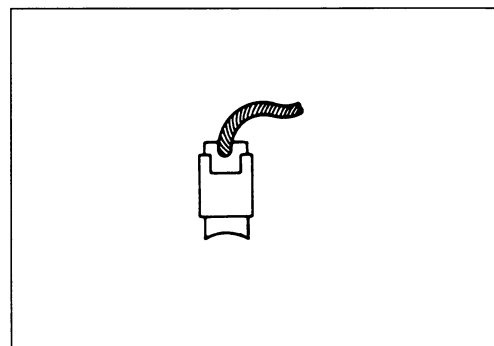

COMMUTATOR

If the commutator surface is dirty, starting performance will decrease. Polish the commutator with # 400 or similar fine emery paper when it is dirty. After polishing wipe the commutator with a clean dry cloth.

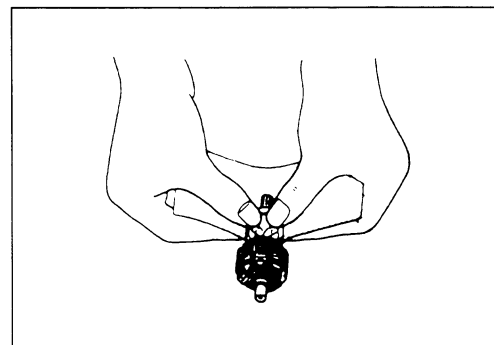

ARMATURE COIL

Using the pocket tester, check the coil for open and ground by placing probe pins on each commutator segment and rotor core (to test for ground) and on any two segments at various places (to test for open), with the brushes lifted off the commutator surface.

If the coil is found to be open-circuited or grounded, replace the armature. Continuous use of a defective armature will cause the starter motor to suddenly fail.

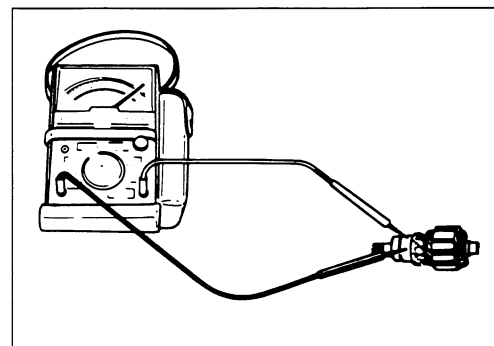

STARTER RELAY INSPECTION

Disconnect lead wire (R/W) of the starter motor.

Turn on the ignition switch and squeeze the front or rear brake lever, then inspect the continuity between the Red and Red/White lead wires at the starter relay when pushing the starter button.

If the starter relay is in sound condition, continuity is found.

 **09900-25002: Pocket tester**

Check the coil for “open”, “ground” and ohmic resistance. The coil is in good condition if the resistance is as follows.

 **09900-25002: Pocket tester**

STD resistance: 50—90 Ω

 **Tester knob indication: $\times 10 \Omega$ range**

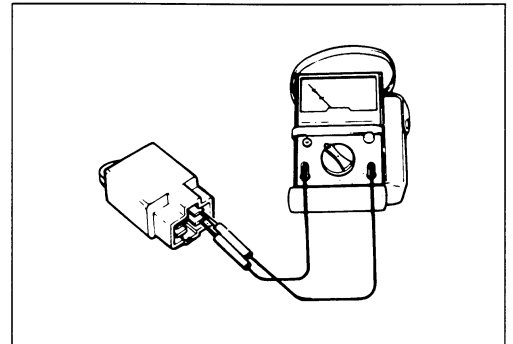

IGNITION SYSTEM

The ignition system consists of a flywheel magneto, a CDI & ignition coil unit and a spark plug.

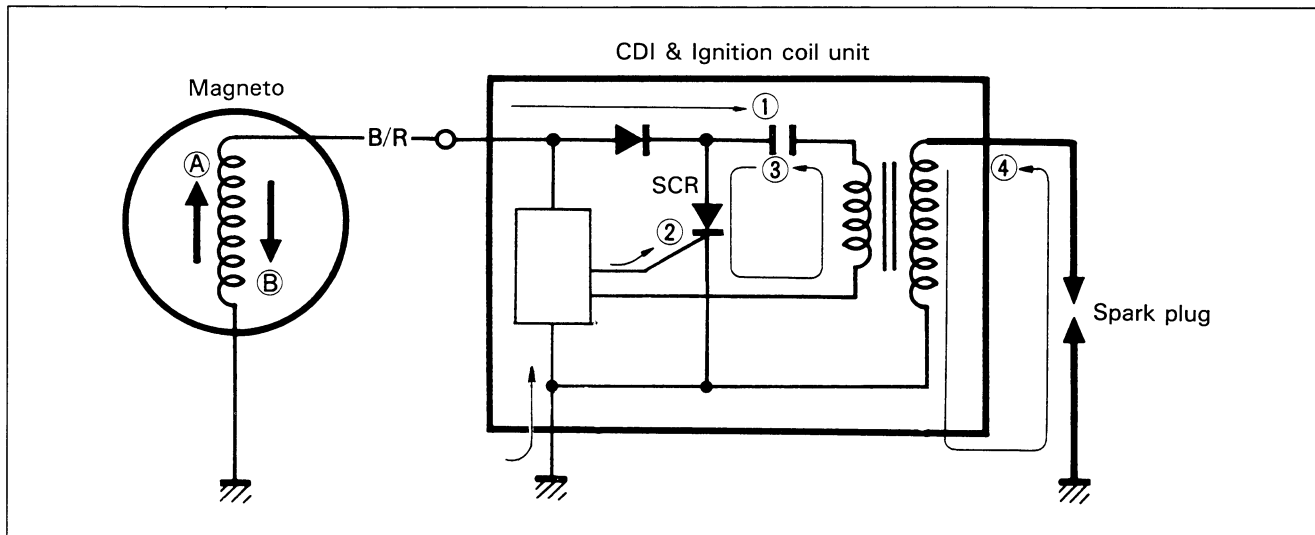

- ① As the rotor rotates, an AC current is induced in the coil. The current induced in the (A) direction charges up the capacitor.
 - ② As the rotor rotates further, the current is induced in the reverse direction (B) direction). This current causes a voltage applied through the ground to the gate of SCR.
 - ③ As the SCR conducts, the energy which has been charged in the capacitor is instantaneously discharged through the primary winding of the ignition coil.
 - ④ The current which flows in the primary winding of the ignition coil causes a high voltage induced in the secondary winding of the ignition coil. The induced voltage is much higher than the voltage of the primary winding because it is boosted up by the high ratio of turns between primary and secondary windings.
- The high voltage is fed to the spark plug, where it produces discharge sparks across the spark plug gap and sparks ignite the fuel/air mixture in the combustion chamber.

TROUBLE SHOOTING

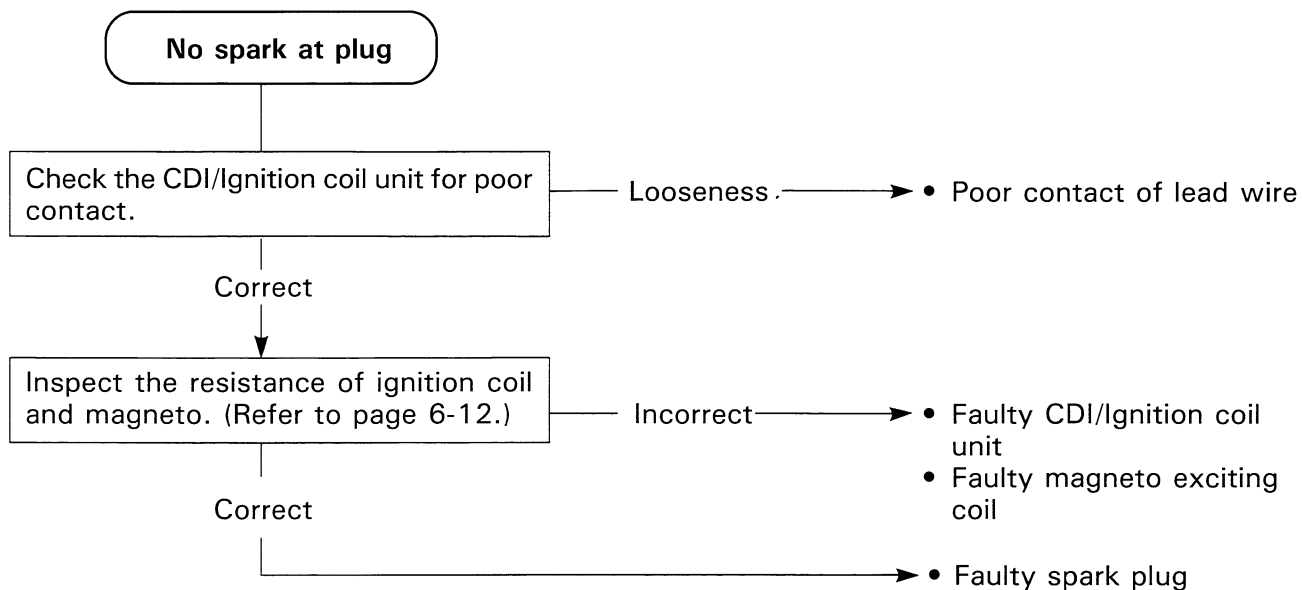

CDI UNIT AND IGNITION COIL INSPECTION

CHECKING WITH ELECTRO TESTER

Connect the ignition coil test lead to the ignition coil terminals. Connect the high tension leads, red \oplus lead to the spark plug cord and the black \ominus lead to the terminal of the ignition coil test lead.

- Set the test selector knob to "P.E.I."
- Connect the power lead to the appropriate AC source.
- Switch the power ON.
- Note the spark in the spark gap window. It should be strong and continuous, not intermittent, across a preset 8 mm gap. Allow the spark to jump the test gap for at least five minutes continuously, to insure proper operation under the temperature of actual riding.

TOOL 09900-28106: Electro tester
09930-81010: Ignition coil test lead

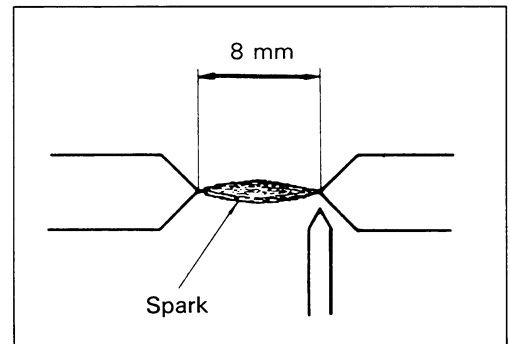
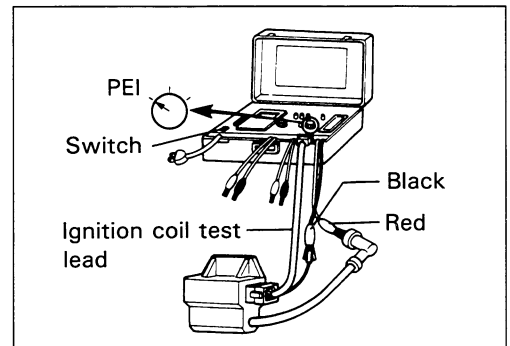

CHECKING WITH SUZUKI POCKET TESTER

Use a pocket tester, provided that it has a "x 1k ohm" range. Inspect the resistance between plug cap and ground terminal of the ignition coil.

TOOL 09900-25002: Pocket tester

Ignition coil secondary

resistance: 14–30 k Ω (Plug cap—Terminal of B/W lead wire side)

TESTER Tester knob indication: $\times 1\text{k}\Omega$ range

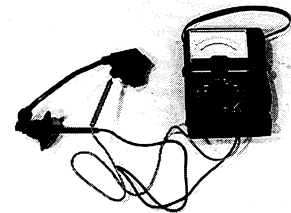

CAUTION

As the diode, condenser and SCR are provided in the primary circuit, the primary circuit cannot be checked by using an ohmmeter.

MAGNETO EXCITING COIL

- Remove the right frame lower side cover. (Refer to page 5-2.)
- Disconnect the exciting coil lead wire (Black with Red tracer).
- Using a pocket tester, measure the resistance between the B/R lead wire and ground.
If the resistance checked is incorrect, replace the coil.

TOOL 09900-25002: Pocket tester

Exciting coil resistance: 170–270 Ω

TESTER Tester knob indication: $\times 100 \Omega$ range

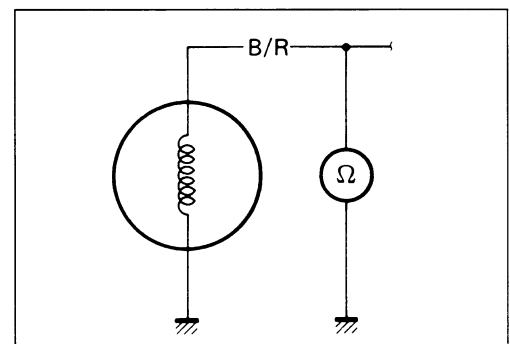

SPEEDOMETER

Disassemble the speedometer as shown in the illustration.

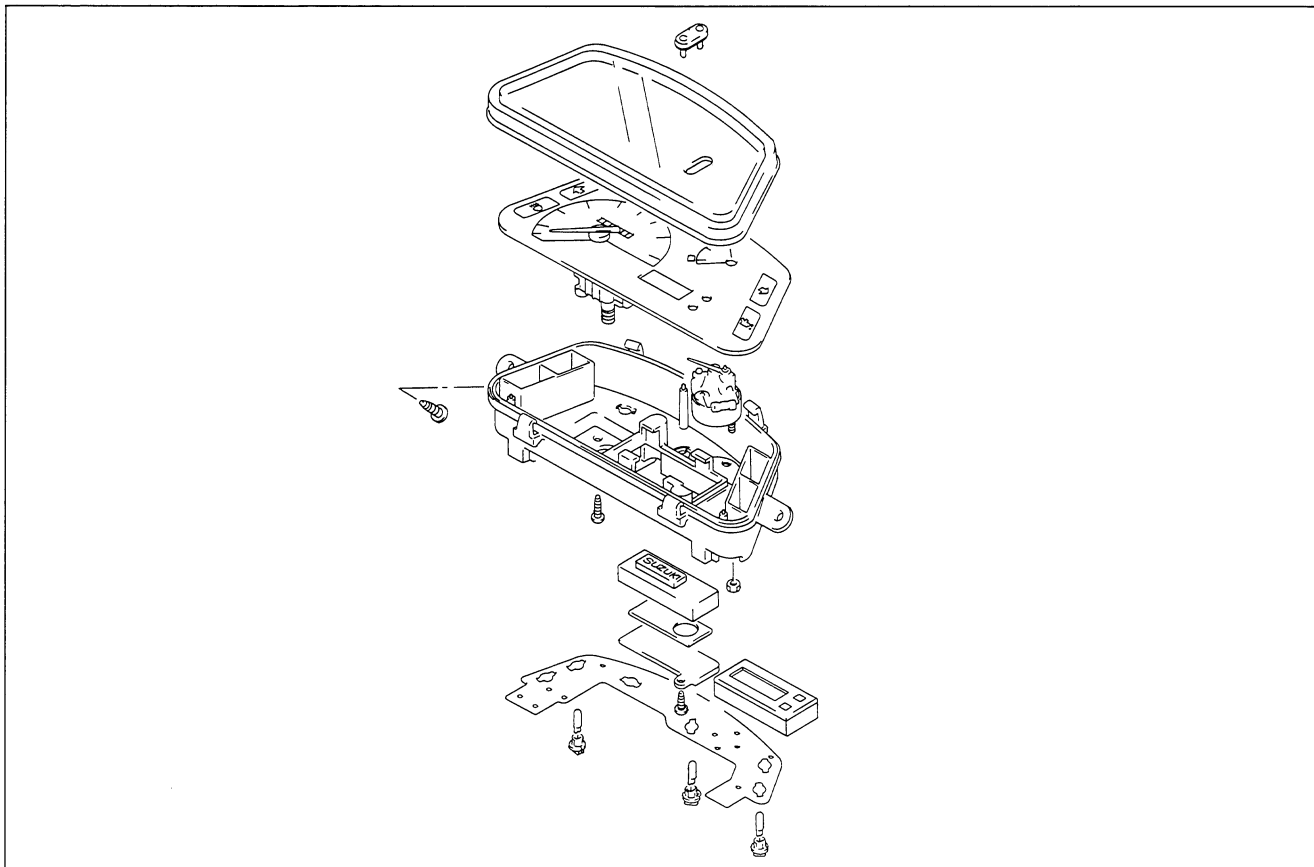

INSPECTION

Using a pocket tester, check the bulb continuity.
If the continuity is incorrect, replace the bulb.

 09900-25002: Pocket tester

FUEL METER AND GAUGE

FUEL METER INSPECTION

To test the Fuel Meter two different checks may be used. The first, and simplest test will tell if the meter is operating but will not indicate the meters accuracy throughout the range. To perform this test, lift the seat and remove the frame cover (refer to page 5-4), then disconnect the B/W and Y/B lead wire coupler of the fuel gauge sending unit. Connect a jumper wire between B/W and Y/B wires coming from the main wiring harness. With the ignition switch turned ON, the fuel meter should indicate "F".

The second test will check the accuracy of the meter in the full and empty positions. Connect a 90-ohm resistor between the Y/B and B/W lead wires. The fuel meter is normal if its pointer indicates the E (empty) position when the specified voltage is applied to the circuit and if its pointer indicates the F (full) position when the resistor is changed to 10 ohms. If either one or both indications are abnormal, replace the fuel meter with a new one.

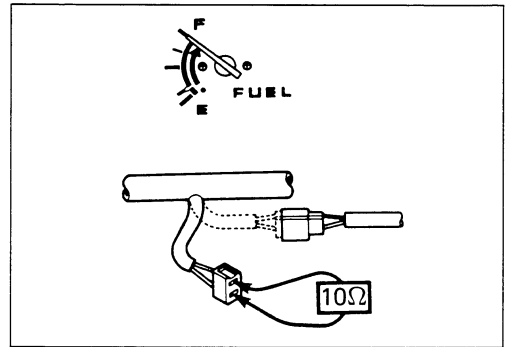
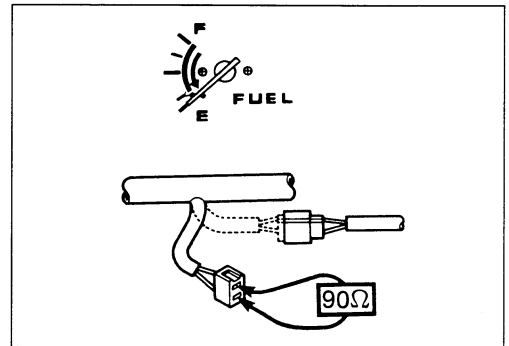
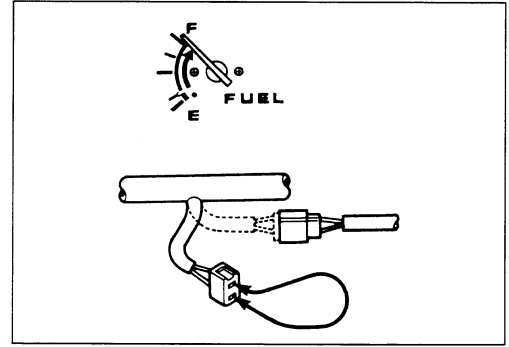

FUEL GAUGE INSPECTION

- Disconnect the lead wires coming out of the fuel gauge and check resistance of each position.
- If the resistance measured is incorrect, replace the fuel gauge assembly with a new one.
- The relation between the position of the fuel gauge float and resistance is shown in the following table.

Float position	Resistance
F (Full)	Approx. 10 Ω
E (Empty)	Approx. 90 Ω

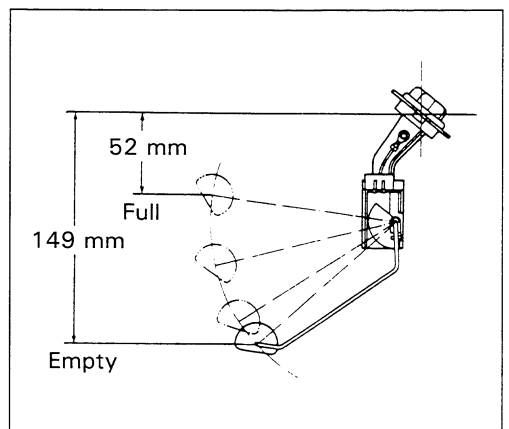

OIL LEVEL INDICATOR SWITCH

Check the oil level indicator switch for continuity between the lead wire.

If the tester does not show the value of 0–1 ohm when the switch ring is in bottom position, file the contact surface or replace the unit.

 **09900-25002: Pocket tester**

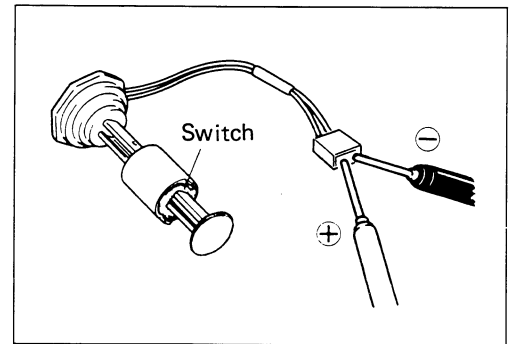

THERMOELEMENT

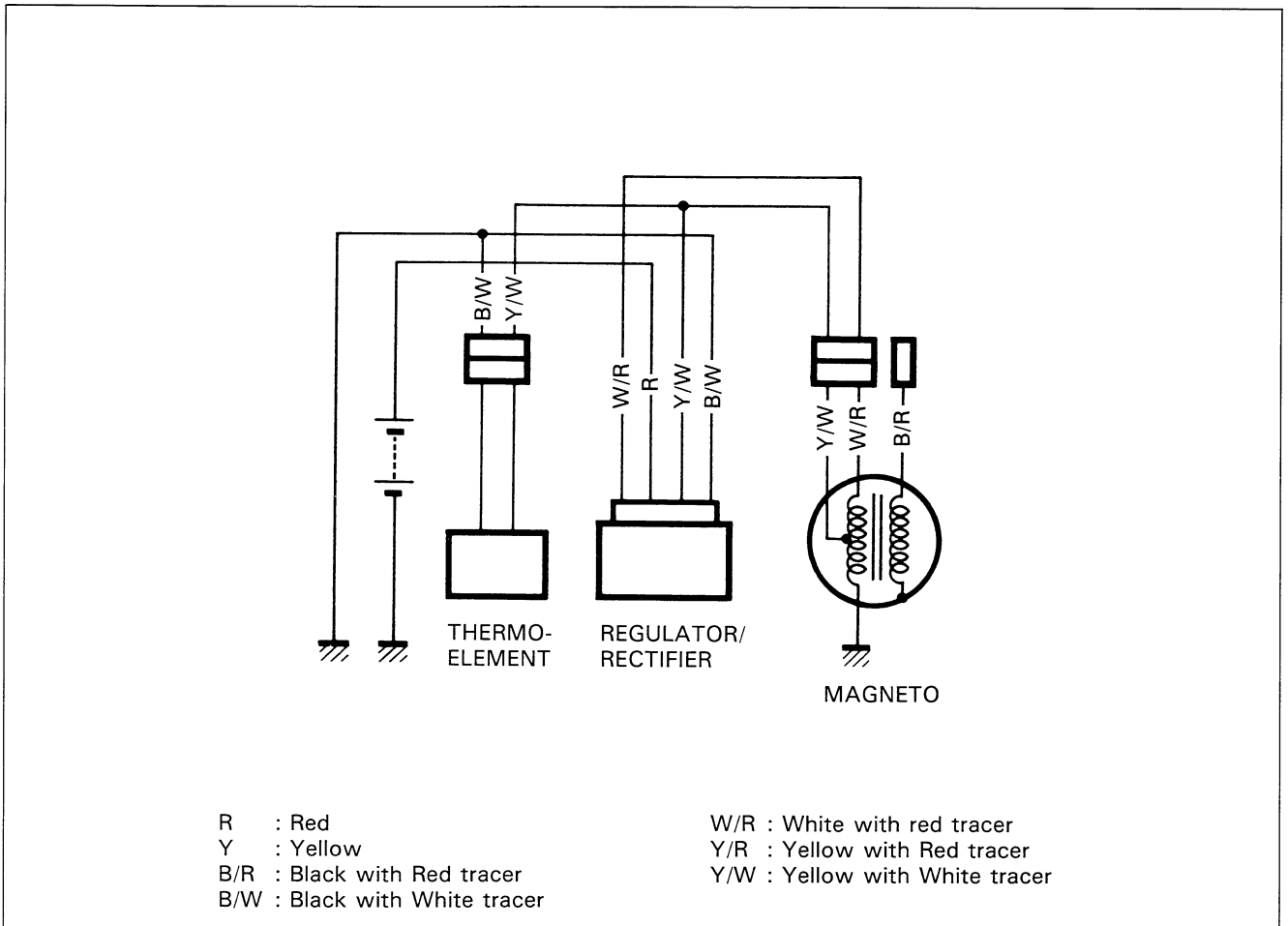

INSPECTION

- Disconnect the thermoelement coupler ①.
- Connect the thermoelement coupler to a 12V battery and touch the thermoelement to check the temperature being raised. The thermoelement should become heated to a temperature more than that of human body within five minutes. If not, replace with new one.

NOTE:

This check should be carried out when the carburetor is cold.

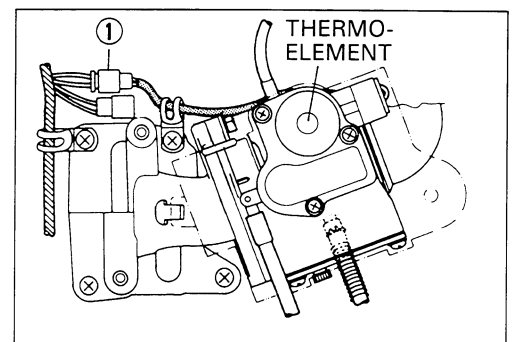

SWITCHES

Inspect each switch for continuity with a pocket tester referring to the chart. If any abnormality is found, replace the respective switch assemblies with new ones.

 **09900-25002: Pocket tester**

 **Tester knob indication: $\times 1\Omega$ range**

IGNITION SWITCH

Position \ Color	B/R	B/W	BI/W	O	R
LOCK					
OFF					
C					
ON					

LIGHTING SWITCH

For Italy and Germany

Position \ Color	G/W	Gr	Y/R	Y/R	G/W	Y/W
OFF						
S						
ON						

For the other models

Position \ Color	G/W	Gr	Y/R	Y/R	Y/W
OFF					
ON					

DIMMER SWITCH (For Spain)

Position \ Color	W	Y	Y/W
HI			
LO			

TURN SIGNAL LIGHT SWITCH

Position \ Color	B	Lbl	Lg
L			
OFF			
R			

STARTER BUTTON

Position \ Color	B/W	Y/G
OFF		
ON (Push)		

HORN BUTTON

Position \ Color	G	B/W
OFF		
ON (Push)		

FRONT BRAKE LIGHT SWITCH

Position \ Color	O	W/B
OFF		
ON		

REAR BRAKE LIGHT SWITCH

Position \ Color	O	W/B
OFF		
ON		

OIL LEVEL SWITCH

Position \ Color	BI/W	B/W
OFF		
ON		

TRUNK LIGHT SWITCH

Position \ Color	R	B/W
OFF (Push)		
ON		

WIRE COLOR

- B : Black
- G : Green
- Gr : Gray
- Lbl : Light blue
- Lg : Light green
- O : Orange
- R : Red
- W : White
- Y : Yellow
- B/R : Black with red tracer
- B/W : Black with White tracer
- BI/W : Blue with White tracer
- G/W : Green with White tracer
- W/B : White with Black tracer
- Y/G : Yellow with Green tracer
- Y/R : Yellow with Red tracer
- Y/W : Yellow with White tracer

BATTERY (For Spain)

SPECIFICATIONS

Type designation	FB4L-B
Capacity	12V, 14.4 kC (4 Ah)/10HR
Standard electrolyte S.G.	1.280 at 20°C (68°F)

In fitting the battery to the motorcycle, connect the breather pipe to the battery vent.

INITIAL CHARGING

Filling electrolyte

Remove the short sealed tube before filling electrolyte. Fill the battery with electrolyte (dilute sulfuric acid solution with acid concentration of 35.0% by weight, having a specific gravity of 1.28 at 20°C (68°F)) up to indicated MAX. LEVEL. Electrolyte should be always cooled below 30°C (86°F) before filling into battery. Leave the battery standing for half an hour after filling. Add additional electrolyte if necessary.

Charge the battery with current as described in the tables shown below.

Maximum charging current: 0.4A

Charging time

The charging time for a new battery is determined by the number of months that have elapsed since the date of manufacture.

Confirmation for date of manufacture

Date of manufacture is indicated by a three-part number ①, as shown in the photograph, each indicating month, date and year.

Near the end of charging period, adjust the specific gravity of electrolyte to value specified. After charging, adjust the electrolyte level to the MAX. LEVEL with DISTILLED WATER.

SERVICING

Visually inspect the surface of the battery container. If any signs of cracking or electrolyte leakage from the sides of the battery have occurred, replace the battery with a new one. If the battery terminals are found to be coated with rust or an acidic white powdery substance, then this can be cleaned away with sandpaper.

Months after manufacturing	Within 6	Within 9	Within 12	Over 12
Necessary charging hours	20	30	40	60

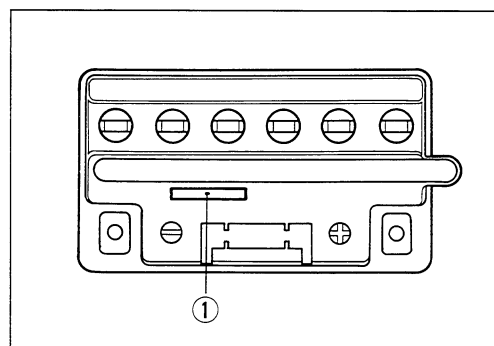
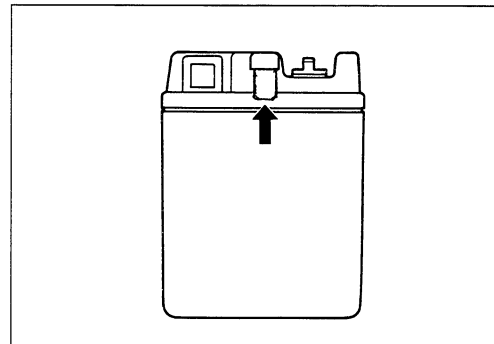

Check the electrolyte level and add distilled water, as necessary to raise the electrolyte to each cell's MAX. LEVEL. Check the battery for proper charge by taking an electrolyte S.G. reading. If the reading is 1.22 or less, as corrected to 20°C (68°F), it means that the battery is still in a run-down condition and needs recharging.

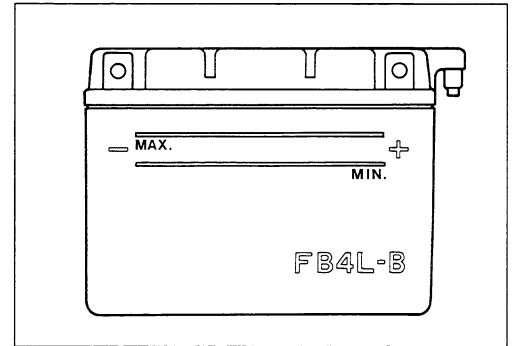

RECHARGING OPERATION BASED ON S.G. READING

To read the S.G. on the hydrometer, bring the electrolyte to eye level and read the graduations on the float scale bordering on the meniscus (curved-up portion of electrolyte surface), as shown in figure.

Check the reading (as corrected to 20°C) with chart to determine the recharging time in hour by constant-current charging at a charging rate of 0.4 amperes (which is tenth of the capacity of the present battery).

Be careful not to permit the electrolyte temperature to exceed 45°C (113°F), at any time, during the recharging operation. Interrupt the operation, as necessary, to let the electrolyte cool down. Recharge the battery to the specification.

Electrolyte specific gravity: 1.280 at 20°C (68°F)

⚠ CAUTION

Constant-voltage charging, otherwise called "quick" charging, is not recommendable for it could shorten the life of the battery.



09900-28403: Hydrometer

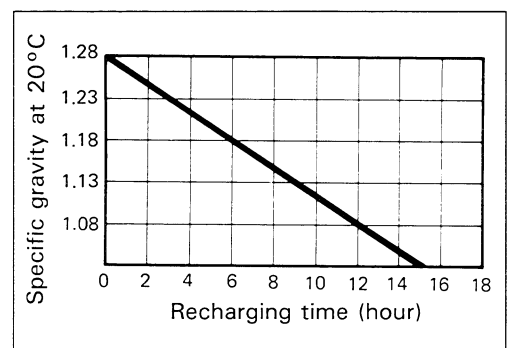
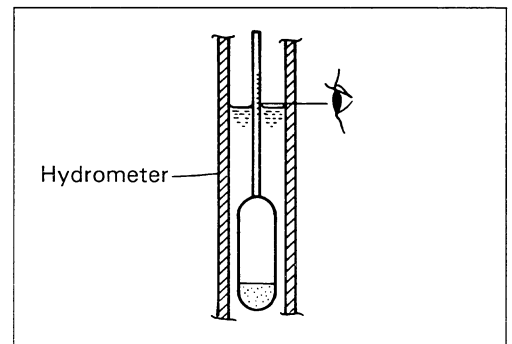
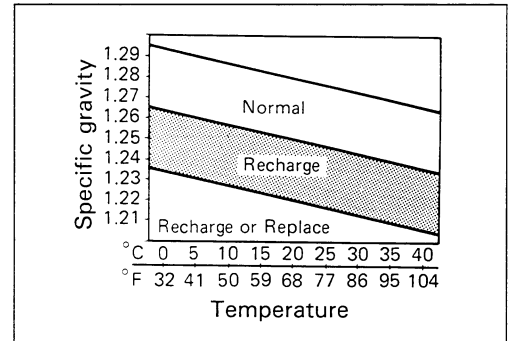

SERVICE LIFE

Lead oxide is applied to the pole plates of the battery which will come off gradually during the service. When the bottom of the battery case becomes full of the sediment, the battery cannot be used any more. If the battery is not charged for a long time, lead sulfate is generated on the surface of the pole plates and will deteriorate the performance (sulfation). Replace the battery with new one in such a case. When a battery is left for a long term without using, it is apt to subject to sulfation. When the motorcycle is not used for more than 1 month (especially during the winter season), recharge the battery once a month at least.

⚠ WARNING

- * Before charging a battery, remove the seal cap from each cell.
- * Keep fire and sparks away from a battery being charged.

⚠ CAUTION

When removing a battery from the motorcycle, be sure to remove the  terminal first.

BATTERY (For the others)

SPECIFICATIONS

Type designation	YT4L-BS
Capacity	12V, 10.8 kC (3 Ah)/10HR
Standard electrolyte S.G.	1.320 at 20°C (68°F)

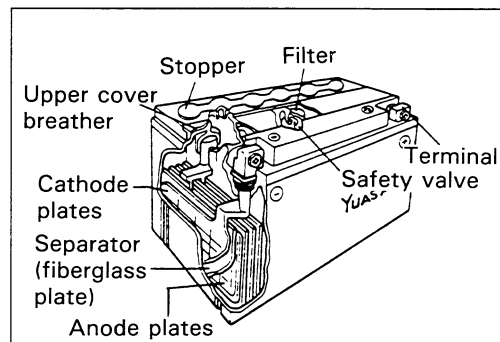

INITIAL CHARGING

Filling electrolyte

- Remove the aluminum tape ① sealing the battery electrolyte filler holes.

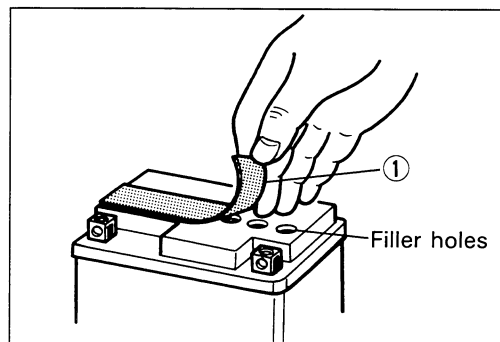

- Remove the caps ②.

NOTE:

- * After filling the electrolyte completely, use the removed cap ② as the sealed caps of battery-filler holes.
- * Do not remove or pierce the sealed areas ③ of the electrolyte container.

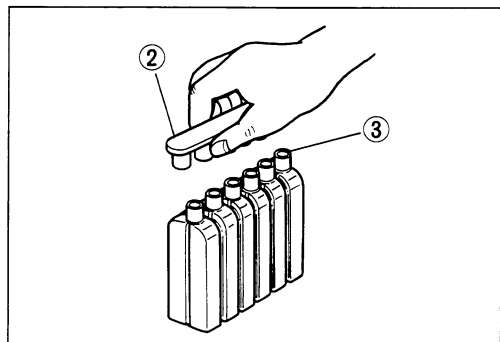

- Insert the nozzles of the electrolyte container into the battery's electrolyte filler holes, holding the container firmly so that it does not fall. Take precaution not to allow any of the fluid to spill.

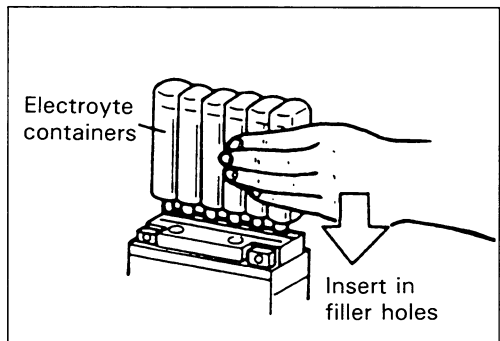

- Make sure air bubbles are coming up each electrolyte container, and leave in this position for about more than 20 minutes.

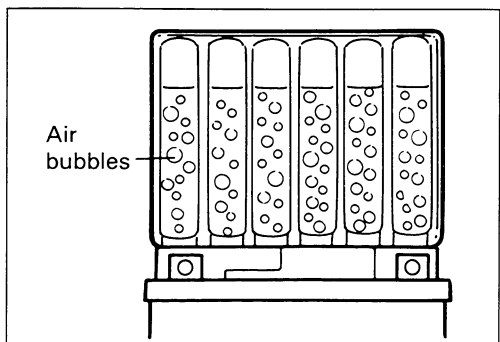

NOTE:

If no air bubbles are coming up from a filler port, tap the bottom of the two or three times.

Never remove the container from the battery.

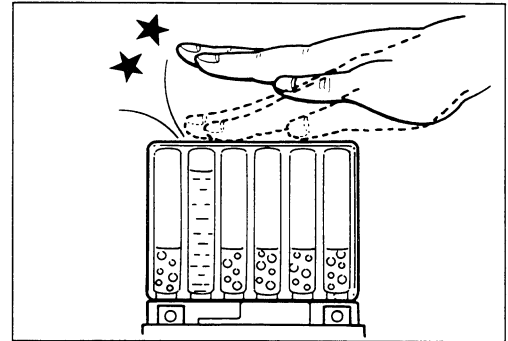

- After confirming that the electrolyte has entered the battery completely, remove the electrolyte containers from the battery. Wait for around 20 minutes.
- Insert the caps into the filler holes, pressing in firmly so that the top of the caps do not protrude above the upper surface of the battery's top cover.

CAUTION

- * **Never use anything except the specified battery.**
- * **Once install the caps to the battery; do not remove the caps.**

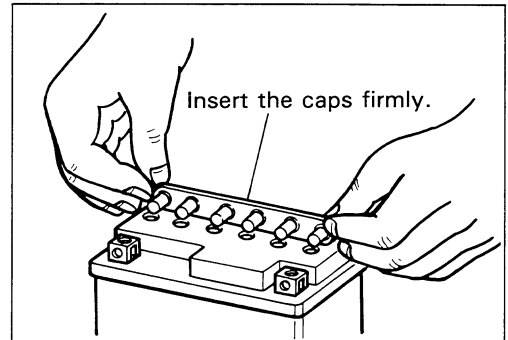

- Using SUZUKI pocket tester, measure the battery voltage. The tester should indicate more than 12.5–12.6V (DC) as shown in the Fig. If the battery voltage is lower than the specification, charge the battery with a battery charger.

NOTE:

Initial charging for a new battery is recommended if two years have elapsed since the date of manufacture.

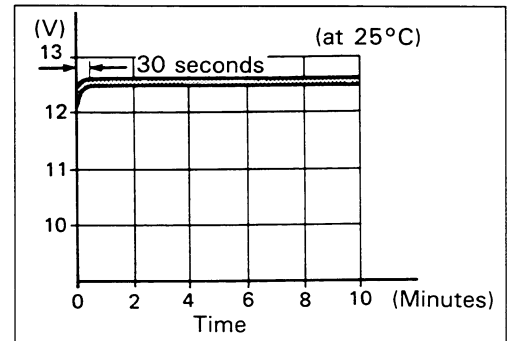

SERVICING

Visually inspect the surface of the battery container. If any signs of cracking or electrolyte leakage from the sides of the battery have occurred, replace the battery with a new one. If the battery terminals are found to be coated with rust or an acidic white powdery substance, then this can be cleaned away with sandpaper.

RECHARGING OPERATION

- Using the pocket tester, check the battery voltage. If the voltage reading is less than the 12.0V (DC), recharge the battery with a battery charger.

⚠ CAUTION

When recharging the battery, remove the battery from the motorcycle.

NOTE:

Do not remove the caps on the battery top while recharging.

Recharging time: 0.4A for 5 hours or 4A for half an hour

⚠ CAUTION

Be careful not to permit the charging current to exceed 4A at any time.

- After recharging, wait for more than 30 minutes and check the battery voltage with a pocket tester.
- If the battery voltage is less than the 12.5V, recharge the battery again.
- If battery voltage is still less than 12.5V, after recharging, replace the battery with a new one.
- When a battery is left for a long term without using, it is subject to discharge. When the motorcycle is not used for more than 1 month (especially during the winter season), check the battery voltage once a month at least.

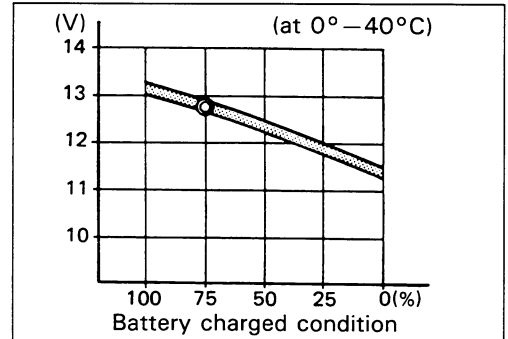
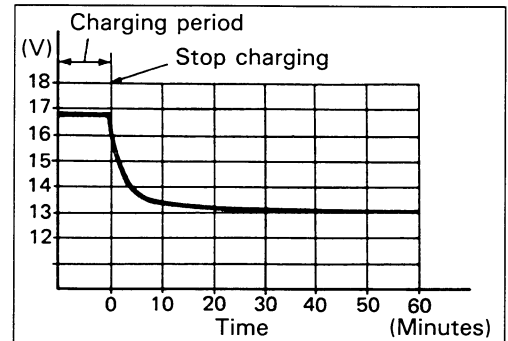

SERVICING INFORMATION

CONTENTS

TROUBLESHOOTING	7- 1
WIRING DIAGRAM	7- 7
WIRE, CABLE AND HOSE ROUTING	7-11
WIRE ROUTING	7-11
CABLE ROUTING	7-13
CARBURETOR AND FUEL HOSE ROUTING	7-14
FRONT BRAKE HOSE ROUTING	7-17
AIR CLEANER INTAKE HOSE, FRONT FENDER	
CUSHION AND CENTER STAND SET-UP	7-18
SPECIAL TOOLS	7-19
TIGHTENING TORQUE	7-21
SERVICE DATA	7-23

TROUBLESHOOTING

ENGINE

Complaint	Symptom and possible causes	Remedy
Engine will not start, or is hard to start.	<p>Compression too low</p> <ol style="list-style-type: none"> 1. Excessively worn cylinder or piston rings. 2. Stiff piston ring in place. 3. Gas leaks from the joint in crankcase, cylinder or cylinder head. 4. Damaged reed valve. 5. Spark plug too loose. 6. Broken, cracked or otherwise failed piston. <p>Plug not sparking</p> <ol style="list-style-type: none"> 1. Damaged spark plug or spark plug cap. 2. Dirty or wet spark plug. 3. Defective CDI/Ignition coil unit or stator coil. 4. Open or short in high-tension cord. 5. Defective ignition switch. <p>No fuel reaching the carburetor</p> <ol style="list-style-type: none"> 1. Clogged hole in the fuel tank cap. 2. Clogged or defective fuel valve. 3. Defective carburetor needle valve. 4. Clogged fuel hose or defective vacuum hose. 	<p>Replace. Repair or replace. Repair or replace.</p> <p>Replace. Tighten. Replace.</p> <p>Replace. Clean and dry. Replace. Replace. Replace.</p> <p>Clean. Clean or replace. Replace. Clean or replace.</p>
Engine stalls easily.	<ol style="list-style-type: none"> 1. Carbon deposited on the spark plug. 2. Defective CDI/Ignition coil. 3. Clogged fuel hose. 4. Clogged jets in carburetor. 5. Clogged exhaust pipe. 	<p>Clean. Replace. Clean. Clean. Clean.</p>
Noisy engine.	<p>Noise appears to come from piston</p> <ol style="list-style-type: none"> 1. Piston or cylinder worn down. 2. Combustion chamber fouled with carbon. 3. Piston pin, bearing or piston pin bore worn. 4. Piston rings or ring grooves worn. <p>Noise seems to come from crankshaft</p> <ol style="list-style-type: none"> 1. Worn or burnt crankshaft bearings. 2. Worn or burnt conrod big-end bearings. <p>Noise seems to come from final gear box</p> <ol style="list-style-type: none"> 1. Gears worn or rubbing. 2. Badly worn splines. 3. Worn or damaged bearings of drive shaft or rear axle shaft. 	<p>Replace. Clean. Replace. Replace.</p> <p>Replace. Replace.</p> <p>Replace. Replace. Replace.</p>
Slipping clutch.	<ol style="list-style-type: none"> 1. Worn or damaged clutch shoes. 2. Worn clutch drum. 	<p>Replace. Replace.</p>

Complaint	Symptom and possible causes	Remedy
Engine idles poorly.	<ol style="list-style-type: none"> 1. Excessively worn cylinder or piston rings. 2. Stiff piston ring in place. 3. Gas leaks from crankshaft oil seal. 4. Spark plug gaps too wide. 5. Defective CDI/Ignition coil unit. 6. Defective stator coil. 7. Float-chamber fuel level out of adjustment in carburetor. 8. Clogged jets of carburetor. 9. Broken or damaged reed valve. 	<p>Replace. Replace. Replace. Adjust or replace. Replace. Replace. Replace.</p> <p>Clean or adjust. Replace.</p>
Engine runs poorly in high-speed range.	<ol style="list-style-type: none"> 1. Excessively worn cylinder or piston rings. 2. Stiff piston ring in place. 3. Spark plug gaps too narrow. 4. Ignition not advanced sufficiently due to poorly working CDI/Ignition coil unit. 5. Defective stator coil. 6. Float-chamber fuel level too low. 7. Clogged air cleaner element. 8. Clogged fuel hose, resulting in inadequate fuel supply to carburetor. 9. Clogged fuel valve vacuum pipe. 	<p>Replace. Replace. Adjust. Replace.</p> <p>Replace. Replace. Clean. Clean and prime.</p> <p>Clean.</p>
Dirty or heavy exhaust smoke.	<ol style="list-style-type: none"> 1. Use of incorrect engine oil. 	<p>Change.</p>
Engine lacks power.	<ol style="list-style-type: none"> 1. Excessively worn cylinder or piston rings. 2. Stiff piston rings in place. 3. Gas leaks from crankshaft oil seal. 4. Spark plug gaps incorrect. 5. Clogged jets in carburetor. 6. Float-chamber fuel level out of adjustment. 7. Clogged air cleaner element. 8. Fouled spark plug. 9. Sucking air from intake pipe. 10. Slipping or worn V-belt. 11. Damaged/worn rollers in the movable drive face. 12. Weakened movable driven face spring. 13. Too rich fuel/air mixture due to defective starter system. 	<p>Replace. Replace. Replace. Adjust or replace. Clean. Replace. Clean. Clean or replace. Retighten or replace. Replace. Replace. Replace. Replace.</p>
Engine overheats.	<ol style="list-style-type: none"> 1. Heavy carbon deposit on piston crown. 2. Defective oil pump or clogged oil circuit. 3. Fuel level too low in float chamber. 4. Air leakage from intake pipe. 5. Use of incorrect engine oil. 6. Use of improper spark plug. 7. Clogged exhaust pipe/muffler. 	<p>Clean. Replace or clean. Replace. Retighten or replace. Change. Change. Clean or replace.</p>

CARBURETOR

Complaint	Symptom and possible causes	Remedy
Trouble with starting.	<ol style="list-style-type: none"> 1. Starter jet is clogged. 2. Air leaking from a joint between starter body and carburetor. 3. Air leaking from carburetor's joint or vacuum hose joint. 4. Starter plunger is not operating properly. 	<p>Clean. Check starter body and carburetor for tightness, and replace gasket. Check and replace.</p> <p>Check and replace.</p>
Idling or low-speed trouble.	<ol style="list-style-type: none"> 1. Pilot jet, pilot air jet are clogged or loose. 2. Air leaking from carburetor's joint, vacuum pipe joint, or starter. 3. Pilot outlet is clogged. 4. Thermostatic element is not operating properly. 	<p>Check and clean. Clean and replace.</p> <p>Check and clean. Check and replace.</p>
Medium- or high-speed trouble.	<ol style="list-style-type: none"> 1. Main jet or main air jet is clogged. 2. Needle jet is clogged. 3. Fuel level is improperly set. 4. Throttle valve is not operating properly. 5. Fuel filter is clogged. 	<p>Check and clean. Check and clean. Check and replace. Check throttle valve for operation. Check and clean.</p>
Overflow and fuel level fluctuations.	<ol style="list-style-type: none"> 1. Needle valve is worn or damaged. 2. Spring in needle valve is broken. 3. Float is not working properly. 4. Foreign matter has adhered to needle valve. 5. Fuel level is too high or low. 	<p>Replace. Replace. Check and adjust. Clean. Replace.</p>

ELECTRICAL

Complaint	Symptom and possible causes	Remedy
No sparking or poor sparking.	<ol style="list-style-type: none"> 1. Defective CDI/Ignition coil unit. 2. Defective spark plug. 3. Defective stator coil. 4. Loose connection of lead wire. 	<p>Replace. Replace. Replace. Connect/tighten.</p>
Spark plug soon becomes fouled with carbon.	<ol style="list-style-type: none"> 1. Mixture too rich. 2. Idling speed set too high. 3. Incorrect gasoline. 4. Dirty element in air cleaner. 5. Spark plug too cold. 6. Incorrect engine oil. 	<p>Adjust carburetor. Adjust carburetor. Change. Clean. Replace by hot type plug. Replace.</p>
Spark plug electrodes overheat or burn.	<ol style="list-style-type: none"> 1. Spark plug too hot. 2. The engine overheats. 3. Spark plug loose. 4. Mixture too lean. 5. Not enough engine oil. 	<p>Replace by cold type plug. Turn up. Retighten. Adjust carburetor. Check oil pump.</p>
Magneto does not charge.	<ol style="list-style-type: none"> 1. Open or short in lead wires, or loose lead connections. 2. Shorted, grounded or open magneto coil. 3. Shorted or open regulator/rectifier. 	<p>Repair, replace or retighten. Replace. Replace.</p>
Magneto charge, but charging rate is below the specifications.	<ol style="list-style-type: none"> 1. Lead wires tend to get shorted or open-circuited or loosely connected at terminal. 2. Grounded or open-circuited stator coils of magneto. 3. Defective regulator/rectifier. 4. Defective cell plates in the battery. 	<p>Repair or retighten.</p> <p>Replace. Replace. Replace the battery.</p>

Complaint	Symptom and possible causes	Remedy
Magneto overcharges.	<ol style="list-style-type: none"> 1. Internal short-circuit in the battery. 2. Resistor element in the regulator/rectifier damaged or defective. 3. Regulator/rectifier unit poorly grounded. 	<p>Replace the battery. Replace.</p> <p>Clean and tighten ground connection.</p>
Unstable charging.	<ol style="list-style-type: none"> 1. Lead wire insulation frayed due to vibration, resulting in intermittent shorting. 2. Magneto coil internally shorted. 3. Defective regulator/rectifier. 	<p>Repair or replace.</p> <p>Replace. Replace.</p>
Starter button is not effective.	<ol style="list-style-type: none"> 1. Battery run down. 2. Defective switch contacts. 3. Brushes not seating properly on commutator in starter motor. 4. Defective starter relay. 5. Defective starter pinion gears. 6. Defective front or rear brake light switch circuit. 	<p>Recharge or replace. Replace. Repair or replace.</p> <p>Replace. Replace. Replace/repair.</p>

BATTERY (For Spain)

Complaint	Symptom and possible causes	Remedy
“Sulfation”, acidic white powdery substance or spots on surfaces of cell plates.	<ol style="list-style-type: none"> 1. Not enough electrolyte. 2. Battery case is cracked. 3. Battery has been left in a run-down condition for a long time. 4. Adulterated electrolyte (Foreign matter has entered the battery and become mixed with the electrolyte). 	<p>Add distilled water, if the battery has not been damaged and “sulfation” has not advanced too far, and recharge.</p> <p>Replace the battery. Replace the battery.</p> <p>If “sulfation” has not advanced too far, try to restore the battery by replacing the electrolyte, recharging it fully with the battery detached from the motorcycle and then adjusting electrolyte S.G.</p>
Battery runs down quickly.	<ol style="list-style-type: none"> 1. The charging method is not correct. 2. Cell plates have lost much of their active material as a result of over-charging. 3. A short-circuit condition exists within the battery due to excessive accumulation of sediments caused by the high electrolyte S.G. 4. Electrolyte S.G. is too low. 5. Adulterated electrolyte. 6. Battery is too old. 	<p>Check the generator, regulator/rectifier and circuit connections, and make necessary adjustments to obtain specified charging operation.</p> <p>Replace the battery, and correct the charging system. Replace the battery.</p> <p>Recharge the battery fully and adjust electrolyte S.G. Replace the electrolyte, recharge the battery and then adjust S.G. Replace the battery.</p>
Reversed battery polarity.	<p>The battery has been connected the wrong way round in the system, so that it is being charged in the reverse direction.</p>	<p>Replace the battery and be sure to connect the battery properly.</p>

7-5 SERVICING INFORMATION

Complaint	Symptom and possible causes	Remedy
Battery "sulfation"	<ol style="list-style-type: none"> 1. Charging rate too low or too high. (When not in use battery should be recharged at least once a month to avoid sulfation). 2. Battery electrolyte excessive or insufficient, or its specific gravity too high or too low. 3. The battery left unused for too long in cold climate. 	<p>Replace the battery.</p> <p>Keep the electrolyte up to the prescribed level, or adjust the S.G. by consulting the battery maker's directions.</p> <p>Replace the battery, if badly sulfated.</p>
Battery discharges too rapidly.	<ol style="list-style-type: none"> 1. Dirty container top and sides. 2. Impurities in the electrolyte or electrolyte S.G. is too high. 	<p>Clean.</p> <p>Change the electrolyte by consulting the battery maker's directions.</p>

BATTERY (For the others)

Complaint	Symptom and possible causes	Remedy
Battery runs down quickly.	<ol style="list-style-type: none"> 1. The charging method is not correct. 2. Cell plates have lost much of their active material as a result of over-charging. 3. A short-circuit condition exists within the battery due to excessive accumulation of sediments caused by the incorrect electrolyte. 4. Battery is too old. 	<p>Check the magneto and regulator/rectifier circuit connections, and make necessary adjustment to obtain specified charging operation.</p> <p>Replace the battery, and correct the charging system.</p> <p>Replace the battery.</p> <p>Replace the battery.</p>
Reversed battery polarity.	<ol style="list-style-type: none"> 1. The battery has been connected the wrong way round in the system, so that it is being charged in the reverse direction. 	<p>Replace the battery and be sure to connect the battery properly.</p>
Battery discharges too rapidly.	<ol style="list-style-type: none"> 1. Dirty container top and sides. 2. Battery is too old. 	<p>Clean.</p> <p>Replace.</p>

CHASSIS

Complaint	Symptom and possible causes	Remedy
Handling feels too heavy.	<ol style="list-style-type: none"> 1. Steering stem nut overtightened. 2. Broken bearing/race in steering stem. 3. Distorted steering stem. 4. Not enough pressure in tires. 	<p>Adjust.</p> <p>Replace.</p> <p>Replace.</p> <p>Adjust.</p>
Wobbly handle.	<ol style="list-style-type: none"> 1. Loss of balance between right and left front suspension. 2. Distorted front axle or crooked tire. 	<p>Replace.</p> <p>Replace.</p>
Wobbly front wheel.	<ol style="list-style-type: none"> 1. Distorted wheel rim. 2. Worn front wheel bearings. 3. Defective or incorrect tire. 4. Loose nut on axle. 5. Loose bolts on the rear shock absorber. 6. Worn engine mounting bushing. 7. Loose nuts or bolts for engine mounting. 	<p>Replace.</p> <p>Replace.</p> <p>Replace.</p> <p>Retighten.</p> <p>Retighten.</p> <p>Replace.</p> <p>Tighten.</p>

Complaint	Symptom and possible causes	Remedy
Front suspension too soft.	<ol style="list-style-type: none"> 1. Weakened springs. 2. Not enough fork oil. 	Replace. Refill.
Front suspension too stiff.	<ol style="list-style-type: none"> 1. Fork oil too viscous. 2. Too much fork oil. 	Replace. Drain excess oil.
Noisy front suspension.	<ol style="list-style-type: none"> 1. Not enough fork oil. 2. Loose bolts or nuts on suspension 	Refill. Retighten.
Wobbly rear wheel.	<ol style="list-style-type: none"> 1. Distorted wheel rim. 2. Defective or incorrect tire. 3. Loose bolts on the rear shock absorber. 4. Worn engine mounting bushing. 5. Loose nuts or bolts for engine mounting. 	Replace. Replace. Replace. Replace. Retighten.
Rear suspension too soft.	<ol style="list-style-type: none"> 1. Weakened spring. 2. Oil leakage of rear shock absorber. 	Replace. Replace.
Noisy rear suspension.	<ol style="list-style-type: none"> 1. Loose nuts on suspension unit. 2. Worn engine mounting bushing. 	Retighten. Replace.

BRAKES

Complaint	Symptom and possible causes	Remedy
Insufficient brake power.	<ol style="list-style-type: none"> 1. Leakage of brake fluid from hydraulic system. 2. Worn pad. 3. Oil adhesion on engaging surface of pad. 4. Worn disc. 5. Air entered into hydraulic system. 6. Worn shoe. 7. Friction surfaces of shoes are dirty with oil. 8. Excessively worn drum. 9. Too much brake lever play. 	Repair or replace. Replace. Clean disc and pads. Replace. Bleed air. Replace. Replace. Replace. Adjust.
Brake squeaking.	<ol style="list-style-type: none"> 1. Carbon adhesion on pad surface. 2. Tilted pad. 3. Damaged wheel bearing. 4. Worn pad. 5. Foreign substance entered into brake fluid. 6. Clogged return port of master cylinder. 7. Brake shoe surface glazed. 8. Loose front-wheel axle or rear-wheel axle nut. 9. Worn shoe. 	Repair surface with sandpaper. Modify and fitting. Replace. Replace. Replace brake fluid. Disassemble and clean master cylinder. Repair surface with sandpaper. Tighten to specified torque. Replace.
Excessive brake lever stroke.	<ol style="list-style-type: none"> 1. Air entered into hydraulic system. 2. Insufficient brake fluid. 3. Improper quality of brake fluid. 4. Worn brake cam lever. 5. Excessively worn shoes and/or drum. 	Bleed air. Replenish fluid to normal lever; bleed air. Replace with correct fluid. Replace. Replace.
Leakage of brake fluid.	<ol style="list-style-type: none"> 1. Insufficient tightening of connection joints. 2. Cracked hose. 3. Worn piston seal. 	Tighten to specified torque. Replace. Replace
Brake drags.	<ol style="list-style-type: none"> 1. Rusty moving parts. 	Clean and lubricate.

WIRING DIAGRAM

For France

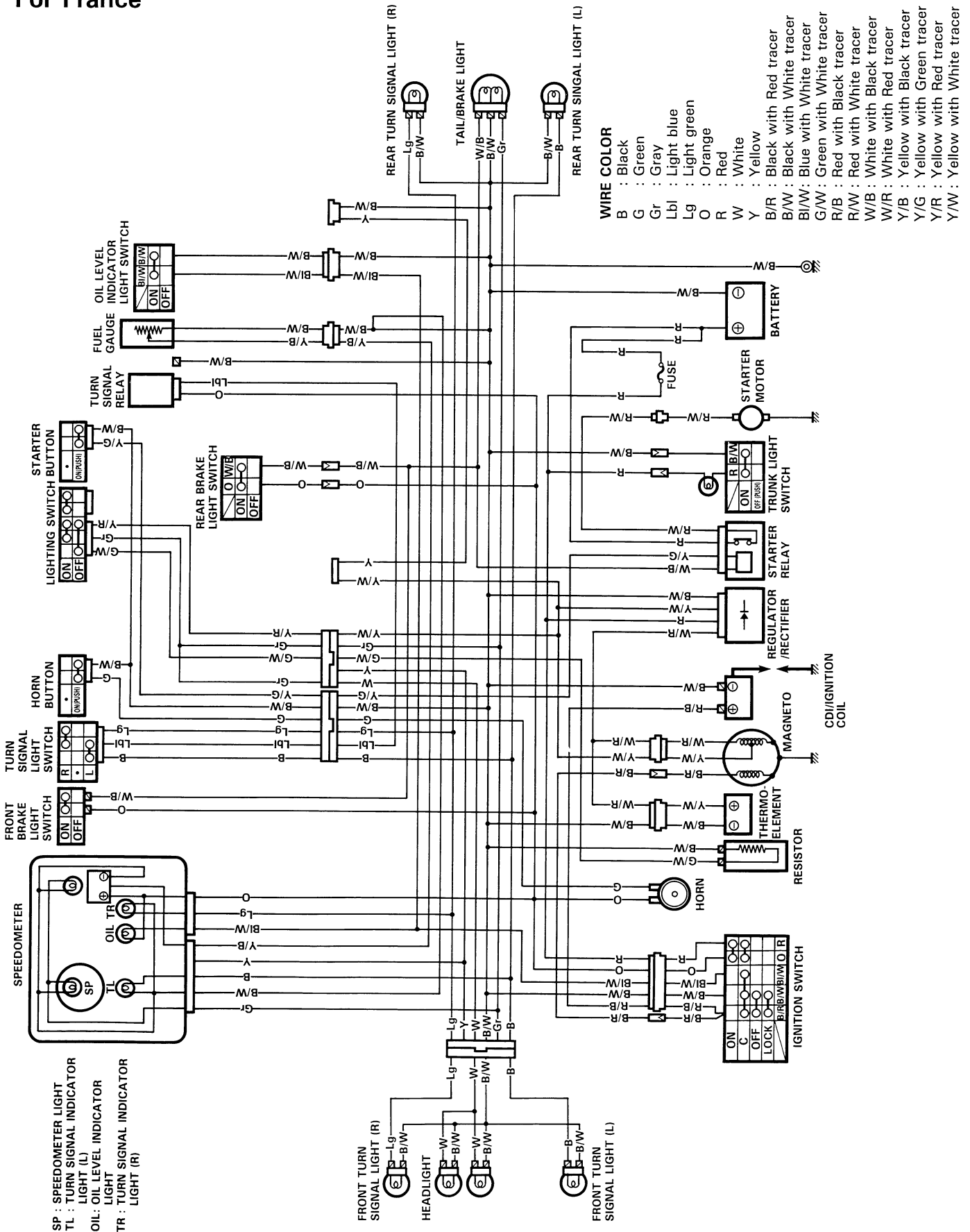

For Germany

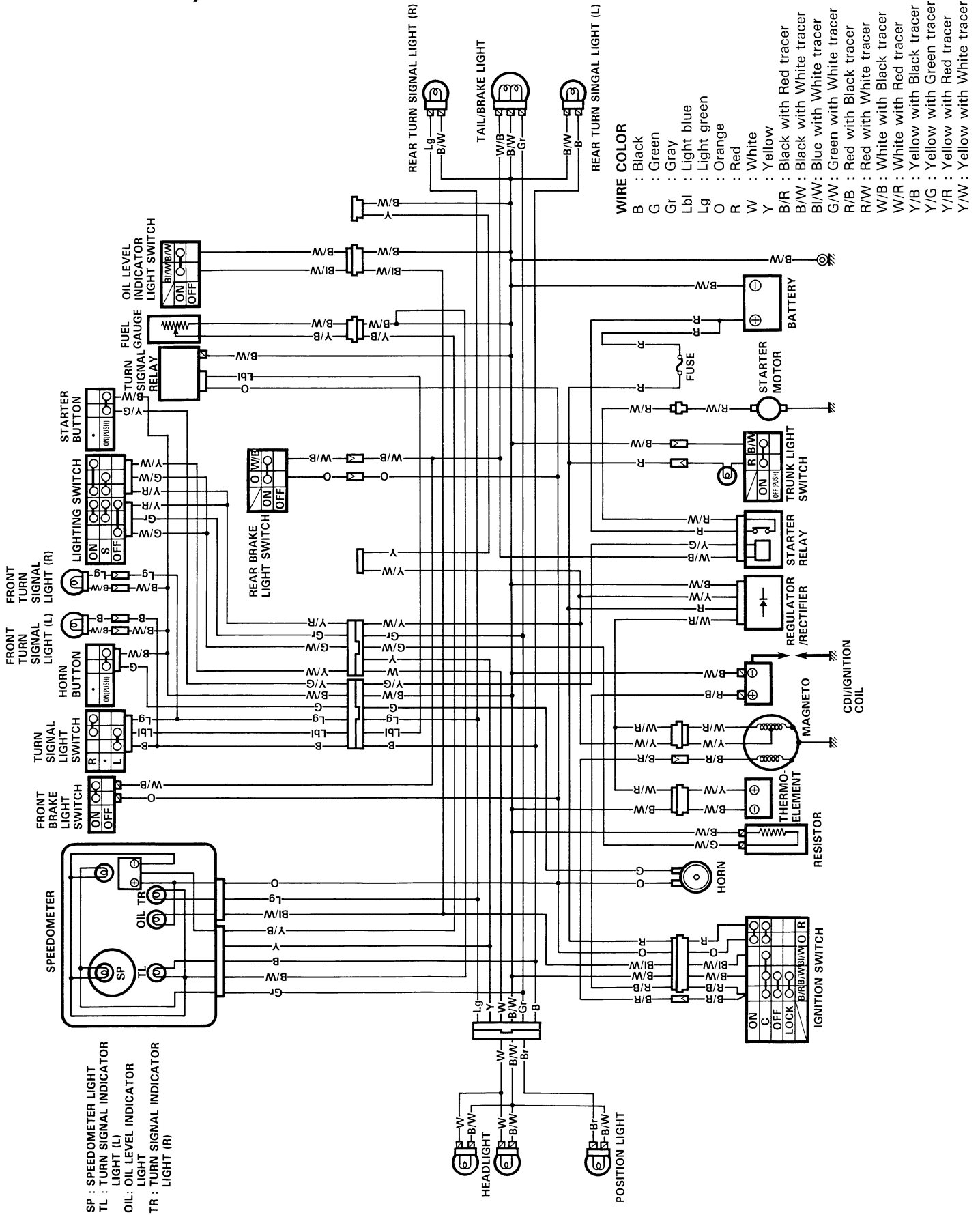

For Italy

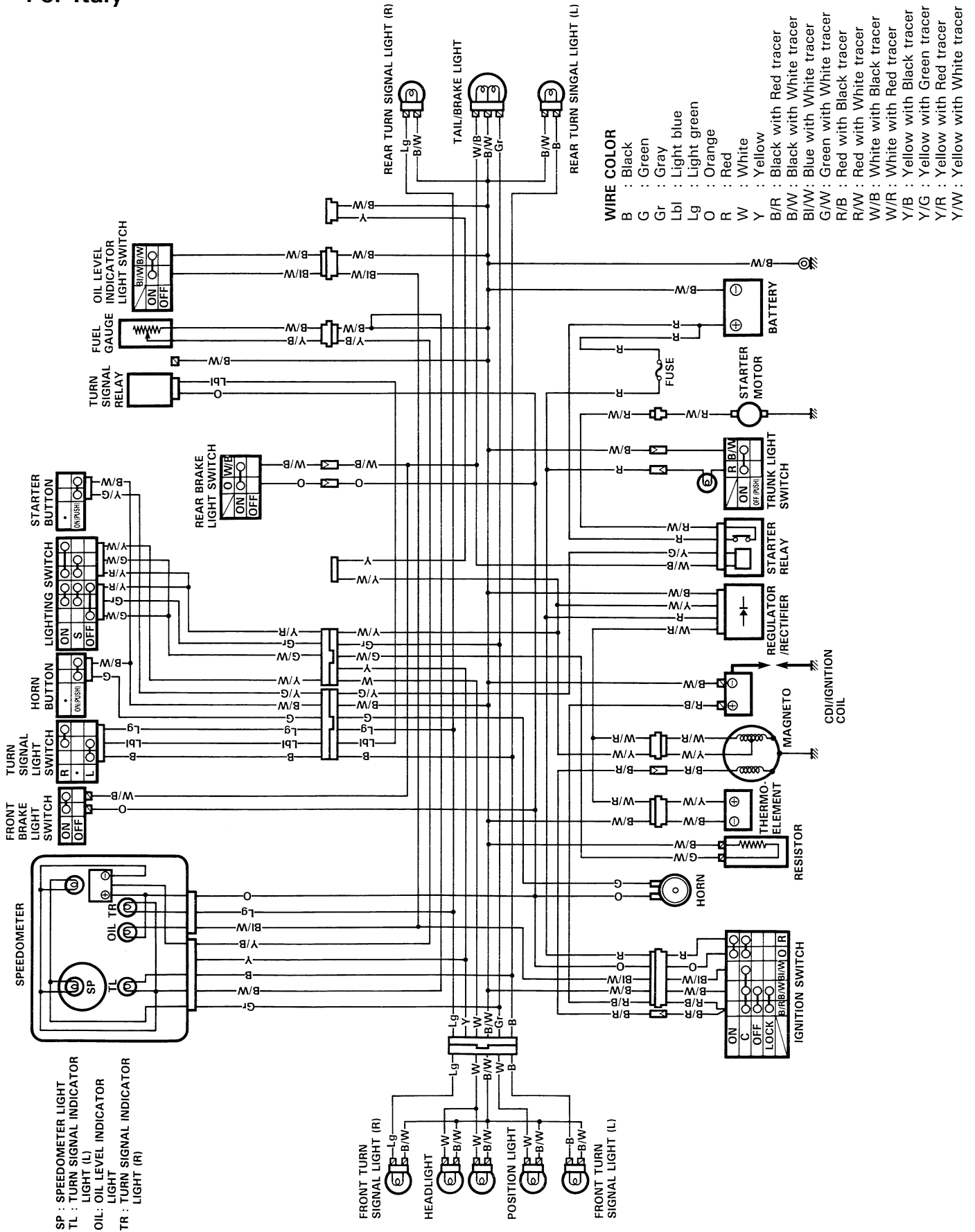

For Spain

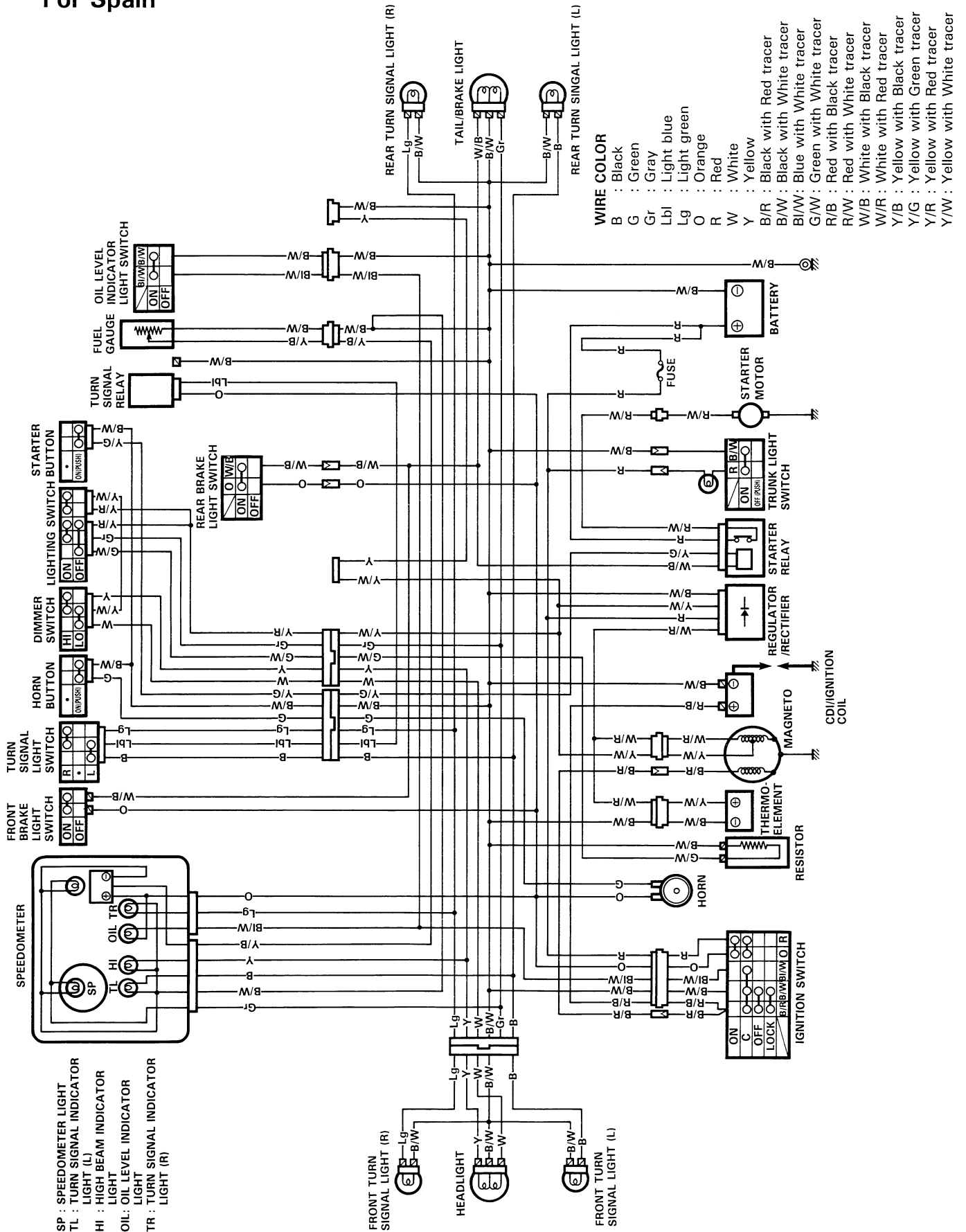

WIRE, CABLE AND HOSE ROUTING

WIRE ROUTING

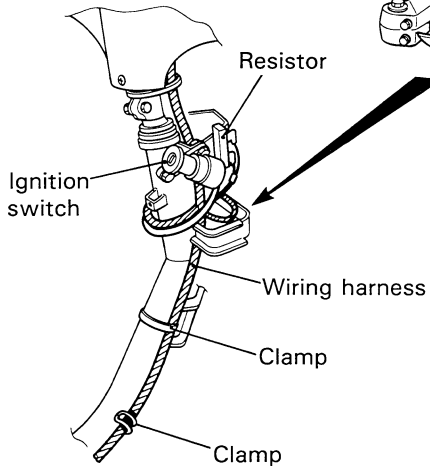
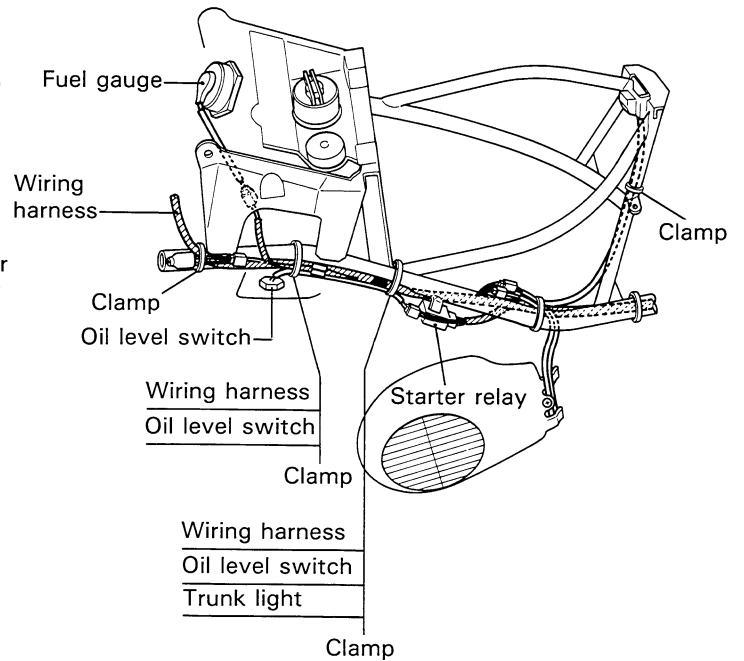
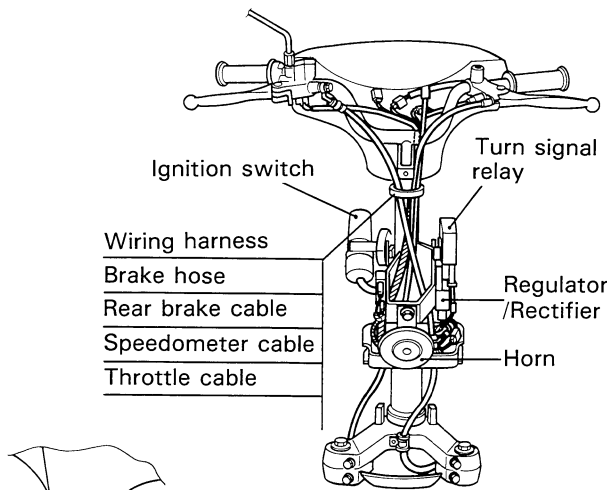
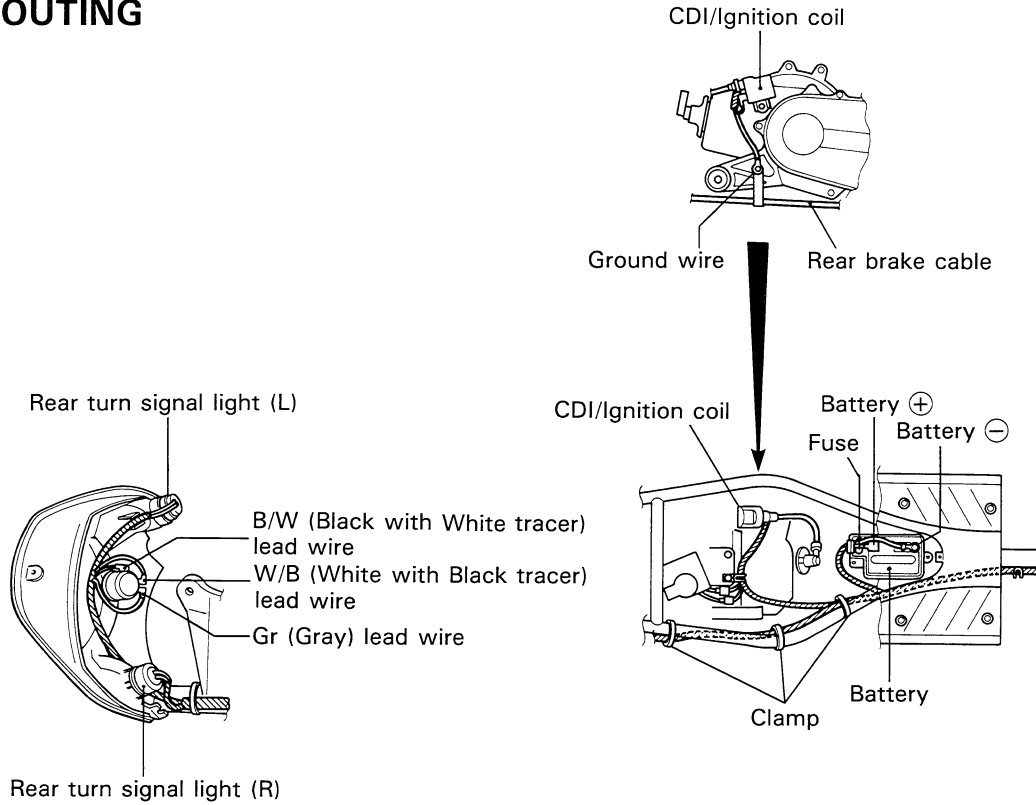

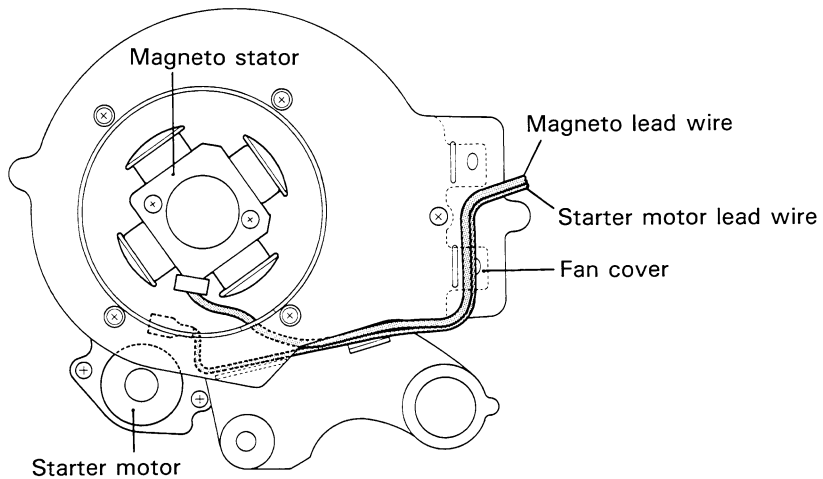
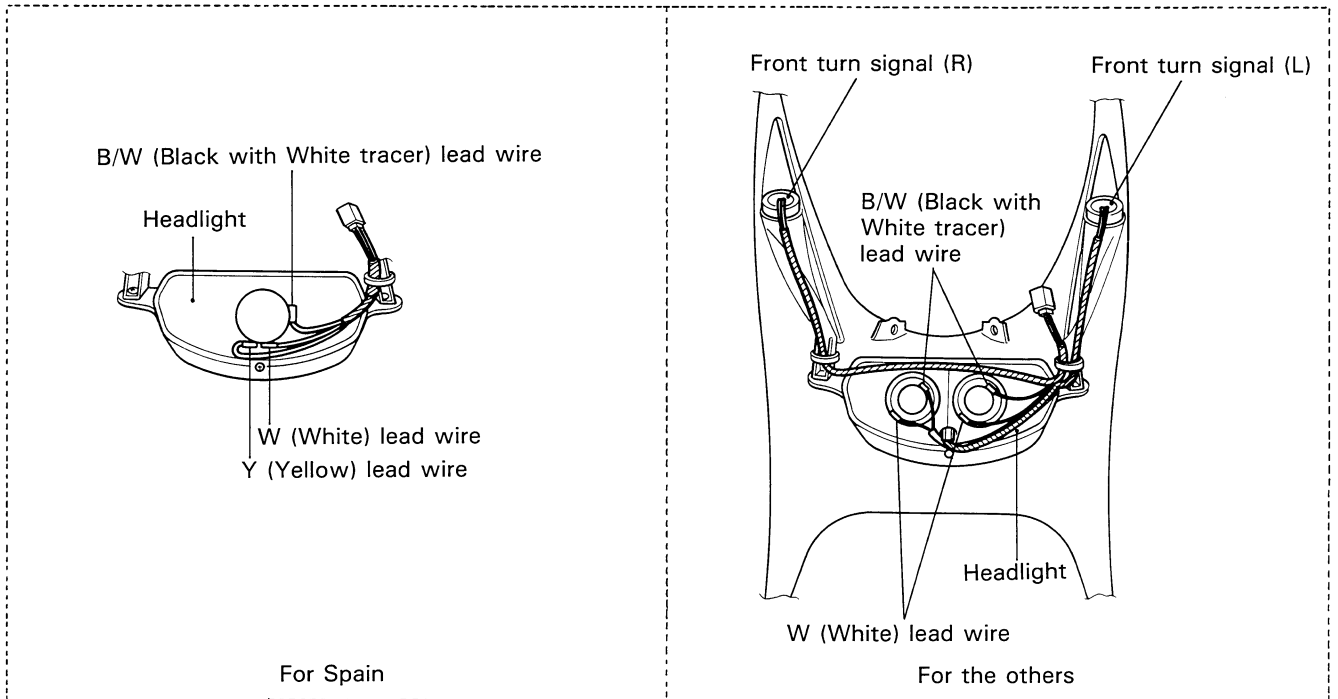
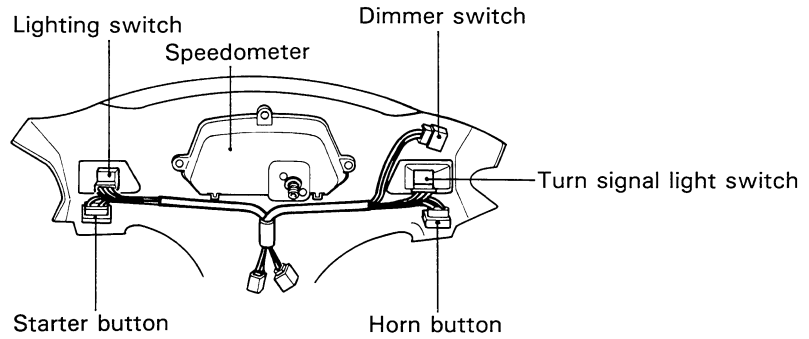

CABLE ROUTING

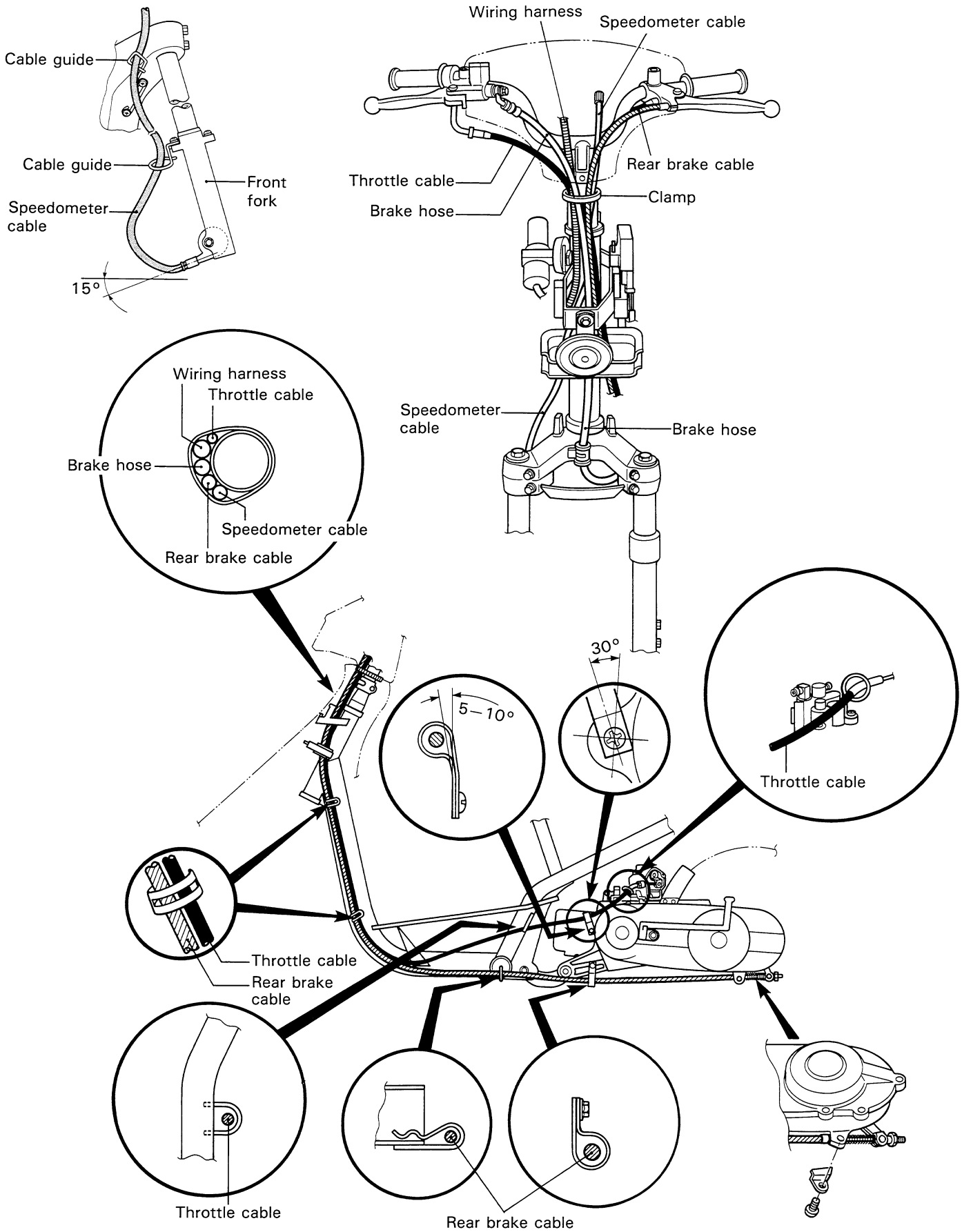

CARBURETOR AND FUEL HOSE ROUTING

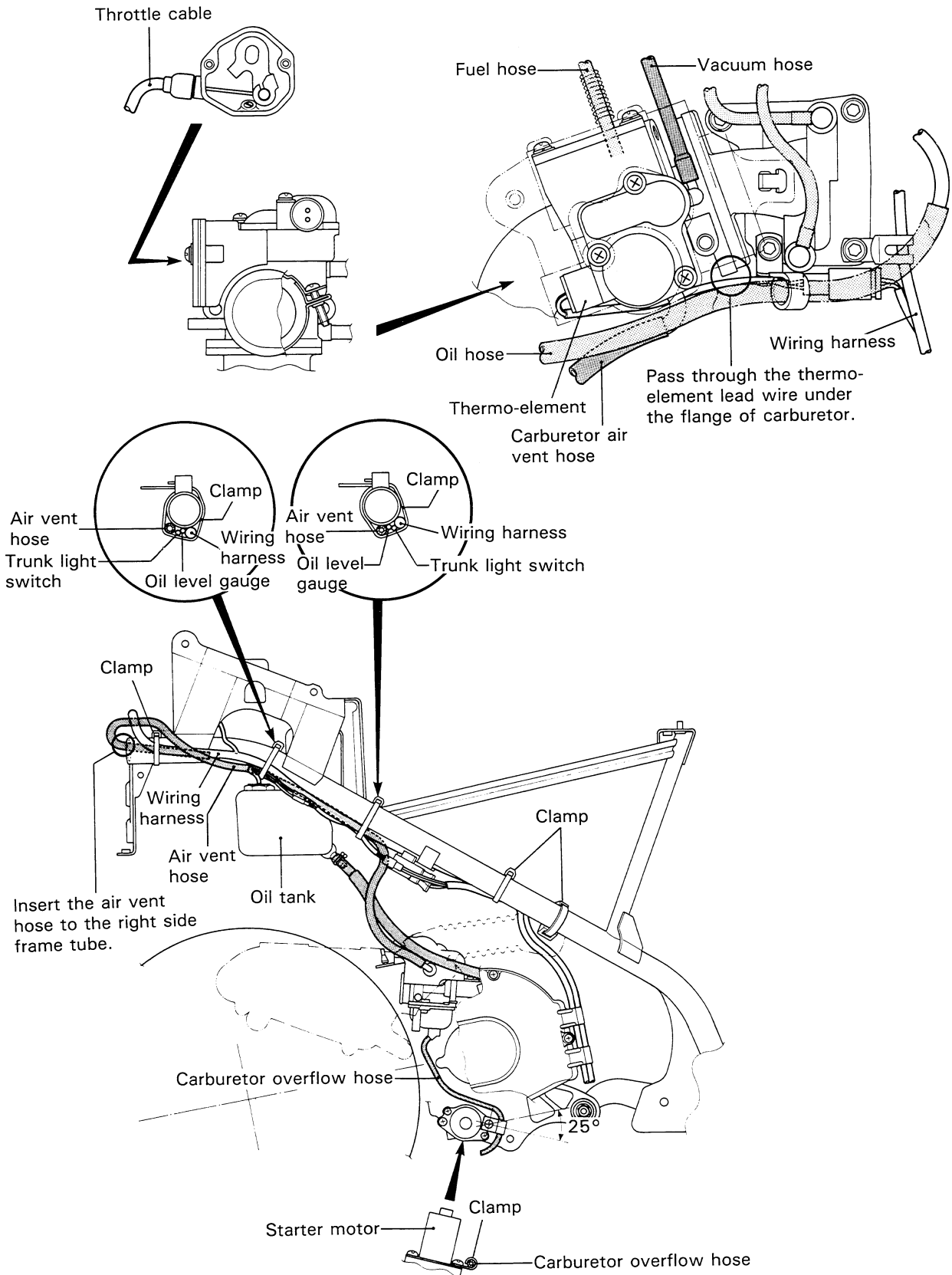

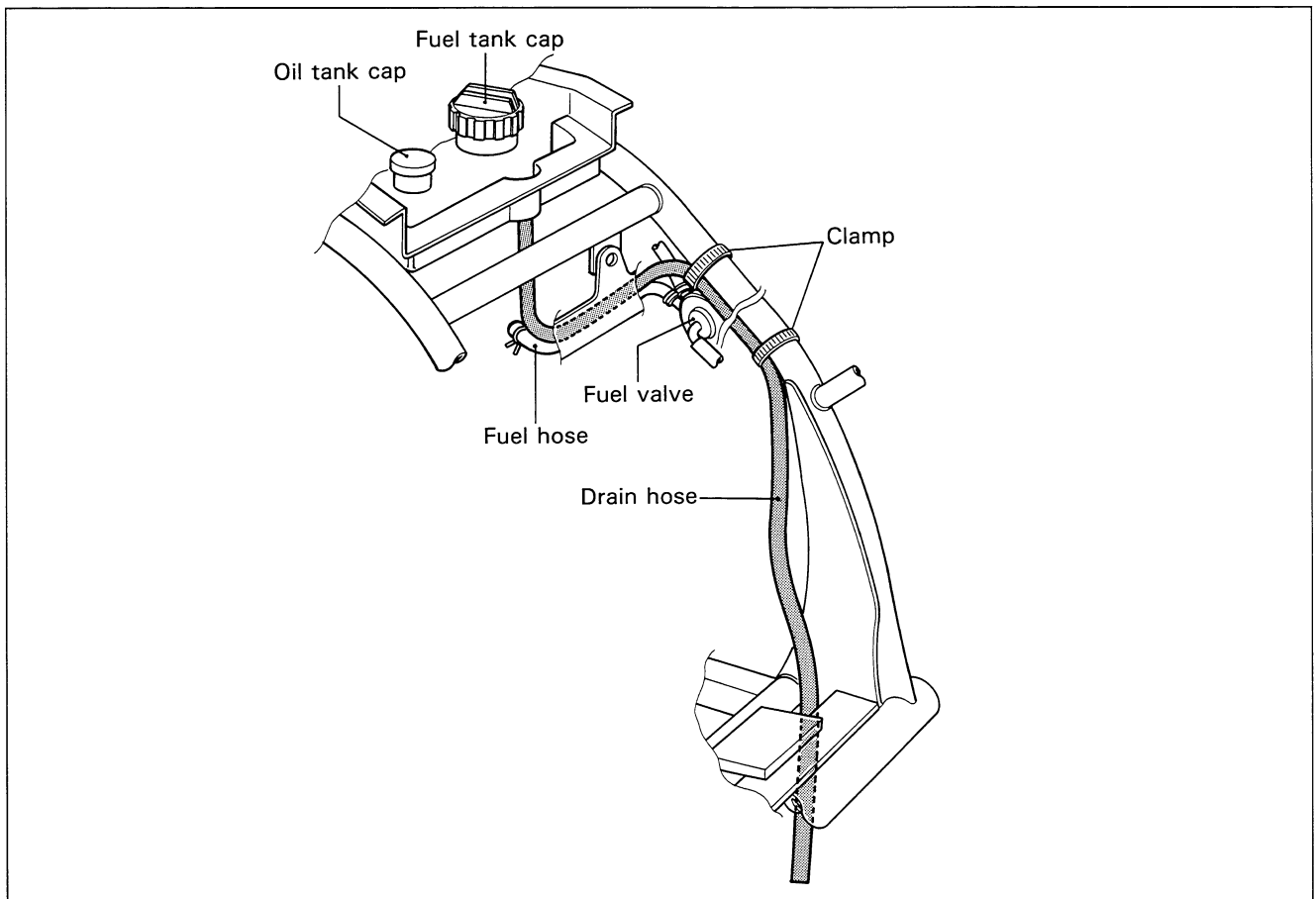
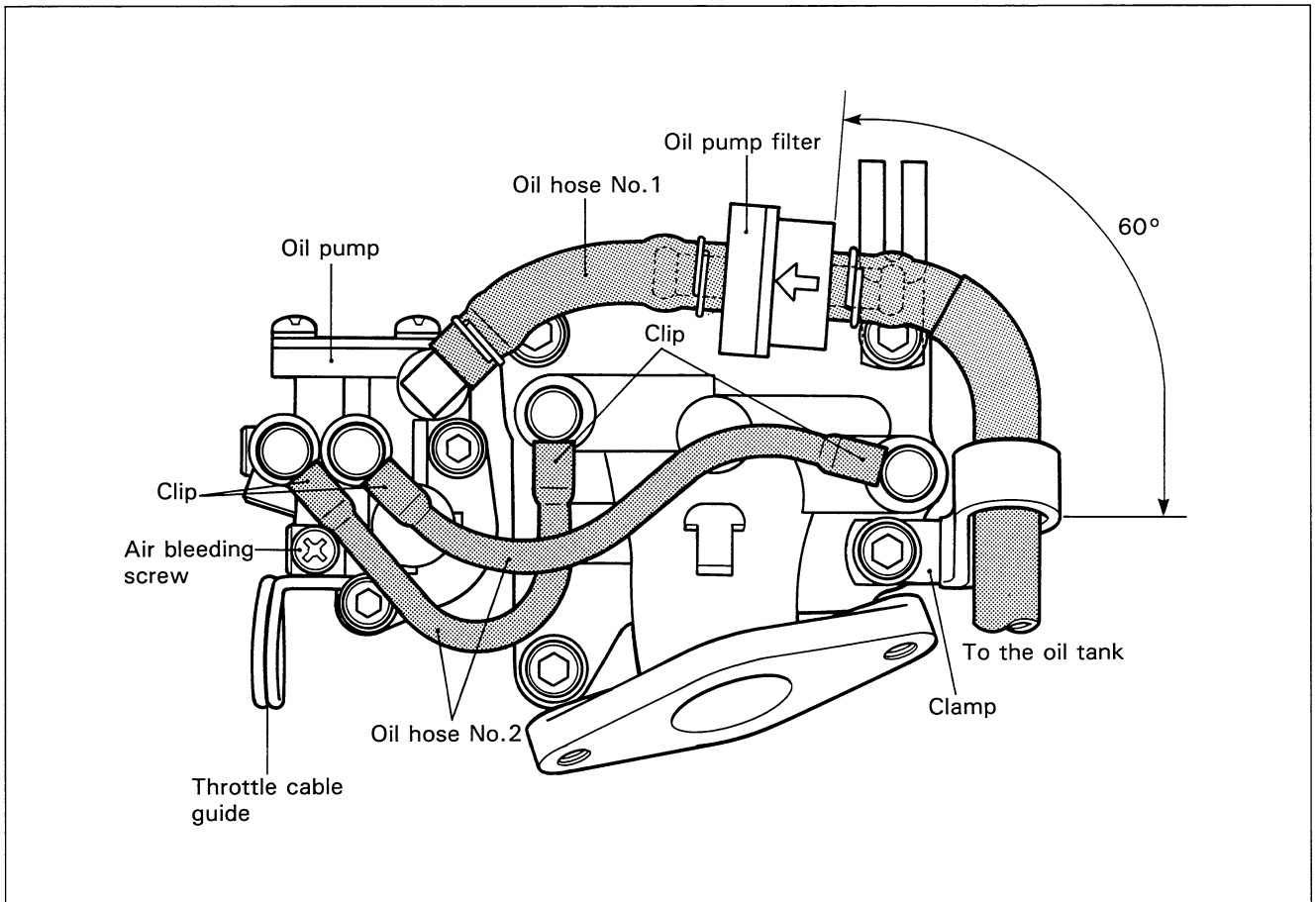

For France

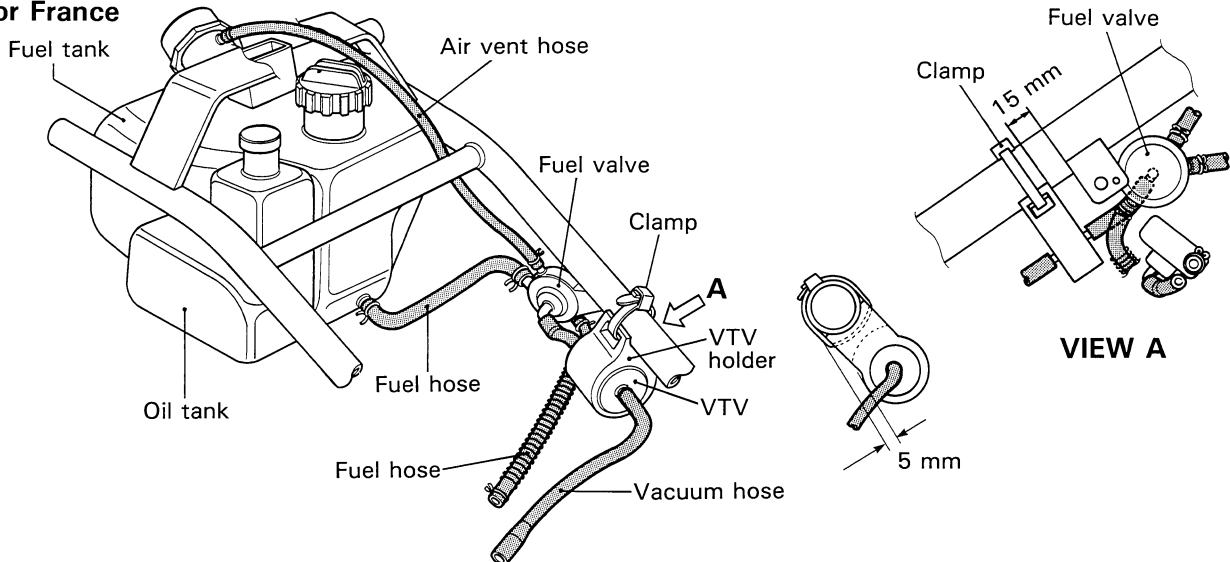

For Spain

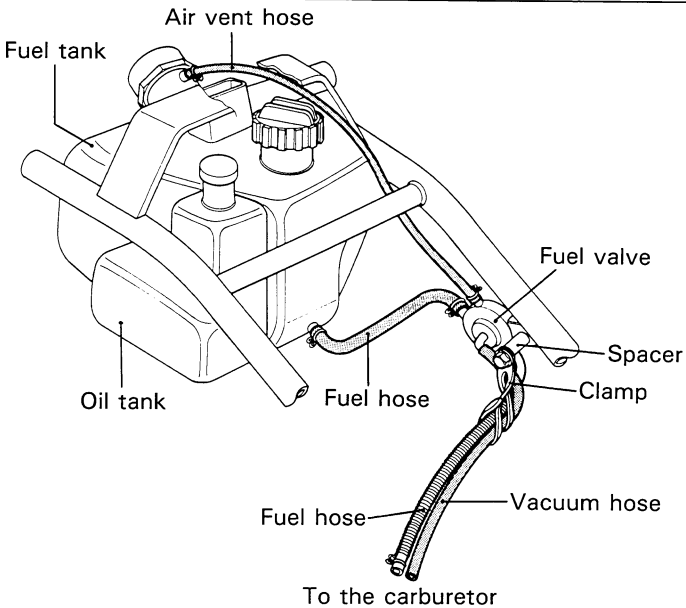

For the others

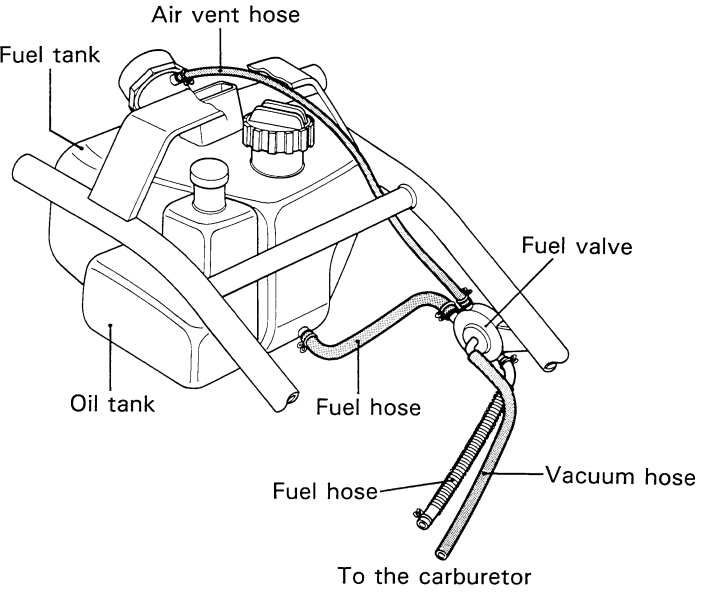



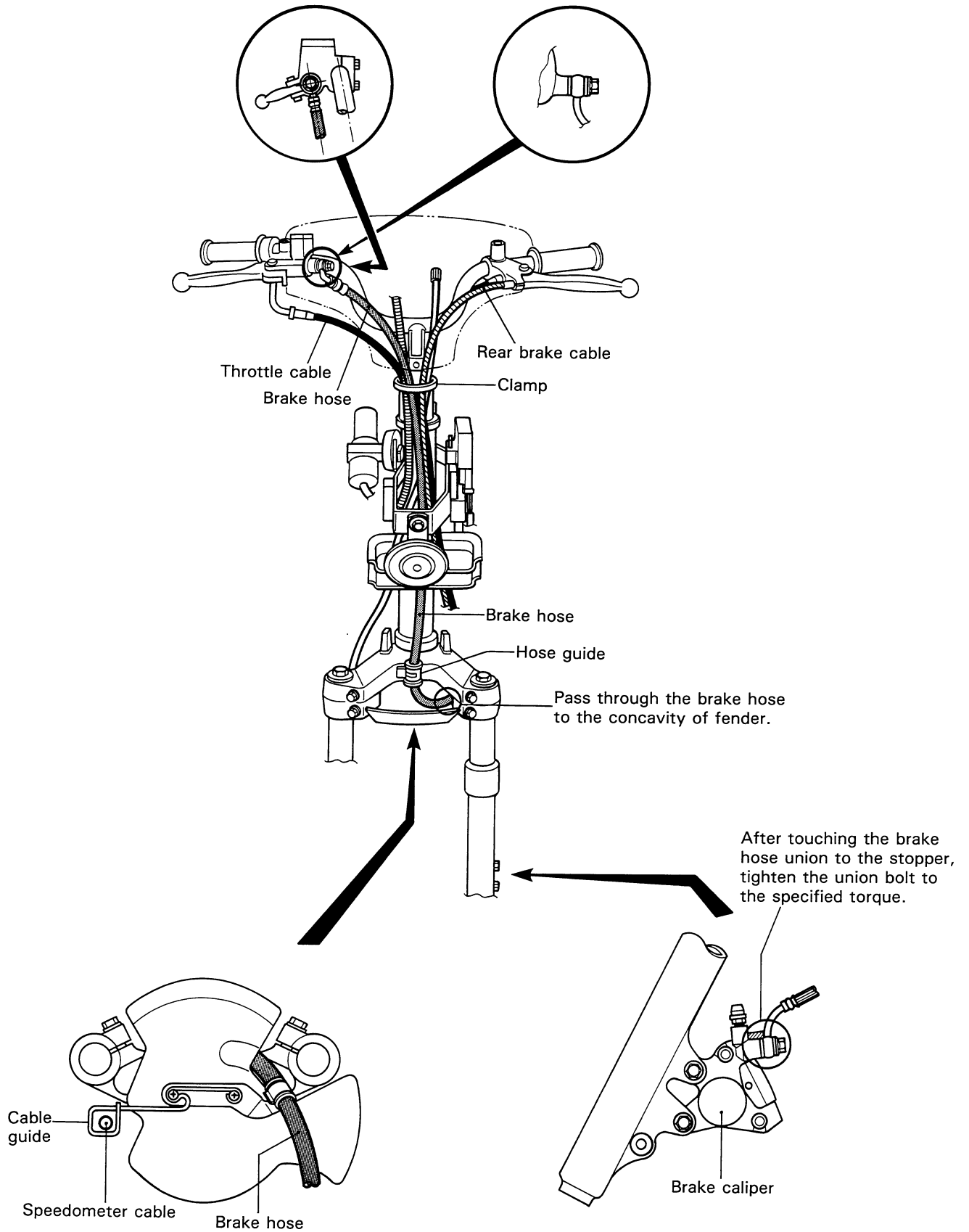

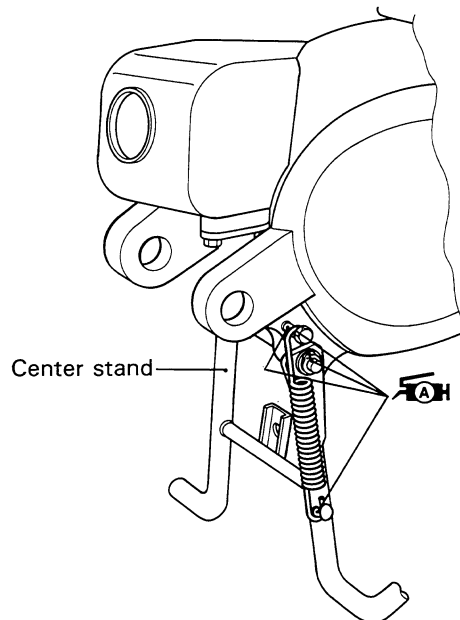
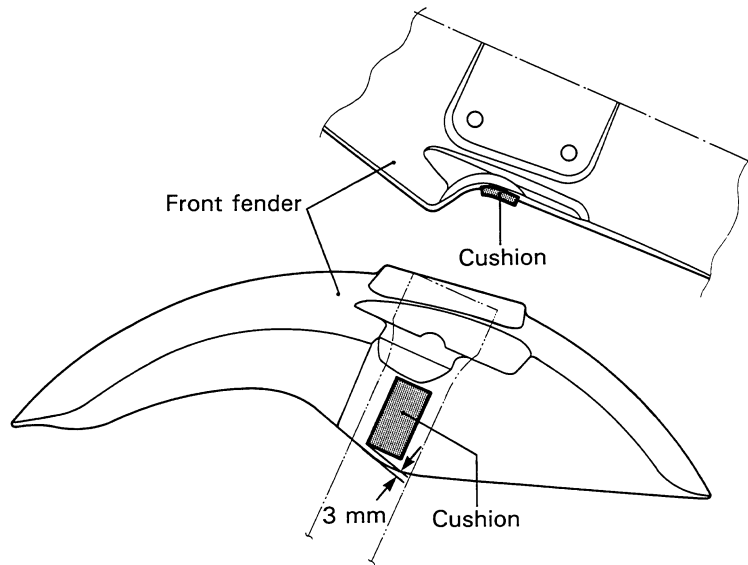
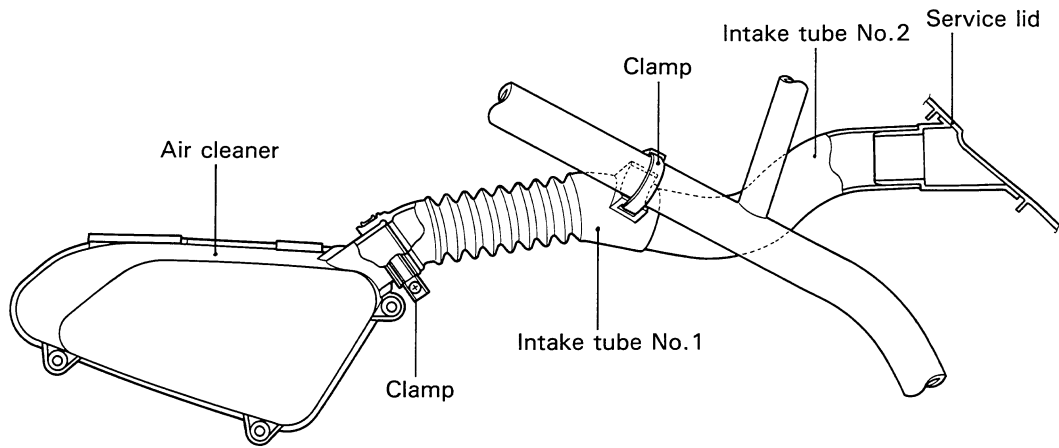

FRONT BRAKE HOSE ROUTING



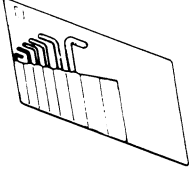
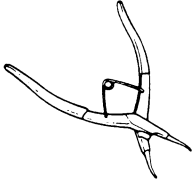
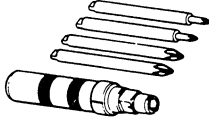
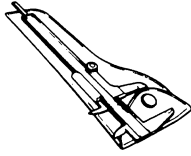
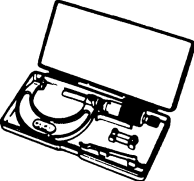

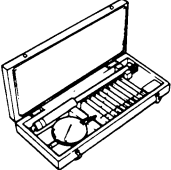

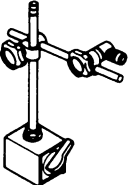
AIR CLEANER INTAKE HOSE, FRONT FENDER CUSHION AND CENTER STAND SET-UP

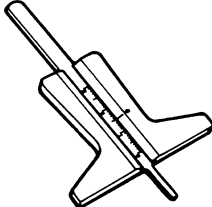
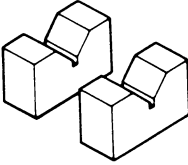
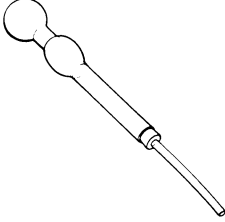
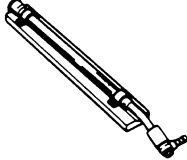
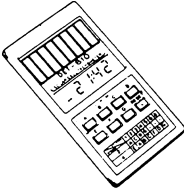
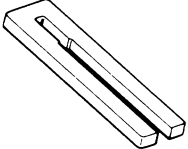
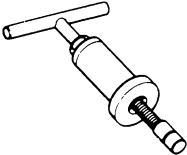
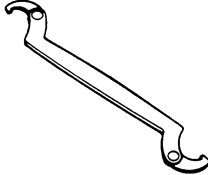
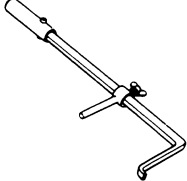
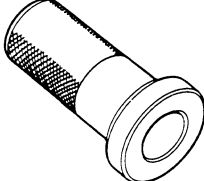

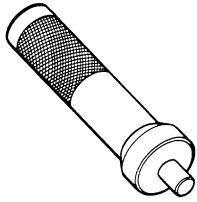
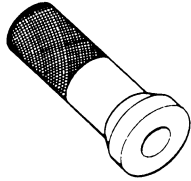
SPECIAL TOOLS

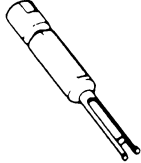
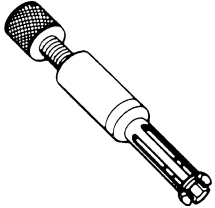
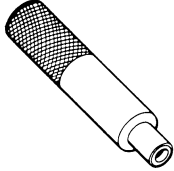
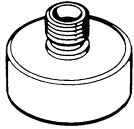
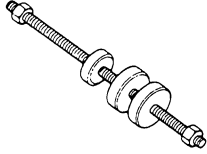
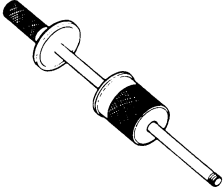
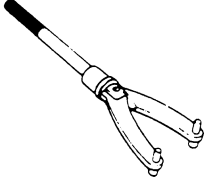
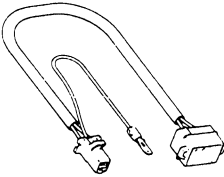
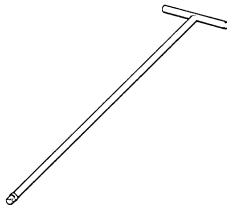
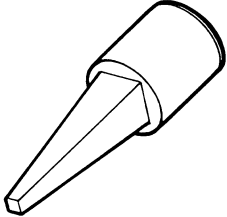
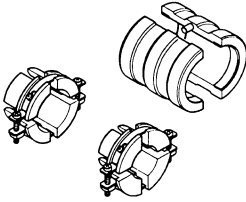
 <p>09900-00401 Hexagon wrench set</p>	 <p>09900-06107 Snap ring pliers</p>	 <p>09900-06108 Snap ring pliers</p>	 <p>09900-09003 Impact driver set</p>	 <p>09900-20101 Vernier calipers (150 mm)</p>
 <p>09900-20202 Micrometer (25–50 mm)</p>	 <p>09900-20205 Micrometer (0–25 mm)</p>	 <p>09900-20508 Cylinder bore gauge set</p>	 <p>09900-20605 Dial calipers</p>	 <p>09900-20606 Dial gauge (1/100 mm)</p>
 <p>09900-20701 Magnetic stand</p>	 <p>09900-20803 Thickness gauge</p>	 <p>09900-20804 Thickness gauge</p>	 <p>09900-20805 Tire depth gauge</p>	 <p>09900-21304 V-block (100 mm)</p>
 <p>09900-28403 Hydrometer</p>	 <p>09900-21602 CCI oil gauge</p>	 <p>09900-25002 Pocket tester</p>	 <p>09900-26006 Tachometer</p>	 <p>09900-28106 Electro tester</p>
 <p>09910-20115 09910-20116 Conrod holder</p>	 <p>09910-32812 Crankshaft installer</p>	 <p>09910-60611 Universal clamp wrench</p>	 <p>09913-50121 Oil seal remover</p>	 <p>09913-75810 Bearing remover/ installer</p>

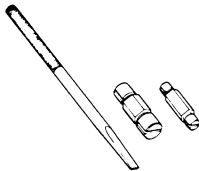
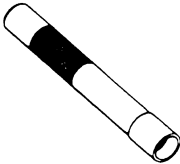
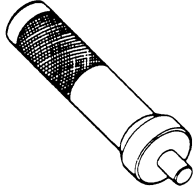
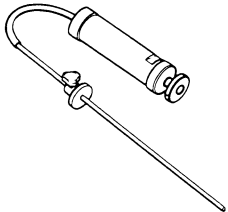
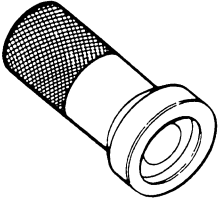
 <p>09913-75821 Bearing remover/ installer</p>	 <p>09913-76010 Bearing installer</p>	 <p>09920-13120 Crankcase separating tool</p>	 <p>09921-20210 Bearing remover</p>	 <p>09923-73210 Bearing remover</p>
 <p>09924-74510 Oil seal installer handle</p>	 <p>09924-74540 Oil seal installer attachment</p>	 <p>09924-84521 Bearing installer set</p>	 <p>09930-30102 Sliding shaft</p>	 <p>09930-40113 Rotor holder</p>
 <p>09930-81010 Ignition coil test lead</p>	 <p>09940-34520 "T" handle</p>	 <p>09940-34561 Attachment "D"</p>	 <p>09940-52860 Front fork oil seal installer</p>	 <p>09941-34513 Bearing installer</p>
 <p>09941-50111 Bearing remover</p>	 <p>09941-74910 Bearing installer</p>	 <p>09943-88211 Bearing remover/ installer</p>	 <p>09943-74111 Front fork oil level gauge</p>	 <p>09951-16080 Bearing installer</p>

TIGHTENING TORQUE**ENGINE**

ITEM	N·m	kg-m	lb-ft
Cylinder head nut	10	1.0	7.0
Spark plug	28	2.8	20.0
Exhaust pipe bolt and nut	10	1.0	7.0
Engine mounting bracket nut	60	6.0	43.5
Engine mounting nut	60	6.0	43.5
Muffler mounting bolt	23	2.3	16.5
Clutch housing nut	50	5.0	36.0
Kick starter nut	50	5.0	36.0
Magneto rotor nut	40	4.0	29.0
Clutch shoe nut	50	5.0	36.0
Kick starter lever bolt	10	1.0	7.0
Final gear oil drain bolt	6	0.6	4.5
Final gear oil level bolt	12	1.2	8.5
Oil pump mounting screw	4	0.4	3.0

CHASSIS

ITEM	N·m	kg-m	lb-ft
Steering stem lock nut	80	8.0	58.0
Handlebars clamp nut	49	4.9	35.5
Handlebars set bolt	25	2.5	18.0
Front fork clamp bolt	23	2.3	16.5
Front fork damper rod bolt	20	2.0	14.5
Front brake caliper mounting bolt	26	2.6	19.0
Front brake hose union bolt	23	2.3	16.5
Front brake caliper air bleeder valve	8	0.8	6.0
Front brake caliper housing bolt	25	2.5	18.0
Front brake disc bolt	23	2.3	16.5
Front brake master cylinder bolt	10	1.0	7.0
Front axle nut	42	4.2	30.5
Rear axle nut	75	7.5	54.0
Rear shock absorber bolt (Upper)	29	2.9	21.0
Rear shock absorber nut	32	3.2	23.0
Rear brake cam lever nut	7	0.7	5.0

TIGHTENING TORQUE CHART

For other bolts and nuts listed in the preceding page, refer to this chart:

Bolt Diameter Ⓐ (mm)	Conventional or "4" marked bolt			"7" marked bolt		
	N·m	kg-m	lb-ft	N·m	kg-m	lb-ft
4	1.5	0.15	1.0	2.3	0.23	1.5
5	3	0.3	2.0	4.5	0.45	3.0
6	5.5	0.55	4.0	10	1.0	7.0
8	13	1.3	9.5	23	2.3	16.5
10	29	2.9	21.0	50	5.0	36.0
12	45	4.5	32.5	85	8.5	61.5
14	65	6.5	47.0	135	13.5	97.5
16	105	10.5	76.0	210	21.0	152.0
18	160	16.0	115.5	240	24.0	173.5

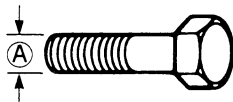

Conventional bolt

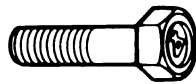

"4" marked bolt

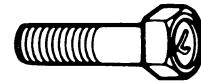

"7" marked bolt

SERVICE DATA**CYLINDER + PISTON + PISTON RING**

Unit: mm (in)

ITEM	STANDARD			LIMIT
Piston to cylinder clearance	0.06–0.07 (0.0024–0.0028)			0.120 (0.0047)
Cylinder bore	41.005–41.020 (1.6144–1.6150) Measure at 20 (0.8) from the top surface			41.075 (1.6171)
Piston diam.	40.940–40.955 (1.6118–1.6124) Measure at 15 (0.6) from the skirt end			40.885 (1.6096)
Cylinder distortion	—			0.05 (0.002)
Cylinder head distortion	—			0.05 (0.002)
Piston ring free end gap	1st	R	Approx. 4.0 (0.16)	3.2 (0.126)
	2nd	R	Approx. 4.3 (0.17)	3.4 (0.134)
Piston ring end gap	1st & 2nd	R	0.10–0.25 (0.004–0.010)	0.80 (0.031)
Piston ring to groove clearance	1st		0.020–0.060 (0.0008–0.0024)	—
	2nd		0.020–0.060 (0.0008–0.0024)	—
Piston pin bore	10.002–10.010 (0.3938–0.3941)			10.030 (0.3949)
Piston pin O.D.	9.995–10.000 (0.3935–0.3937)			9.980 (0.3929)

CONROD + CRANKSHAFT

Unit: mm (in)

ITEM	STANDARD	LIMIT
Conrod small end I.D.	14.003–14.011 (0.5513–0.5516)	14.040 (0.5528)
Conrod deflection	—	3.0 (0.12)
Crank web to web width	35.0±0.1 (1.378±0.004)	—
Crankshaft runout	—	0.05 (0.002)

OIL PUMP

ITEM	SPECIFICATION
Oil pump reduction ratio	30.000 (30/1)
Oil pump discharge rate	0.9–1.1 ml (0.03–0.04 Imp oz) for 5 minutes at 3 000 r/min.

CLUTCH

Unit: mm (in)

ITEM	STANDARD	LIMIT
Clutch wheel I.D.	110.00–110.15 (4.331–4.337)	110.50 (4.350)
Clutch shoe thickness	3.0 (0.12)	2.0 (0.08)
Clutch engagement	3 300 ± 200 r/min.	—
Clutch lock-up	4 500 ± 300 r/min.	—

TRANSMISSION

Unit: mm (in) Except ratio

ITEM	STANDARD	LIMIT
Reduction ratio	P-04 Variable 2.768–0.960	—
	The others Variable 2.817–0.866	—
Final reduction ratio	12.876 (38/11 x 41/11)	—
Drive belt width	16.9 (0.67)	16.0 (0.63)
Driven face spring free length	110 (4.3)	104.5 (4.11)

CARBURETOR

ITEM	SPECIFICATION		
	P-34,53	P-04	P-22
Carburetor type	MIKUNI VM12SH	MIKUNI VM14SH	←
Bore size	12 mm	14 mm	←
I.D. No.	09E0	09EC	09E2
Idle r/min.	1 700 ± 200 r/min.	←	←
Float height	17.2 ± 1.0 mm (0.68 ± 0.04 in)	←	←
Main jet (M.J.)	# 55	←	←
Main air jet (M.A.J.)	0.7 mm	←	←
Jet needle (J.N.)	3L38-3rd	3L30-4th	3L36-2nd
Needle jet (N.J.)	E-3	E-0	←
Valve seat (V.S.)	1.2 mm	←	←
Pilot jet (P.J.)	# 20	# 17.5	←
Starter jet (G.S.)	# 25	←	←
Throttle cable play	3–6 mm (0.1–0.2 in)	←	←

ELECTRICAL

Unit: mm (in)

ITEM	SPECIFICATION	NOTE
Ignition timing	18° B.T.D.C. at 4 000 r/min.	
Spark plug	Type NGK: BPR6HS ND: W20FPR-U BOSCH: WR7BC	
	Gap 0.6–0.7 (0.024–0.028)	
Spark performance	Over 8 (0.3) at 1 atm.	
Ignition coil resistance	Secondary 14–30 kΩ	Plug cap— Small terminal
Magneto coil resistance	Lighting 0.3–1.0 Ω	Y/W—Ground
	Charging 0.5–1.2 Ω	W/R—Ground
	Exciting 170–270 Ω	B/R—Ground

7-25 SERVICING INFORMATION

ITEM		SPECIFICATION	NOTE
Generator no-load voltage		More than 25V (AC) at 5 000 r/min.	W/R—Ground
Regulated voltage		13.0—15.0 V at 5 000 r/min.	
Starter relay resistance		50—90 Ω	
Battery	Type designation	FB4L-B	P-53
		YT4L-BS	The others
	Capacity	12 V 14.4 kC (4 Ah)/10 HR	P-53
		12 V 10.8 kC (3 Ah)/10 HR	The others
Standard electrolyte S.G.	1.280 at 20°C (68°F)	P-53	
	1.320 at 20°C (68°F)	The others	
Fuse size		10 A	

WATTAGE

Unit: W

ITEM		SPECIFICATION			
		P-04	P-22	P-34	P-53
Headlight	HI	/	/	/	25
	LO	15 × 2	←	←	25
Position light		/	5	←	/
Tail/Brake light		5/21	←	←	←
Turn signal light		10	←	←	←
Speedometer light		1.2 × 2	←	←	←
Turn signal indicator light		2	←	←	←
Oil level indicator light		2	←	←	←
High beam indicator light		/	/	/	1.2
Trunk light		2	←	←	←

BRAKE + WHEEL

Unit: mm (in)

ITEM		STANDARD	LIMIT
Brake lever play	Rear	15—25 (0.6—1.0)	—
Brake drum I.D.	Rear	—	120.7 (4.75)
Brake lining thickness	Rear	—	1.5 (0.06)
Brake disc thickness	Front	4.0 ± 0.2 (0.157 ± 0.008)	3.5 (0.14)
Brake disc runout	Front	—	0.30 (0.012)
Master cylinder bore	Front	11.000—11.043 (0.4331—0.4348)	—
Master cylinder piston diam.	Front	10.957—10.984 (0.4314—0.4324)	—
Brake caliper cylinder bore	Front	30.230—30.306 (1.1902—1.1931)	—
Brake caliper piston diam.	Front	30.150—30.200 (1.1870—1.1890)	—
Wheel rim runout	Axial	—	2.0 (0.08)
	Radial	—	2.0 (0.08)

ITEM	STANDARD		LIMIT
Wheel axle runout	Front	—	0.25 (0.010)
Tire size	Front	90/90-10 (P53)	
		100/80-10 (The others)	
	Rear	90/90-10 (P-53)	
		100/80-10 (The others)	
Tire tread depth	Front	—	1.6 (0.06)
	Rear	—	1.6 (0.06)

SUSPENSION

Unit: mm (in)

ITEM	STANDARD	LIMIT	NOTE
Front fork stroke	72 (2.8)	—	
Front fork spring free length	—	237.1 (9.3)	
Front fork oil level	64 (2.5)	—	
Rear wheel travel	63 (2.5)	—	

TIRE PRESSURE

P-34, 53

COLD INFLATION TIRE PRESSURE	SOLO RIDING		
	kPa	kg/cm ²	psi
FRONT	125	1.25	18
REAR	175	1.75	25

P-04, 22

COLD INFLATION TIRE PRESSURE	SOLO RIDING			DUAL RIDING		
	kPa	kg/cm ²	psi	kPa	kg/cm ²	psi
FRONT	125	1.25	18	125	1.25	18
REAR	175	1.75	25	250	2.50	36

FUEL + OIL

ITEM	SPECIFICATION	NOTE
Fuel type	Gasoline used should be graded 85-95 octane or higher. An unleaded gasoline is recommended.	
Fuel tank capacity	5.0 L (1.3/1.1 US/Imp gal)	
Engine oil type	CCI SUPER OIL	
Engine oil tank capacity	0.8 L (0.8/0.7 US/Imp qt)	
Final gear oil type	SAE 10W/40	
Final gear oil capacity	90 ml (3.0/3.2 US/Imp oz)	
Front fork oil type	Fork oil # 10	
Front fork oil capacity (each leg)	96 ml (3.2/3.4 US/Imp oz)	
Brake fluid type	DOT 4	

AP50T ('96-MODEL)

CONTENTS

<i>SPECIFICATIONS</i>	<i>8- 1</i>
<i>SERVICE DATA</i>	<i>8- 2</i>
<i>WIRING DIAGRAM</i>	<i>8- 6</i>
<i>FUEL HOSE ROUTING</i>	<i>8- 8</i>

SPECIFICATIONS

DIMENSIONS AND DRY MASS

Overall length	1 715 mm (67.5 in)
Overall width	660 mm (26.0 in)
Overall height	1 065 mm (41.9 in)
Wheelbase	1 195 mm (47.0 in)
Ground clearance	125 mm (4.9 in)
Dry mass	76 kg (168 lbs)

ENGINE

Type	Two-stroke, forced air-cooled
Intake system	Reed valve
Number of cylinder	1
Bore	41.0 mm (1.614 in)
Stroke	37.4 mm (1.472 in)
Piston displacement	49 cm ³ (3.0 cu. in)
Corrected compression ratio	6.7 : 1 ... P-22 7.4 : 1 ... The others
Carburetor	MIKUNI VM12SH, single ... P-34 MIKUNI VM14SH, single ... The others
Air cleaner	Polyurethane foam element
Starter system	Electric and kick
Lubrication system	SUZUKI "CCI"

TRANSMISSION

Clutch	Dry shoe, automatic, centrifugal type
Gearshifting	Automatic, variable ratio
Gear ratios, variable	Variable reduction ratio (2.768—0.960) ... P-04 Variable reduction ratio (2.817—0.866) ... The others
Final reduction ratio ...	12.876 (38/11) × (41/11)
Drive system	V-belt drive

CHASSIS

Front suspension	Telescopic, coil spring, oil damped
Rear suspension	Swingarm type, coil spring, oil damped
Steering angle	45° (right & left)
Caster	65°
Trail	66 mm (2.6 in)
Turning radius	1.7 m (5.6 ft)
Front brake	Disc brake
Rear brake	Internal expanding
Front tire size	100/80-10
Rear tire size	100/80-10

ELECTRICAL

Ignition type	Electronic ignition (CDI)
Ignition timing	18° B.T.D.C. at 4 000 r/min
Spark plug	NGK BPR6HS, ND W20FPR or BOSCH WR7BC
Battery	12V 14.4 kC (4Ah)/10HR ... P-53 12V 10.8 kC (3Ah)/10HR ... The others
Generator	Magneto
Fuse	10A
Headlight	12V 25/25W ... P-02,26,53 12V 15W × 2 ... The others
Tail/Brake light	12V 5/21W
Turn signal light	12V 10W

CAPACITIES

Fuel tank	5.0 L (1.3/1.1 US/Imp gal)
Engine oil tank	0.8 L (0.8/0.7 US/Imp qt)
Final gear oil	90 ml (3.0/3.2 US/Imp oz)
Front fork oil	96 ml (3.2/3.4 US/Imp oz)

* These specifications are subject to change without notice.

SERVICE DATA**CYLINDER + PISTON + PISTON RING**

Unit: mm (in)

ITEM	STANDARD			LIMIT
Piston to cylinder clearance	0.06–0.07 (0.0024–0.0028)			0.120 (0.0047)
Cylinder bore	41.005–41.020 (1.6144–1.6150) Measure at 20 (0.8) from the top surface			41.075 (1.6171)
Piston diam.	40.940–40.955 (1.6118–1.6124) Measure at 15 (0.6) from the skirt end			40.885 (1.6096)
Cylinder distortion	—			0.05 (0.002)
Cylinder head distortion	—			0.05 (0.002)
Piston ring free end gap	1st	R	Approx. 4.0 (0.16)	3.2 (0.126)
	2nd	R	Approx. 4.3 (0.17)	3.4 (0.134)
Piston ring end gap	1st & 2nd	R	0.10–0.25 (0.004–0.010)	0.80 (0.031)
Piston ring to groove clearance	1st		0.020–0.060 (0.0008–0.0024)	—
	2nd		0.020–0.060 (0.0008–0.0024)	—
Piston pin bore	10.002–10.010 (0.3938–0.3941)			10.030 (0.3949)
Piston pin O.D.	9.995–10.000 (0.3935–0.3937)			9.980 (0.3929)

CONROD + CRANKSHAFT

Unit: mm (in)

ITEM	STANDARD	LIMIT
Conrod small end I.D.	14.003–14.011 (0.5513–0.5516)	14.040 (0.5528)
Conrod deflection	—	3.0 (0.12)
Crank web to web width	35.0±0.1 (1.378±0.004)	—
Crankshaft runout	—	0.05 (0.002)

OIL PUMP

ITEM	SPECIFICATION
Oil pump reduction ratio	30.000 (30/1)
Oil pump discharge rate	0.9–1.1 ml (0.03–0.04 Imp oz) for 5 minutes at 3 000 r/min.

CLUTCH

Unit: mm (in)

ITEM	STANDARD	LIMIT
Clutch wheel I.D.	110.00–110.15 (4.331–4.337)	110.50 (4.350)
Clutch shoe thickness	3.0 (0.12)	2.0 (0.08)
Clutch engagement	3 300 ± 200 r/min.	—
Clutch lock-up	4 500 ± 300 r/min.	—

TRANSMISSION

Unit: mm (in) Except ratio

ITEM	STANDARD	LIMIT
Reduction ratio	P-04 Variable 2.768–0.960	—
	The others Variable 2.817–0.866	—
Final reduction ratio	12.876 (38/11 x 41/11)	—
Drive belt width	16.9 (0.67)	16.0 (0.63)
Driven face spring free length	69.8 (2.75)	66.3 (2.61)

CARBURETOR

ITEM	SPECIFICATION		
	P-02	P-04	P-22
Carburetor type	MIKUNI VM14SH	←	←
Bore size	14 mm	←	←
I.D. No.	09E3	09EC	09E2
Idle r/min.	1 700 ± 200 r/min.	←	←
Float height	17.2 ± 1.0 mm (0.68 ± 0.04 in)	←	←
Main jet (M.J.)	# 55	←	←
Jet needle (J.N.)	3L36-2nd	3L30-4th	3L36-2nd
Needle jet (N.J.)	E-0	←	←
Pilot jet (P.J.)	# 17.5	←	←
Starter jet (G.S.)	# 25	←	←
Throttle cable play	3–6 mm (0.1–0.2 in)	←	←

CARBURETOR

ITEM	SPECIFICATION	
	P-26, 53	P-34
Carburetor type	MIKUNI VM14SH	MIKUNI VM12SH
Bore size	14 mm	12 mm
I.D. No.	09ED	09E0
Idle r/min.	1 700 ± 200 r/min.	←
Float height	17.2 ± 1.0 mm (0.68 ± 0.04 in)	←
Main jet (M.J.)	# 57.5	# 55
Jet needle (J.N.)	3L30-2nd	3L38-3rd
Needle jet (N.J.)	E-3	←
Pilot jet (P.J.)	# 20	←
Starter jet (G.S.)	# 25	←
Throttle cable play	3–6 mm (0.1–0.2 in)	←

ELECTRICAL

Unit: mm (in)

ITEM		SPECIFICATION		NOTE
Ignition timing		18° B.T.D.C. at 4 000 r/min.		
Spark plug		Type	NGK: BPR6HS ND: W20FPR-U BOSCH: WR7BC	
		Gap	0.7–0.8 (0.028–0.031)	
Spark performance		Over 8 (0.3) at 1 atm.		
Ignition coil resistance		Secondary	14–30 kΩ	Plug cap— Small terminal
Magneto coil resistance		Lighting	0.3–1.0 Ω	Y/W—Ground
		Charging	0.5–1.2 Ω	W/R—Ground
		Exciting	170–270 Ω	B/R—Ground
Generator no-load voltage		More than 25V (AC) at 5 000 r/min.		W/R—Ground
Regulated voltage		13.0–15.0 V at 5 000 r/min.		
Magneto Max. output		90 W at 5 000 r/min.		
Starter relay resistance		50–90 Ω		
Battery	Type designation	FB4L-B		P-53
		YT4L-BS		The others
	Capacity	12 V 14.4 kC (4 Ah)/10 HR		P-53
		12 V 10.8 kC (3 Ah)/10 HR		The others
	Standard electrolyte S.G.	1.280 at 20°C (68°F)		P-53
1.320 at 20°C (68°F)		The others		
Fuse size		10 A		

WATTAGE

Unit: W

ITEM		SPECIFICATION			
		P-04	P-22, 34	P-02	P-26, 53
Headlight	HI	/	/	25	←
	LO	15 × 2	←	25	←
Position light		/	5	←	/
Tail/Brake light		5/21	←	←	←
Turn signal light		10	←	←	←
Speedometer light		1.2 × 2	←	←	←
Turn signal indicator light		2	←	←	←
Oil level indicator light		2	←	←	←
High beam indicator light		/	/	1.2	←
Trunk light		2	←	←	←

BRAKE + WHEEL

Unit: mm (in)

ITEM		STANDARD	LIMIT
Brake lever play	Rear	15–25 (0.6–1.0)	—
Brake drum I.D.	Rear	—	120.7 (4.75)
Brake lining thickness	Rear	—	1.5 (0.06)
Brake disc thickness	Front	4.0 ± 0.2 (0.157 ± 0.008)	3.5 (0.14)
Brake disc runout	Front	—	0.30 (0.012)
Master cylinder bore	Front	11.000–11.043 (0.4331–0.4348)	—
Master cylinder piston diam.	Front	10.957–10.984 (0.4314–0.4324)	—
Brake caliper cylinder bore	Front	30.230–30.306 (1.1902–1.1931)	—
Brake caliper piston diam.	Front	30.150–30.200 (1.1870–1.1890)	—
Wheel rim runout	Axial	—	2.0 (0.08)
	Radial	—	2.0 (0.08)
Wheel axle runout	Front	—	0.25 (0.010)
Wheel rim size	Front	J10 × MT2.50	—
	Rear	J10 × MT2.50	—
Tire size	Front	100/80-10	
	Rear	100/80-10	
Tire tread depth	Front	—	1.6 (0.06)
	Rear	—	1.6 (0.06)

SUSPENSION

Unit: mm (in)

ITEM	STANDARD	LIMIT	NOTE
Front fork stroke	72 (2.8)	—	
Front fork spring free length	—	237.1 (9.3)	
Front fork oil level	64 (2.5)	—	
Rear wheel travel	63 (2.5)	—	

TIRE PRESSURE

P-26, 34, 53

COLD INFLATION TIRE PRESSURE	SOLO RIDING		
	kPa	kg/cm ²	psi
FRONT	125	1.25	18
REAR	175	1.75	25

P-02, 04, 22

COLD INFLATION TIRE PRESSURE	SOLO RIDING			DUAL RIDING		
	kPa	kg/cm ²	psi	kPa	kg/cm ²	psi
FRONT	125	1.25	18	125	1.25	18
REAR	175	1.75	25	250	2.50	36

FUEL + OIL

ITEM	SPECIFICATION	NOTE
Fuel type	Gasoline used should be graded 85-95 octane or higher. An unleaded gasoline is recommended.	
Fuel tank capacity	5.0 L (1.3/1.1 US/Imp gal)	
Engine oil type	CCI SUPER OIL	
Engine oil tank capacity	0.8 L (0.8/0.7 US/Imp qt)	
Final gear oil type	SAE 10W/40	
Final gear oil capacity	90 ml (3.0/3.2 US/Imp oz)	
Front fork oil type	Fork oil # 10	
Front fork oil capacity (each leg)	96 ml (3.2/3.4 US/Imp oz)	
Brake fluid type	DOT 4	

WIRING DIAGRAM

For U.K.

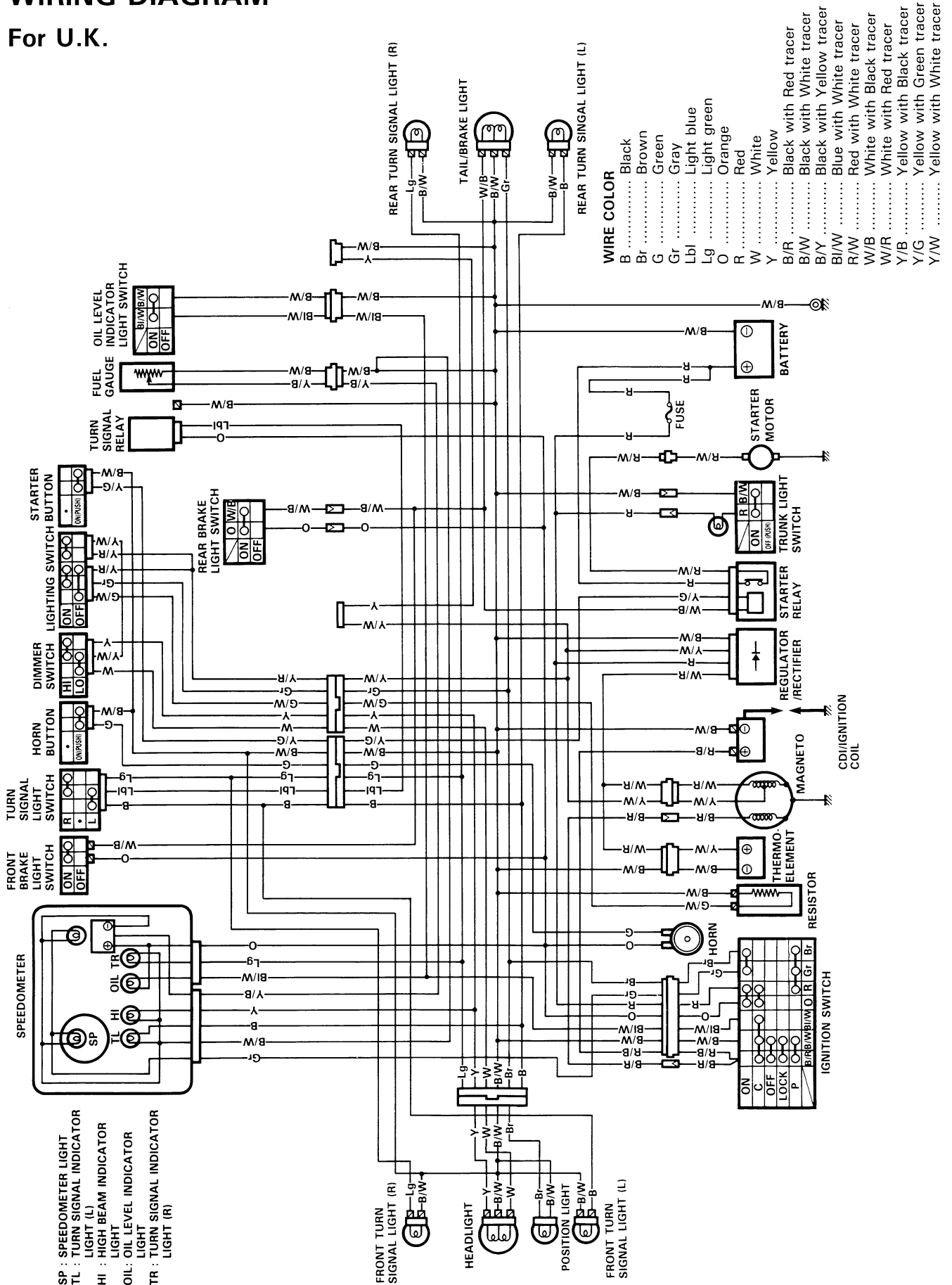

For Denmark and Spain

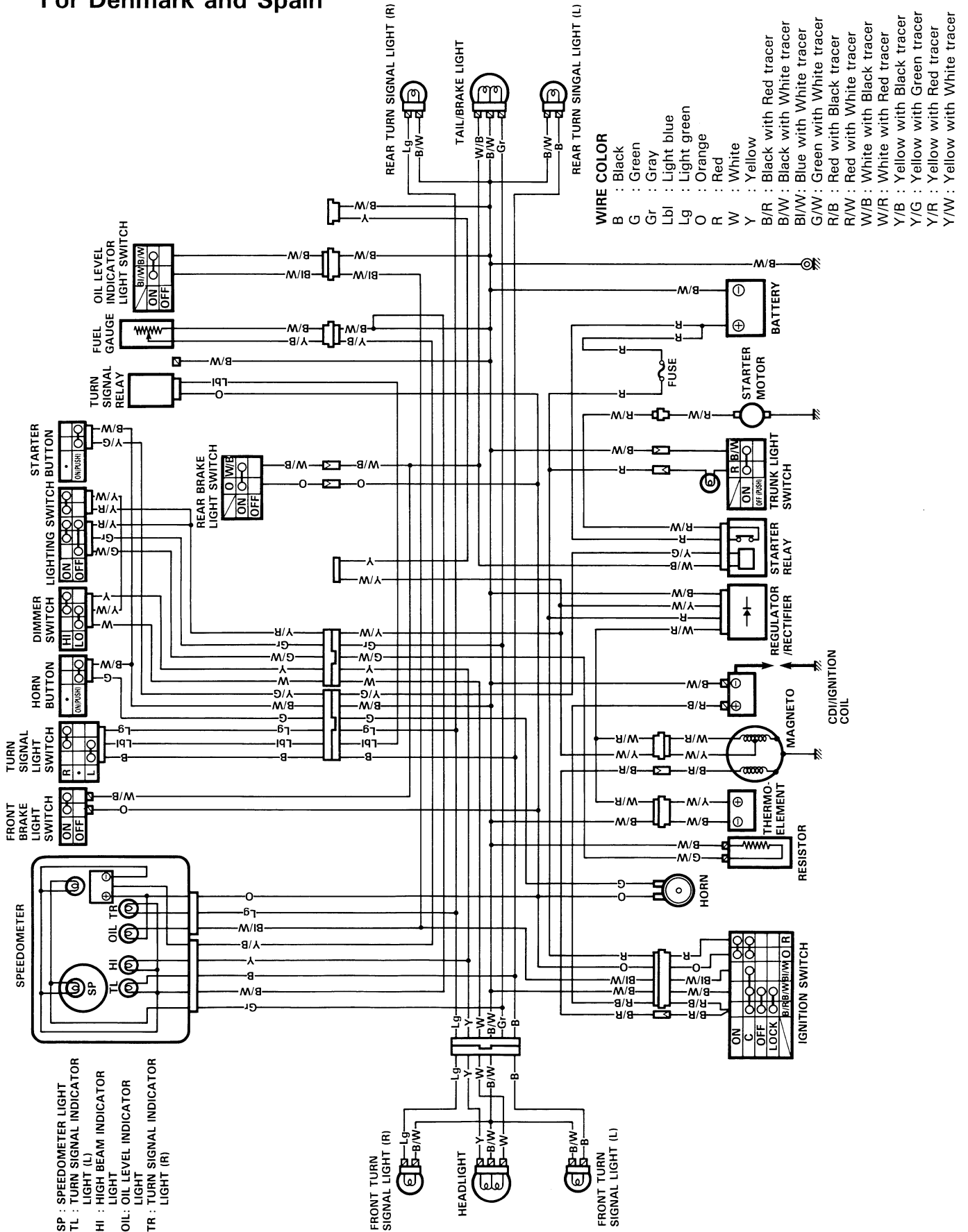

FUEL HOSE ROUTING

For France

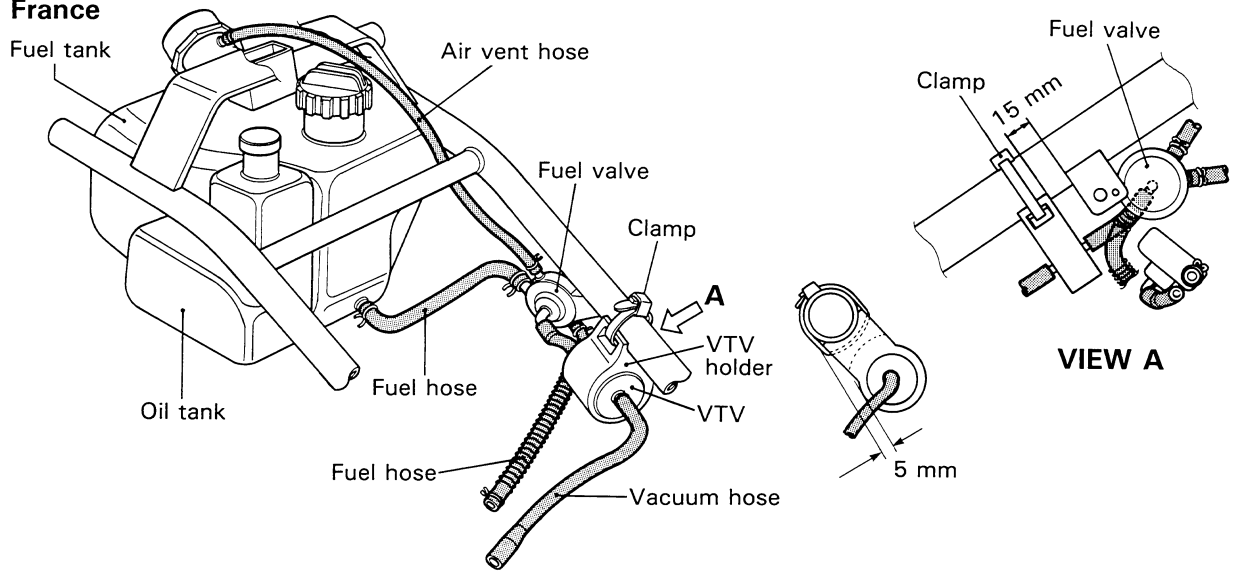

For Denmark, Spain and U.K.

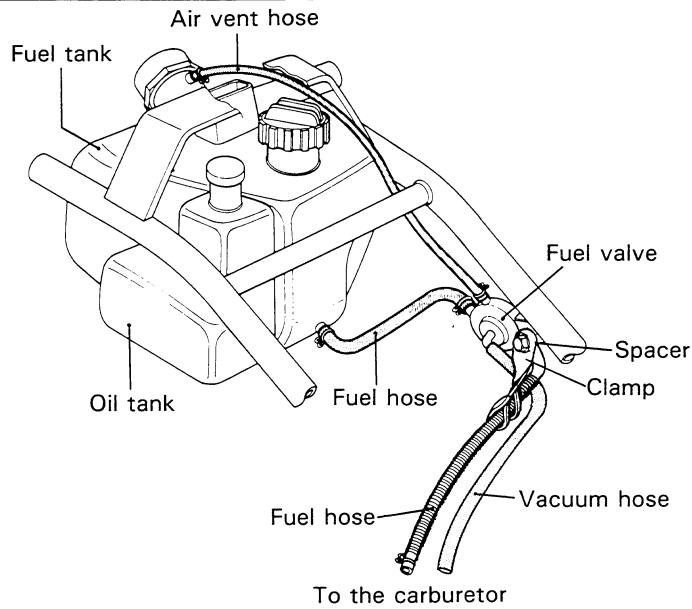

For the others

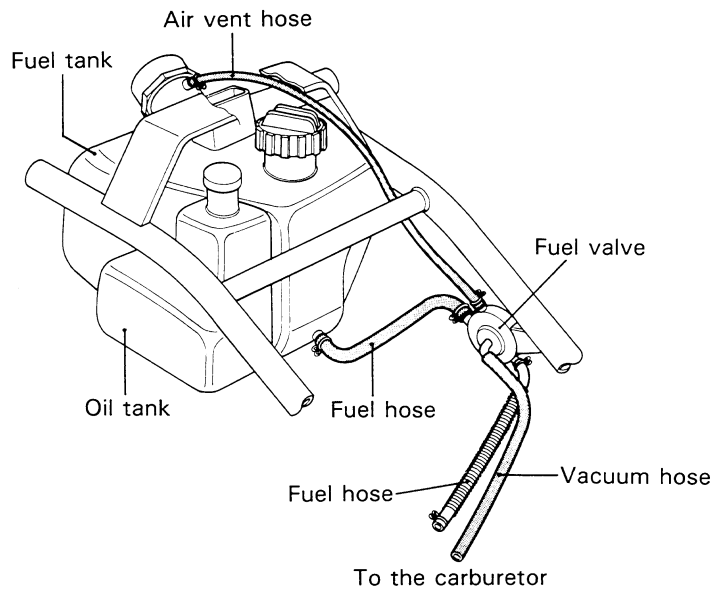

AP50V ('97-MODEL)

FOREWORD

This chapter describes service data and servicing procedures which differ from those of the AP50T ('96-MODEL).

NOTE:

- * *Any differences between AP50T ('96-MODEL) and AP50V ('97-MODEL) in specifications and service data are clearly indicated with the asterisk marks (*).*
- * *Please refer to the chapters 1 through 8 for details which are not given in this chapter.*

CONTENTS

SPECIFICATIONS	9- 1
SERVICE DATA	9- 2
PERIODIC MAINTENANCE SCHEDULE	9- 7
GEAR BOX COVER AND TRANSMISSION	9- 8
WIRING DIAGRAM	9-11
CARBURETOR OVERFLOW HOSE ROUTING	9-14

COUNTRY OR AREA

P-02: U.K.	P-34: Italy
P-04: France	P-37: Brazil
P-22: Germany	P-53: Spain
P-26: Denmark	

SPECIFICATIONS

DIMENSIONS AND DRY MASS

Overall length	*1 820 mm (71.7 in)
Overall width	660 mm (26.0 in)
Overall height	*1 105 mm (43.5 in)
Wheelbase	*1 255 mm (49.4 in)
Ground clearance	*180 mm (7.1 in)
Dry mass	*78 kg (172 lbs)

ENGINE

Type	Two-stroke, forced air-cooled
Intake system	Reed valve
Number of cylinder	1
Bore	41.0 mm (1.614 in)
Stroke	37.4 mm (1.472 in)
Piston displacement	49 cm ³ (3.0 cu. in)
Corrected compression ratio	6.7 : 1 ... P-22 7.4 : 1 ... The others
Carburetor	MIKUNI VM12SH, single ... P-34 MIKUNI VM14SH, single ... The others
Air cleaner	Polyurethane foam element
Starter system	Electric and kick
Lubrication system	SUZUKI "CCI"

TRANSMISSION

Clutch	Dry shoe, automatic, centrifugal type
Gearshifting	Automatic, variable ratio
Gear ratios, variable	*Variable reduction ratio (2.768—0.871)
Final reduction ratio ...	*14.960 (51/15) × (66/15) ... P-02,04,22 *12.800 (51/15) × (64/17) ... P-26,34,37,53
Drive system	V-belt drive

CHASSIS

Front suspension	Telescopic, coil spring, oil damped
Rear suspension	Swingarm type, coil spring, oil damped
Steering angle	45° (right & left)
Caster	25°
Trail	*68 mm (2.7 in)
Turning radius	*1.8 m (5.9 ft)
Front brake	Disc brake
Rear brake	Internal expanding
Front tire size	*100/90-10
Rear tire size	*120/90-10

ELECTRICAL

Ignition type	Electronic ignition (CDI)
Ignition timing	18° B.T.D.C. at 4 000 r/min
Spark plug	NGK BPR6HS, ND W20FPR or BOSCH WR7BC
Battery	12V 14.4 kC (4Ah)/10HR ... P-53 12V 10.8 kC (3Ah)/10HR ... The others
Generator	Magneto
Fuse	10A
Headlight	12V 25/25W ... P-02,37 12V 15W × 2 ... The others
Brake light/Taillight	12V 21/5W
Turn signal light	12V 10W

CAPACITIES

Fuel tank	5.0 L (1.3/1.1 US/Imp gal)
Engine oil tank	0.8 L (0.8/0.7 US/Imp qt)
Final gear oil	*130 ml (4.4/4.6 US/Imp oz)
Front fork oil	96 ml (3.2/3.4 US/Imp oz)

* These specifications are subject to change without notice.

SERVICE DATA**CYLINDER + PISTON + PISTON RING**

Unit: mm (in)

ITEM	STANDARD			LIMIT
Piston to cylinder clearance	0.06–0.07 (0.0024–0.0028)			0.120 (0.0047)
Cylinder bore	41.005–41.020 (1.6144–1.6150) Measure at 20 (0.8) from the top surface			41.075 (1.6171)
Piston diam.	40.940–40.955 (1.6118–1.6124) Measure at 15 (0.6) from the skirt end			40.885 (1.6096)
Cylinder distortion	—			0.05 (0.002)
Cylinder head distortion	—			0.05 (0.002)
Piston ring free end gap	1st	R	Approx. 4.0 (0.16)	3.2 (0.126)
	2nd	R	Approx. 4.3 (0.17)	3.4 (0.134)
Piston ring end gap	1st & 2nd	R	0.10–0.25 (0.004–0.010)	0.80 (0.031)
Piston ring to groove clearance	1st		0.020–0.060 (0.0008–0.0024)	—
	2nd		0.020–0.060 (0.0008–0.0024)	—
Piston pin bore	10.002–10.010 (0.3938–0.3941)			10.030 (0.3949)
Piston pin O.D.	9.995–10.000 (0.3935–0.3937)			9.980 (0.3929)

CONROD + CRANKSHAFT

Unit: mm (in)

ITEM	STANDARD	LIMIT
Conrod small end I.D.	14.003–14.011 (0.5513–0.5516)	14.040 (0.5528)
Conrod deflection	—	3.0 (0.12)
Crank web to web width	35.0±0.1 (1.378±0.004)	—
Crankshaft runout	—	0.05 (0.002)

OIL PUMP

ITEM	SPECIFICATION
Oil pump reduction ratio	30.000 (30/1)
Oil pump discharge rate	0.9–1.1 ml (0.03–0.04 Imp oz) for 5 minutes at 3 000 r/min.

CLUTCH

Unit: mm (in)

ITEM	STANDARD	LIMIT
Clutch wheel I.D.	110.00–110.15 (4.331–4.337)	110.50 (4.350)
Clutch shoe thickness	3.0 (0.12)	2.0 (0.08)
Clutch engagement	3 300 ± 200 r/min.	—
Clutch lock-up	4 500 ± 300 r/min.	—

TRANSMISSION

Unit: mm (in) Except ratio

ITEM	STANDARD	LIMIT
Reduction ratio	*Variable 2.768–0.871	—
Final reduction ratio	P-02,04,22	*14.960 (51/15 × 66/15)
	The others	*12.800 (51/15 × 64/17)
Drive belt width	16.9 (0.67)	16.0 (0.63)
Driven face spring free length	69.8 (2.75)	66.3 (2.61)

CARBURETOR

ITEM	SPECIFICATION		
	P-02	P-04	P-22
Carburetor type	MIKUNI VM14SH	←	←
Bore size	14 mm	←	←
I.D. No.	*09EG	*09EH	*09EJ
Idle r/min.	1 700 ± 200 r/min.	*1 800 ± 200 r/min.	1 700 ± 200 r/min
Float height	17.2 ± 1.0 mm (0.68 ± 0.04 in)	←	←
Main jet (M.J.)	* # 57.5	# 55	* # 60
Jet needle (J.N.)	*3L30-2nd	3L30-4th	3L36-2nd
Needle jet (N.J.)	*E-3	E-0	←
Pilot jet (P.J.)	* # 20	# 17.5	←
Starter jet (G.S.)	# 25	←	←
Throttle cable play	3–6 mm (0.1–0.2 in)	←	←

CARBURETOR

ITEM	SPECIFICATION		
	P-26, 53	*P-37	P-34
Carburetor type	MIKUNI VM14SH	←	MIKUNI VM12SH
Bore size	14 mm	←	12 mm
I.D. No.	*09EF	09EL	*09EK
Idle r/min.	1 700 ± 200 r/min.	←	←
Float height	17.2 ± 1.0 mm (0.68 ± 0.04 in)	←	←
Main jet (M.J.)	# 57.5	←	# 55
Jet needle (J.N.)	3L30-2nd	←	3L38-3rd
Needle jet (N.J.)	E-3	←	←
Pilot jet (P.J.)	# 20	←	←
Starter jet (G.S.)	# 25	←	←
Throttle cable play	3–6 mm (0.1–0.2 in)	←	←

ELECTRICAL

Unit: mm (in)

ITEM		SPECIFICATION		NOTE
Ignition timing		18° B.T.D.C. at 4 000 r/min.		
Spark plug	Type	NGK: BPR6HS ND: W20FPR-U BOSCH: WR7BC		
	Gap	0.7–0.8 (0.028–0.031)		
Spark performance		Over 8 (0.3) at 1 atm.		
Ignition coil resistance		Secondary	14–30 kΩ	Plug cap— Small terminal
Magneto coil resistance	Lighting	0.3–1.0 Ω (Y/W—Ground)		P-02,04,22,34
	Charging	0.5–1.2 Ω (W/R—Ground)		
	Exciting	170–270 Ω (B/R—Ground)		
	Lighting	*0.5–2.5 Ω (Y/W—Ground)		P-26,37,53
	Charging	*1.0–3.0 Ω (W/R—Ground)		
	Exciting	*200–400 Ω (B/R—Ground)		
Generator no-load voltage		More than 25V (AC) at 5 000 r/min.		W/R—Ground
Regulated voltage		13.0–15.0 V at 5 000 r/min.		
Magneto Max. output		90 W at 5 000 r/min.		
Starter relay resistance		50–90 Ω		
Battery	Type designation	FB4L-B		P-53
		YT4L-BS		The others
	Capacity	12 V 14.4 kC (4 Ah)/10 HR		P-53
		12 V 10.8 kC (3 Ah)/10 HR		The others
	Standard electrolyte S.G.	1.280 at 20°C (68°F)		P-53
1.320 at 20°C (68°F)		The others		
Fuse size		10 A		

WATTAGE

Unit: W

ITEM		SPECIFICATION		
		P-04,22,26,34,53	P-02	*P-37
Headlight	HI		25	←
	LO	15 × 2	25	←
Position light			5	
Brake light/Taillight		21/5	←	←
Turn signal light		10	←	←
Speedometer light		1.2 × 2	←	←
Turn signal indicator light		2	←	←
Oil level indicator light		2	←	←
High beam indicator light			2	←
Trunk light		2	←	←

BRAKE + WHEEL

Unit: mm (in)

ITEM		STANDARD	LIMIT
Brake lever play	Rear	15–25 (0.6–1.0)	—
Brake drum I.D.	Rear	—	120.7 (4.75)
Brake lining thickness	Rear	—	1.5 (0.06)
Brake disc thickness	Front	4.0±0.2 (0.157±0.008)	3.5 (0.14)
Brake disc runout	Front	—	0.30 (0.012)
Master cylinder bore	Front	11.000–11.043 (0.4331–0.4348)	—
Master cylinder piston diam.	Front	10.957–10.984 (0.4314–0.4324)	—
Brake caliper cylinder bore	Front	30.230–30.306 (1.1902–1.1931)	—
Brake caliper piston diam.	Front	30.150–30.200 (1.1870–1.1890)	—
Wheel rim runout	Axial	—	2.0 (0.08)
	Radial	—	2.0 (0.08)
Wheel axle runout	Front	—	0.25 (0.010)
Wheel rim size	Front	J10×MT2.50	—
	Rear	J10×MT2.50	—
Tire size	Front	*100/90-10	—
	Rear	*120/90-10	—
Tire tread depth	Front	—	1.6 (0.06)
	Rear	—	1.6 (0.06)

SUSPENSION

Unit: mm (in)

ITEM	STANDARD	LIMIT	NOTE
Front fork stroke	72 (2.8)	—	
Front fork spring free length	—	*265 (10.4)	
Front fork oil level	*91 (3.6)	—	
Rear wheel travel	63 (2.5)	—	

TIRE PRESSURE

P-26, 34, 37, 53

COLD INFLATION TIRE PRESSURE	SOLO RIDING		
	kPa	kg/cm ²	psi
FRONT	125	1.25	18
REAR	175	1.75	25

P-02, 04, 22

COLD INFLATION TIRE PRESSURE	SOLO RIDING			DUAL RIDING		
	kPa	kg/cm ²	psi	kPa	kg/cm ²	psi
FRONT	125	1.25	18	125	1.25	18
REAR	175	1.75	25	250	2.50	36

FUEL + OIL

ITEM	SPECIFICATION	NOTE
Fuel type	Gasoline used should be graded 85-95 octane or higher. An unleaded gasoline is recommended.	
Fuel tank capacity	5.0 L (1.3/1.1 US/Imp gal)	
Engine oil type	Use SUZUKI CCI SUPER OIL. If they are not available, use a good quality 2-stroke oil rated FC under JASO classification.	
Engine oil tank capacity	0.8 L (0.8/0.7 US/Imp qt)	
Final gear oil type	SAE 10W/40	
Final gear oil capacity	* 130 ml (4.4/4.6 US/Imp oz)	
Front fork oil type	Fork oil # 10	
Front fork oil capacity (each leg)	96 ml (3.2/3.4 US/Imp oz)	
Brake fluid type	DOT 4	

PERIODIC MAINTENANCE SCHEDULE

The chart below lists the recommended intervals for all the required periodic service work necessary to keep the motorcycle operating at peak performance and economy. Mileages are expressed in terms of kilometers and time for your convenience.

NOTE:

More frequent servicing may be performed on motorcycles that are used under severe conditions.

PERIODIC MAINTENANCE CHART

INTERVAL: This interval should be judged by odometer reading or month which comes first.	km	Initial 1 000	Every 3 000	Every 6 000
	months	2	6	12
Battery (Specific gravity of electrolyte) ... P-53	—	I	I	I
Air cleaner	—	C	C	C
Cylinder head and cylinder	—	C	C	C
Spark plug	—	C	R	R
Carburetor	I	I	I	I
Fuel line	—	I	I	I
	Replace every 4 years			
Final gear oil	I	—	I	I
Brakes	I	I	I	I
Brake hose	—	I	I	I
	Replace every 4 years			
Brake fluid	—	I	I	I
	Replace every 2 years			
Steering	I	I	I	I
Front fork	—	—	I	I
Rear suspension	—	—	I	I
Tires	—	I	I	I
Cylinder head nuts and exhaust pipe bolt and nut	T	T	T	T
Chassis bolts and nuts	T	T	T	T

NOTE:

I: Inspection and adjust, clean, lubricate or replace as necessary

C: Clean R: Replace T: Tighten

GEAR BOX COVER AND TRANSMISSION

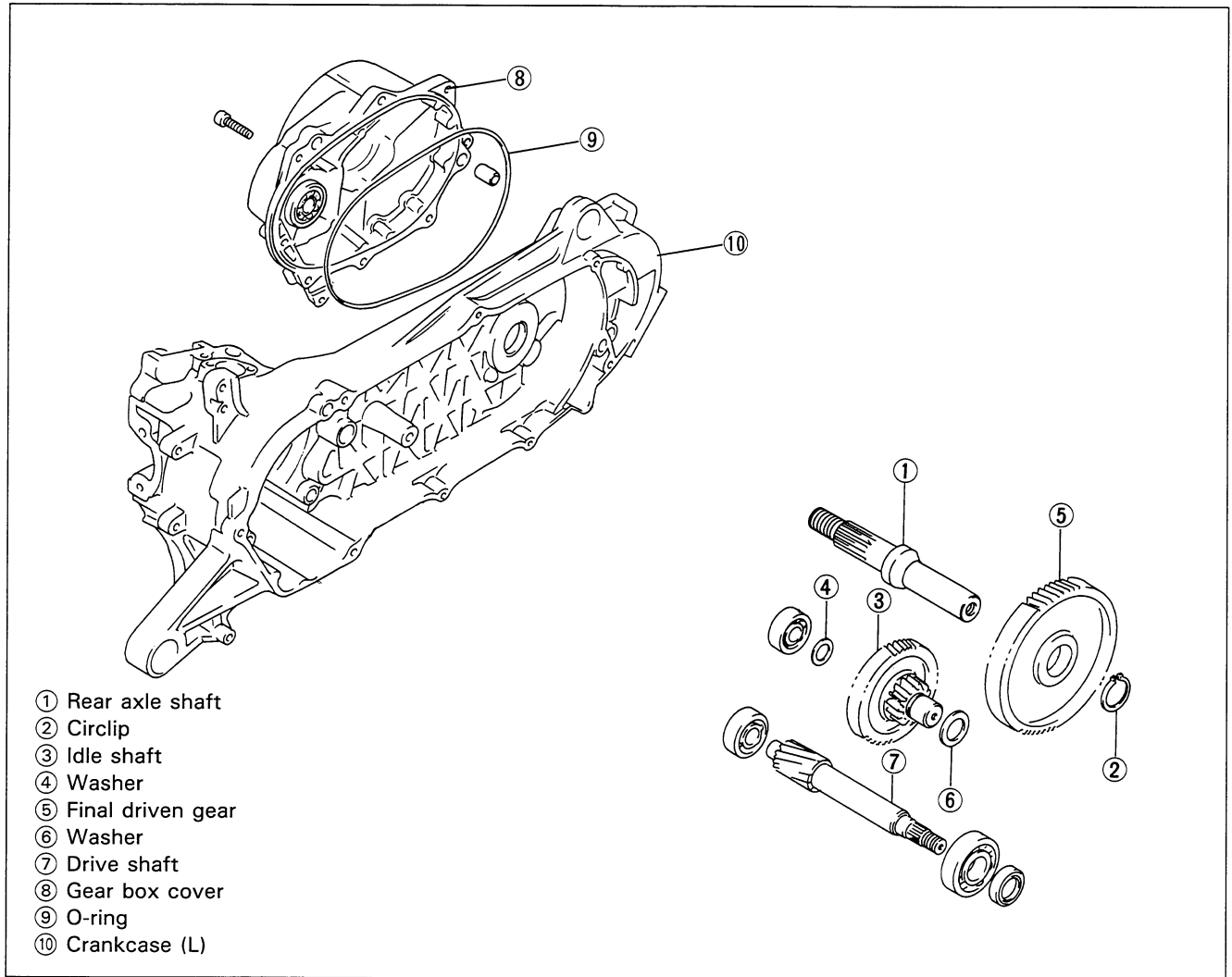

REMOVAL AND DISASSEMBLY

- Remove the air cleaner and muffler.
 - Remove the rear brake cable.
 - Remove the clutch cover.
 - Remove the clutch shoe assembly and movable driven assembly.
 - Remove the rear wheel.
-
- Remove the rear brake shoes.

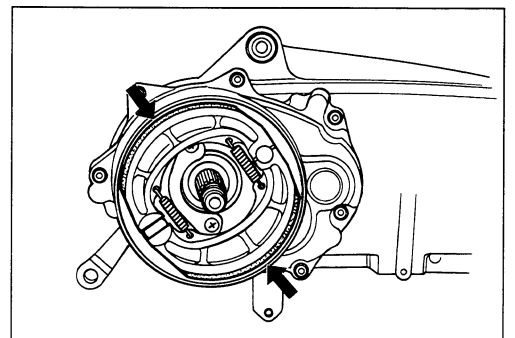
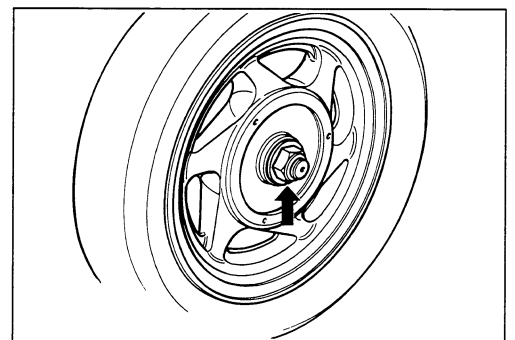

9-9 AP50V ('97-MODEL)

- Drain gear oil by removing the drain bolt.

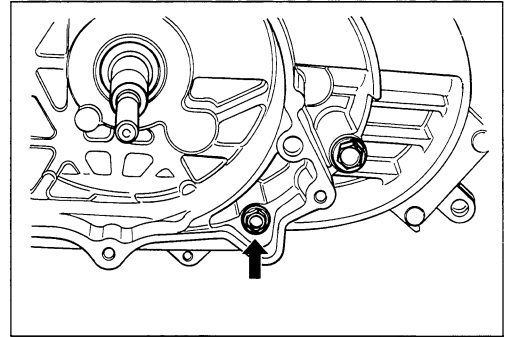

- Remove the gear box cover.

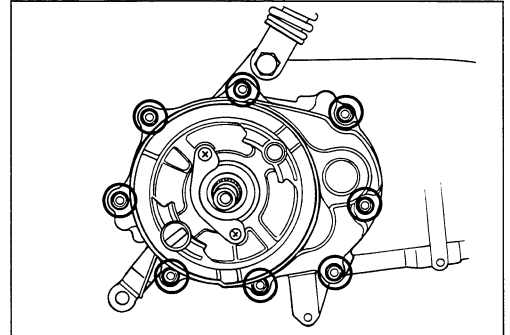

- Remove the final driven gear with rear axle shaft ①.
- Remove the washer ② and idle shaft ③.

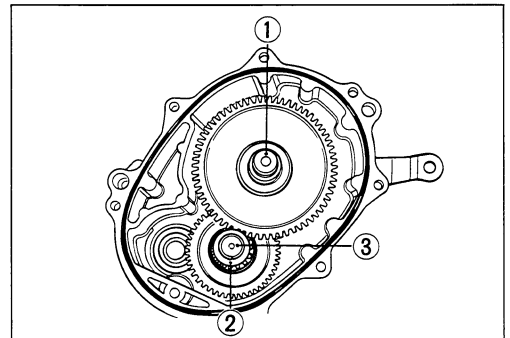

- Remove the rear brake cam lever ④, indicator plate ⑤ and brake camshaft ⑥.

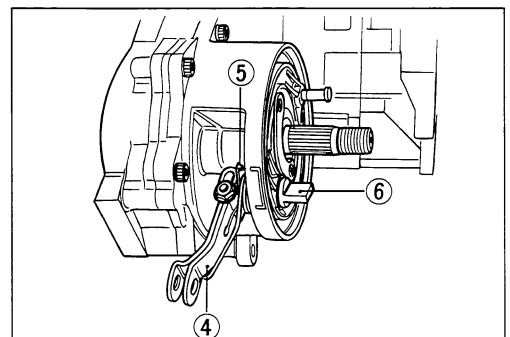

- Remove the driveshaft ⑦.

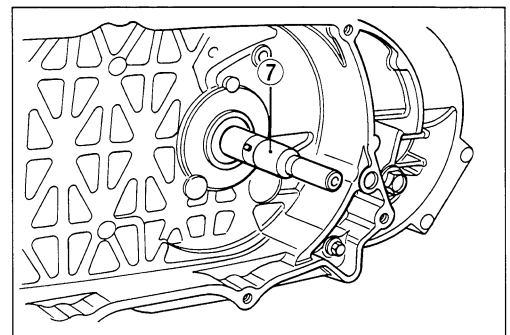

REASSEMBLY

Reassemble the transmission and gear box cover in the reverse order of removal and disassembly.

- Install the final driven gear with rear axle shaft ① to the gear box cover.
- Install the idle shaft ② and washer ③.
- Install the new O-ring ④.

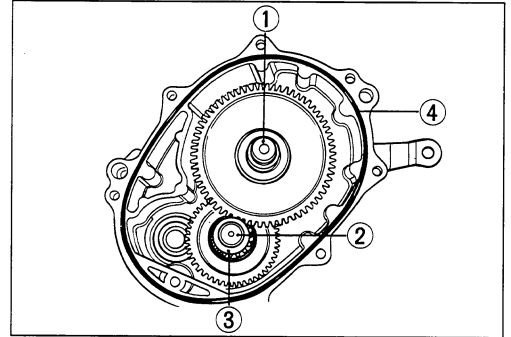

- Install the driveshaft ⑤ to the crankcase.

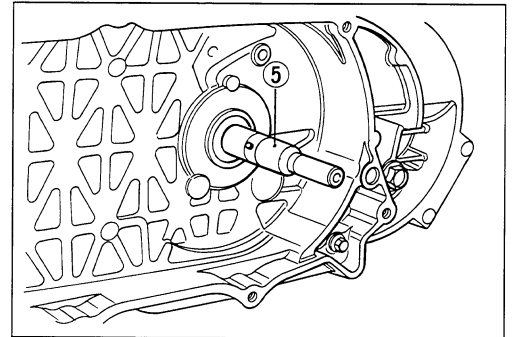

- Install the two dowel pins ⑥.
- Install the transmission with gear box cover.
- Tighten the bolts in a diagonal manner.

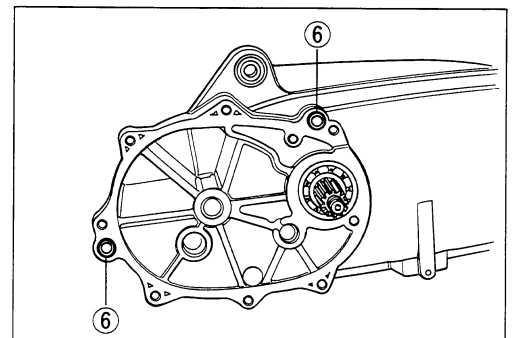

- Tighten the oil drain bolt ⑦.

 Oil drain bolt: 6 N·m (0.6 kg-m, 4.5 lb-ft)

- Fill the final gear box with final gear oil up to the oil level hole.

Oil capacity: 130 ml (4.4/4.6 US/Imp oz)

- Tighten the oil level bolt.

 Oil level bolt: 12 N·m (1.2 kg-m, 8.5 lb-ft)

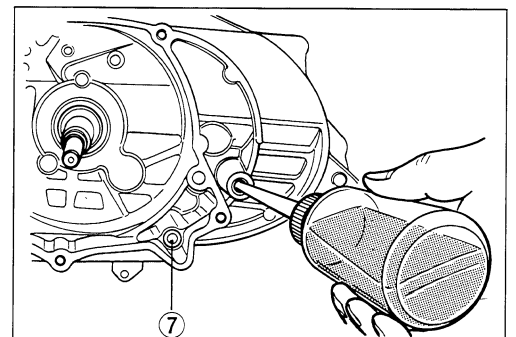

WIRING DIAGRAM

For P-02

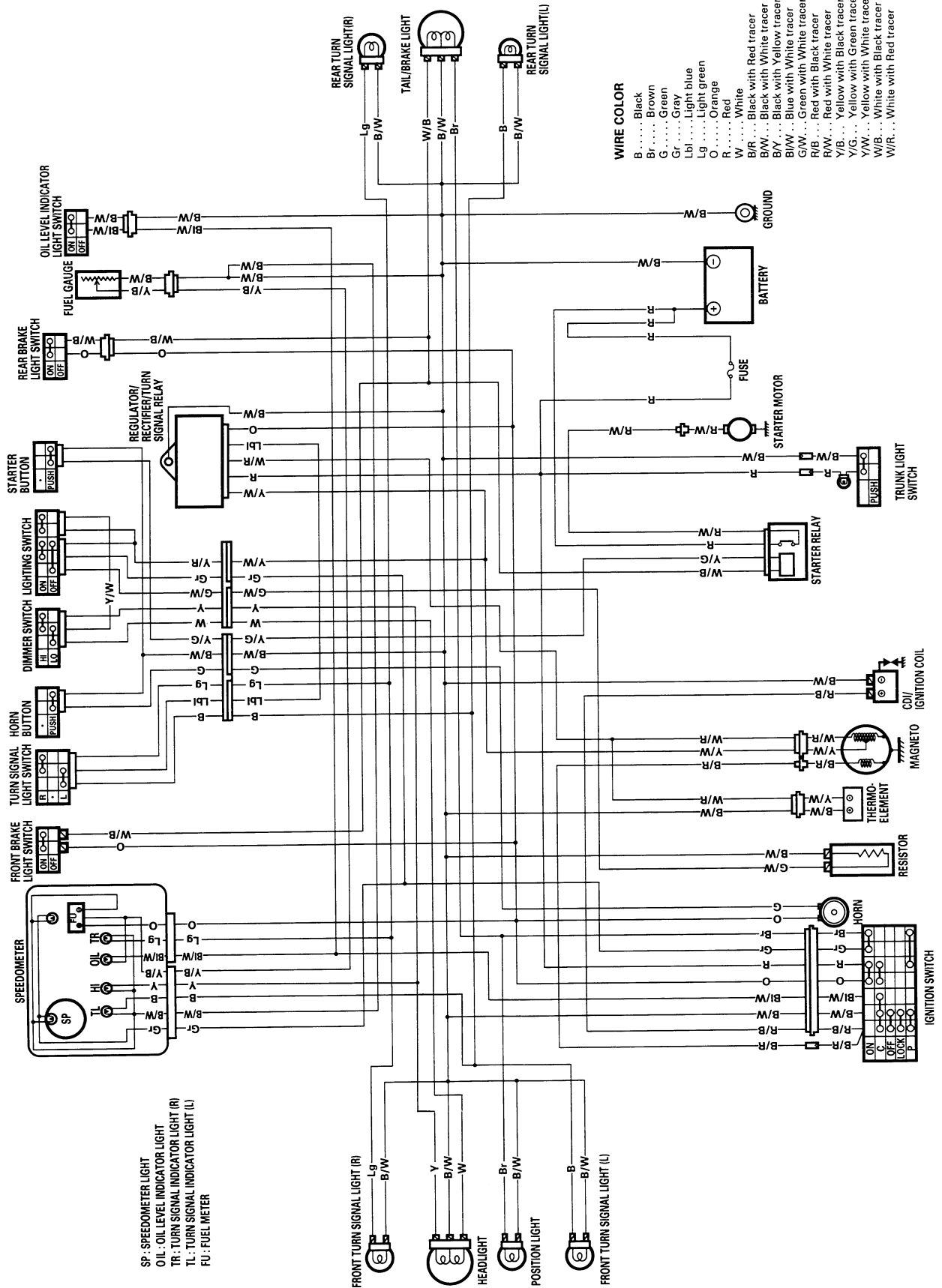

For P-37

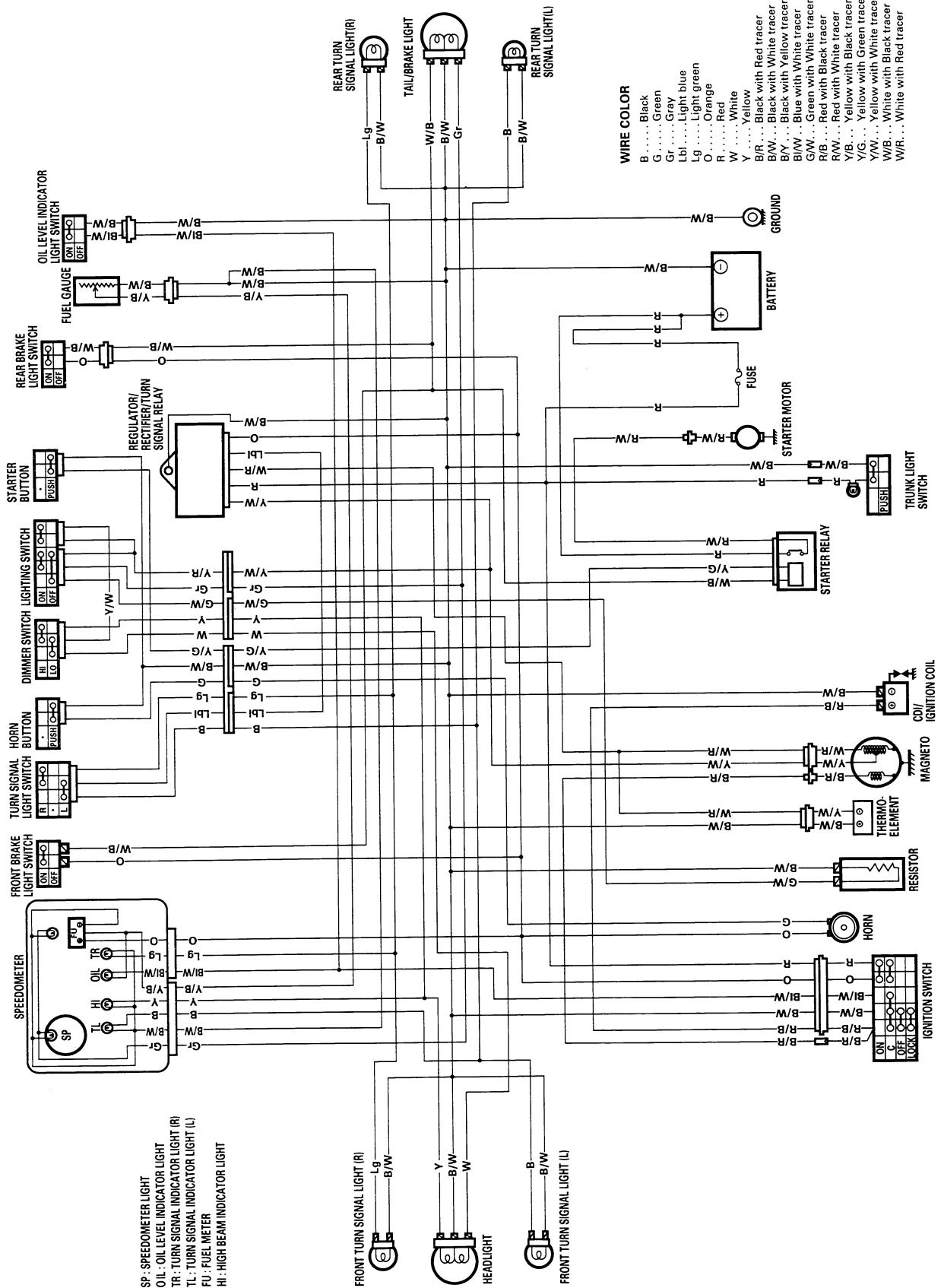

For P-04,22,26,34,53

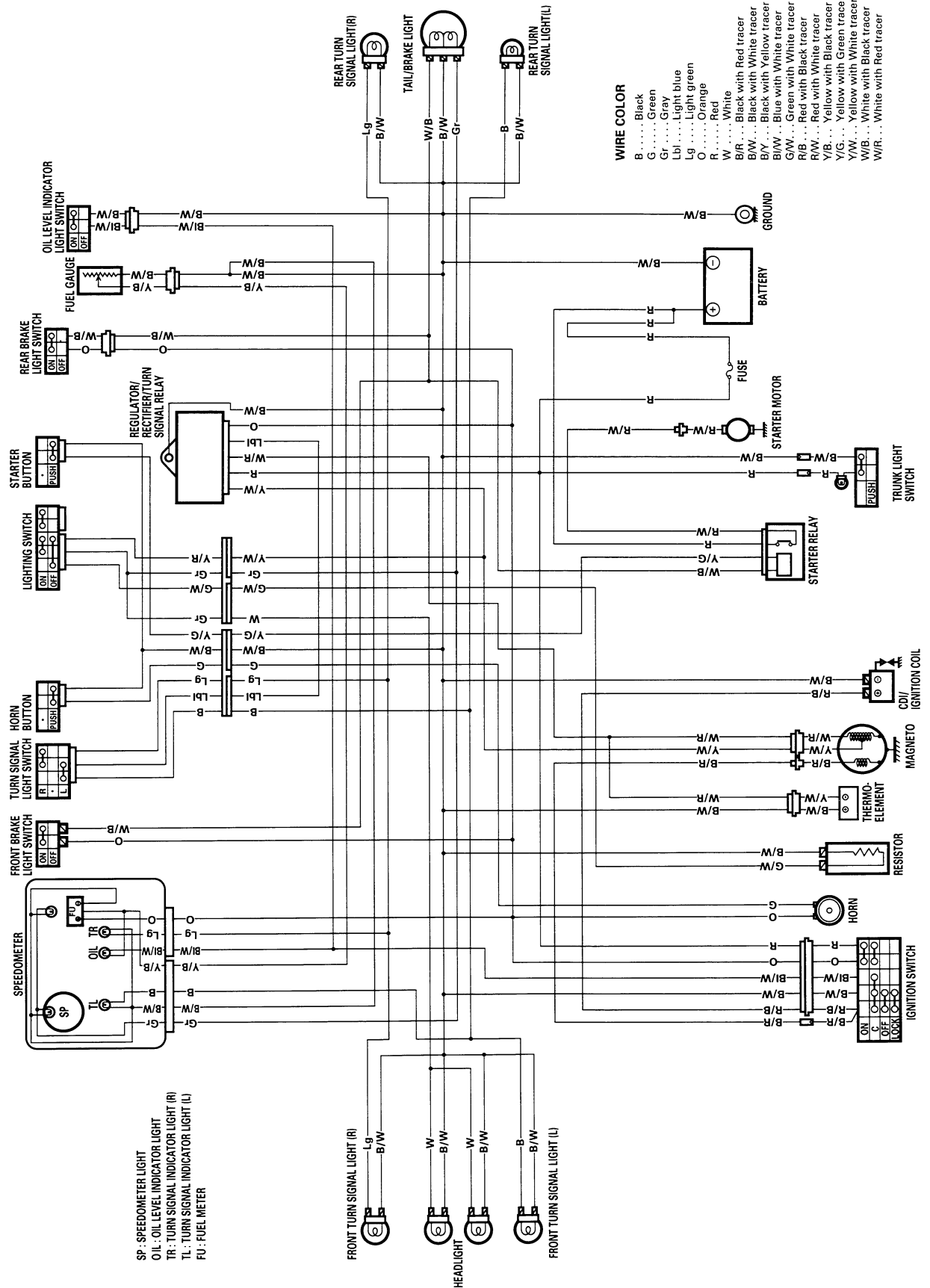

CARBURETOR OVERFLOW HOSE ROUTING

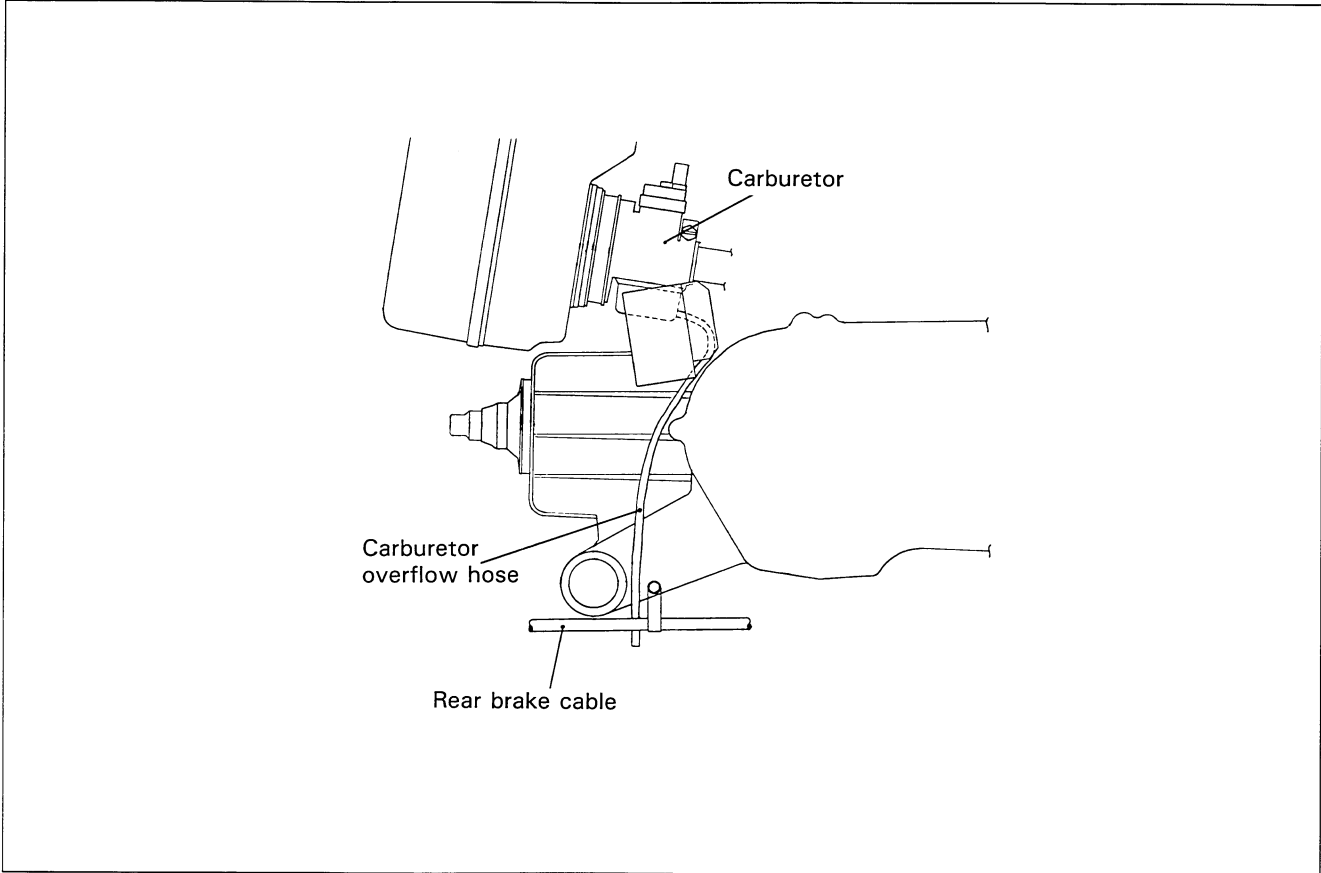

AP50W ('98-MODEL)

CONTENTS

SPECIFICATIONS	10- 1
SERVICE DATA	10- 2

NOTE:

Asterisk mark () indicates the New W-model specifications.*

SPECIFICATIONS

DIMENSIONS AND DRY MASS

Overall length	1 820 mm (71.7 in)
Overall width	660 mm (26.0 in)
Overall height	1 105 mm (43.5 in)
Wheelbase	1 255 mm (49.4 in)
Ground clearance	180 mm (7.1 in)
Dry mass	78 kg (172 lbs)

ENGINE

Type	Two-stroke, forced air-cooled
Intake system	Reed valve
Number of cylinder	1
Bore	41.0 mm (1.614 in)
Stroke	37.4 mm (1.472 in)
Piston displacement	49 cm ³ (3.0 cu. in)
Corrected compression ratio	6.7 : 1 ... P-22 7.4 : 1 ... The others
Carburetor	MIKUNI VM12SH, single ... P-34 MIKUNI VM14SH, single ... The others
Air cleaner	Polyurethane foam element
Starter system	Electric and kick
Lubrication system	SUZUKI "CCI"

TRANSMISSION

Clutch	Dry shoe, automatic, centrifugal type
Gearshifting	Automatic, variable ratio
Gear ratios, variable	Variable reduction ratio (2.768—0.871)
Final reduction ratio ...	14.960 (51/15 × 66/15) ... P-02,04,22 12.800 (51/15 × 64/17) ... P-26,34,53
Drive system	V-belt drive

CHASSIS

Front suspension	Telescopic, coil spring, oil damped
Rear suspension	Swingarm type, coil spring, oil damped
Steering angle	45° (right & left)
Caster	25°
Trail	68 mm (2.7 in)
Turning radius	1.8 m (5.9 ft)
Front brake	Disc brake
Rear brake	Internal expanding
Front tire size	100/90-10
Rear tire size	120/90-10

ELECTRICAL

Ignition type	Electronic ignition (CDI)
Ignition timing	18° B.T.D.C. at 4 000 r/min
Spark plug	NGK BPR6HS, DENSO W20FPR-U or BOSCH WR7BC
Battery	12V 14.4 kC (4Ah)/10HR ... P-53 12V 10.8 kC (3Ah)/10HR ... The others
Generator	Magneto
Fuse	10A
Headlight	12V 25/25W ... P-02 12V 15W × 2 ... The others
Brake light/Taillight ...	12V 21/5W
Turn signal light	12V 10W

CAPACITIES

Fuel tank	5.0 L (1.1 Imp gal)
Engine oil tank	0.8 L (0.7 Imp qt)
Final gear oil	130 ml (4.6 Imp oz)
Front fork oil	96 ml (3.4 Imp oz)

* These specifications are subject to change without notice.

SERVICE DATA

CYLINDER + PISTON + PISTON RING

Unit: mm (in)

ITEM	STANDARD		LIMIT	
Piston to cylinder clearance	0.06–0.07 (0.0024–0.0028)		0.120 (0.0047)	
Cylinder bore	41.005–41.020 (1.6144–1.6150) Measure at 20 (0.8) from the top surface		41.075 (1.6171)	
Piston diam.	40.940–40.955 (1.6118–1.6124) Measure at 15 (0.6) from the skirt end		40.885 (1.6096)	
Cylinder distortion	—		0.05 (0.002)	
Cylinder head distortion	—		0.05 (0.002)	
Piston ring free end gap	1st	R	Approx. 4.0 (0.16)	3.2 (0.126)
	2nd	R	Approx. 4.3 (0.17)	3.4 (0.134)
Piston ring end gap	1st & 2nd	R	0.10–0.25 (0.004–0.010)	0.80 (0.031)
Piston ring to groove clearance	1st		0.020–0.060 (0.0008–0.0024)	—
	2nd		0.020–0.060 (0.0008–0.0024)	—
Piston pin bore	10.002–10.010 (0.3938–0.3941)		10.030 (0.3949)	
Piston pin O.D.	9.995–10.000 (0.3935–0.3937)		9.980 (0.3929)	

CONROD + CRANKSHAFT

Unit: mm (in)

ITEM	STANDARD	LIMIT
Conrod small end I.D.	14.003–14.011 (0.5513–0.5516)	14.040 (0.5528)
Conrod deflection	—	3.0 (0.12)
Crank web to web width	35.0±0.1 (1.378±0.004)	—
Crankshaft runout	—	0.05 (0.002)

OIL PUMP

ITEM	SPECIFICATION
Oil pump reduction ratio	30.000 (30/1)
Oil pump discharge rate	0.9–1.1 ml (0.03–0.04 Imp oz) for 5 minutes at 3 000 r/min.

CLUTCH

Unit: mm (in)

ITEM	STANDARD	LIMIT
Clutch wheel I.D.	110.00–110.15 (4.331–4.337)	110.50 (4.350)
Clutch shoe thickness	3.0 (0.12)	2.0 (0.08)
Clutch engagement	3 300 ± 200 r/min.	—
Clutch lock-up	4 500 ± 300 r/min.	—

TRANSMISSION

Unit: mm (in) Except ratio

ITEM	STANDARD	LIMIT	
Reduction ratio	Variable 2.768–0.871	—	
Final reduction ratio	P-02,04,22	14.960 (51/15 × 66/15)	—
	The others	12.800 (51/15 × 64/17)	—
Drive belt width	16.9 (0.67)	16.0 (0.63)	
Driven face spring free length	69.8 (2.75)	66.3 (2.61)	

CARBURETOR

ITEM	SPECIFICATION		
	P-02	P-04	P-22
Carburetor type	MIKUNI VM14SH	←	←
Bore size	14 mm	←	←
I.D. No.	*09EM	*09ER	*09EN
Idle r/min.	1 700 ± 200 r/min.	1 800 ± 200 r/min.	1 700 ± 200 r/min
Float height	17.2 ± 1.0 mm (0.68 ± 0.04 in)	←	←
Main jet (M.J.)	# 57.5	# 55	# 60
Jet needle (J.N.)	3L30-2nd	3L30-4th	3L36-2nd
Needle jet (N.J.)	E-3	E-0	←
Pilot jet (P.J.)	# 20	# 17.5	←
Starter jet (G.S.)	# 25	←	←
Throttle cable play	3–6 mm (0.1–0.2 in)	←	←

CARBURETOR

ITEM	SPECIFICATION		
	P-26	P-53	P-34
Carburetor type	MIKUNI VM14SH	←	MIKUNI VM12SH
Bore size	14 mm	←	12 mm
I.D. No.	*09EP	*09EU	*09ES
Idle r/min.	1 700 ± 200 r/min.	←	←
Float height	17.2 ± 1.0 mm (0.68 ± 0.04 in)	←	←
Main jet (M.J.)	# 57.5	←	# 55
Jet needle (J.N.)	3L30-2nd	←	3L38-3rd
Needle jet (N.J.)	E-3	←	←
Pilot jet (P.J.)	# 20	←	←
Starter jet (G.S.)	# 25	←	←
Throttle cable play	3–6 mm (0.1–0.2 in)	←	←

ELECTRICAL

Unit: mm (in)

ITEM		SPECIFICATION		NOTE
Ignition timing		18° B.T.D.C. at 4 000 r/min.		
Spark plug		Type	NGK: BPR6HS DENSO: W20FPR-U BOSCH: WR7BC	
		Gap	0.7–0.8 (0.028–0.031)	
Spark performance		Over 8 (0.3) at 1 atm.		
Ignition coil resistance		Secondary	*8–15 kΩ	Plug cap— Ground
Magneto coil resistance		Lighting	*0.5–2.5 Ω (Y/W—Ground)	
		Charging	*1.0–3.0 Ω (W/R—Ground)	
		Exciting	*200–400 Ω (B/R—Ground)	
Generator no-load voltage		More than 25V (AC) at 5 000 r/min.		W/R—Ground
Regulated voltage		13.0–15.0 V at 5 000 r/min.		
Magneto Max. output		90 W at 5 000 r/min.		
Starter relay resistance		50–90 Ω		
Battery	Type designation	FB4L-B		P-53
		YT4L-BS		The others
	Capacity	12 V 14.4 kC (4 Ah)/10 HR		P-53
		12 V 10.8 kC (3 Ah)/10 HR		The others
	Standard electrolyte S.G.	1.280 at 20°C (68°F)		P-53
1.320 at 20°C (68°F)		The others		
Fuse size		10 A		

WATTAGE

Unit: W

ITEM		SPECIFICATION	
		P-04,22,26,34,53	P-02
Headlight	HI	15 × 2	25
	LO		25
Position light			5
Brake light/Taillight		21/5	←
Turn signal light		10	←
Speedometer light		1.2 × 2	←
Turn signal indicator light		2	←
Oil level indicator light		2	←
High beam indicator light			2
Trunk light		2	←

BRAKE + WHEEL

Unit: mm (in)

ITEM		STANDARD	LIMIT
Brake lever play	Rear	15–25 (0.6–1.0)	—
Brake drum I.D.	Rear	—	120.7 (4.75)
Brake lining thickness	Rear	—	1.5 (0.06)
Brake disc thickness	Front	4.0±0.2 (0.157±0.008)	3.5 (0.14)
Brake disc runout	Front	—	0.30 (0.012)
Master cylinder bore	Front	11.000–11.043 (0.4331–0.4348)	—
Master cylinder piston diam.	Front	10.957–10.984 (0.4314–0.4324)	—
Brake caliper cylinder bore	Front	30.230–30.306 (1.1902–1.1931)	—
Brake caliper piston diam.	Front	30.150–30.200 (1.1870–1.1890)	—
Wheel rim runout	Axial	—	2.0 (0.08)
	Radial	—	2.0 (0.08)
Wheel axle runout	Front	—	0.25 (0.010)
Wheel rim size	Front	J10×MT2.50	—
	Rear	J10×MT2.50	—
Tire size	Front	100/90-10	
	Rear	120/90-10	
Tire tread depth	Front	—	1.6 (0.06)
	Rear	—	1.6 (0.06)

SUSPENSION

Unit: mm (in)

ITEM	STANDARD	LIMIT	NOTE
Front fork stroke	72 (2.8)	—	
Front fork spring free length	—	265 (10.4)	
Front fork oil level	91 (3.6)	—	
Rear wheel travel	63 (2.5)	—	

TIRE PRESSURE

P-26, 34, 53

COLD INFLATION TIRE PRESSURE	SOLO RIDING		
	kPa	kg/cm ²	psi
FRONT	125	1.25	18
REAR	175	1.75	25

P-02, 04, 22

COLD INFLATION TIRE PRESSURE	SOLO RIDING			DUAL RIDING		
	kPa	kg/cm ²	psi	kPa	kg/cm ²	psi
FRONT	125	1.25	18	125	1.25	18
REAR	175	1.75	25	250	2.50	36

FUEL + OIL

ITEM	SPECIFICATION	NOTE
Fuel type	Gasoline used should be graded 85-95 octane or higher. An unleaded gasoline is recommended.	
Fuel tank capacity	5.0 L (1.1 Imp gal)	
Engine oil type	Use SUZUKI CCI SUPER OIL. If they are not available, use a good quality 2-stroke oil rated FC under JASO classification.	
Engine oil tank capacity	0.8 L (0.7 Imp qt)	
Final gear oil type	SAE 10W/40	
Final gear oil capacity	130 ml (4.6 Imp oz)	
Front fork oil type	Fork oil #10	
Front fork oil capacity (each leg)	96 ml (3.4 Imp oz)	
Brake fluid type	DOT 4	

Prepared by
SUZUKI MOTOR ESPAÑA, S. A.

3rd Ed. June, 1998

1st Ed. March, 1995

Part No. 99500-10432-01E

Printed in Japan

SUZUKI MOTOR ESPAÑA, S. A.