

PUCH PUCH PUCH IMPORTANT NOTICE PUCH PUCH PUCH

PUCH PUCH PUCH PUCH PUCH PUCH PUCH PUCH PUCH PUCH PUCH PUCH PUCH PUCH PUCH PUCH

PUCH PUCH PUCH PUCH PUCH PUCH PUCH PUCH PUCH PUCH PUCH PUCH PUCH PUCH PUCH PUCH

Read this owner's manual carefully

The Magnum X is designed for use only as follows:

- Off-road use only — not for use on public roads.
- Single rider only — weight limit 98 pounds.
- Parent supervision required during operation.
- Riders should always wear a helmet and protective clothing.
- Riders should always ride safely.
- Riders should be warned not to touch any moving parts or heated areas of the machine.
- Observe maintenance requirements before riding — refer to applicable sections of this owner's manual.

The Magnum X is designed and manufactured for use only off of public roads. It is not subject to Federal Motor Vehicle Safety Standards as it is not equipped or approved for operation on public streets, roads, or highways at any time.

PUCH PUCH PUCH PUCH PUCH PUCH PUCH PUCH PUCH PUCH

Throughout this manual, WARNING, CAUTION and NOTE carry different degrees of meaning:

WARNING

means that there is the possibility of personal injury to yourself and others.

CAUTION

means that there is the possibility of damage to the vehicle.

NOTE

indicates points of particular interest for more efficient and convenient operation. We recommend that you take particular notice of these items when reading this manual.

All information, illustrations, photographs and specifications contained in this manual are based on the latest product information available at the time of publication. The right is reserved to make changes at any time without notice.

Dear Puch Parent,

Thank you very much for choosing the Puch Magnum X.

The Puch Magnum X is ready for your children to learn the fun of off-road riding. It is a machine built with the best of what Puch has gained throughout nearly a century of experience in the manufacture of motorcycles, and is specifically meant for use by children.

The Magnum X is designed with features taking into consideration of children's physical and mental capabilities. We on the part of Puch have to count heavily on their parents for ensuring maximized safety. In this sense, this owner's manual is intended for the parents, with a strong hope that it will also be read by the young riders themselves.

A machine needs care. We hope you will avail yourself of the skill and facility of your Puch dealer. If you are experienced in do-it-yourself mechanical work, please consult the technical parts of this manual, or the Magnum X repair and parts manual, before you do it yourself. Remember, safety comes first, this manual has been written with this thought as its governing principle.

Steyr Daimler Puch of America Corporation

Box 7777

Greenwich, Ct. 06830

MESSAGE TO THE PARENTS

Children can be impatient; the sight of a new motorcycle often excites their imagination; and the expectation often overrides the importance of safety precautions. This is your responsibility.

Please, go through this manual with the young rider, and have him or her understand not only the mechanism but also the rules of courtesy and safety precaution.

Specific additional safety items to be considered include:

- Supervise operation of this Magnum X AT ALL TIMES.
- Do not allow the rider to operate the Magnum X beyond his riding ability.
- Use of the Magnum X should be controlled by the parents in relation to the rider's age.
- Beware of hazardous situations and instruct the rider to beware of hazardous situations.
- Before first use of the Magnum X, read the Owner's Manual carefully to become familiar with the features, and safety and maintenance requirements of the motorcycle, instruct and review these items with rider.
- Before rider's first use of the Magnum X, be sure that the rider is familiar with the control and operation of the Magnum X.

PUCH recommends first use of the Magnum X in a safe, open area for the rider to become familiar with the controls, operation, and handling characteristics of the Magnum X.

- Before each use, perform daily inspections with the rider to ensure safe riding. Check specifically:

Brakes

Throttle operation (Smooth opening and smooth automatic return)

Control operation

Fuel line connections

Tire pressure

Oil and fuel level

Chain tension

General condition

- Be sure that the rider wears a helmet and protective clothing (gloves, leather or heavy cloth pants, shirt or jacket, goggles).
- The Magnum X is not to be used on public roads AT ANY TIME.
- For single rider only.
- Drain the fuel tank and carburetor of fuel prior to transporting the motorcycle.
- Caution the rider and others near the Magnum X not to be close or to touch any moving parts or any heated areas such as the engine and exhaust system.
- Do not modify the exhaust system. The excess noise antagonizes everyone and creates a bad image for motorcycles.

INDEX

1	Tips for riding	6
2	Vehicle identification numbers	13
3	Technical data	14
4	Controls	16
5	Power/speed restrictor removal	17
6	Inspection and Maintenance	19
7	Lubricating and maintenance chart	33
8	Wiring diagram	34

1 TIPS FOR RIDING

You must learn driving techniques yourself. You may get some ideas from watching experts and professionals, and then try them yourself. There is no such thing as a textbook which you need only read through in order to learn dirt riding. The following tips are merely recommendations that may be helpful.

WARNING

Always wear your helmet and protective clothing when you ride your new bike. Your machine should only be ridden on private ground and only under the supervision of an adult.

Dirt riding is lots of fun but differs significantly from riding on normal roads. Dirt riding requi-

res a technique of its own, as well as excellent physical condition. If you are as yet unexperienced in dirt riding, you would be well advised to follow the advice below.

Before beginning a ride:

Don't forget that for dirt riding you need not only the right kind of bike, but also appropriate clothing. Any dealer will be glad to advise you regarding equipment:

leathers, boots, goggles, crash helmet and gloves, etc. protect you from stones, tree roots and so on.

Ride only on approved trails. Permission should be obtained in advance from property owners to ride on their land.

You should avoid going on long rides alone. Be sure to take the weather into consideration.

Trails that present no problems in dry weather may be impassable when it rains.

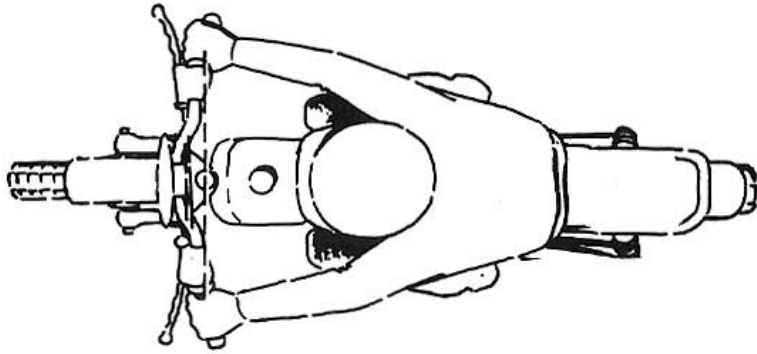

Fig. a

Riding tips:

Adjust the position of the handlebars, controls and brake levers and the foot pegs so that they correspond to your physical build. Remember, though, that you will sometimes have to ride standing up on the foot pegs. Your arms will be subjected to the least stress when the handlebars are adjusted as shown in fig. a. The foot pegs and pedals should be so adjusted that the foot remains horizontal (see fig. b).

WARNING

Pointing the toes downward should be avoided at all costs as when the foot is in this position, stones or roots may force it under the peg, leading to injury.

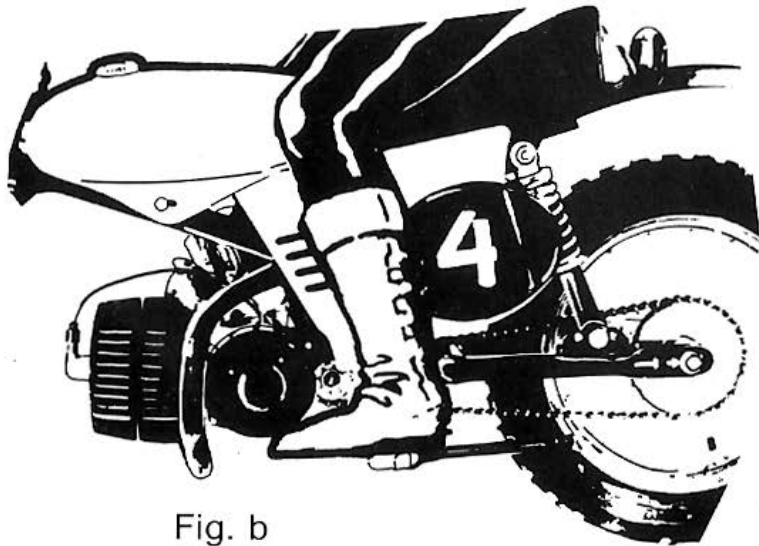

Fig. b

Don't begin with long rides but rather seek out particular types of terrain to master, e.g. a hill, a muddy stretch, etc. Practice, for example, driving uphill until you can manage it with no trouble and feel sure of yourself. Then practice other types of terrain in the same manner. Only when you have thus become familiar with the most common types of terrain and have learned the necessary riding techniques you should undertake longer trips.

Driving uphill

Begin with mild inclines. Don't start from a dead stop at the bottom; gather momentum on the flat. Try to put weight on the front and rear wheels by sitting back and leaning forward with the upper body. Incorrect weight distribution can cause the following: if you sit too far back the front part of the machine will come off the ground, while if the weight is too far forward, the back wheel will hold poorly and spin. In both cases there is considerable danger of a spill. The proper position is shown in fig. c. The front wheel may lift slightly—when you have more experience you will find that in dirt riding it is often necessary to ride without weight on the front wheel to compensate for unevenness in the terrain.

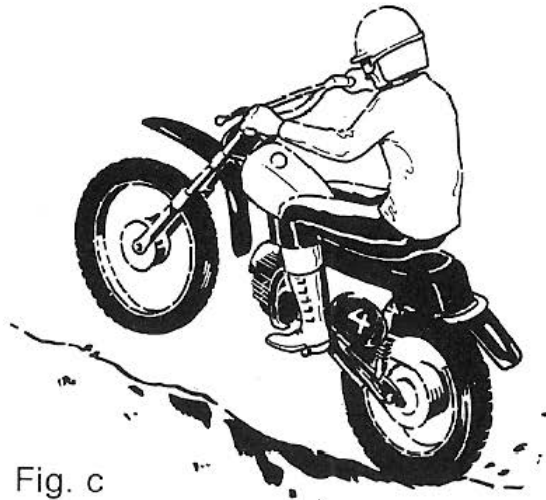

Fig. c

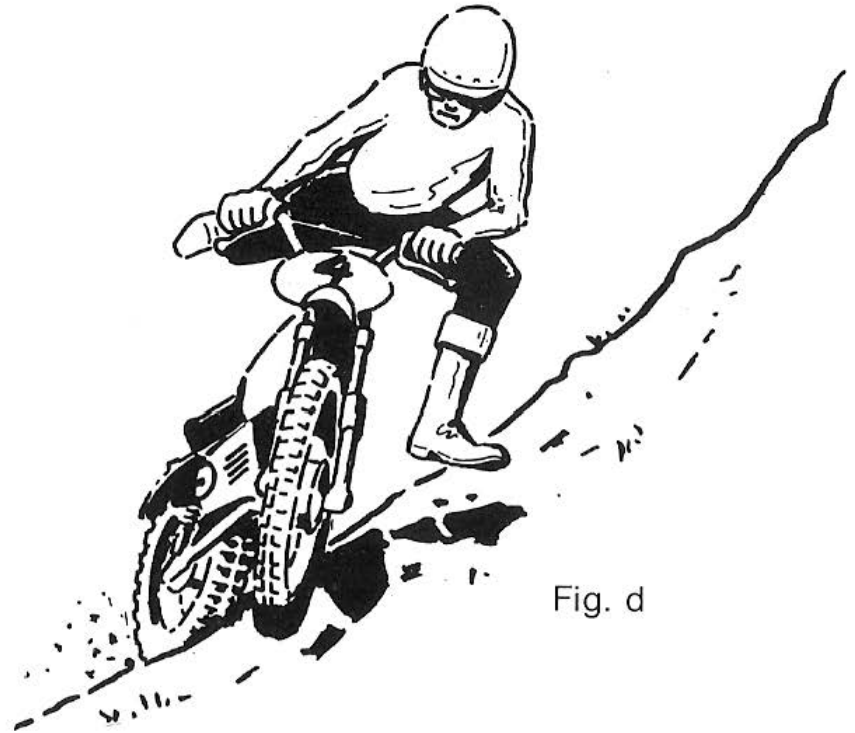

Fig. d

Keep the engine speed up.

If you see that you won't be able to make it up the grade, turn the machine to the slope and lay it uphill (fig. d). Try to use both brakes. If you can't stop the machine, get off (fig.d). This is safer than to try to stay on. If you're unfamiliar with the route, ride only with a speed that will allow you to stop at any time; you may otherwise be unpleasantly surprised by an obstacle.

Driving downhill

Riding downhill is the most difficult part of dirt riding. If the incline is slight, ride as if on a flat surface. On a steeper hill, don't accelerate and use the engine to brake. With a yet greater incline both brakes should also be applied, but the wheels must not lock.

WARNING

Most importantly—never try to stay with an out-of-control bike.

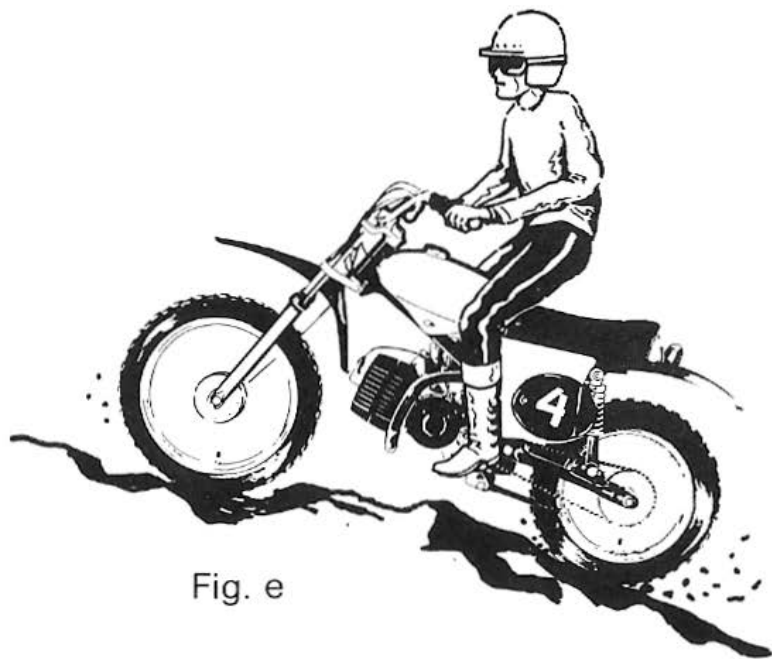

Fig. e



Fig. f

Ridges, stones, small unevennesses

In this situation, ride standing up on the footpegs so that your body doesn't have to absorb all the bumps (fig. e). If you drive such a stretch sitting you will quickly lose contact with the machine and will have to reduce your speed drastically, or crash.

Narrow curves

Fig. f. shows the correct position for rider and bike. The inside foot is used to push, but only when the bike slips. When this happens the bike may be supported with the foot to prevent a spill.



Fig. g

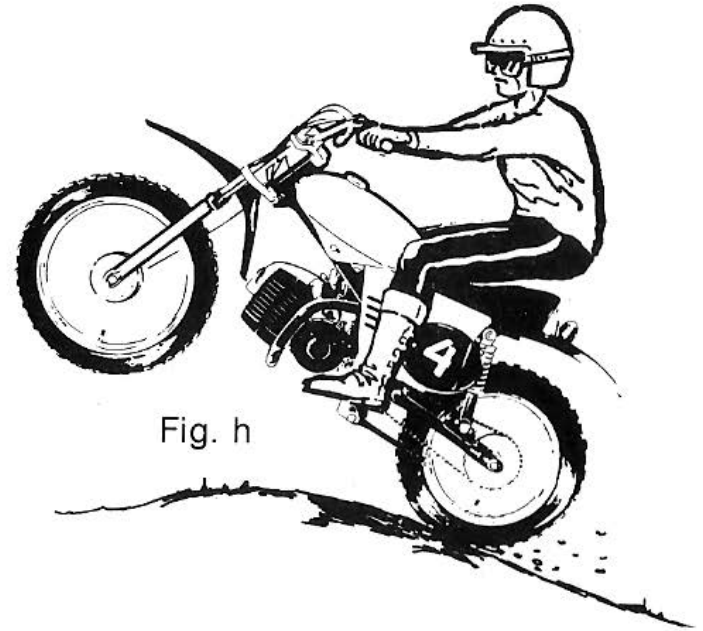

Fig. h

Riding in mud, sand, snow and ice

If you aren't familiar with the route it's better to ride slowly with feet off the foot pegs (fig. g). If you already know the way, then ride as fast as possible. In ice and snow, the more slippery it is the faster you should drive, as this increases the bike's stability. Brake only when absolutely necessary.

Start slowly and don't accelerate abruptly. On surfaces slippery with snow and ice tire pressure should be reduced to increase tire grip.

Bumps, ditches, large unevennesses

All of these obstacles should be jumped. For this, the front part of the bike should be lifted. This technique requires practice and experience. Before the jump open the throttle. When this is done correctly the front wheel comes up on its own with very little if any physical force. If the throttle is operated correctly, the amount of lift can be regulated.

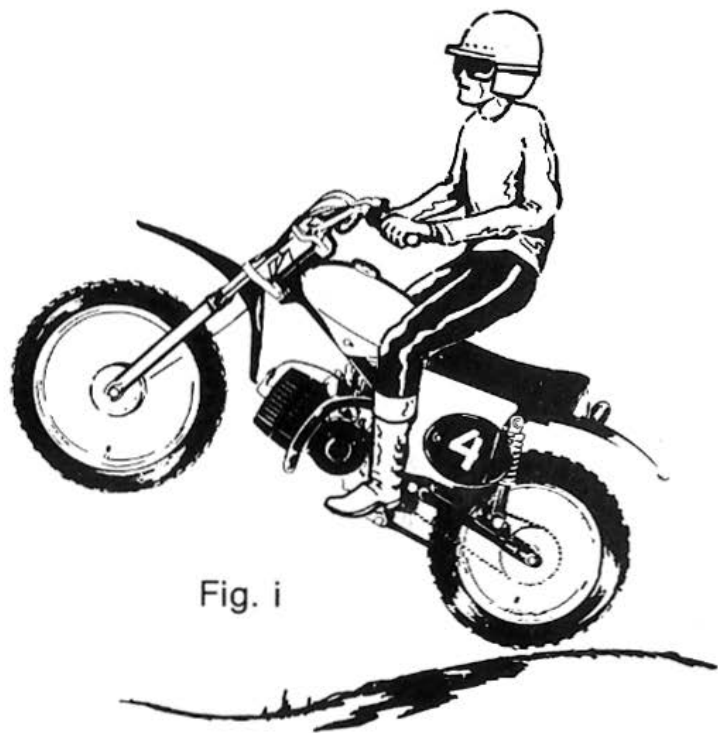

Fig. i



Fig. j

Fig. h shows the correct take-off and fig i the correct landing.

Fig. j shows what happens when the machine doesn't lift or lifts too little.

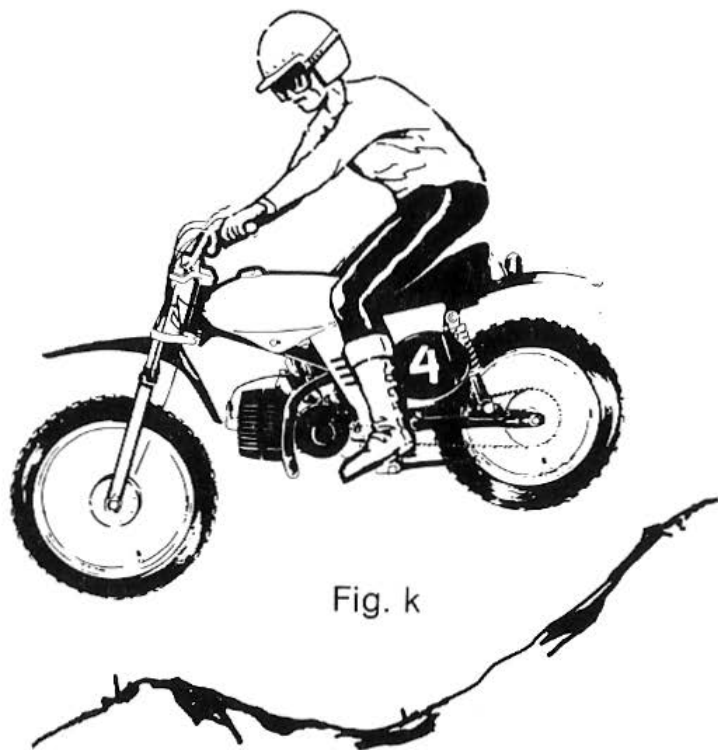

Fig. k

RIGHT

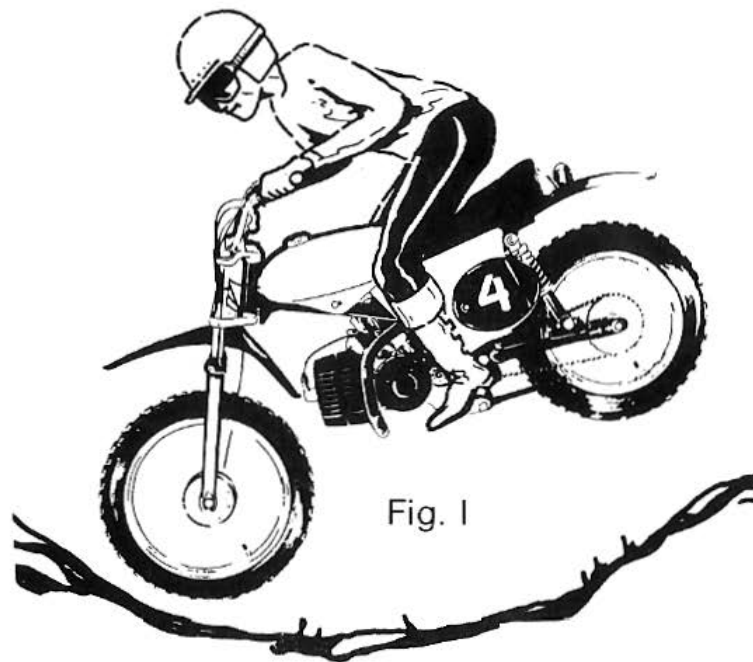

Fig. l

WRONG

A correct jump over a bump or ditch is shown in fig. k, while how a spill occurs at a too low speed or when the machine isn't lifted in time is shown in fig. l.

2 VEHICLE IDENTIFICATION NUMBERS

ENGINE NUMBER

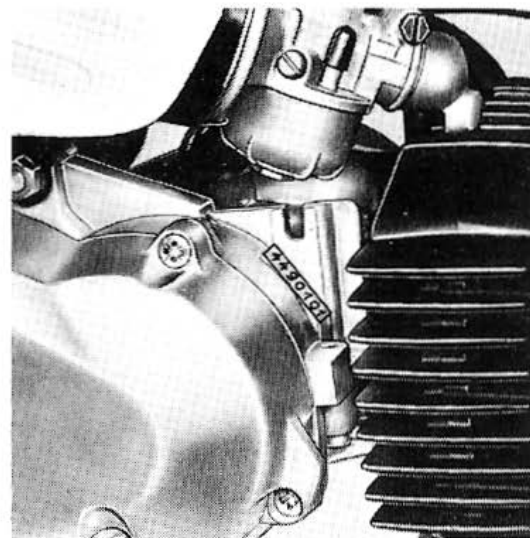

FRAME NUMBER



3 TECHNICAL DATA

Engine

Type	1-cylinder-2stroke engine, air-cooled
Maximum output	3.5 hp at 7000 rpm
Maximum torque	2.75 ft/lb at 5000 rpm (0.38 mkp)
Compression ratio	11:1
Bore	1.49 in. (38 mm)
Stroke	1.69 in. (43 mm)
Displacement	48.8 cc
Cylinder material	Alu-alloy with cast iron liner
Cylinder head	Alu-alloy
Crankshaft	Steel
Inlet and exhaust	Ports
Port control	Piston
Lubrication	Petroil lubrication 1:50
Top speed	20 m.p.h. (32 km/h); without restrictive devices 31 m.p.h. (50 km/h)

Carburetor

Type	Bing 1/17
Main jet	84
Needle jet	2,20
Needle	1
Needle position	3rd notch from top

Electrical equipment

Ignition	Magneto ignition, Bosch
Ignition timing	RCP1, 6V 26—5/10W .04—.05 in. (1,0-1,2 mm) in advance of TDC
Spark plug	Bosch W 5A/W225 T1
Spark gap	.016—.020 in. (0,4—0,5 mm)

Transmission

Gearbox	1-speed gearbox
Type of gearbox	1-speed automatic transmission
Clutch	Centrifugal running in oil
Primary transmission	Helical gears
Secondary transmission	Chain $1/2'' \times 3/16''$
Gear ratios	
Engine gear	106:21, $i = 5.05$
Gear rear wheel	34:13, $i = 2.61^*$
Frame	Tubular frame
Spring suspension front	Telescopic fork, 3.14 in (80 mm) spring travel
Suspension rear	Control arm with hydraulic suspension unit, 2.16 in (55 mm) spring travel
Brakes	Internal expanding shoe brakes
Dia. of brake drums	3.49 in (90 mm)
Tire equipment, front	2.50 x 14
Tire equipment, rear	2.75/3.00 x 12
Tire pressure, front/rear	11,4—18,5/14,2—21,3 psi (0,8—1,3/1,0—1,5 bar) depending on the type of terrain and the weight of the rider.
Fuel tank	0.93 US-gal; 3.5 litres

Dimensions

Wheelbase	39.3 in. (1000 mm)
Overall length	58.6 in. (1490)
Handlebar height	34.6 in. (880 mm)
Handlebar width	26 in. (680 mm)
Ground clearance	6.8 in. (175 mm)
Dry weight	83.7 lb. (38 kg)
Permissible load	98 lb.

CAPACITY AND QUALITY OF LUBRICANTS (see bypacked lubrication table)

ENGINE	Mixture of regular gasoline with Puch Maxi Mix 50:1. For further recommendations refer to page 22
GEARBOX	7,44 oz (220 cc) Automatic-Transmission-Fluid
CHASSIS PARTS	Summer and winter motor oil
WHEEL BEARING	Summer and winter Lithium base grease
CHAIN	Summer and winter SAE 90

*) 12-tooth-sprocket bypacked. It should only be used when riding on soft terrain. When riding on solid terrain the engine might be overrevved.

FRONT BRAKE LEVER

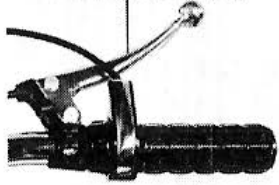

THROTTLE TWIST GRIP

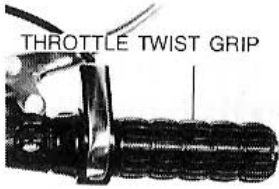

FUEL VALVE

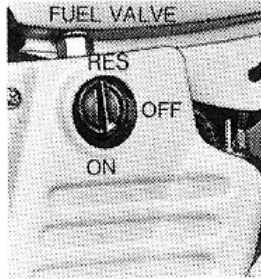

KICKSTARTER

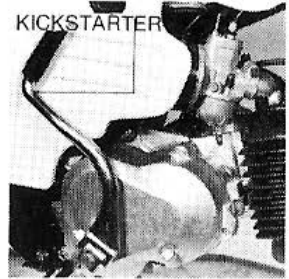

4 CONTROLS

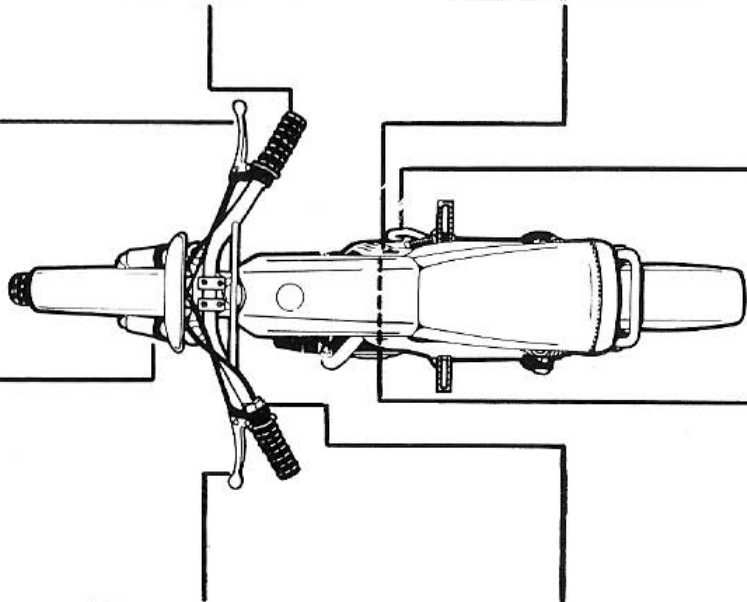

SPEEDOMETER

REAR BRAKE LEVER

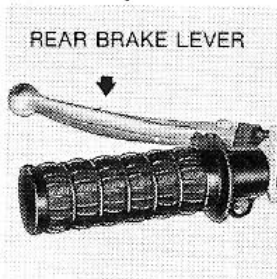

ENGINE KILL BUTTON

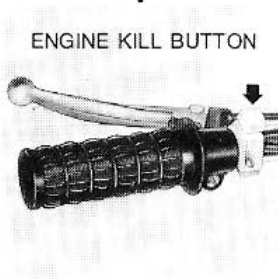

CARBURETOR

CHOKE

PRIMER

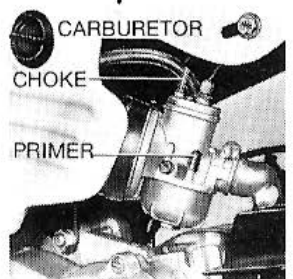

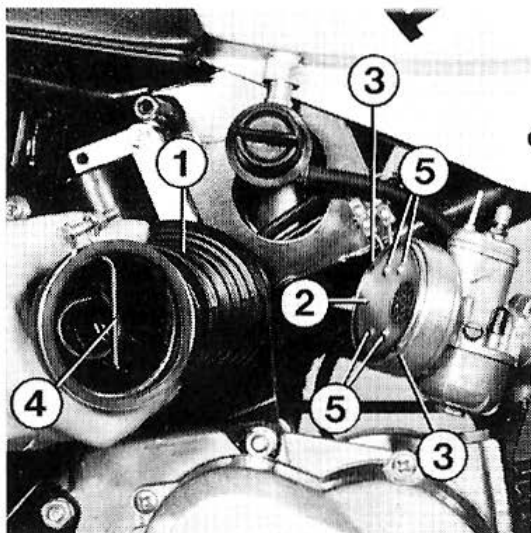
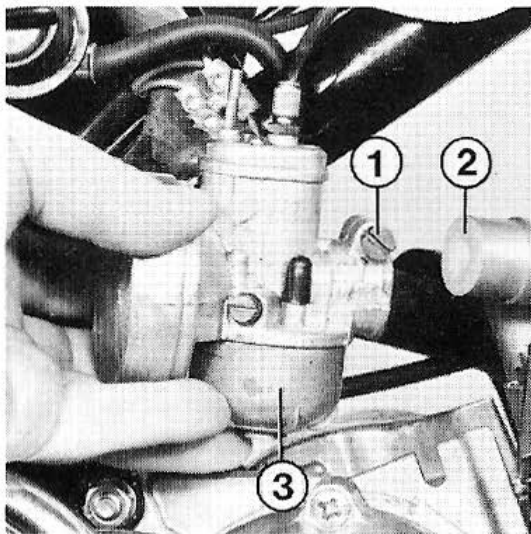

Fig. A

Fig. B



5 POWER/SPEED RESTRICTOR REMOVAL

NOTE

Two restrictive devices are installed in the intake system. The two restrictive devices, a metal plate on the front of the airfilter and a restrictive orifice between carburetor and intake manifold reduce the fuel-air mixture supply and the power output as well. This enables the young rider to develop his riding skills gradually with a reduced power output. By removing the restrictive devices the engine reaches its maximum output.

WARNING

The two restrictive devices should only be removed, when in the judgement of the parents, the rider has developed sufficient skills to be able to safely operate the machine with the two restrictive devices removed.

REMOVING BOTH RESTRICTIVE DEVICES

Remove fixing screws from the right side engine shroud. Loosen clamping bracket of rubber boot (fig. A/1) and remove rubber boot. Pull filter disc with metal plate (fig. A/2) out of carburetor. Loosen clamping screw of carburetor (fig. B/1)

and remove carburetor from intake manifold. Remove restrictive orifice (fig. B/2) from intake manifold. When mounting carburetor note that the float chamber (fig. B/3) is vertical. Thereafter, if you intend to throttle the MAGNUM X again, use a new filter part no. 362.1.15.040.2. If, however, you do not intend to throttle the machine again, remove the metal plate (fig. A/2) from the filter. The metal plate (fig. A/2) is welded on two points of the filter (fig. A/3). Remove one welding point with a file. Press metal plate out of filed point using a screwdriver and move metal plate by hand up and down until metal plate breaks out of filter. Fit filter so that welding points are outside. Fit rubber boot so that the spring (fig. A/4) presses the filter into the carburetor housing.

WARNING

On no account must only one restrictive device be removed. A metal plate once removed from the filter must not be refitted again. When mounting a filter with metal plate note that the open end of the spring (fig. A/4) is between the four elevations (fig. A/5) so that the bore of the metal plate remains free.

6 INSPECTION AND MAINTENANCE

FRONT BRAKE

WARNING

If an adjustment of the front brake is required, use the adjuster at the brake cover plate (fig. 1). Turning the adjuster to the left results in increase of the play, turning to the right decreases the amount of play. The correct travel measured at the end of the hand brake lever is $\frac{3}{4}$ ".

REAR BRAKE

WARNING

The play of the rear brake lever should be the same as the front brake lever or $\frac{3}{4}$ ". To adjust the play use the adjuster at the rear brake cover plate (fig. 2). Turning the adjuster to the left results in an increase of the play, turning the adjuster to the right will decrease the amount of play.

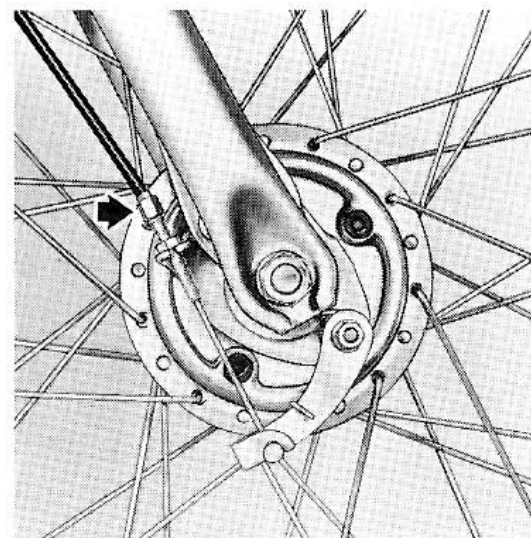
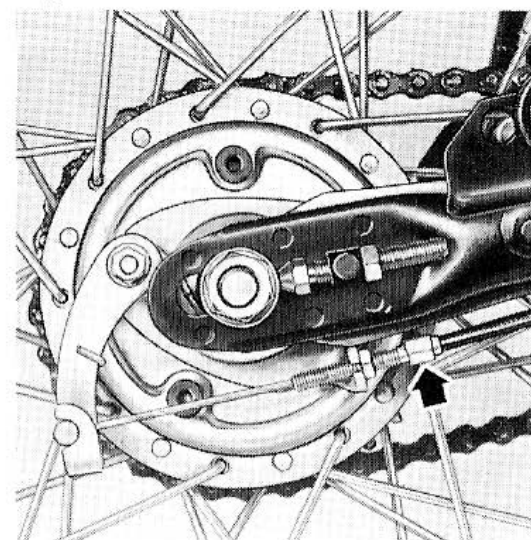

Fig. 1

Fig. 2



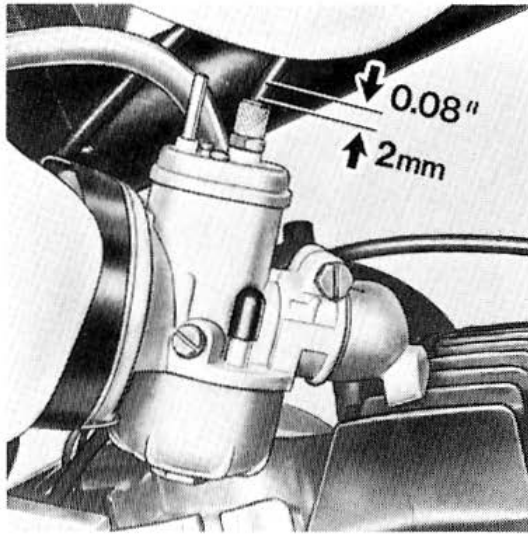
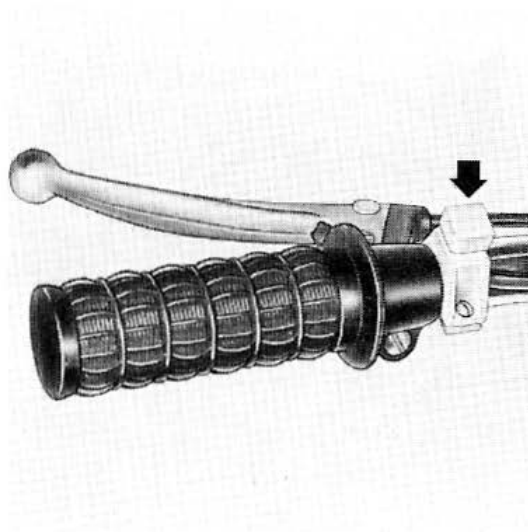

Fig. 3

Fig. 4



THROTTLE

The speed of the Magnum X is controlled by an automatic return twist grip on the right control group. To accelerate twist the throttle towards you; to decelerate slowly release. The play of the throttle is correct if the cover of the cable allows to be pulled out from the carburetor approx. 0.08 in. (2 mm, fig. 3) by hand, without lifting the throttle piston, i. e. before the engine starts running faster.

ENGINE KILL BUTTON

The engine kill button is located on the left side of the control group (fig. 4). The engine is stopped by pressing this control button.

CAUTION

Be alert when riding on wet or sandy surfaces. Loss of traction between the tire and the riding surface can be expected under these conditions. Be careful when braking, turning or accelerating under adverse conditions.

FUEL VALVE

The fuel valve is located on the right side engine shroud/chain guard. The positions of the fuel valve are On, Off, Reserve as found in the controls section of this manual. The capacity of the tank is 0,93 US gal. (3,5 liters). In the event you should run out of fuel, the reserve position should usually give you adequate range to get back to civilization. Always turn the fuel valve to the "OFF" position when the machine is not in use.

CARBURETOR

The carburetor used on the Magnum X is a Bing 17 mm. The choke, primer, and idle adjustment screw are on the right side of the carburetor for easy access.

Component parts of the carburetor see fig. 11, page 27.

SIDE STAND

The side stand is located on the left and is to be folded down when the machine is not in use.

HANDLEBAR AND CONTROL CABLES

The position of the handlebar is adjusted by the rider himself as per requirement. (For proper adjustment see page 16). After any adjustment to the handlebar check controls and position of control cables and correct if necessary.

IGNITION

The Magnum X is equipped with a Bosch breaker point ignition.

If readjustment is necessary refer to the Magnum X Repair and Parts Manual.



Fig. 5



Fig. 6

FILLING UP WITH TWO STROKE MIXTURE

CAUTION

Gas/oil mixture

DO NOT USE UNLEADED GASOLINE

The Magnum X engine must be run with a gas/oil mixture (regular gas). The recommended mixing ratio is 50:1 when using special Maxi Mix two stroke moped oil. If another oil used please refer to the fuel mixing chart.

WARNING

When re-fueling, have the engine shut down and keep away two things: fire and children.

PUCH MAXI MIX

50 : 1 OIL MIXING TABLE

To 5 gallons gasoline add 12 oz. (355 cc's) oil

To 1 gallon gasoline add 2,4 oz. (71 cc's) oil

To 1 quart gasoline add 0,6 oz. (18 cc's) oil

NOTE

To reduce carbon build-up within your engine and exhaust system, we strongly recommend the use of the special 2 stroke (MAXI MIX) oil. 50:1 ratio. However as an emergency measure, a regular 2 stroke oil can be mixed in a 25:1 ratio as shown below.

25 : 1 OIL MIXING TABLE (REGULAR TWO STROKE OIL)

To 5 gallons of gasoline add 25,6 oz. (757 cc's) oil

To 1 gallon of gasoline add 5,1 oz. (151 cc's) oil

To 1 quart of gasoline add 1,3 oz. (38 cc's) oil

STARTING

Open fuel valve (see fig. 7).

If the engine is cold, depress the choke and primer button on the carburetor (fig. 8). Kick down smartly on starting lever.

CAUTION

After the above is completed do not open the throttle completely as this will deactivate the choke. After the engine is started the throttle should be gently opened as the engine warms, to the full throttle position. This will ensure that the choke will be completely disengaged.

RIDING

WARNING

The machine is equipped with Moto-Cross tires, which have a knobby tread. These tires are intended for use off public highways only.

STOPPING

If you want to stop the machine, throttle down and apply front and rear brake simultaneously. If you apply only one brake, the machine is liable to skid.

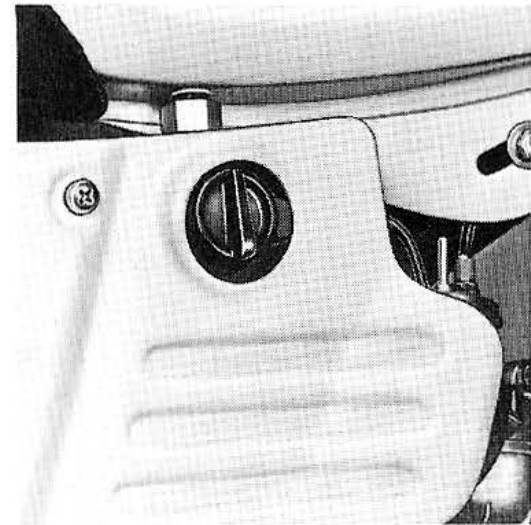
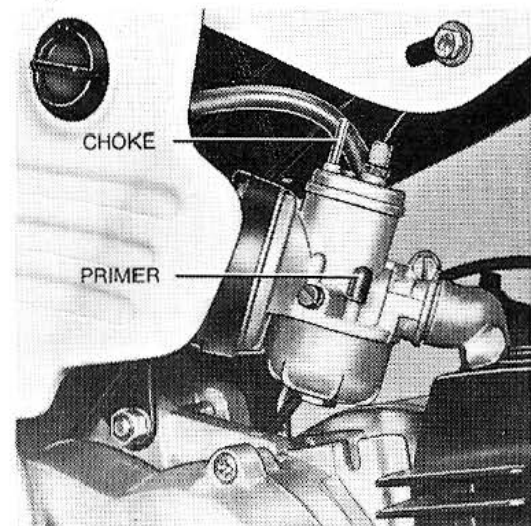

Fig. 7

Fig. 8



BREAK-IN INSTRUCTIONS

CAUTION

In order to prolong the life of the machine a certain running-in period is necessary. Since the machine has been designed for off-the-road operation, it will also be run in off the road. Within the first hours of operation the various parts of the machine are worn to such a degree that they have the ideal clearance. In order to guarantee a proper running-in do not ride on full throttle right from the beginning, as the engine will be overheated. Increase the stress on the engine only gradually and throttle entirely down for short intervals. Within the first hour of operation ride on half opened throttle, within the 2nd and 3rd hour open throttle fully only for short durations. Careful handling of the vehicle during the running-in period will prolong the life and increase the power of the machine.

DECARBONIZING THE ENGINE (fig. 9)

NOTE

The combustion deposits on cylinder head, piston head and exhaust port are in the long run a source of trouble, and must therefore be removed from time to time.

CYLINDER HEAD AND PISTON HEAD

NOTE

Use a blunt edged instrument to remove the carbon deposits so that the surfaces of the parts are not scratched. Every new scratch furthers the deposit of new carbon residues. Remove only the scaly spreading deposits from the piston head, a fine, even layer of oil carbon need not be removed.

Before refitting the cylinder head, remove all carbon deposits from inner side of cylinder thoroughly and apply a thin coat of motor oil. Then by turning the crankshaft over a few times make sure that the engine runs easily. Wipe sealing surfaces on cylinder and cylinder head clean.

Refit cylinder head on to cylinder (with gasket) and the arrow pointing toward exhaust. Tighten the four cylinder head nuts crosswise to 7 ft/lbs.

EXHAUST PORT

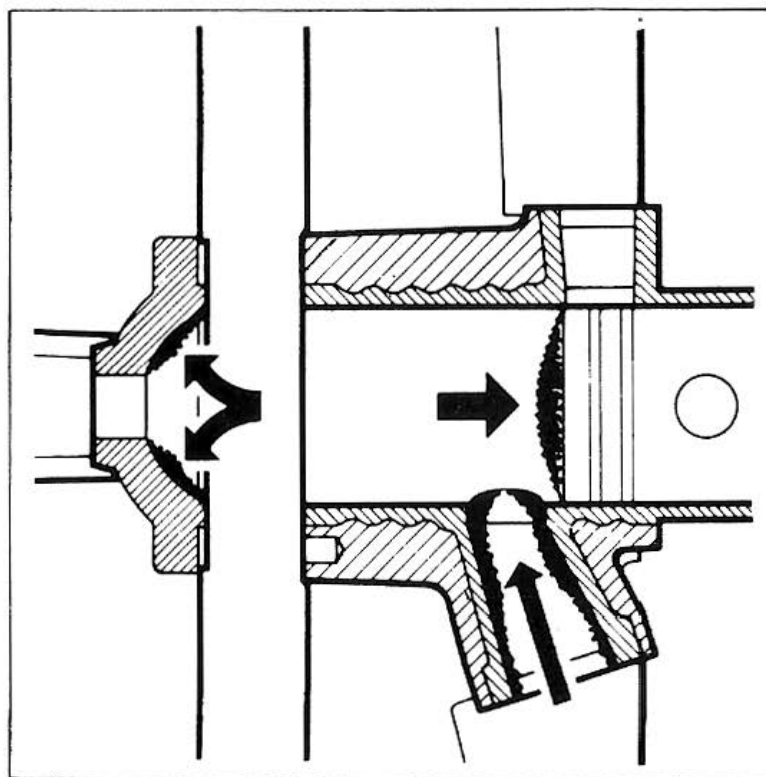

Fig. 9

CAUTION

Remove the exhaust. Turn engine over by means of kickstarter (spark plug removed) until piston reaches lowest point. Carefully remove oil carbon from the exhaust port taking care not to damage piston or cylinder working surface.

CHECKING AND CLEANING THE SPARK PLUG

Screw the spark plug out of the cylinder and ground it at its threaded end e.g. the cylinder head (plug still being connected with the High Tension cable). If the engine is kicked over as in starting, a powerful spark should flash over between the electrodes.

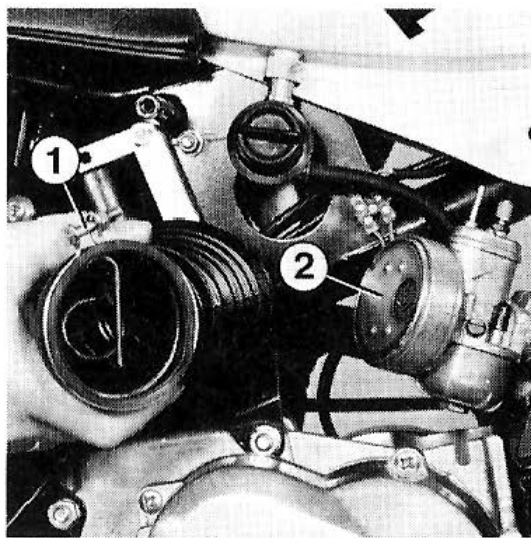

Fig. 10

WARNING

Be sure no gasoline or flammable residue is on cylinder head or engine.

Oily plugs or plugs with dirt deposits between the electrodes will not produce any spark and must be cleaned with a wooden splinter or wire brush. The spark gap should be .0157—.0197 in. (0,4—0,5 mm). If the gap is wider regap by bending the outer electrode. When screwing in the plug take care that it fits into the thread properly and can be turned easily. Never screw in with force: First screw in by hand — 2 or 3 turns — then use the spark plug wrench.

When replacing the spark plug use only plugs with long thread and the specified thermal value. (See technical data)

CLEANING THE AIR FILTER

Remove fixing screws from the right side engine shroud. Loosen clamping bracket of rubber boot (fig. 10/1) and remove rubber boot. Pull filter disc (fig. 10/2) out of carburetor. Clean metal air filter with gasoline or similar cleaning material, blow completely dry with compressed air and spray filter element lightly with engine oil.

Replacing see page 18.

NOTE

If the Magnum X is ridden in extremely dusty areas the air filter should be serviced at more frequent intervals.

STRIPPING AND CLEANING THE CARBURETOR

CAUTION

The carburetor fitted to the engine is tuned to specifications established by intensive factory research and should not be altered in any way. Whenever dismantling a carburetor, clean all components with gasoline and blow off with compressed air. Ensure that seating of the inlet needle is correct.

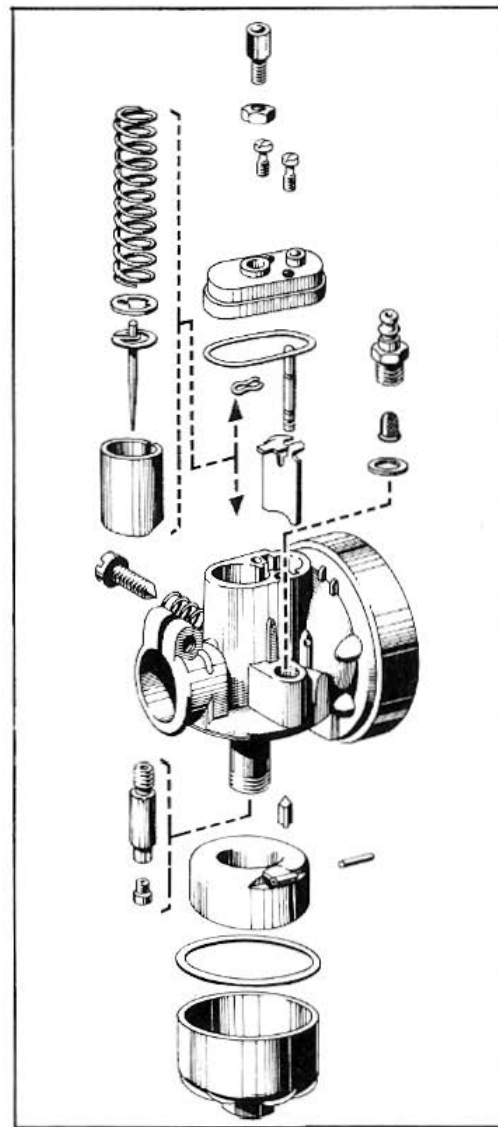

Fig. 11

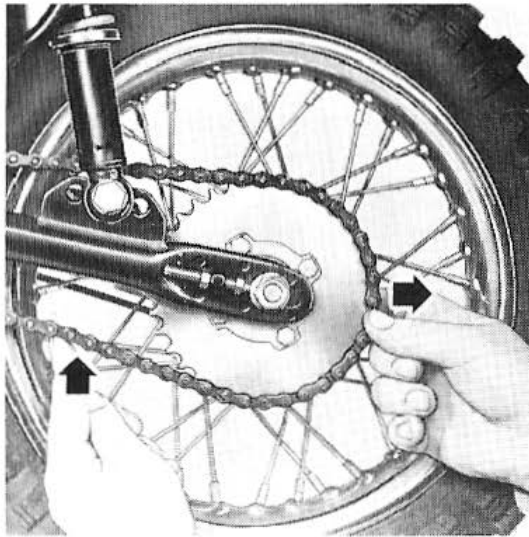
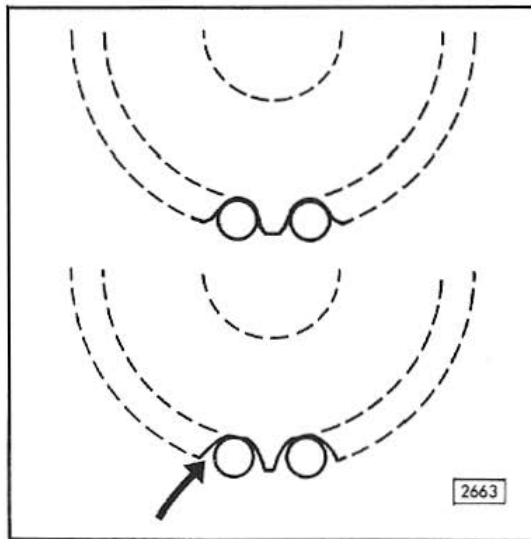

Fig. 12

Fig. 13



CHECKING THE CHAIN AND SPROCKETS FOR WEAR

CAUTION

The most simple method to find out whether the chain can still be used is shown in fig 12. Press the chain by hand upwards so that it is tightly tensioned. If now the chain permits to be lifted from the sprocket by the other hand by more than half the diameter of the roller, the chain must be replaced. If the sprockets are worn as shown in figure 13 have them just as well replaced. When installing the chain make sure that the chain master link is in the proper position i.e. with the closed part in the direction the chain moves.

NOTE

If the Magnum X is ridden in extremely dusty areas the drive chain should be serviced at more frequent intervals.

LUBRICATING THE CHAIN

CAUTION

The life of a chain depends greatly on the maintenance. Therefore clean and lubricate it repeatedly. Never ride with a dry chain! A badly soiled chain must be cleaned and washed in kerosine.

CHANGING THE TRANSMISSION FLUID

CAUTION

Warm engine up. Remove fluid level checking screw (fig. 14/1) and drain screw (fig. 14/2). Incline machine somewhat to the right so that the fluid may escape entirely. Through the filler hole (fig. 14/3) fill approx. 7,44 US-oz.fl. (220 cc) of Automatic Transmission Fluid (Type "F" only). If the fluid level is correct, refit checking screw and filler plug. At any oil change clean oil drain plug from metal chips.

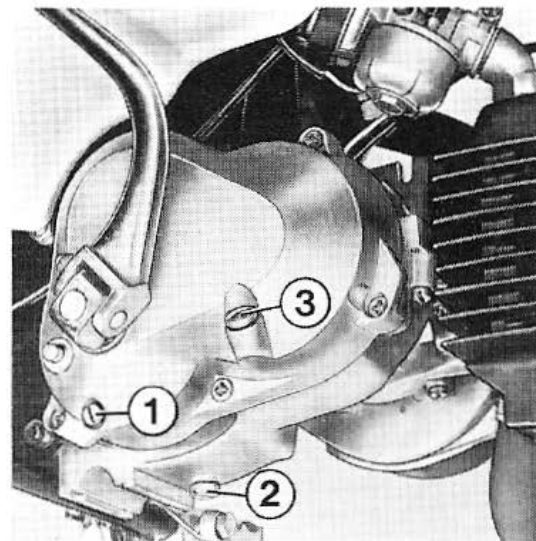
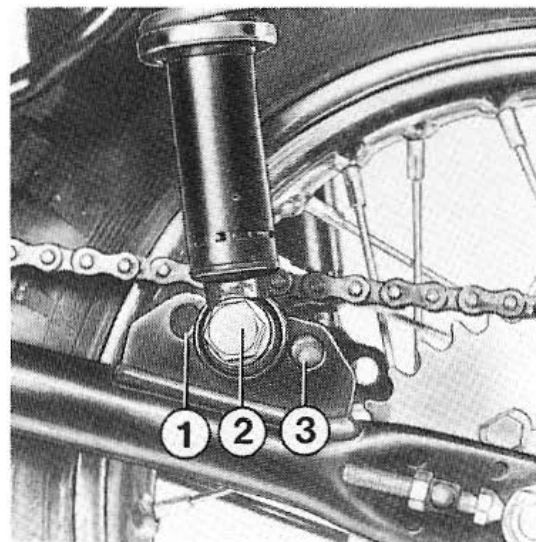

Fig. 15

Fig. 14

SHOCK ABSORBERS

Shock absorbers on the Magnum X are not serviceable. Faulty suspension units must be replaced. Only the upper and lower rubber mountings and bearing bushes are available. The three lower mounting positions indicate softer or harder rear suspension. Position (1) indicates harder riding suspension, position (2) medium (or normal riding) and position (3) gives a softer riding suspension.



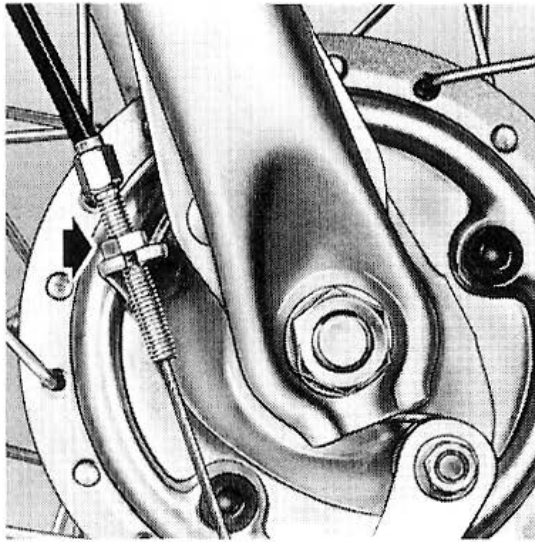

Fig. 16

LUBRICATING CHASSIS PARTS

NOTE

With oil:
Cable adjuster at the
brake cover plate of the
front wheel (fig. 16).
Cable adjuster at the rear
wheel brake (fig. 17).

Chain adjuster (fig. 17).

Side stand bearing (fig. 18).

Bearing of the foot rests
(fig. 19).

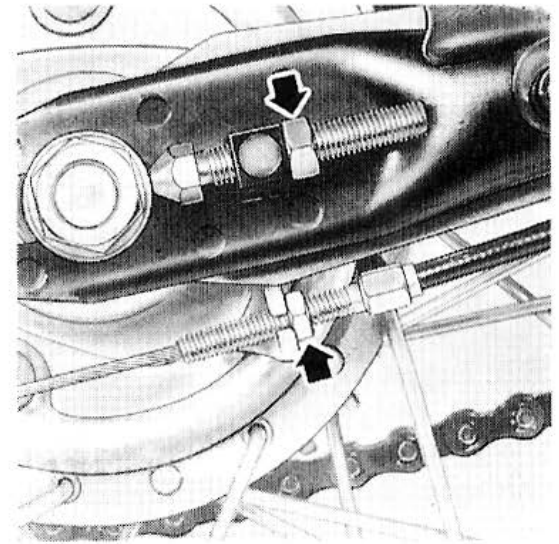

Fig. 17

Fig. 19

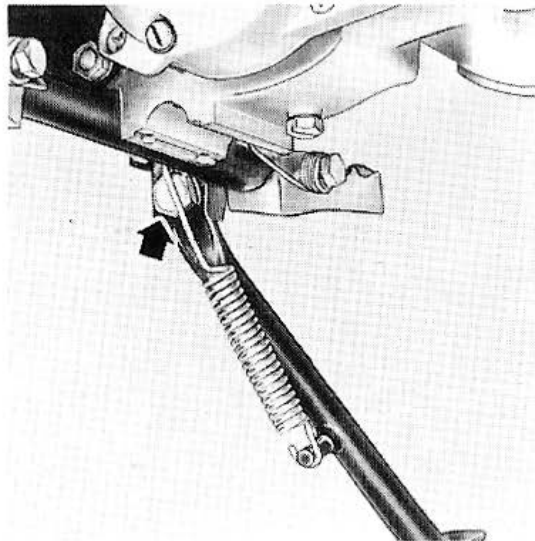
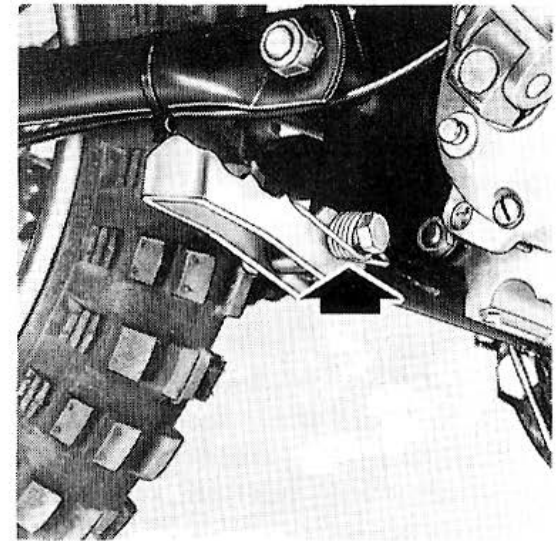

Fig. 18



REMOVING THE FRONT WHEEL

WARNING

Undo flexible speedo shaft at the speedometer drive. (Hub end) fig. 20/1.

Remove cable adjuster (fig. 21/1) and disengage brake cable. Unscrew both axle nuts (fig. 20/2 and 21/2).
Remove the wheel.

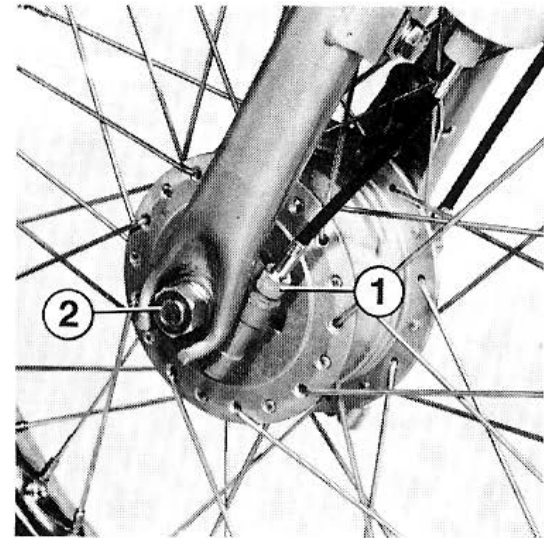
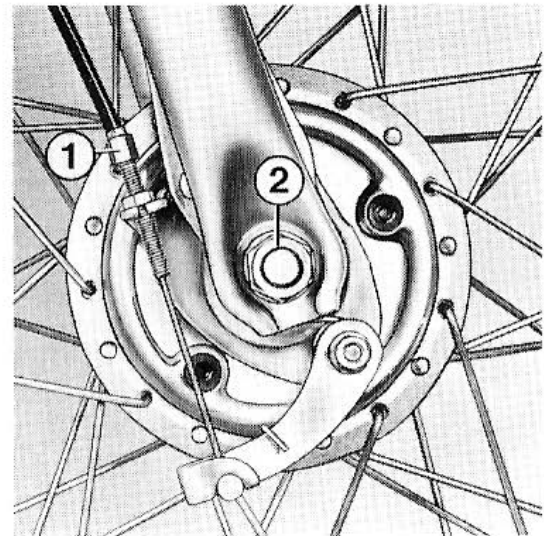

Fig. 20

Fig. 21



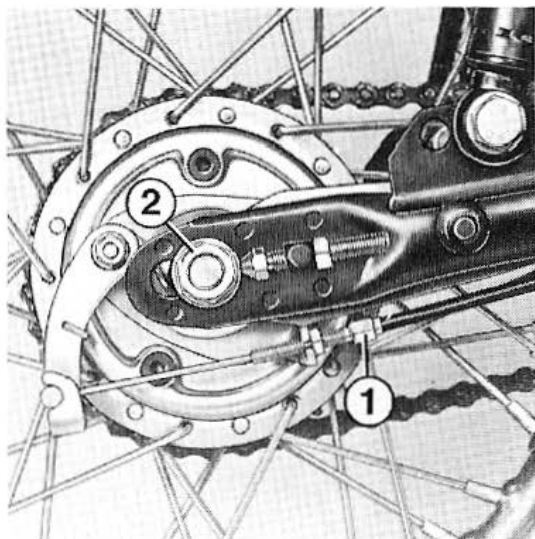
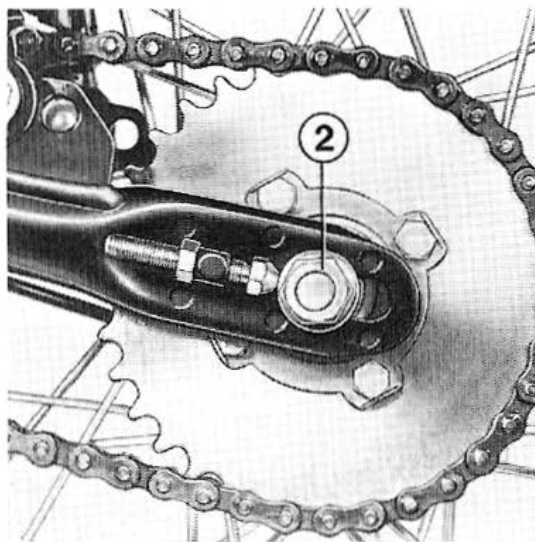

Fig. 22

Fig. 23



REMOVING THE REAR WHEEL

WARNING

Loosen brake adjusting nut and disengage brake cable (fig. 22/1). Remove both axle nuts and remove axle (fig. 22/2 and 23/2). Install wheel and axle in the reverse procedure to dismantling.

7 LUBRICATING AND MAINTENANCE CHART

The following periodic maintenance can be carried out at home.

Pre-riding check list	After 300 mi. (20 hours)	After 600 mi. (40 hours)	Job Description
●	●	●	Check front and rear wheel brake, adjust if necessary
—	●	●	Check spark plug and clean
—	—	●	Clean carburetor, fuel cocks and fuel lines
●	●	●	Check air cleaner, clean if necessary
●	●	●	Check chain tension
—	●	●	Lubricate chain
—	—	●	Check the chain and sprockets for wear
●	●	●	Check cables
—	●	●	Grease chassis parts
—	●	●	Check transmission oil level
●	●	●	Check bolts and nuts for tightness*)
●	●	●	Check tire pressure
●	●	●	Check position of inflation valves
●	●	●	Check wheels and tires, spokes for tightness
—	—	●	Check steering bearing
—	—	●	Decarbonize the engine
—	—	●	Decarbonize exhaust
—	—	●	Check hub bearings, replace if necessary
—	●	●	Check oil in transmission

*) Retighten cylinder head nuts every 5 operating hours.

8 WIRING DIAGRAM

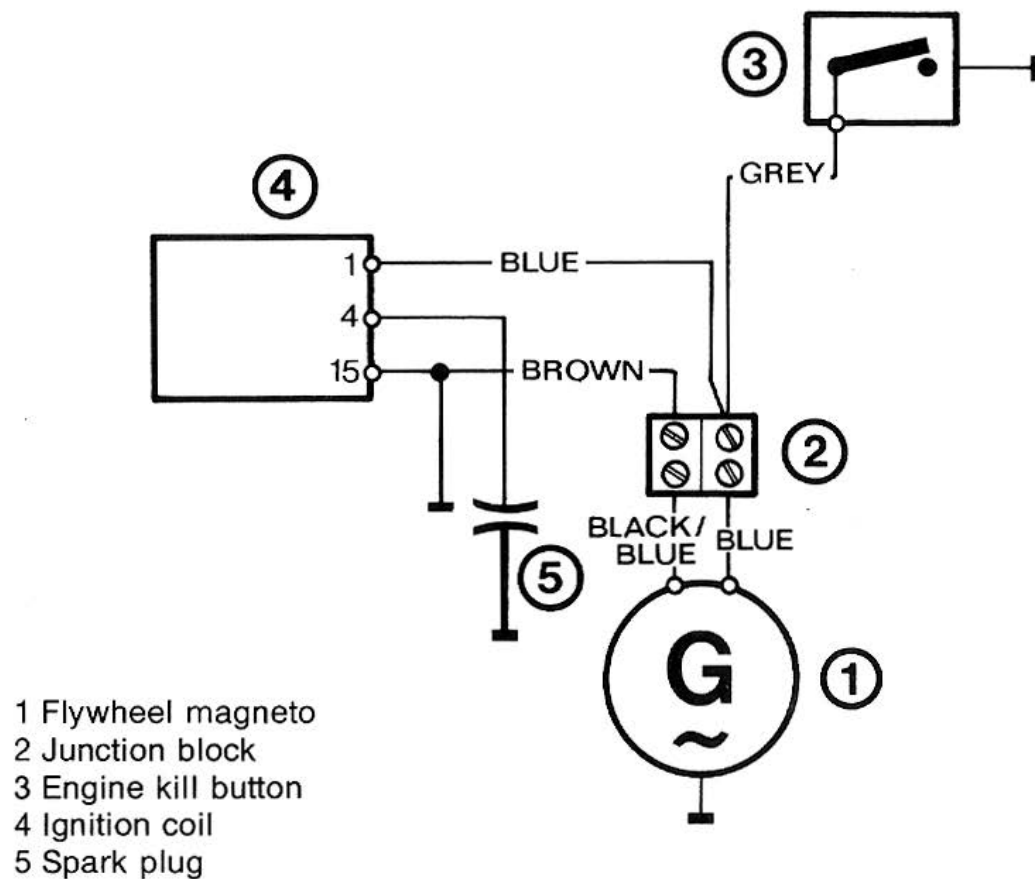

PUCHPUCHPUCHPUCHPUCHPUCHPUCHPUCHPUCHPUCHPUCHPUCH

Steyr Daimler Puch of America Corporation

907.1.71.926.1 0179
Printed in Austria