

Chapter 1
Electrical systems
Two Stroke Auto engines

1

1. 50 & 80cc Charging, early type
2. 50 & 80cc Charging, later type
- 2a. NRG / Zip Cat Charging & Gauges
3. 50 & 80cc Ignition
4. 125 & 180cc Charging / Ignition
5. 125 & 180cc Indicator circuits
6. 125 & 180cc Ignition
7. Runner 125 / 180 2t Fuses
8. Diosis 100 Ignition / Charging
9. Purejet 50 Charging / Ignition
10. Purejet 50 Indicators / Oil check

Chapter 2

Electrical Systems

Vehicles with LEADER Engines

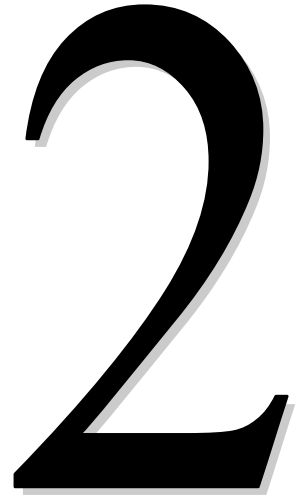

1. B125 / 200 Ignition / Charging
2. B125 Notes
3. B125 Fuse Explanation
4. DNA 125 / 180 Ign. / Charging
5. DNA 125 / 180 Switch Wiring
6. ET4 125 Ignition / Charging
7. Hexagon GTX Ign. / Charging
8. Runner VX / VXR Ign. / Charging
9. X9 125 / 180 Ignition / Charging
10. Zip 125 Ignition / Charging
11. General Notes
12. Immobiliser Notes
13. Vespa GT 125 / 200 Ignition / Charging
14. Vespa GT 125 / 200 Fuses

3

Chapter 3

Electrical Systems

Four Stroke (Non Leader)

1. Coguar 125 Ignition / Charging
2. ET4 (ZAPM04) Early Charging
3. ET4 (ZAPM04) Late Charging
4. ET4 (ZAPM04) Immobiliser Notes
5. Hexagon GTX 250 Ign./ Charging
6. Liberty 125(non Leader) Charging
7. X9 250 Ignition / Charging
8. X9 250 Notes
9. X9 250 Fuse Explanation
10. 50cc 4 stroke Ignition / Charging
11. 50cc 4 stroke Restriction Notes

Chapter 4
Electrical Systems
Two Stroke
Manual Engines

4

1. H@k / GSM Ignition / Charging
2. H@K / GSM Notes
3. H@K / GSM Wiring Diagram
4. Vespa PX Ignition / Charging
5. Vespa PX Start Permissive Circuit
6. Vespa PX Indicator Circuit
7. Vespa T5 Horn circuit
8. Gilera RCR 50 Ignition / Charging

Chapter 5
Electrical Systems
General

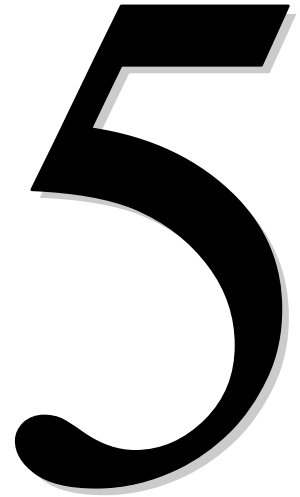

1. X9 Range General Notes
2. X9 Range. Under the front Panel
3. Stator Coil Values - Quick Ref.
4. Auto Choke Operation
5. Fuel Gauge Circuit
6. Digital Instrument Display Notes

Chapter 6

Fuel Systems



1. Typhoon 80 / 125 Fuel System
2. DNA Fuel Systems
3. Hexagon (EXS1T) Fuel System
4. Pumped Fuel Systems
5. Vespa PX Fuel Tap

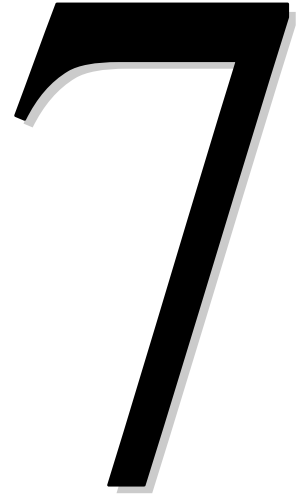

Chapter 7

Mechanical Systems

1. Fitting Main Bearings. All 2t autos.
2. Vespa PX Clutch assy.
3. Piston & Small End Sizes
4. Up Side Down Forks
5. Spark Plug List
6. Oil List
7. Tyres / Wheels Piaggio
8. Tyres / Wheels Gilera
9. Keys Gilera
10. Keys General
11. Alarm Fitment List
12. De-Restriction Notes
13. Chassis Number Location
14. Quick Reference Guide
15. Service Limit List

Purejet 50 Turn Signals & Oil check

Piaggio Ltd.

02/05/2003

Runner

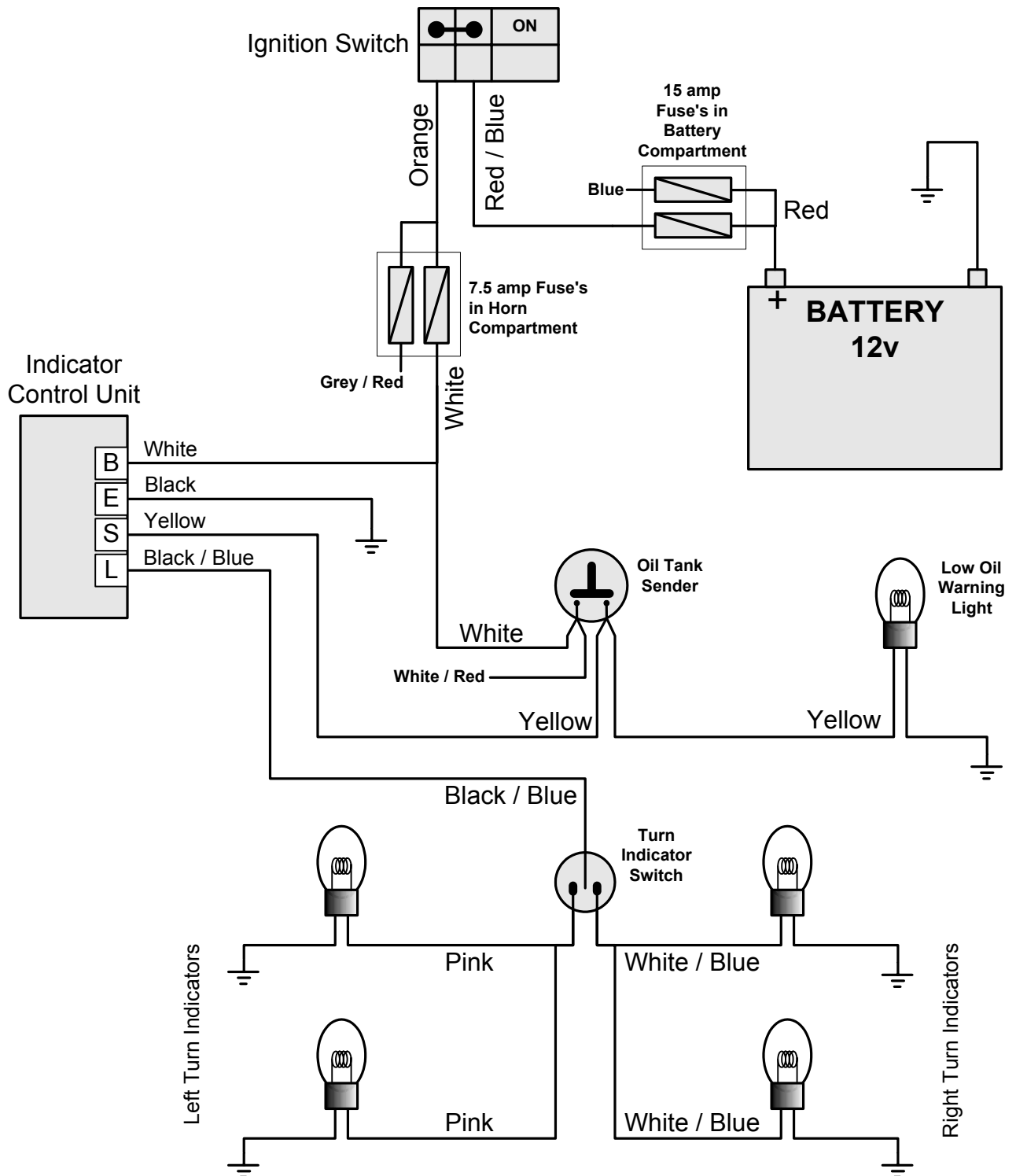

- * The low oil warning light check function is controlled by the indicator relay.
- * The oil check light should come on for 15 seconds when the ignition is first turned on.
- * If the system fails: first check the 7.5 amp fuse located under the front grill (horn) panel.

DIESIS 100 Charging / Ignition

Piaggio Ltd.

11/06/02

Derbi engine

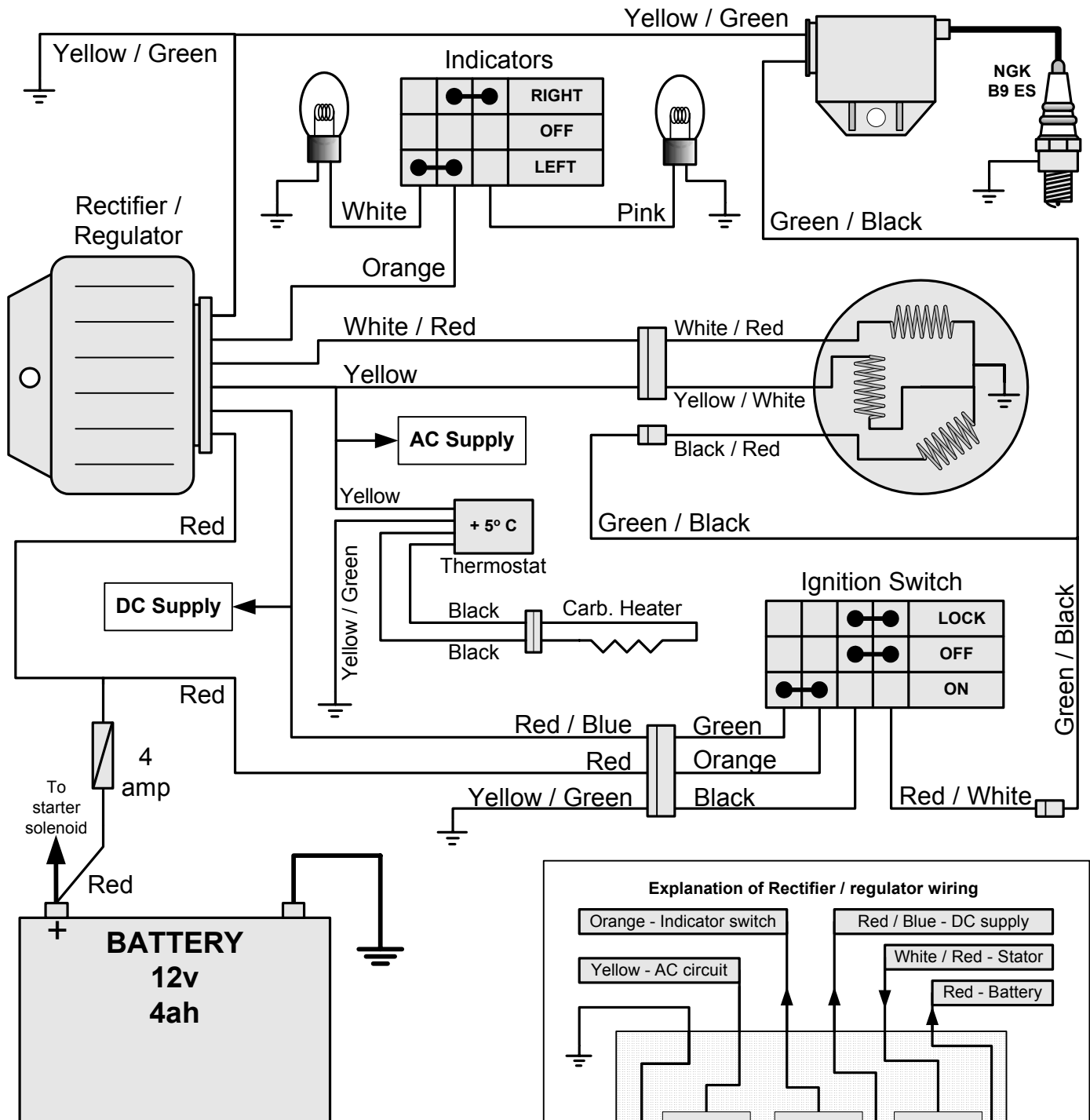

Earth wires are - Yellow / green.
 Yellow wire is AC supply.
 Red / Blue wire is DC supply.
 Engine earth is very important.
 Carb heater is driven by AC power via a thermostat.
 No separate Ignition pick up, CDI is triggered by the AC wave.
 Ignition is earthed to stop the engine.

TESTS.

Stator: Yellow - Earth = min 25 v AC. White / Red - Earth = min 30 v AC. Engine at mid rpm.
 Yellow - Earth = 0.9 ohm ± 0.2. White / Red - Earth = 1.1ohm ± 0.2. Stator un-plugged.
 Black / Red - Earth = 238 ohm ± 10%. Stator un-plugged.
 Regulator: Yellow - Earth = 13.5 ± 0.5 v AC. White / Red - Earth = 13.5 ± 1.0 v DC. Engine at mid rpm.
 Ignition: HT coil secondary resistance = 5 - 6 K ohm. Unit un-plugged.

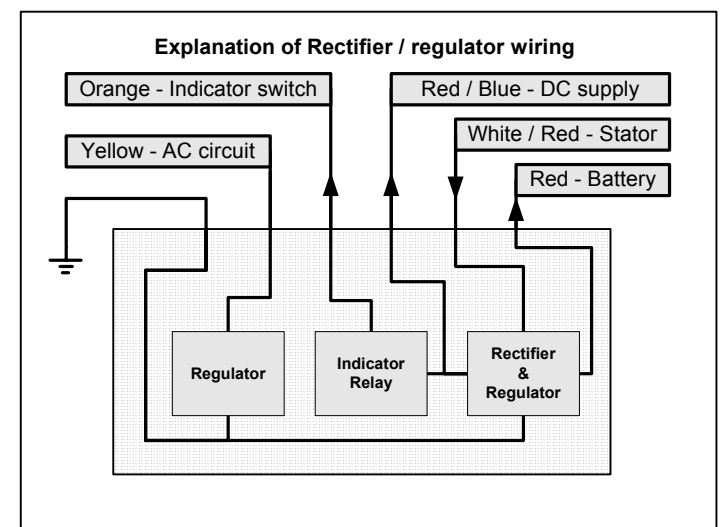

FUSE EXPLANATION

Runner FX 125 & FXR 180

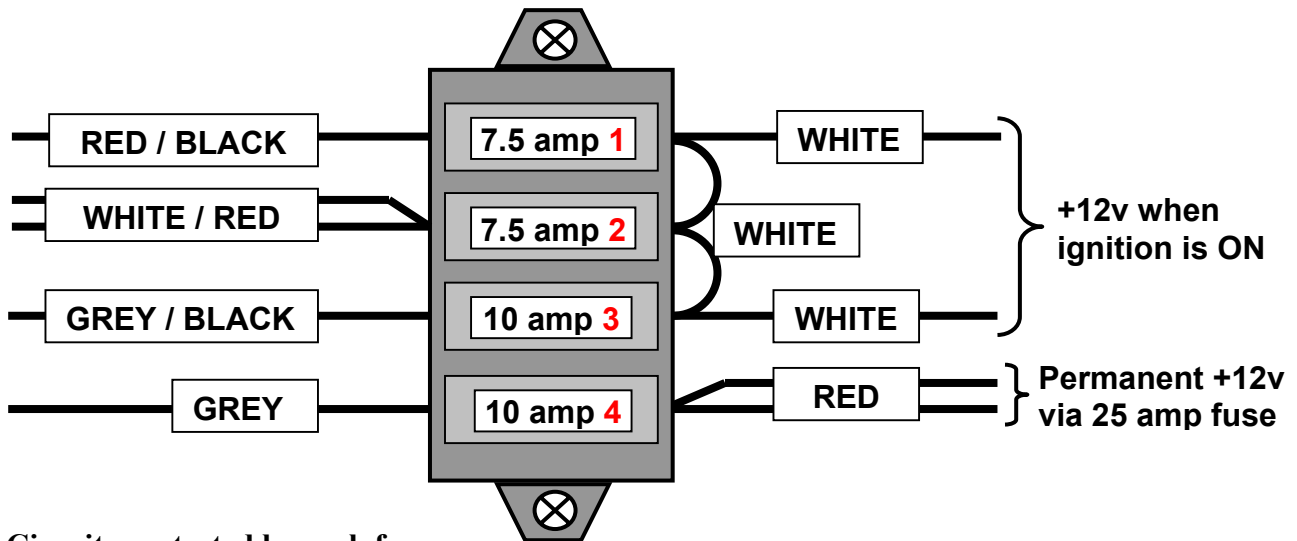

Circuits protected by each fuse.

1. Head light flash (passing light).
2. Indicators. Brake light. Oil indicator. Electric start relay. Temp gauge. Fuel gauge. Horn. Choke.
3. Headlight relay. Town light. Rear light (lighting switch)
4. Both headlights (power)

Notes.

- Ignition circuit is completely separate and self powered. It does not have any fuses.
- The cooling fan is permanently live and is protected by the main 25 amp fuse.
- The starter motor supply is not fused.

Relation between lighting and the fuses.

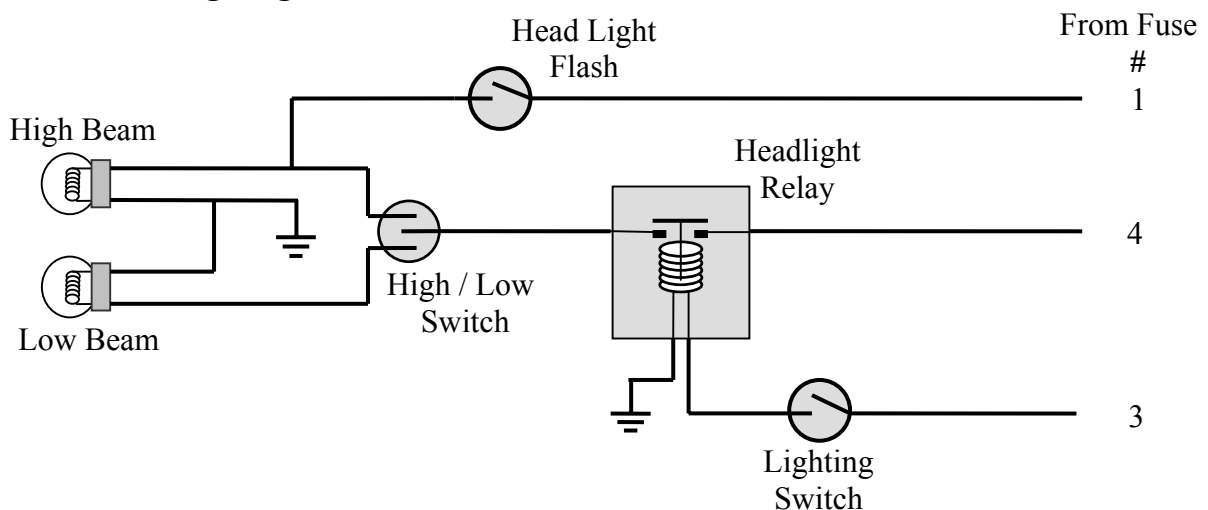

125 / 180 2T Ignition

Piaggio Ltd.

23/01/2003

Hexagon LX / LXT
 Runner FX / FXR
 Skipper & Typhoon 125

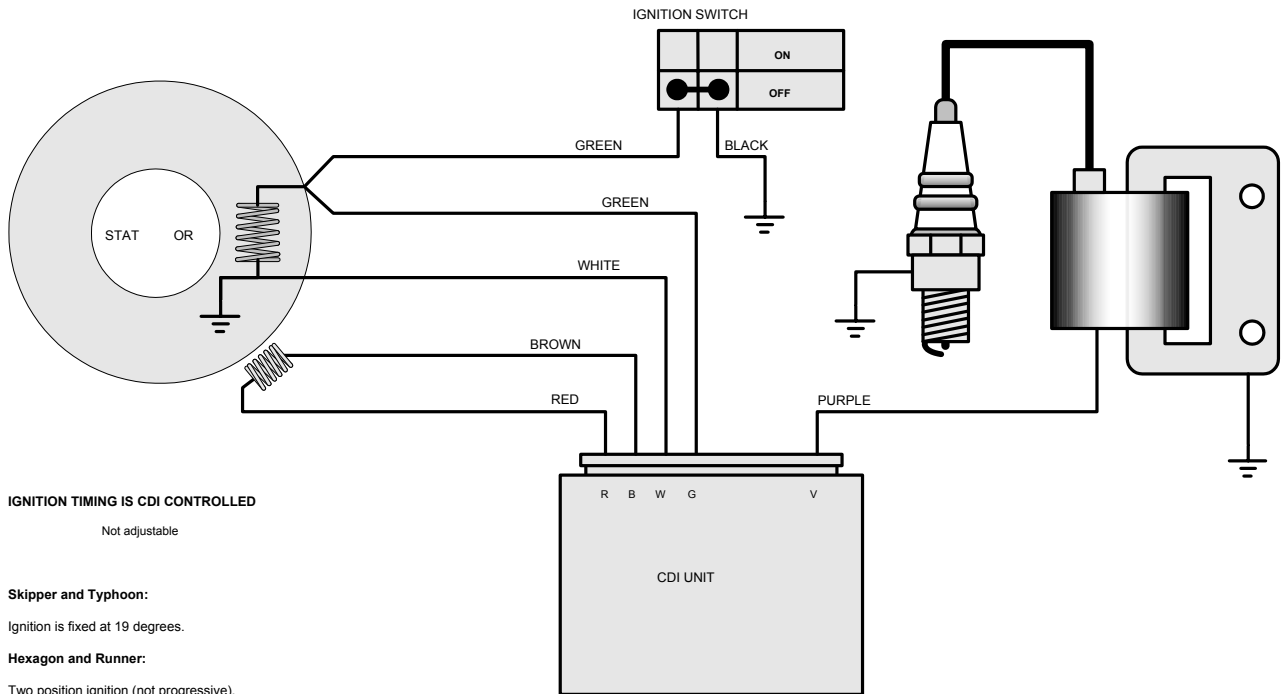

IGNITION TIMING IS CDI CONTROLLED

Not adjustable

Skipper and Typhoon:

Ignition is fixed at 19 degrees.

Hexagon and Runner:

Two position ignition (not progressive).

9 deg @ 1500+ rpm. Then 22 deg @ 7500+

STATOR TEST VALUES.

Stator un-plugged

Meter between >	Red - Brown	White - Green	Purple - Earth	HT lead - Earth
To test >	Pick - up Coil	Charge Coil	HT Primary	HT Secondary
Hexagon LX / L XT	90 - 140 ohm	50 - 100 ohm	0.5 - 0.025 ohm	4.8 - 0.25 k ohm
Runner FX / F XR	90 - 140 ohm	50 - 100 ohm	0.5 - 0.025 ohm	4.8 - 0.25 k ohm
Skipper / Typhoon 125	90 - 140 ohm	100 - 160 ohm	0.5 - 0.025 ohm	4.8 - 0.25 k ohm

NOTES.

* The ignition circuit is a separate self-contained circuit with no fuses and no connection to the other electrical circuits on the vehicle. It has a separate charging coil in the stator (Green & White wires).

* The ignition switch contacts are OPEN when the engine is RUNNING. Contacts are CLOSED when switch is turned OFF, this allows the system to discharge to earth. When fault finding, if there is no spark then check the "green" and "purple" wires to see if there is a "leak" to earth. Unplug stator & CDI, check green to earth: Ignition on = no continuity. Ignition off = continuity.

* A "Resistor" type spark plug and a resistor plug cap should always be fitted.

* This circuit does not require the engine to chassis earth. But if that earth lead is missing it is possible that trying to use the starter motor could force excess current through the CDI and damage it. Always prove you have a good engine to chassis earth connection.

125 / 180 Two Stroke INDICATOR CIRCUIT

Piaggio Ltd

06/08/2002

Piaggio Ltd

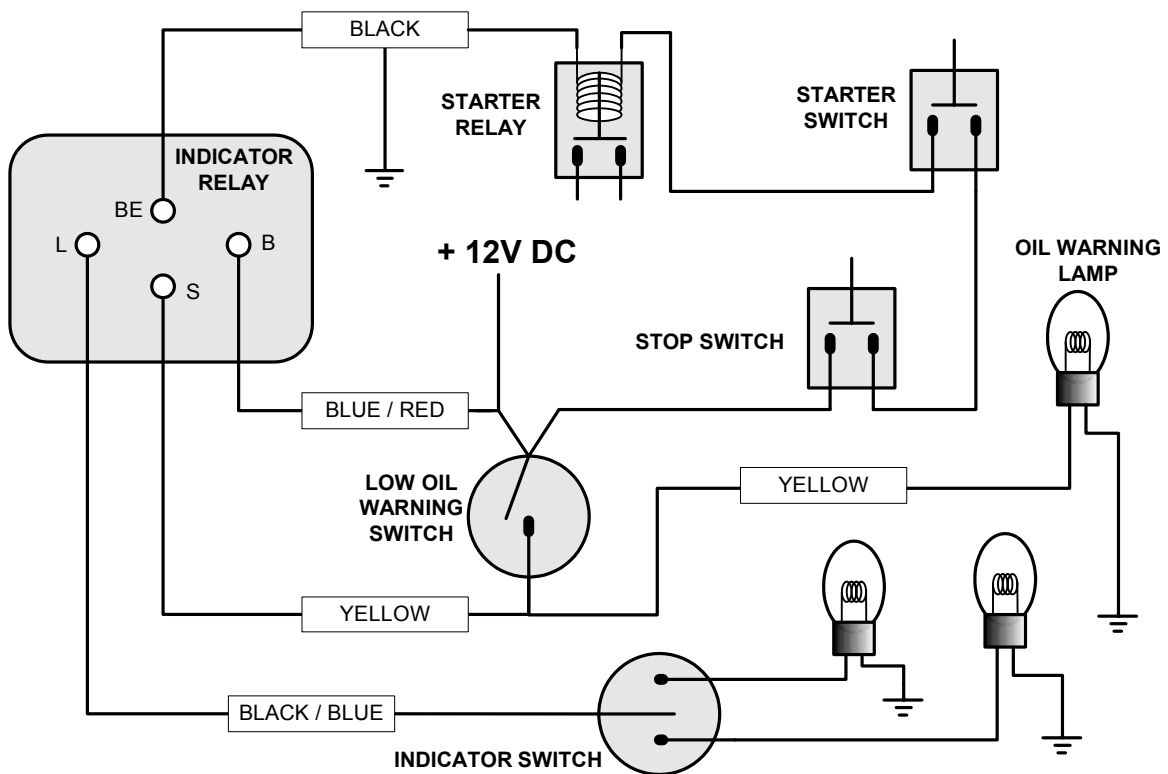

ABOVE. Vehicles 1999> Circuit with oil check light that comes on when ignition is switched on.

Refer to the Service Station Manual. Also Technical Notes 2/99 and 3/99.

BELOW. Vehicles <1999 Circuit with oil check light that comes on when brake is held on and starter button is pressed.

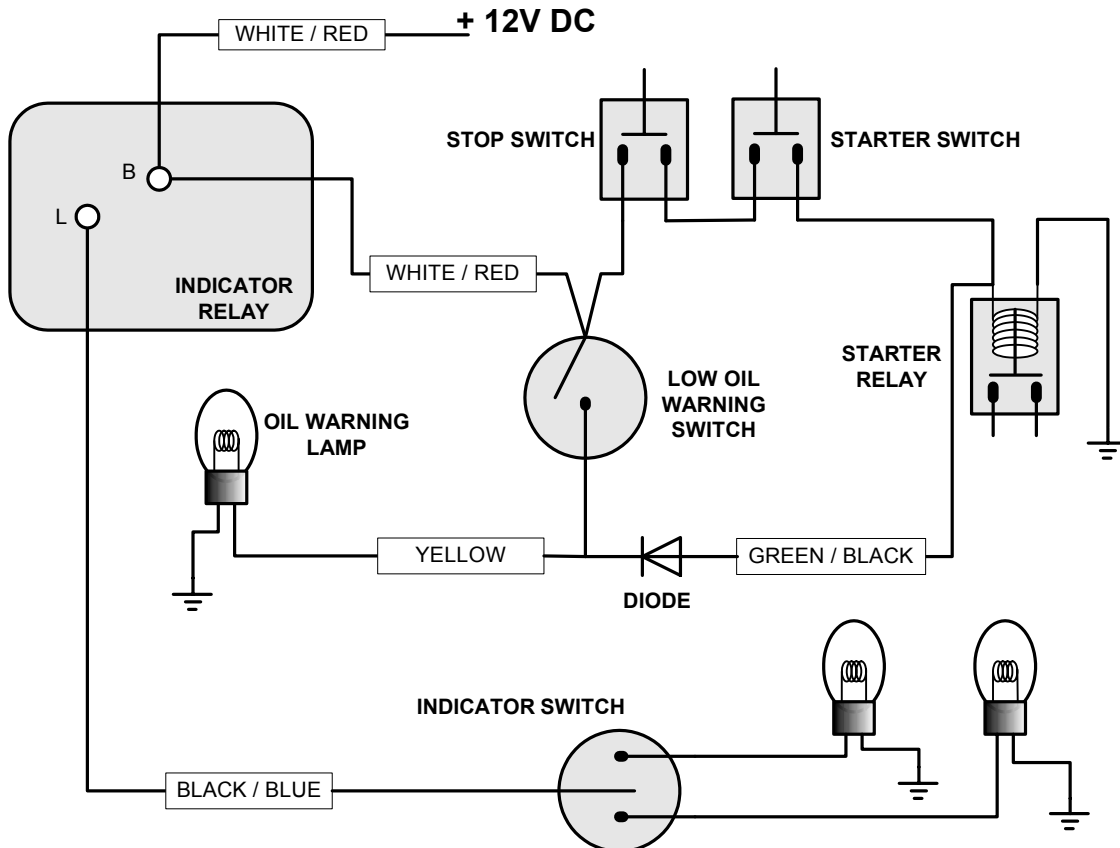

125 & 180cc 2t charging / Ignition

Typhoon, Skipper, Hexagon, Runner

Piaggio Ltd

13/08/2002

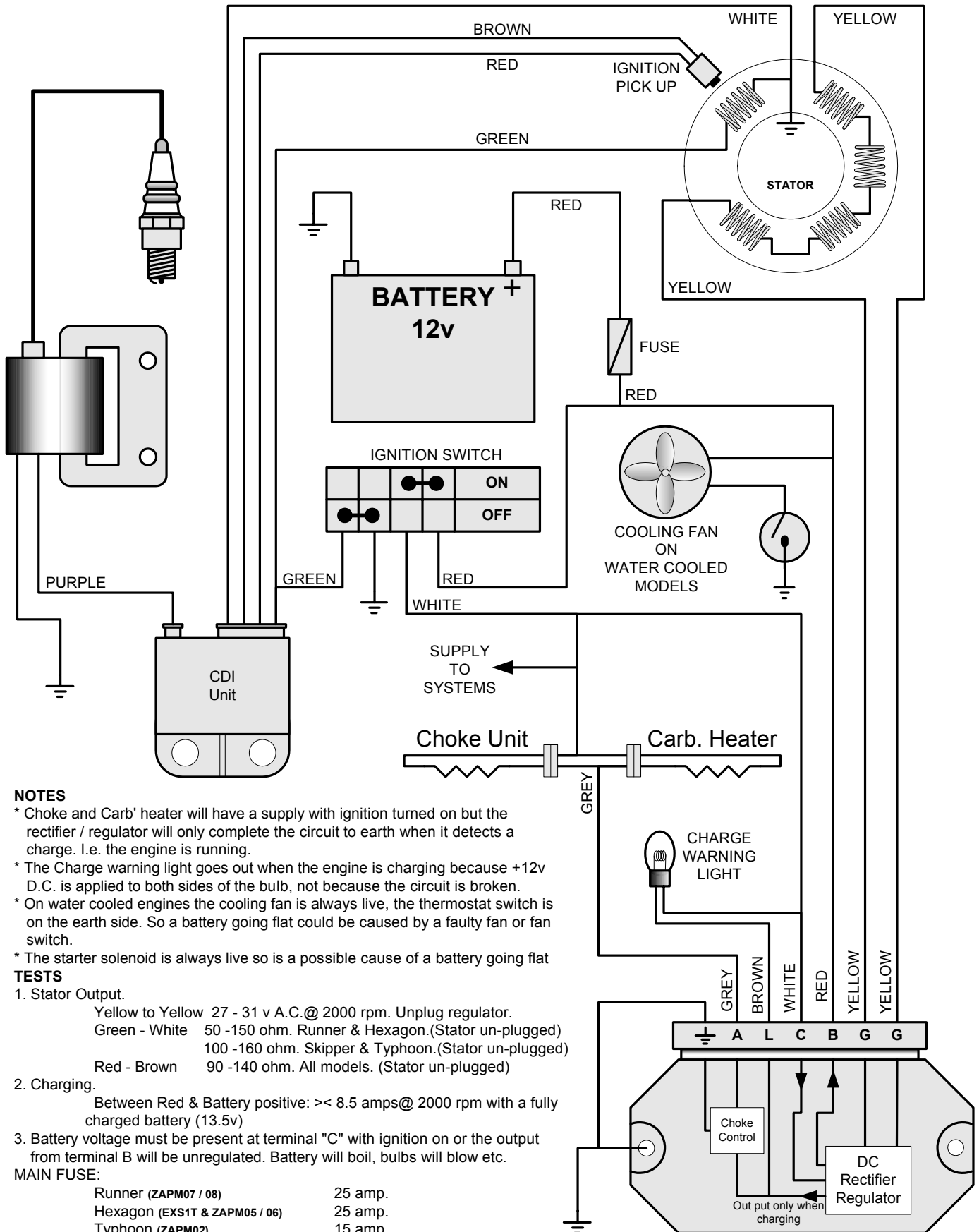

NOTES

- * Choke and Carb' heater will have a supply with ignition turned on but the rectifier / regulator will only complete the circuit to earth when it detects a charge. I.e. the engine is running.
- * The Charge warning light goes out when the engine is charging because +12v D.C. is applied to both sides of the bulb, not because the circuit is broken.
- * On water cooled engines the cooling fan is always live, the thermostat switch is on the earth side. So a battery going flat could be caused by a faulty fan or fan switch.
- * The starter solenoid is always live so is a possible cause of a battery going flat

TESTS

1. Stator Output.

- Yellow to Yellow 27 - 31 v A.C. @ 2000 rpm. Unplug regulator.
- Green - White 50 - 150 ohm. Runner & Hexagon. (Stator un-plugged)
- 100 - 160 ohm. Skipper & Typhoon. (Stator un-plugged)
- Red - Brown 90 - 140 ohm. All models. (Stator un-plugged)

2. Charging.

Between Red & Battery positive: >> 8.5 amps @ 2000 rpm with a fully charged battery (13.5v)

3. Battery voltage must be present at terminal "C" with ignition on or the output from terminal B will be unregulated. Battery will boil, bulbs will blow etc.

MAIN FUSE:

Runner (ZAPM07 / 08)	25 amp.
Hexagon (EXS1T & ZAPM05 / 06)	25 amp.
Typhoon (ZAPM02)	15 amp.
Skipper (CSM1T)	7.5 amp.

50cc 2t Ignition

Piaggio Ltd

19/07/02

Piaggio Ltd

This circuit could apply to any 50cc two stroke with or without a rev counter

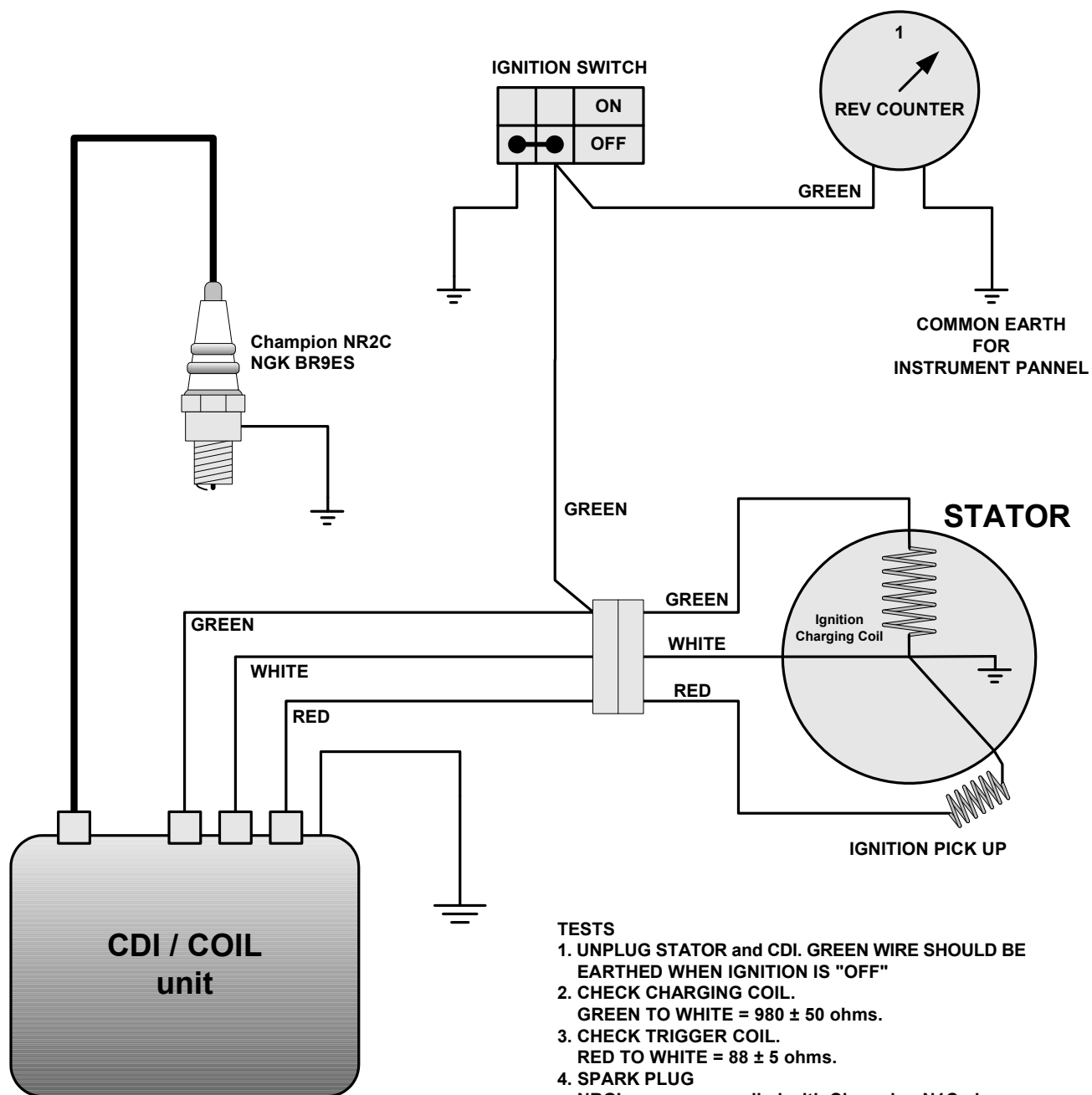

TESTS

1. UNPLUG STATOR and CDI. GREEN WIRE SHOULD BE EARTHED WHEN IGNITION IS "OFF"
2. CHECK CHARGING COIL.
GREEN TO WHITE = 980 ± 50 ohms.
3. CHECK TRIGGER COIL.
RED TO WHITE = 88 ± 5 ohms.

4. SPARK PLUG

NRG's are now supplied with Champion N1C plugs
The NGK equivalent is B10ES.
This plug is very cold running and may not suit all riders.
If you find that a machine is fouling plugs try fitting an NGK B9ES.

NOTES

White wire is a common, dedicated earth.

If the engine earth wire was missing the engine would run but you may have problems with the CDI unit failing because the electrical system may try to use the white wire as its earth connection.

Green wire will have 150-200v AC when engine is running.

NRG & ZIP Cat. Charging & Guages

Piaggio Ltd.

02/05/2003

8 pin regulator

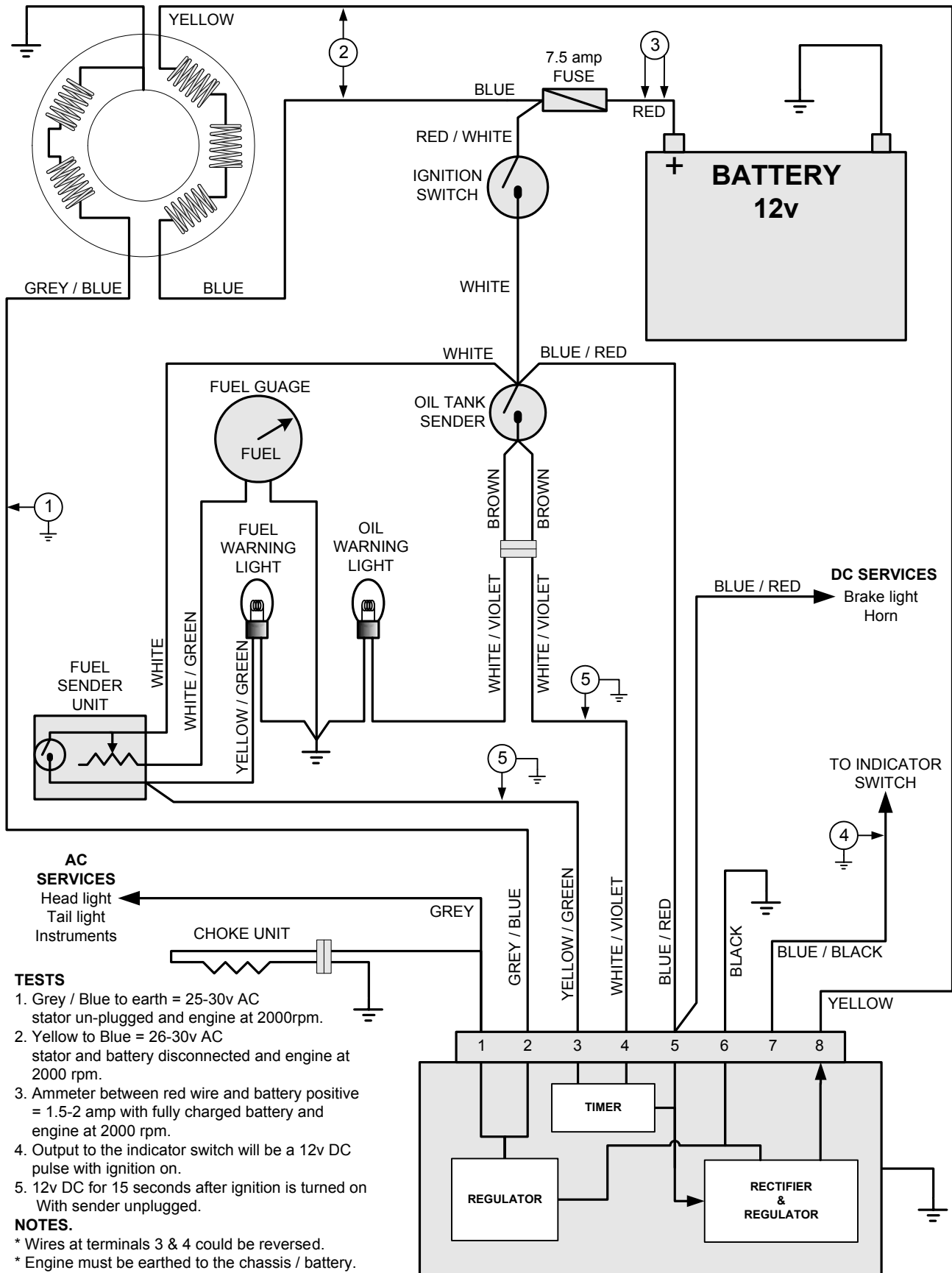

The NRG / Zip Cat wiring is very similar to other 50 / 80 scooters.
Refer to page 2 (50 / 80 Charging) and page 3 (50cc 2t Ignition) for other information.

50 / 80cc 2T charging

Piaggio Ltd.

06/08/2002

8 pin regulator

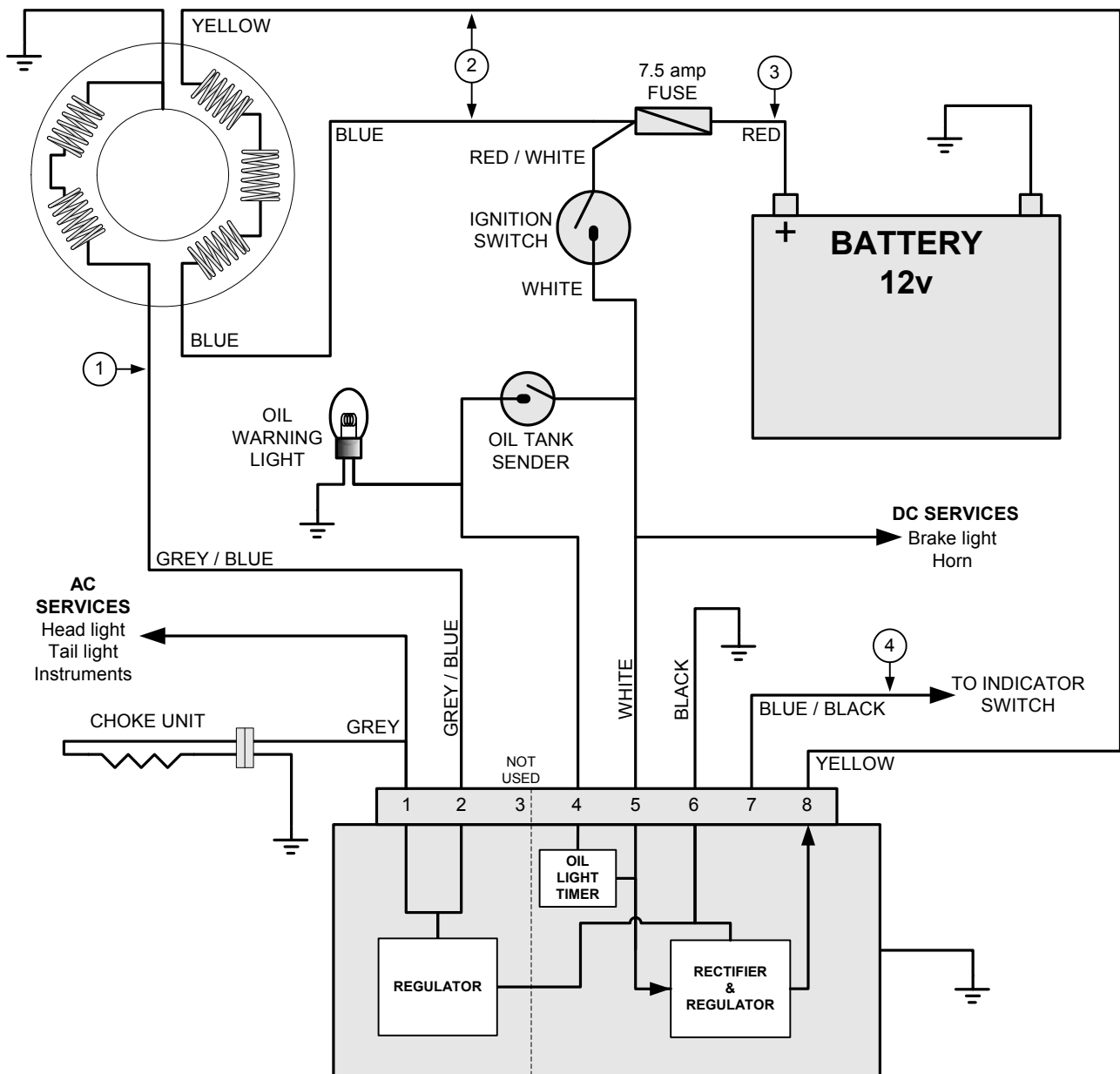

* This diagram shows the later 50cc and 80cc two stroke wiring using an eight pin connector on the rectifier / regulator. Refer to the separate diagram for earlier circuit using a five pin rectifier / regulator.

* **RECOGNISE THIS CIRCUIT:** If the oil warning light comes on for 15 seconds when ignition is turned on.

* Two completely separate circuits for AC & DC.

* Eight pin rectifier / regulator incorporates the indicator relay and oil light check function.

* The choke is supplied with 12v AC when the engine is running .

TESTS.

1. Grey / Blue to earth = 25-30v AC stator un-plugged and engine at 2000rpm.

2. Yellow to Blue = 26-30v AC stator and battery disconnected and engine at 2000 rpm.

3. Ammeter between red wire and battery positive = 1.5-2 amp with fully charged battery and engine at 2000 rpm

4. Output to the indicator switch will be a 12v DC pulse with ignition on.

NOTES.

Engine must be earthed to the chassis / battery. Lack of this connection will affect the AC circuit and starter motor but not the DC circuit or ignition circuit.

50 / 80cc 2T charging

Piaggio Ltd.

02/05/2003

5 pin regulator

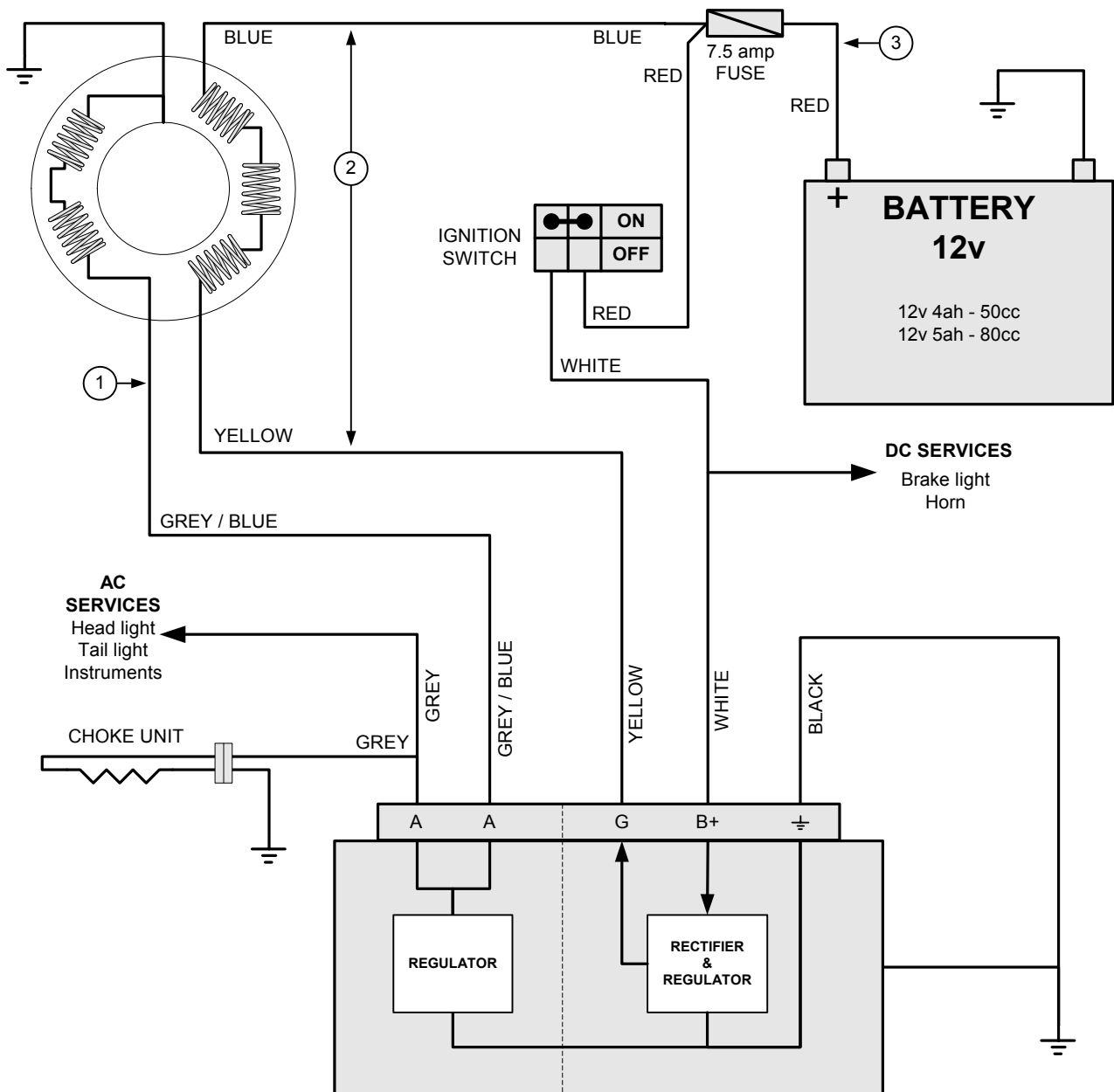

* This diagram shows the early 50cc and 80cc two stroke wiring using a five pin connector on the rectifier / regulator. Refer to the separate diagram for later circuit using an eight pin rectifier / regulator.

* **RECOGNISE THIS CIRCUIT:** If the oil warning light comes on when the starter button is pressed.

* Two completely separate circuits for AC & DC.

AC is full wave and regulated

DC is half wave rectified and regulated

* If voltage at the **B+** terminal falls below 8v (approx) the DC rectifier / regulator will not function so there will be no output from the alternator on the DC circuit.

* Separate indicator relay.

* The choke is supplied with 12v AC when the engine is running .

TESTS.

1. Grey / Blue to earth = 25-30v AC stator un-plugged and engine at 2000rpm.

2. Yellow to Blue = 26-30v AC stator and battery disconnected and engine at 2000 rpm.

3. Ammeter between red wire and battery positive = 1.5-2 amp with fully charged battery and engine at 2000 rpm

NOTES.

Engine must be earthed to the chassis / battery. Lack of this connection will affect the AC circuit and starter motor but not the DC circuit or ignition circuit.

PUREJET 50 IGNITION / CHARGE

Piaggio Ltd.

02/09/2003

GILERA RUNNER

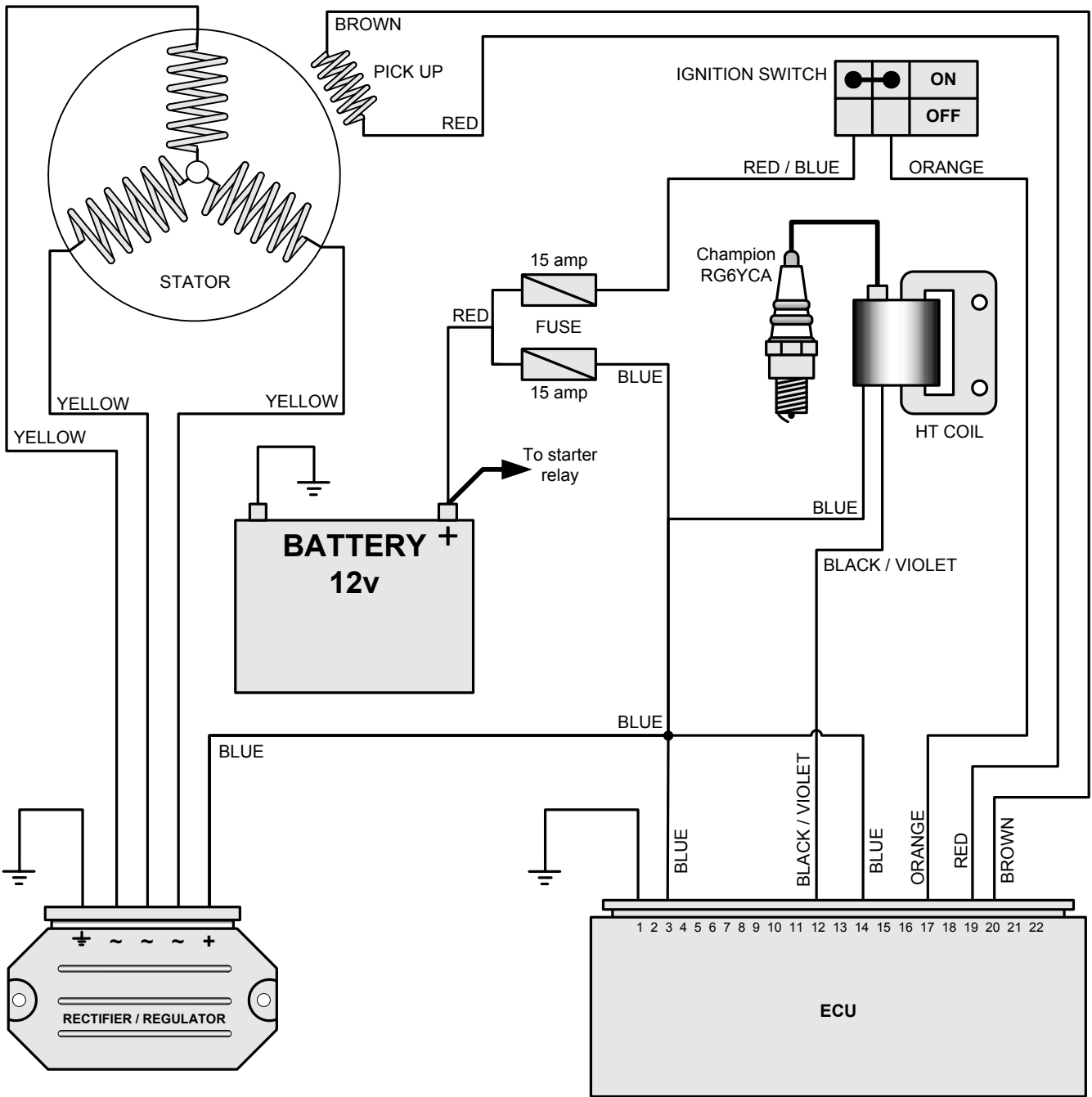

SYSTEM NOTES.

* 3 Phase AC.

* Permanent live battery feed to Rectifier, ECU, HT Coil (blue wire). Any of these could drain the battery if they were faulty.

* HT Coil is triggered by the BLACK / VIOLET wire being earthed via the ECU.

TESTS:

Stator: Disconnected. Any yellow to any yellow = 0.7 - 0.9 ohm. Any yellow to earth = No continuity
Pick Up coil value is not quoted.

Rectifier / Regulator: With a charged battery the possible voltage must not exceed 15.2 volts.

ZIP 125 Leader engine ignition / charging

Piaggio Ltd.

13/08/2003

NO Immobiliser

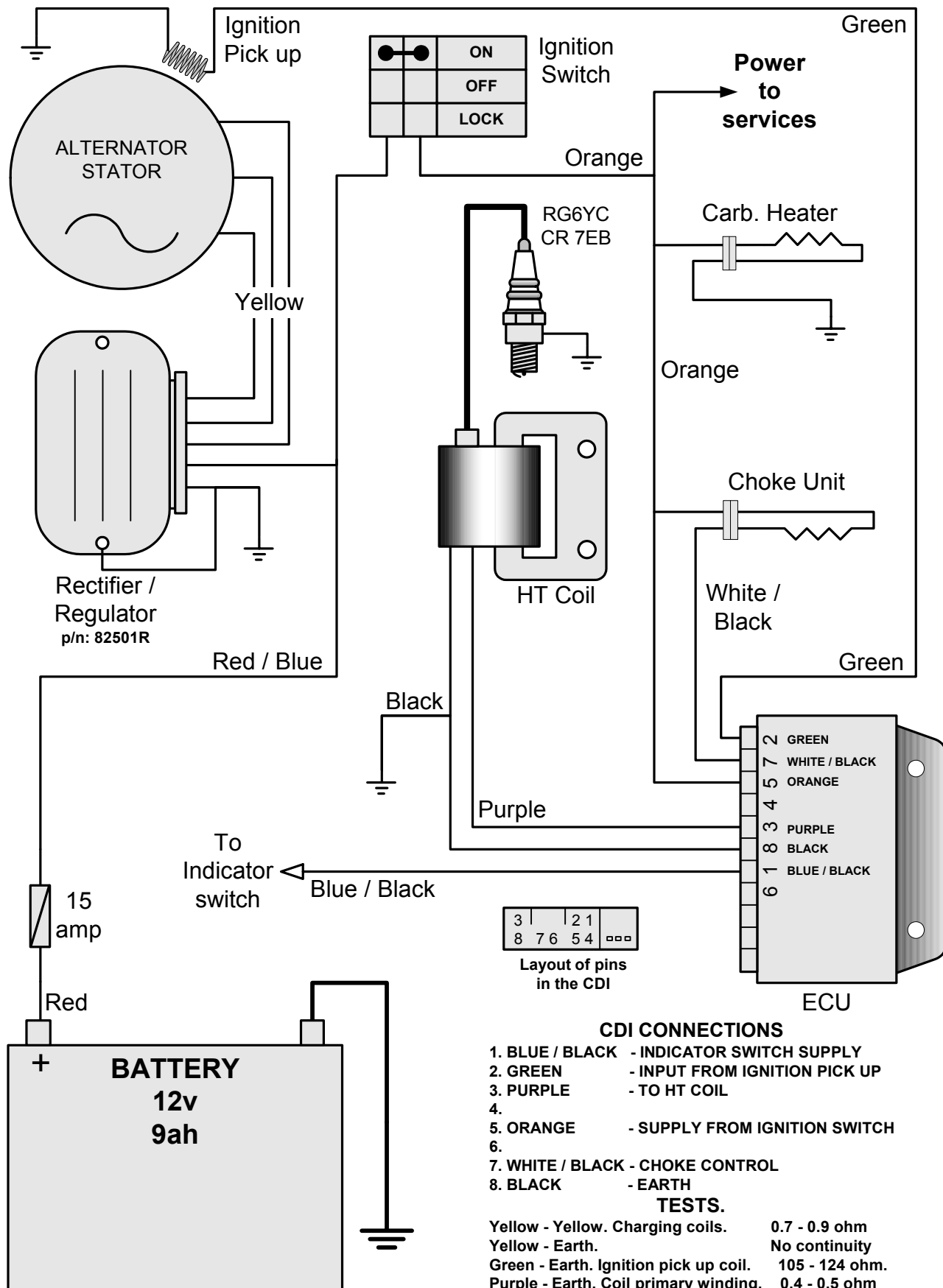

Runner VX / VXR ignition / charging

Piaggio Ltd.

19/07/02

With IMMOBILISER

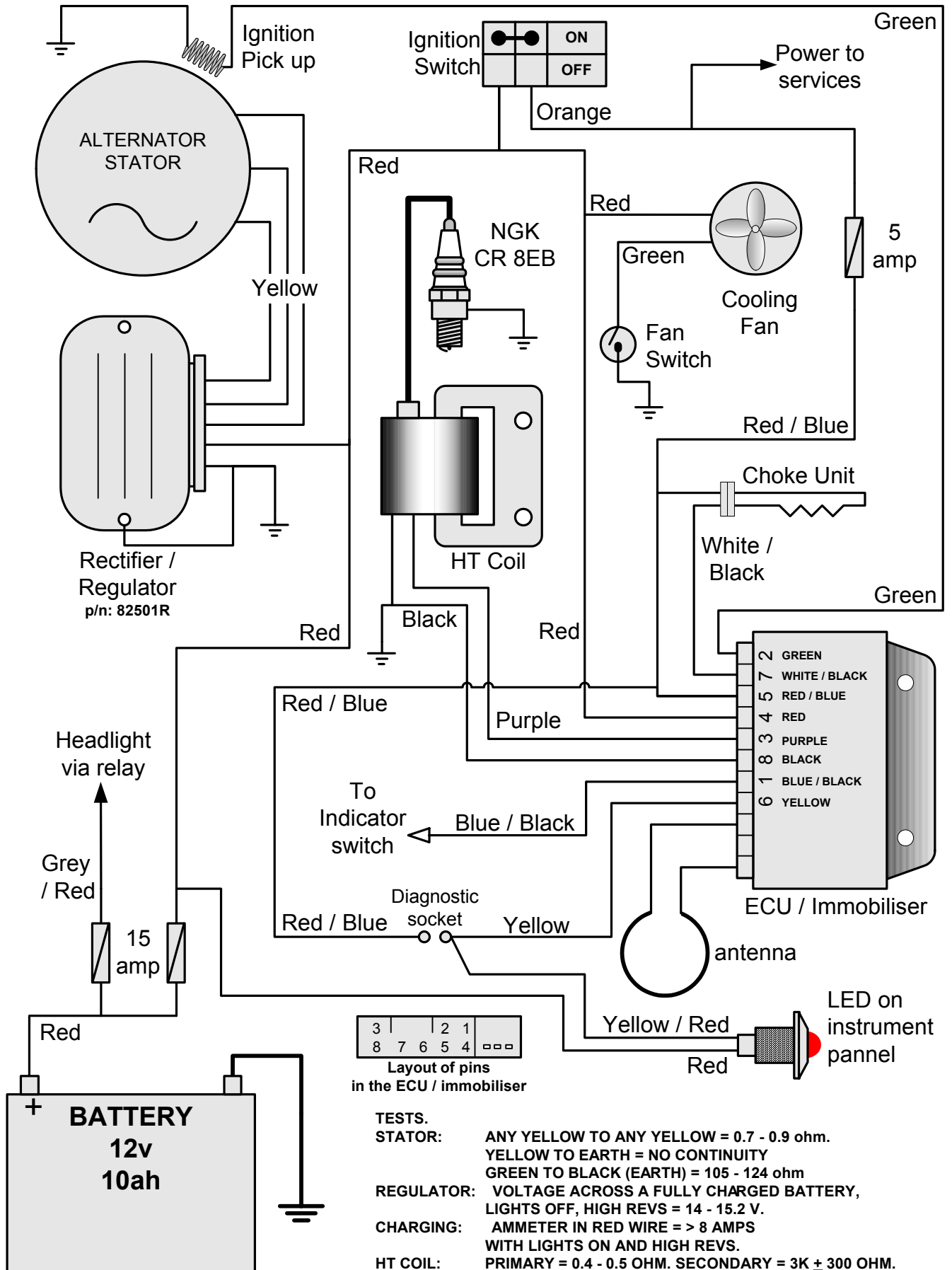

Hexagon GTX 125 ignition / charging

Piaggio Ltd.

13/03/02

With IMMOBILISER

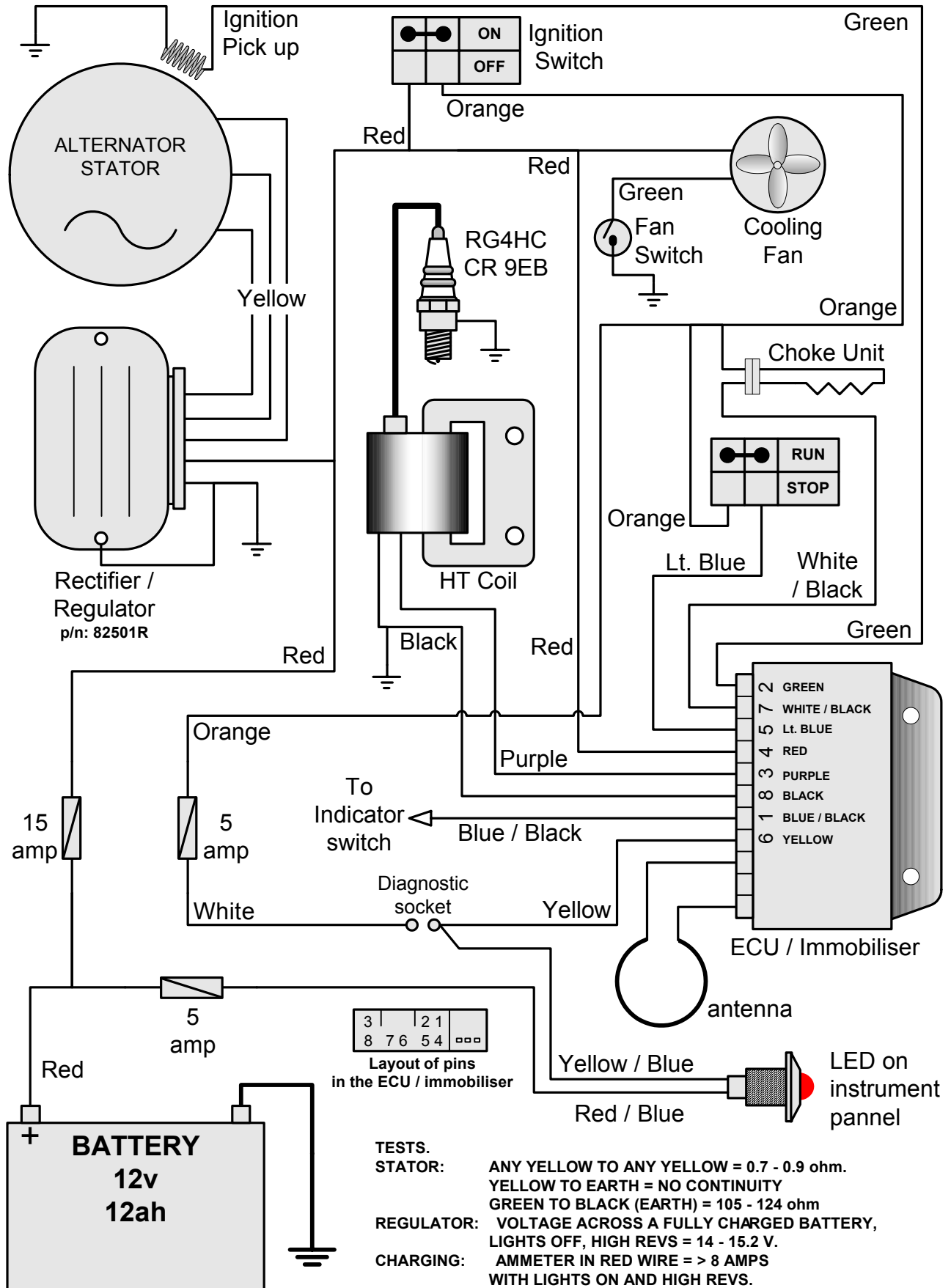

ET4 Leader engine ignition / charging

Piaggio Ltd.

13/03/02

With IMMOBILISER

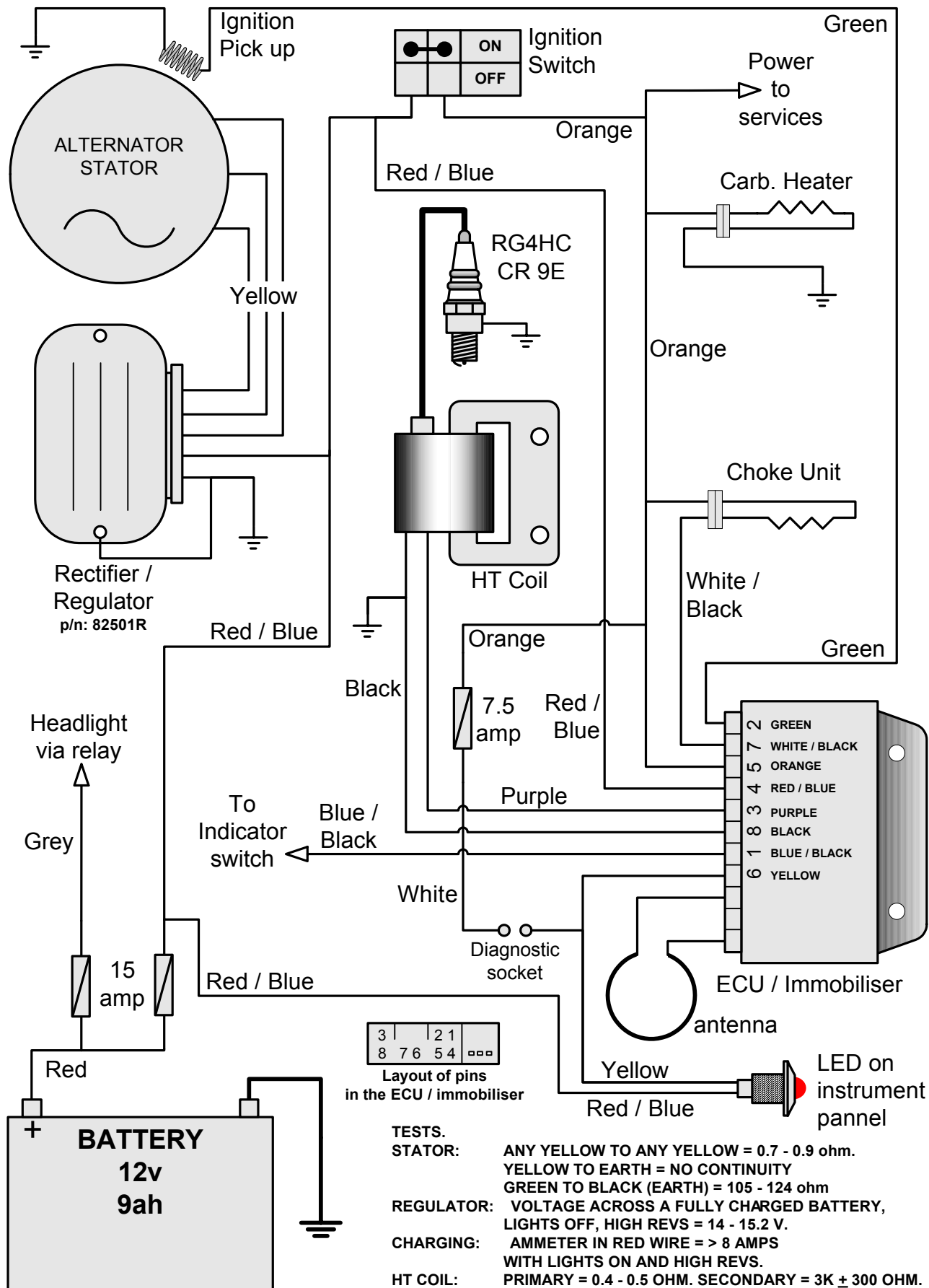

DNA 125 / 180 Switch Wiring

Piaggio Ltd.

08/05/2003

Refer to Service Station Manual
594329 (02/01) page 4-23>

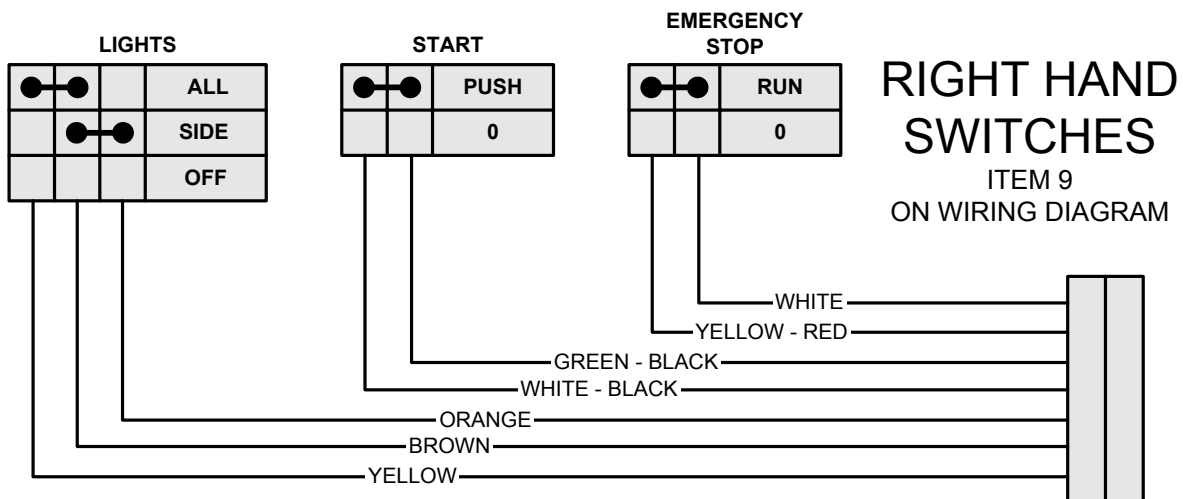
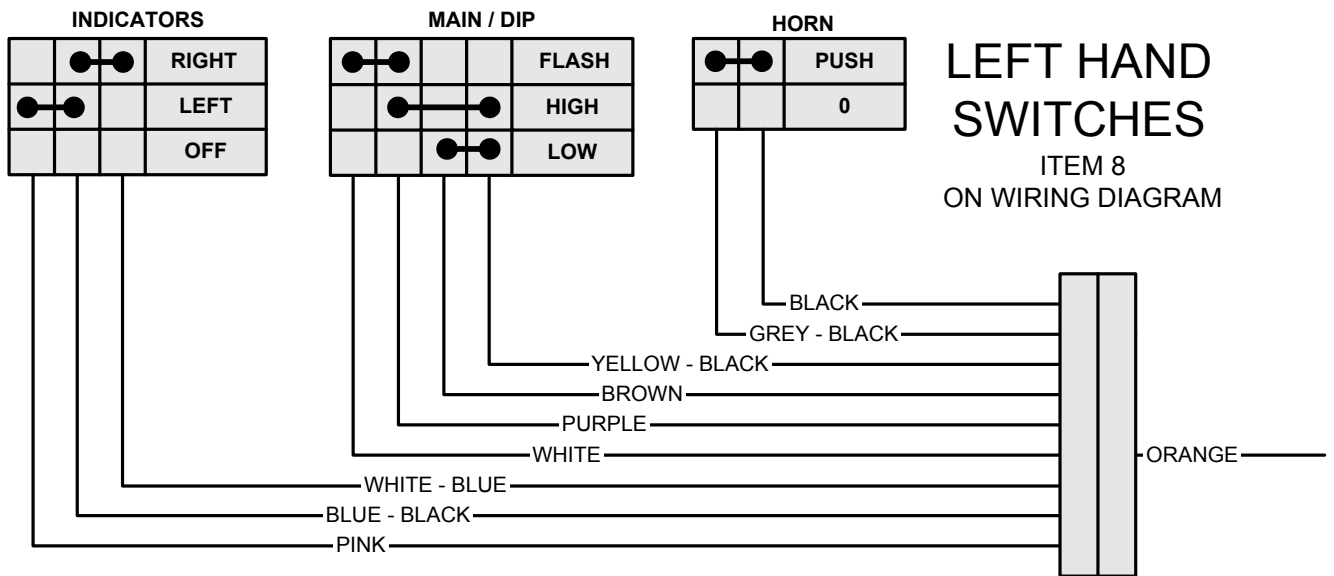
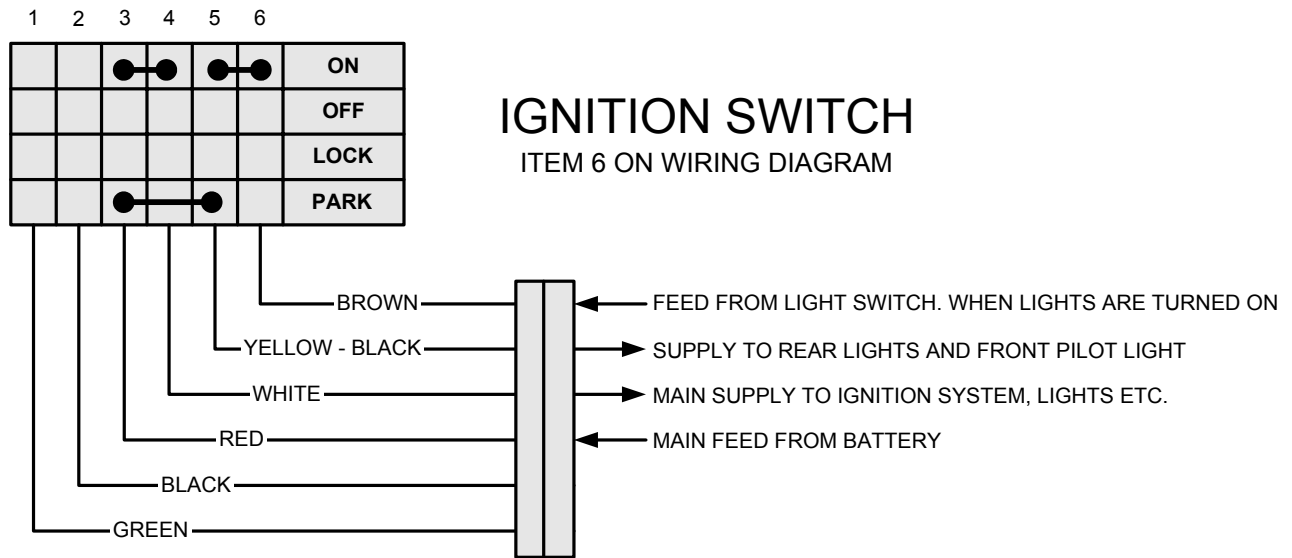

DNA Leader engine ignition / charging

Piaggio Ltd.

13/08/2003

DNA 125 / 180

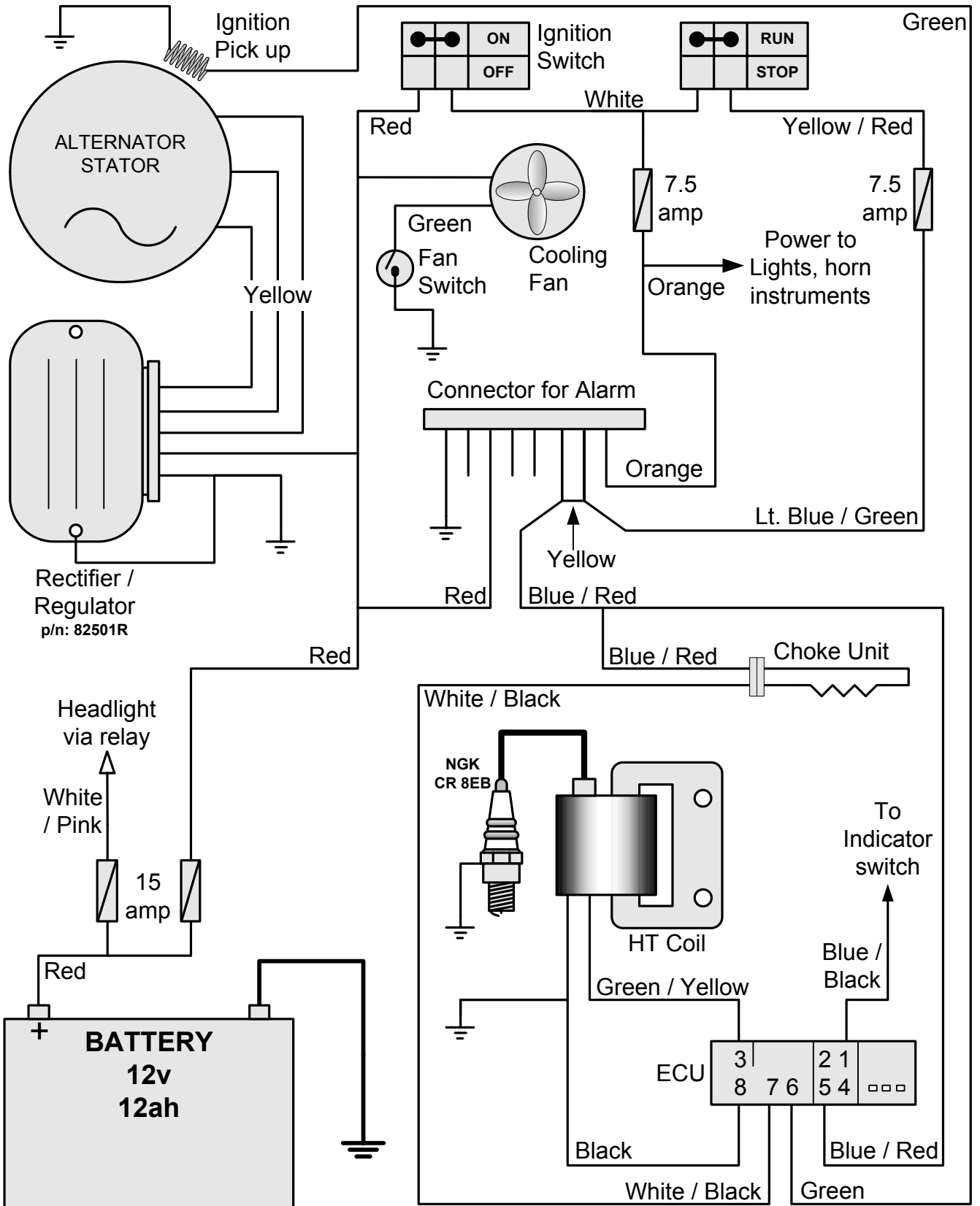

STATOR: ANY YELLOW TO ANY YELLOW = 0.7 - 0.9 ohm. YELLOW TO EARTH = NO CONTINUITY
 GREEN TO BLACK (EARTH) = 105 - 124 ohm
REGULATOR: VOLTAGE ACROSS A FULLY CHARGED BATTERY, LIGHTS OFF, HIGH REVS = 14 - 15.2 V.
CHARGING: AMMETER IN RED WIRE = > 8 AMPS WITH LIGHTS ON AND HIGH REVS.
HT COIL: PRIMARY = 0.4 - 0.5 OHM. SECONDARY = 3K ± 300 OHM.

B 125 FUSE EXPLANATION

Piaggio Ltd.

08/05/2003

Piaggio Ltd.

FRONT FUSE BOX

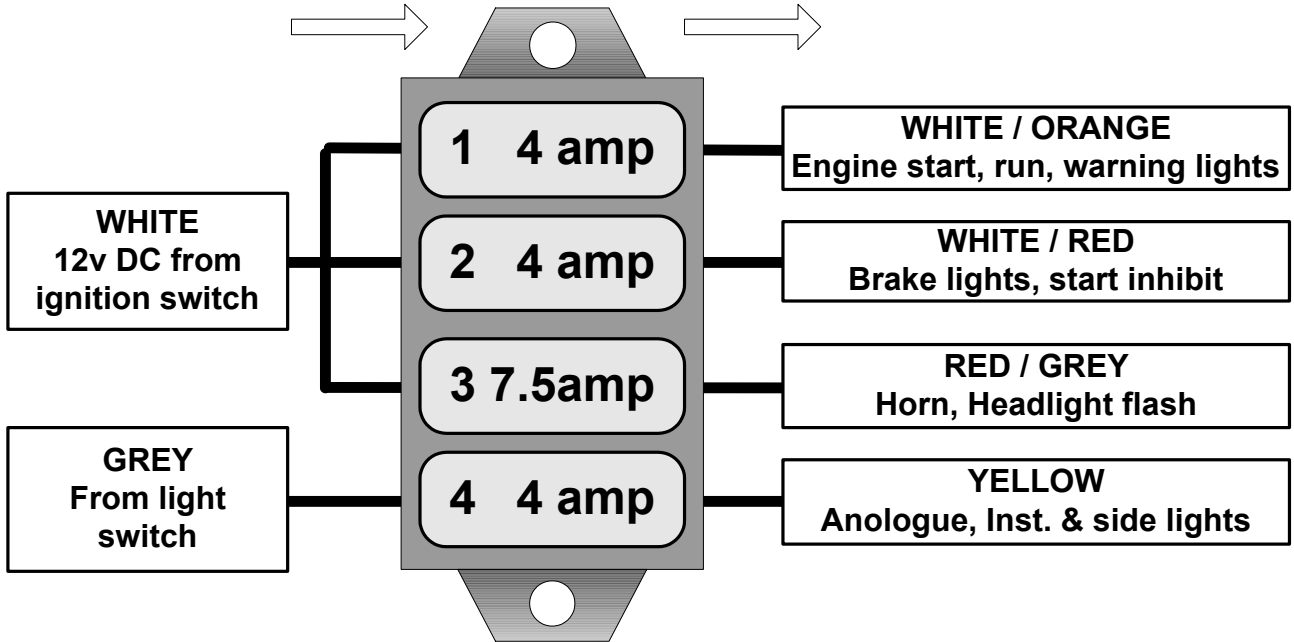

REAR FUSE BOX

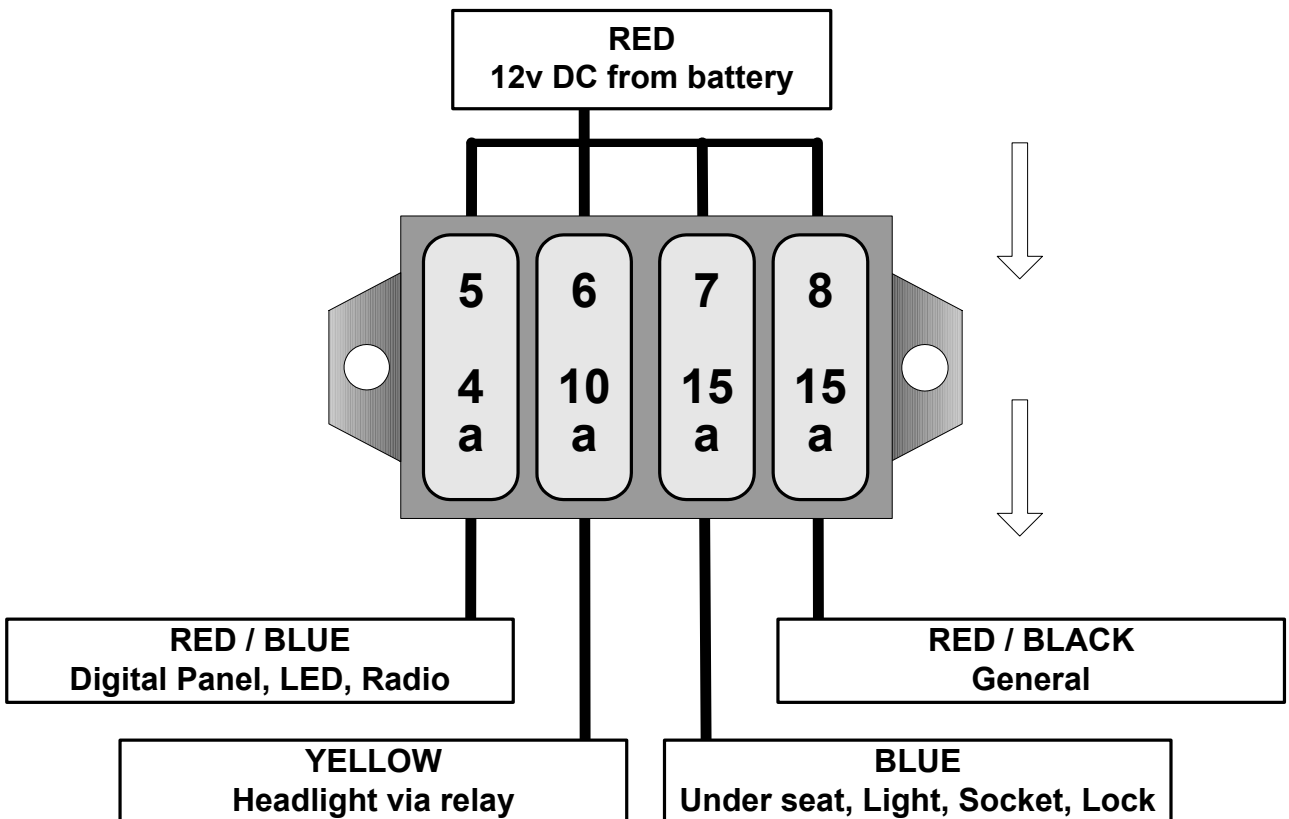

B 125 / 200 NOTES

The notes should be used in conjunction with Service Station Manual 594845 and the notes "B 125 ignition / charging" and "B 125 Fuse Explanation"

1. **Seat has electric release.** Only works when ignition switch is in the "off" position.
If seat lock fails to operate:
 - ❑ Check fuse "7" in rear fuse box. 4 amp red wire in & blue wire out.
 - ❑ Check for power on Blue wire at ignition switch
 - ❑ Check for power on White / Blue wire at ignition switch with ignition "off".
 - ❑ Check the push button, Blue / Black should earth when button is pressed. Seat lock, power socket and under seat light are all controlled by the same fuse.

2. **Wires from The engine.**
 - ❑ Three Yellow wires: Three phases of generator, all feed directly to the rectifier / regulator.
 - ❑ Green wire: Ignition pick up. Goes to CDI unit.
 - ❑ Brown wire: From oil pressure switch, goes to indicator light on instrument panel.

3. **Immobiliser** is like other Leader engines. There are separate notes to explain the immobiliser system.

4. **Fuel system.** (similar to the DNA 125 / 180 four strokes)
 - ❑ Fuel is pumped from the tank and supplied to the carburettor under pressure.
 - ❑ Fuel pump is on the bottom of the tank and is driven by manifold vacuum.
 - ❑ The feed pipe from pump to carburettor has a non-return valve and an inline filter.
 - ❑ 200cc engine may (early vehicles) have a vacuum pipe that branches off to operate an over run valve in the carburettor.
 - ❑ Carburettor icing is controlled by a warm water feed from the cooling system.
 - ❑ Choke is the automatic (wax pellet) type used on all our automatics. Remember that these units default to being "ON" and are turned off electrically. They are more likely to cause running rich when hot than cold starting problems.

5. **Spark Plugs.**
Please note that the correct spark plugs are:
125cc :- NGK CR8 EB p.n. 828866
200cc :- Champion RG6 YC p.n. 828708 (or NGK CR7EB)

B 125 / 200 ignition / charging

Piaggio Ltd.

13/08/2003

With IMMOBILISER

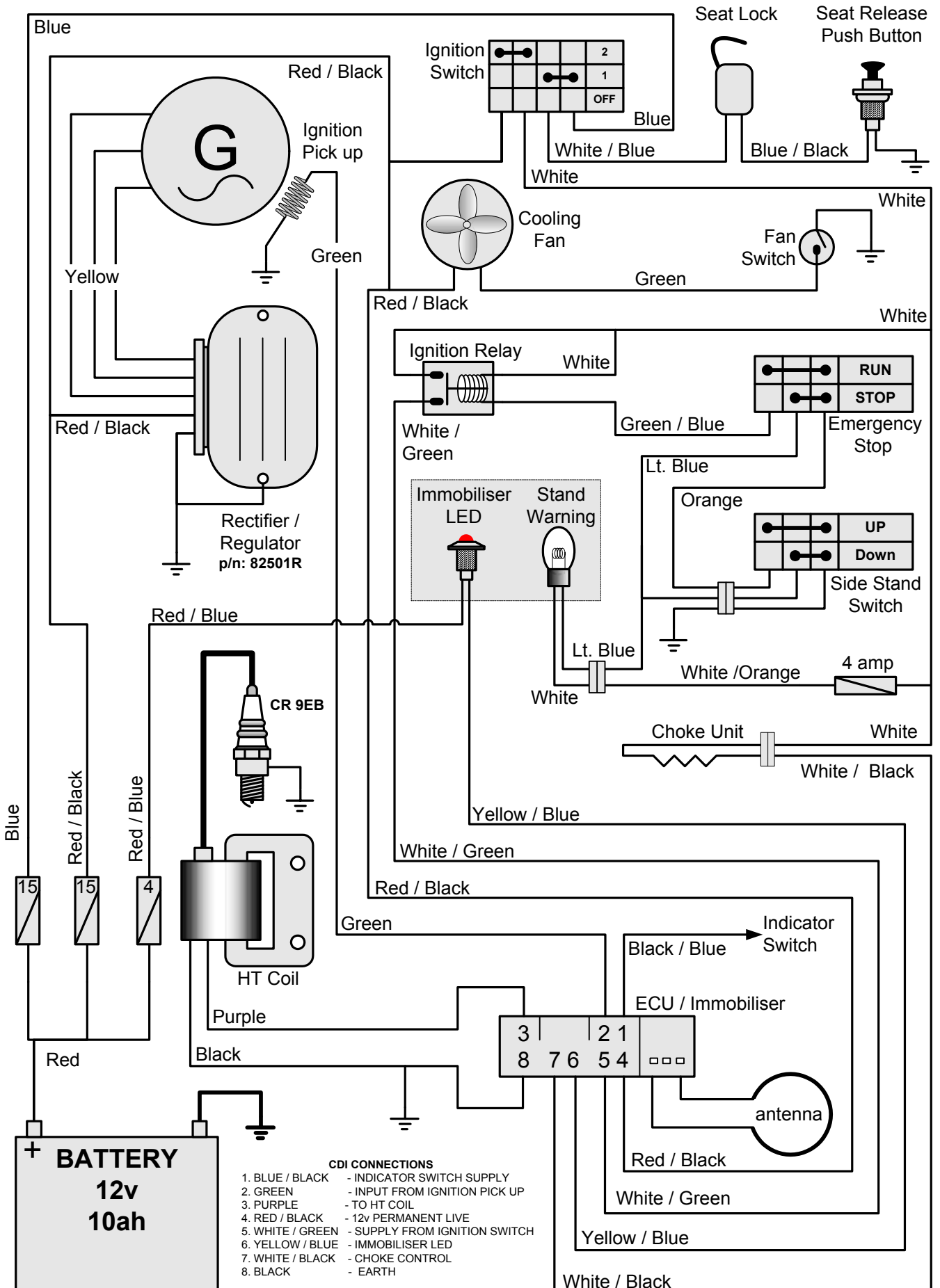

Vespa GT Fuses

Piaggio Ltd.

19/08/2003

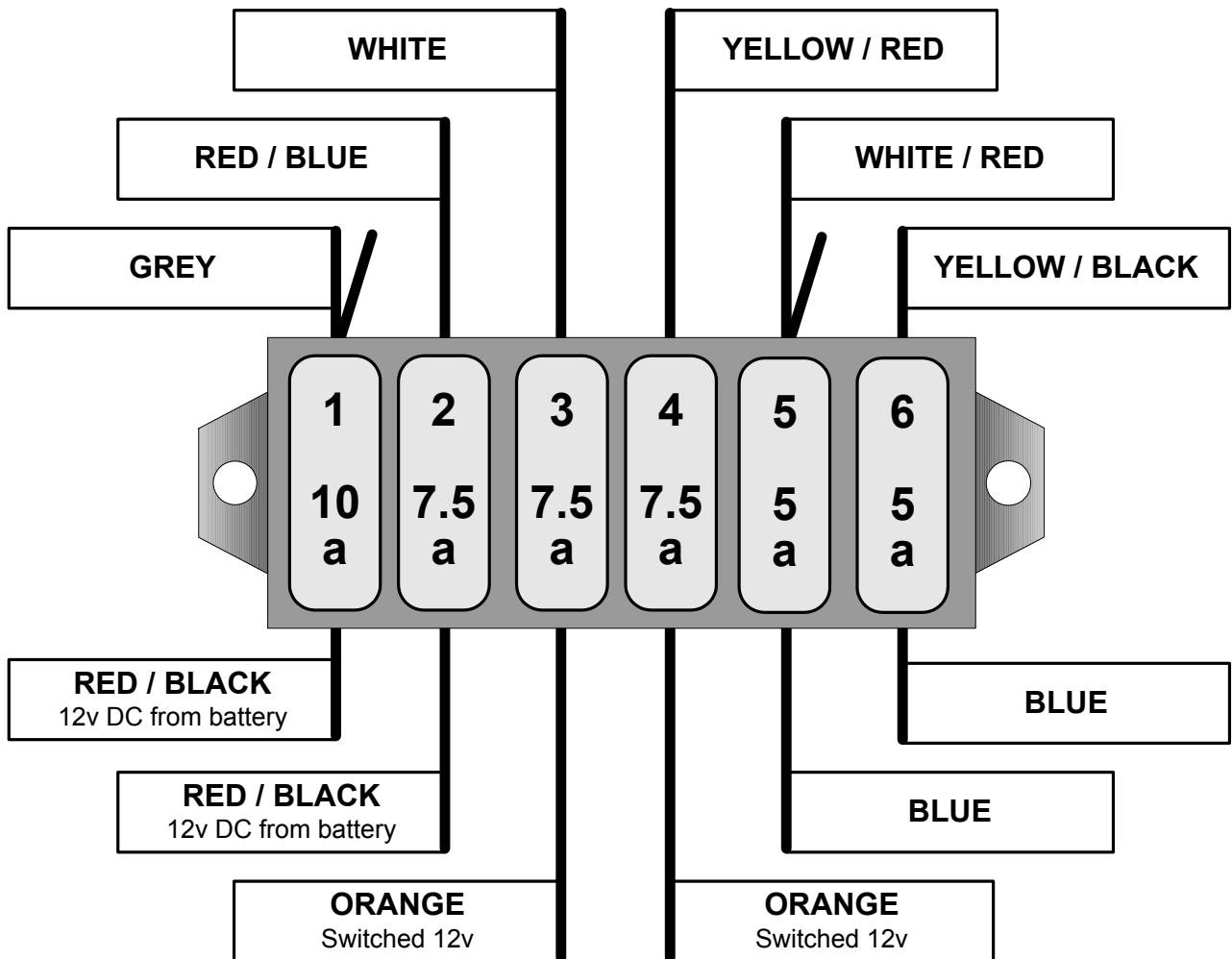

The wire colours shown here are different to those "on line" and in the owners hand book.

The colours and fuse functions here are correct, they were checked on GT200 ZAPM312 * 2550.

FUSE:

1. 10 amp. Electric seat release. Headlights. Main beam warning light.
2. 7.5 amp. Intercom. Alarm. Immobiliser LED.
3. 7.5 amp. Intercom. Alarm. Water temp. Fuel warning & guage. Oil pressure warning.
4. 7.5 amp. Horn.
5. 5 amp. Stop light. start switch.
6. 5 amp. Side lights. Number plate light. Instrument panel lights.

MAIN FUSE.

A 15 amp fuse is located at the front of the under seat compartment.

Vespa GT 125 / 200 ignition / charging

Piaggio Ltd.

18/08/2003

With IMMOBILISER

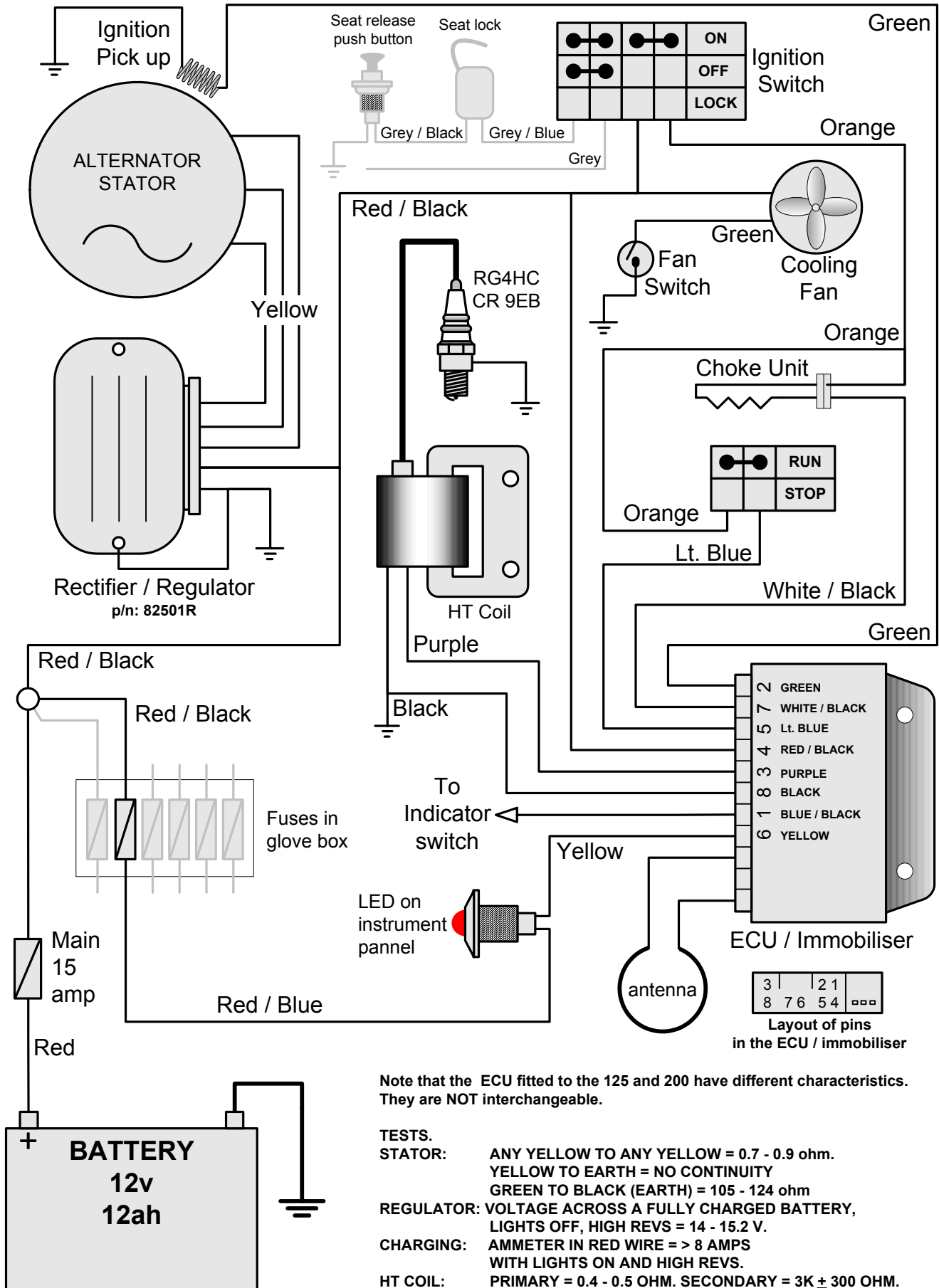

Note that the ECU fitted to the 125 and 200 have different characteristics. They are NOT interchangeable.

TESTS.

STATOR: ANY YELLOW TO ANY YELLOW = 0.7 - 0.9 ohm.
YELLOW TO EARTH = NO CONTINUITY
GREEN TO BLACK (EARTH) = 105 - 124 ohm

REGULATOR: VOLTAGE ACROSS A FULLY CHARGED BATTERY, LIGHTS OFF, HIGH REVS = 14 - 15.2 V.

CHARGING: AMMETER IN RED WIRE = > 8 AMPS WITH LIGHTS ON AND HIGH REVS.

HT COIL: PRIMARY = 0.4 - 0.5 OHM. SECONDARY = 3K ± 300 OHM.

LEADER Engine

Ignition immobiliser

For a full explanation of the immobiliser system please refer to the Service Station Manual. The system is very similar to that used on the original Vespa ET4 but there are subtle differences in operation, fault finding and component replacement. The CDI and immobiliser are now combined in one box.

The vehicle is supplied with two keys. One MASTER key and one SERVICE key. Additional service keys are obtainable but it is not possible to duplicate the master key.

TESTING.

- ❑ Normally **do not** use the master key for testing.
- ❑ Testing is done by using the instrument panel mounted LED.
- ❑ If the system is working normally the LED will be flashing steadily when the ignition is off and it will stop flashing when the ignition is on.
- ❑ If the vehicle has not been used for 48 hours the light will stop flashing to save the battery. It is restored by turning the ignition on and off.
- ❑ If the immobiliser system is faulty, when the ignition is switched on there will be a series of flashes. The flashes hold a key to the fault.

Turn on ignition;

1. The first flash will be long (2 seconds) or short (0.7 second). A Long flash means the system is not programmed. A Short flash indicates that the system is programmed.
2. 2 second pause.
3. Next is a series of short (0.5 second) flashes. These define a fault.
 - 1 flash = System is not programmed. Engine can run but only up to 2000 rpm.
 - 2 flash = No key transponder detected. Fault with Key or antenna.
 - 3 flash = Key transponder detected but not recognised. See the notes below.
4. The last thing to notice is whether the LED finally remains on or off.
 - OFF = Ignition is possible.
 - ON = Ignition is not possible.

Notes.

- ❑ If the system is not programmed the LED indicator may not be flashing with ignition off but it will perform the test function when the ignition is turned on.
- ❑ Wrong key. There are a limited number of mechanical codes used for the keys. It is possible that you could have two vehicles in stock that both have keys with the same mechanical code. If you put the wrong key in the wrong vehicle it will turn on the ignition but you will get the “transponder not recognised” fault code and the vehicle will not start.

Examples.

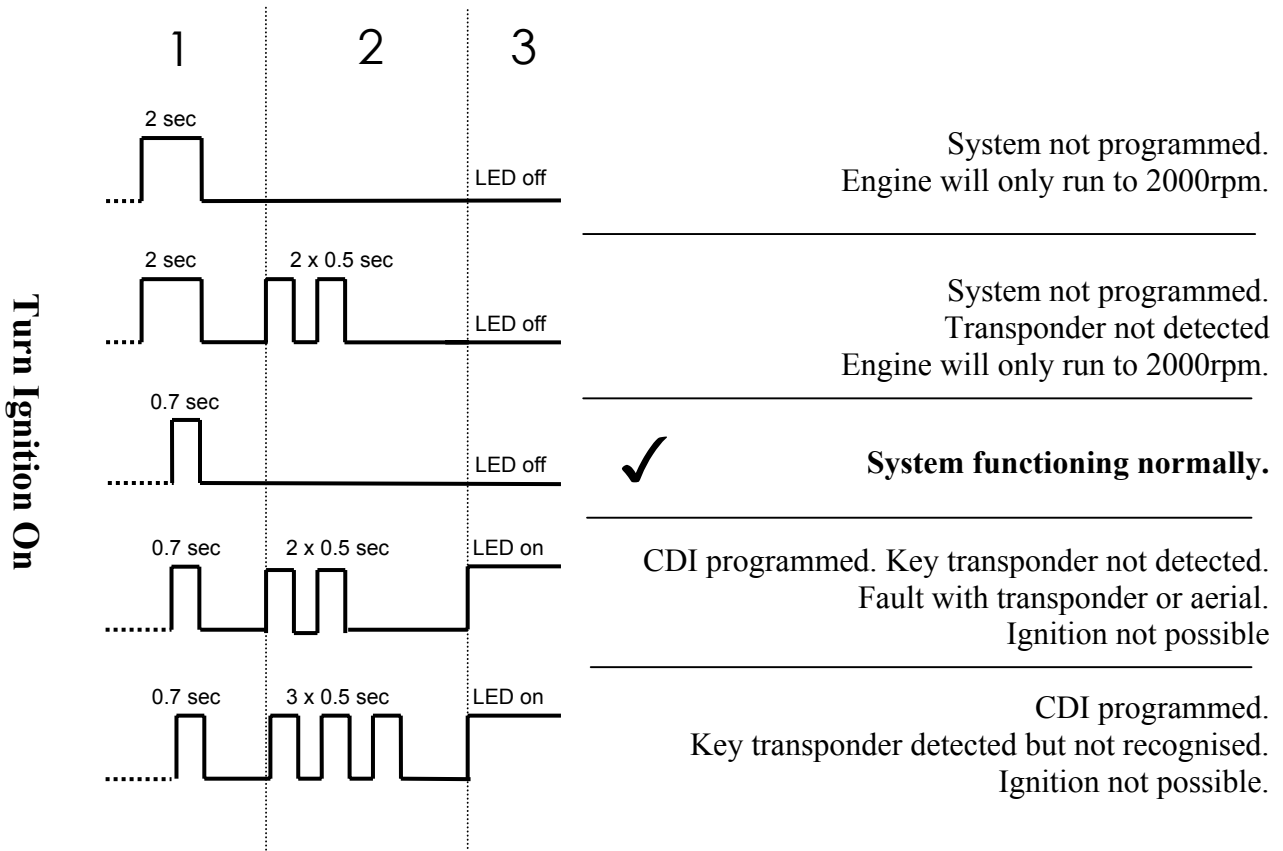

KEYS

The machine is supplied with two keys. One large brown MASTER key (with a flip out section containing the chip) and One smaller SERVICE key.

The MASTER key should be kept safely at home. Only use it for programming.

The service key is the key that is used.

If you require a new service key this can be ordered from Fowlers and then programmed as follows:

Programming New Keys.

It's an easy process but timing is very important.

If the vehicle has a side stand it must be UP and the engine kill switch must be set to "RUN"

1. Master key in and turn on for two seconds, turn off and remove
2. Service key in and turn on for two seconds, turn off and remove (If you have other service keys repeat this with each one).
3. Master key in and turn on for two seconds, turn off and remove

A quicker easier alternative is to obtain a key from any automotive locksmith. The same system is common on cars, most locksmiths will have the blanks and the equipment to identify the chip in your key.

They will cut a key and then fit the correct type of chip into it. This chip will have been "cloned" from your original so you will not need to programme this new key.

If both keys are lost the only solution is to replace the CDI unit and the locks. A new lock set comes with a Master and a Service key.

LEADER ENGINE

Ignition, charging & immobiliser

Use these notes in conjunction with the SERVICE STATION MANUAL

The electrical system on the new Leader engine is very different to previous two stroke and four stroke Piaggio engines. The ignition, charging & immobiliser circuits do not function in the same way and do not share common components with previous versions.

- ❑ Ignition is now using the battery circuit. Everything shares one common supply.
- ❑ Alternator has three phase (all yellow wires) and ignition pick up coil (green wire) outputs only.
- ❑ Rectifier / Regulator is very simple. Three phase (yellow) inputs and one output.
- ❑ CDI unit has become more complicated. The one unit is responsible for: ignition, immobiliser, indicators & choke unit.
- ❑ Much of the circuit is the same on ET4 Leader, Super Hexagon GTX 125, Liberty 125 Leader, Skipper ST, Runner VX / VXR and DNA 125 / 180, X9 125 but be careful because there are differences. Early Skipper ST did not have an immobiliser, they do have it now.

IGNITION.

When the ignition is turned on power is supplied to the CDI (terminal 5).

Ignition pick up is via green wire (terminal 2).

Output to the HT coil is via purple wire (terminal 3).

The unit is earthed via black wire (terminal 8).

CDI / IMMOBILISER

Note the CDI units have different part numbers for different models and engines size.

Refer to the diagram for each specific model. The wiring and wire colours may vary.

It is important that the correct part number is used as the ignition characteristics vary and although the units look the same they are different!

On vehicles with an immobiliser;

The wires connected to the unmarked terminals are from the antenna that is mounted around the ignition lock barrel.

Check antenna for continuity, unplugged resistance = 7 - 9 Ω .

The red or red / blue wire (terminal 4) supplies battery voltage even with ignition off.

Yellow wire (terminal 6) is from the LED on the instrument panel. If the system is programmed and working correctly the LED should be flashing steadily with the ignition turned off to confirm that the immobiliser system is functioning. The immobiliser earths the LED (or not) to make it turn on or off.

See pages 3-4 below for more details on using the LED for immobiliser fault finding.

HT COIL. 82597R = Common to most Leader engines. 82582R = Skipper ST & X9 125

- ❑ Purple to Black - primary winding = 0.4 - 0.5 Ω
- ❑ HT to Black - secondary winding = 3000 \pm 300 Ω
- ❑ Plugged in with engine cranking the peak voltage Purple to Earth = 100 vdc

IGNITION PICK UP COIL.

- Un plug, check resistance, Green to Black = 105 - 124 Ω
- Un-plugged with engine cranking the peak voltage Green to Black = 2 vdc

STATOR.

Any yellow to yellow should give continuity. Un-plugged, yellow to yellow = 0.7 - 0.9 Ω
Yellow to earth should not give continuity.

RECTIFIER / REGULATOR. p/n 82501R common to leader engines.

- Regulated voltage. With a fully charged battery check charging rate by putting volt meter across the battery terminals. Peak voltage = 14 - 15.2 vdc. Engine at high speed and lights off.
- Charge current. Connect ammeter to the red wire. Then Start engine. Charge \geq 10 amp. With the head light turned on.

INDICATORS.

There is no separate indicator relay. The relay function is contained within the CDI unit, Power to the indicator switch is via the blue / black wire (terminal 1).
If the indicators fail first check that you are getting voltage at terminal 1 (blue/black)
To check the switch and wiring. Unplug the CDI and link red/blue wire to blue/black wire, when the turn switch is operated the appropriate lights should come on. (you will not need the ignition to be turned on).

CHOKE UNIT.

The choke is now controlled by the CDI. (not the regulator).
Power is supplied to the choke via the main switched wire from the ignition switch to the CDI. The unit will not function until the engine is running when the CDI will complete the circuit to earth (terminal 7).

- Un Plugged, resistance across the connections = $>> 30 \Omega @ 20^{\circ}\text{C}$
- Plunger extension. Measure how far the plunger protrudes from the body when it is cold, this should be 12.5 - 13.0 mm. Now connect the choke unit to a 12v battery. The plunger should have extended to 18.5 - 19.0 mm within 5 minutes.
- Supply. Orange or Red / Blue to earth = Battery volts with ignition on.
- Orange or Red / Blue to White/Black = 13-14.5v dc (system volts) with engine running.

CARB. HEATER. Fitted to air-cooled engines.

The carb heater will start working as soon as the ignition is turned on. Power is supplied via the switched wire that goes to the CDI.

Water cooled engines use a warm water connection from the cooling system.

COOLING FAN. On water cooled engines.

The live feed from battery to fan is permanently connected. The switch is in the earth from the fan. So if the fan is faulty it could be the cause of a flat battery.

X9 125 / 180 ignition / charging

Piaggio Ltd.

25/10/02

With IMMOBILISER

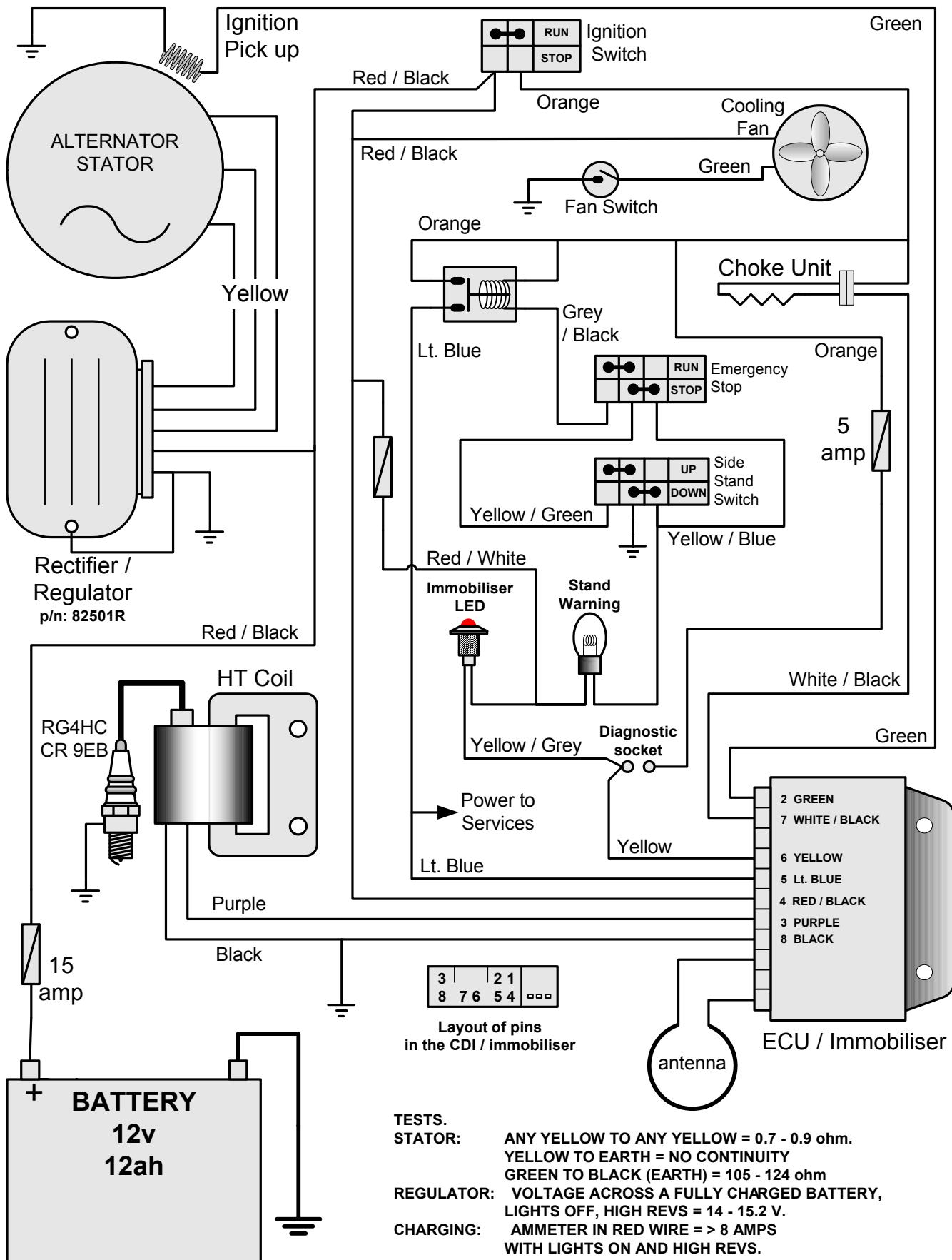

50cc 4 stroke Charging / Ignition

Piaggio Ltd.

22/11/01

Piaggio Ltd.

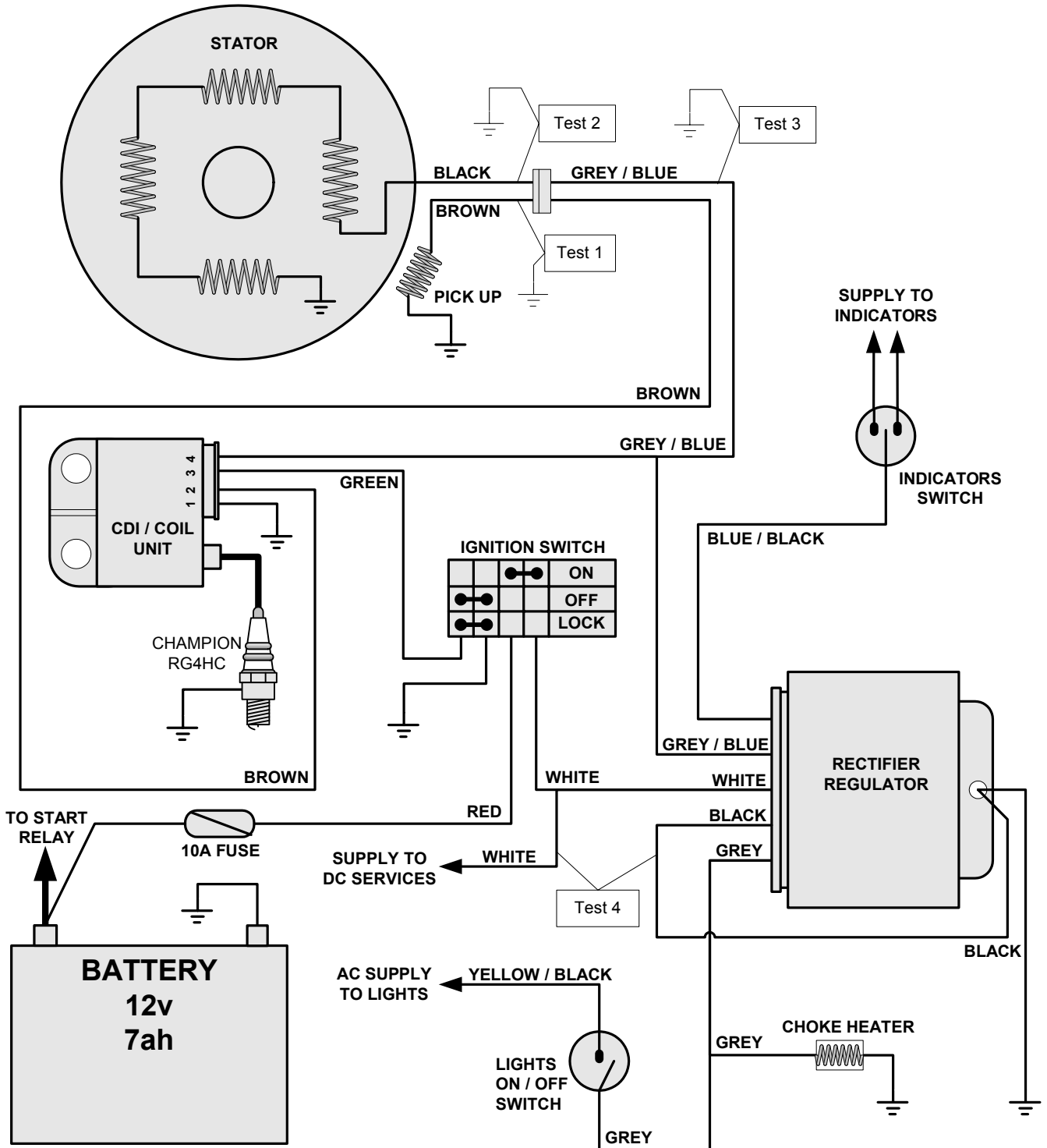

Only two wires come from the stator. The engine to earth connection is very important.
 Battery voltage at idle = 13 v (Battery charged) max will be 14.5 volts at high revs. Meter between battery neg. & pos.
 Battery charge at idle = 1.5 - 2 amps (lights off). max will be >5 amps at high revs with all lights on. Meter between red wire and battery pos.
 Test 1: Brown - earth = ~170 ohm To test pick up coil. Stator un-plugged
 Test 2: Black - earth = ~1 ohm To test charging coils. Stator un-plugged
 Test 3: Blue / Grey - earth = 25 - 35 v ac @ 2000 rpm with regulator disconnected. To test charging coils.
 Test 4: White - Black = ~8 M ohm. If the resistance is low it could cause the fuse to blow.

This information is intended **only** for authorised Piaggio dealers.

50cc Four Stroke Restriction

Please refer to the notes about the legal implications of de-restricting a moped.

Piaggio do not advocate changing the restriction on any 50cc machine that may be used on public roads.

Remember that if a Piaggio, Gilera or Vespa 50cc moped is de-restricted it will almost certainly be technically illegal. It will not conform to Motorcycle legislation but it did conform to Moped legislation.

The main restriction on the 50 cc four stroke engine is electronic. There is no restriction in the exhaust pipe.

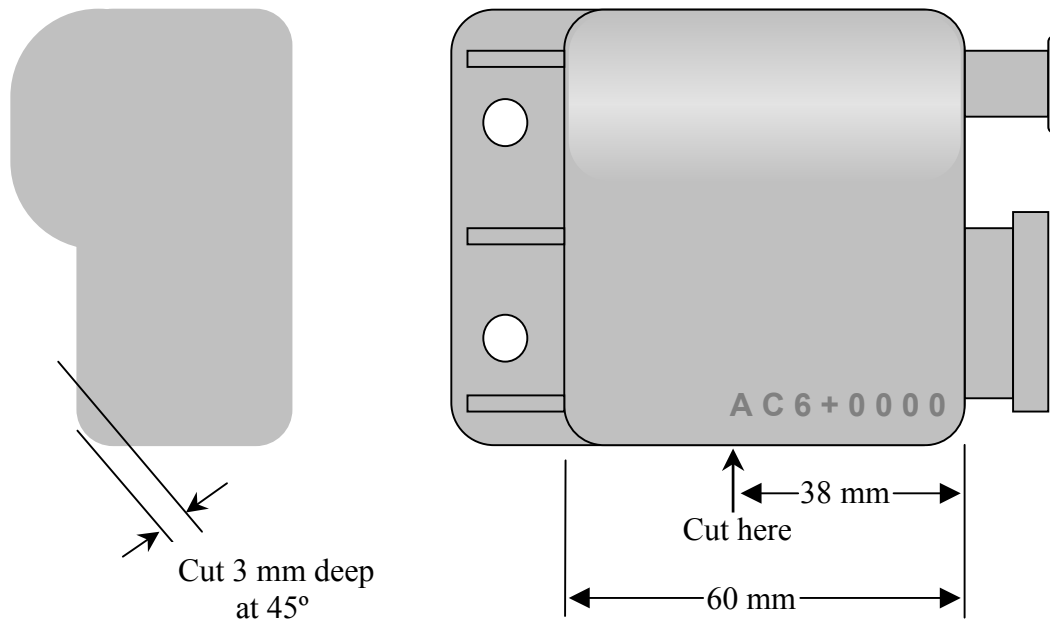

1. Make a 3mm deep cut with a hacksaw in the position shown. Then fill the slot with silicon.
2. Remove the spacer washer between the front pulley halves.
3. Fit carburettor main jet size #78. Part number 969622

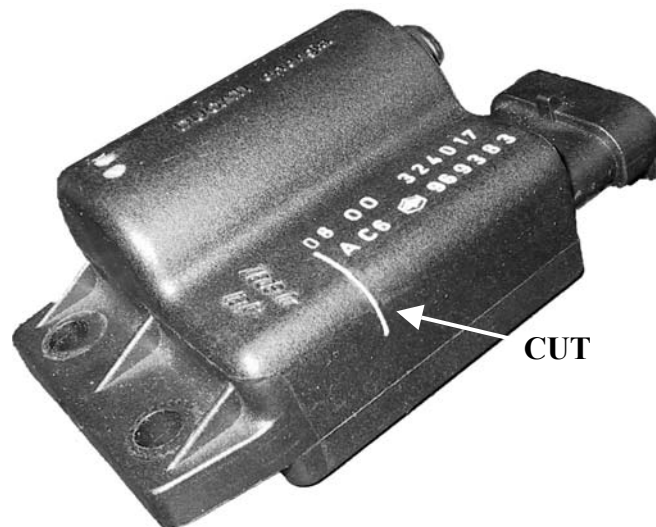

X9 250 (Honda engine)

* At PDI

Set the clock TIME and DATE.
Set the TRIP to MILES.
Reset all three SERVICE LIGHTS.

* To change km to miles.

Insert ignition key.
Press and hold down “Trip” and “M” buttons
Turn on the ignition.
The display should now have changed.

* To reset the service light.

1. Remove the central panel between the headlights, this is retained by 5 screws.
2. You will find a button above the headlight unit marked “RES”
3. Turn on the ignition. One of the three service lights will be flashing.
4. Briefly press the button. The light before the one you want to reset should light.
5. Press and hold the button. The light you want to reset will start flashing fast. While it is flashing fast release the button. Now the light should have gone out.
6. Turn off the ignition and turn back on to prove the light has been cancelled.

* To test System.

With ignition off.
Press and hold down “clock” and “set” buttons
Turn on the ignition
All the systems will check them selves and all the lights should come on.
Any blown bulb or faulty system will be obvious.

* Stop lights.

There are a total of five stop light bulbs.
If two or more bulbs fail the warning light will come on.

* Hazard Lights.

Ignition on
Press hazard button, lights will start flashing.
Turn ignition off.
To stop the lights, first turn the ignition on then press the switch.

* Battery current drain.

Current drain with ignition off should be 1-1.5ma. This equates to a useful battery life of 40 days without any charging.

Test the drain by inserting your meter between battery and earth lead.

* If the battery is going flat check that the helmet compartment light is going out. Remove the battery cover to see into the helmet compartment with seat closed.

* Battery charging.

Charging at idle (1500 rpm) with the main beam on should be 2 amps.

*** Low fuel warning lamp.**

The light will only come on when it has received a continuous signal from the sender for 13 seconds.

*** Relays.**

The vehicle has five relays.

Starter relay p/n 496403 has a 30 amp fuse and is in the battery compartment.

Start Permission relay p/n 292332 is in the battery compartment.

Two head light relays and the main power relay are all the same p/n 58002R they are all under the front shield, headlights are central and the power relay is on the near side by the indicator.

*** Headlights.**

The headlights are controlled by relays and each has it's own relay so if the light fails and it is not the bulb, check the relay.

*** Choke unit.**

Temperature sensor in the radiator can control the choke.

If the temperature drops to 0 degrees C then choke will come on (no voltage to the unit)

*** Honda Foresight Engine.**

There are two versions of the engine. The engine number will contain the letter "X" or "UU" . Piaggio use the "UU" version. Specific parts for this engine are identified by the colour blue (blue rollers etc.)

*** Valve clearance.**

Set Cold.

Engine at TDC.

Valve clearance is one division on the scale.

*** Gear Box Oil Level**

Remove the level screw.

If no oil comes out top up until oil drips then wait until oil stops before re-fitting the bolt.

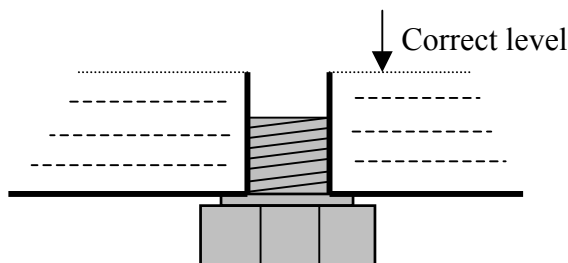

*** Indicators**

The indicator relay function is part of the digital display cluster. P/n. 581413. There is no separate relay.

The wires involved are:

Blue / Black - right turn

Grey / Blue

Red / Black - left turn

Note that to operate the indicators the handlebar switch shorts the relevant wire to earth.

Hazard lights work by the switch earthing the brown wire from the digital cluster.

*** Braking system**

1. Three brake disks are all the same size. 200mm diameter.
2. Both master cylinders are the same size.
3. All brake pads are the same. p.n. 494966
4. L/H front and rear calliper are the same and have 22mm pistons
5. R/H front calliper has 24mm pistons.
6. L/H front and rear are linked together in the following way
When left hand lever is used
Up to 8 bar pressure the rear brake only is operated.
8 - 23 bar both brakes are applied.
Over 23 bar the amount of pressure to the front brakes begins to decrease relative to the rear.
7. The R/H front calliper is operated by the R/H brake lever and has no connection to the other brakes.

*** Rollers and Drive Belt**

Roller kit p.n. 496293. Roller min dia. = 22.5mm. Rollers are coloured blue.
Drive Belt p.n. 496304 Min width = 22.3mm

X9 250 CHARGING & IGNITION

Refer to the X9 Charging & Ignition diagram.

* Note that sometimes the wires coming from a component change colour at the connector that joins them to the wiring loom.

* See the separate sheet for an explanation of the fuses.

* Charging is three phase, fully rectified.

* Ignition is digitally mapped and can not be manually adjusted.

Spark advance will be affected by:

- Engine speed.
- Throttle position. See # 1
- Coolant temperature. See # 3

1. **Throttle position sensor** is on the carburettor.

Power supply is nominally 5v dc.

Resistance drops as throttle is opened.

2. **Auto Choke.** Normal wax pellet type. Defaults to “on” it is controlled by the ignition control box and can be turned on by low coolant temperature (temperature sender in radiator). If coolant temp is less than 0°C the choke will stay on.

Checks.

1. Remove the choke unit from the carb. Measure the length of the plunger extension.

Attach the choke to a 12 volt battery, after 4-5 minutes the plunger should have extended by about 4.5 mm.

2. White/Black wire should have 12v when ignition is on.

Yellow /White wire should have continuity to earth when the engine is running.

3. **Radiator temperature sender.**

This is on the right hand side of the radiator. The fan switch is on the left.

4. **HT Coil.**

Primary. White/black to blue/yellow = 3Ω

Secondary. HT to blue/yellow = 15,000Ω (15k)

Plug cap. 5,000Ω (5k)

5. **Fuel Pump** is situated under the left foot board.

6. **Stator.**

Charging coils. yellow to yellow = 0.6Ω

yellow to earth should give continuity.

Ignition Pick up. White/yellow to yellow = 200Ω

7. **Rectifier / Regulator.** With a fully charged battery. To check the charging rate, place a voltmeter across the battery terminals.

With lights off you should have 14-15 volts at 5,000 rpm.

8. **Battery** drain with ignition off should be 1-1.5 ma. This gives a useful battery life without charging (or use) of about 40 days.

#9. **Start Permission Relay.**

Situated in the battery compartment. Contacts are normally closed. When green/black is earthed by the stand switch the contacts will open to break the start circuit..

#10. **Engine Stop Switch.**

The yellow/green wire from the ECU must be earthed to allow the engine to run. When the stop switch is “stop” the connection to earth is broken.

X9 250 Charging & Ignition

Piaggio Ltd.

04/11/2002

Honda Engine

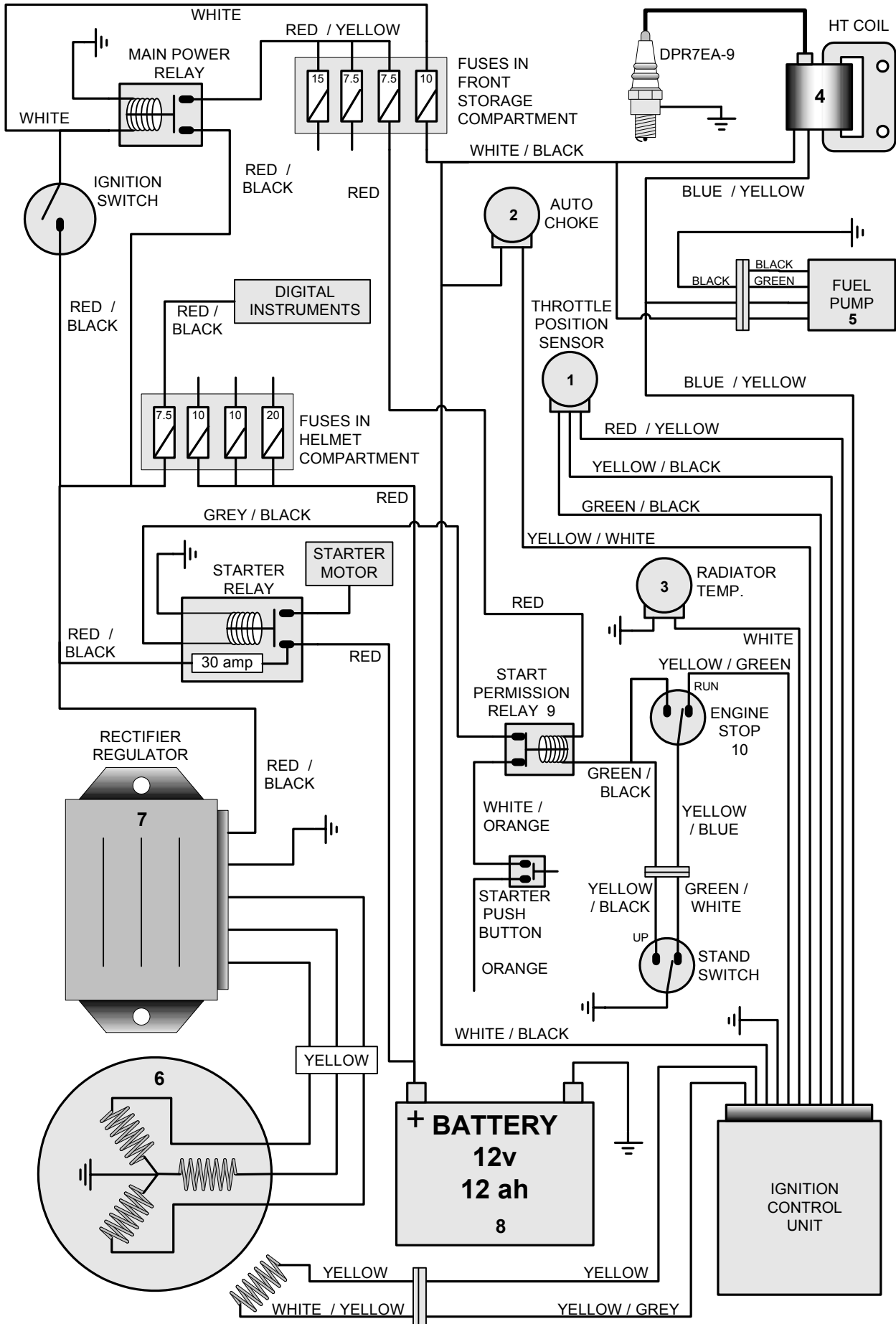

LIBERTY 125 Charging Circuit

RECTIFIER / REGULATOR WITH AN EIGHT PIN CONNECTOR

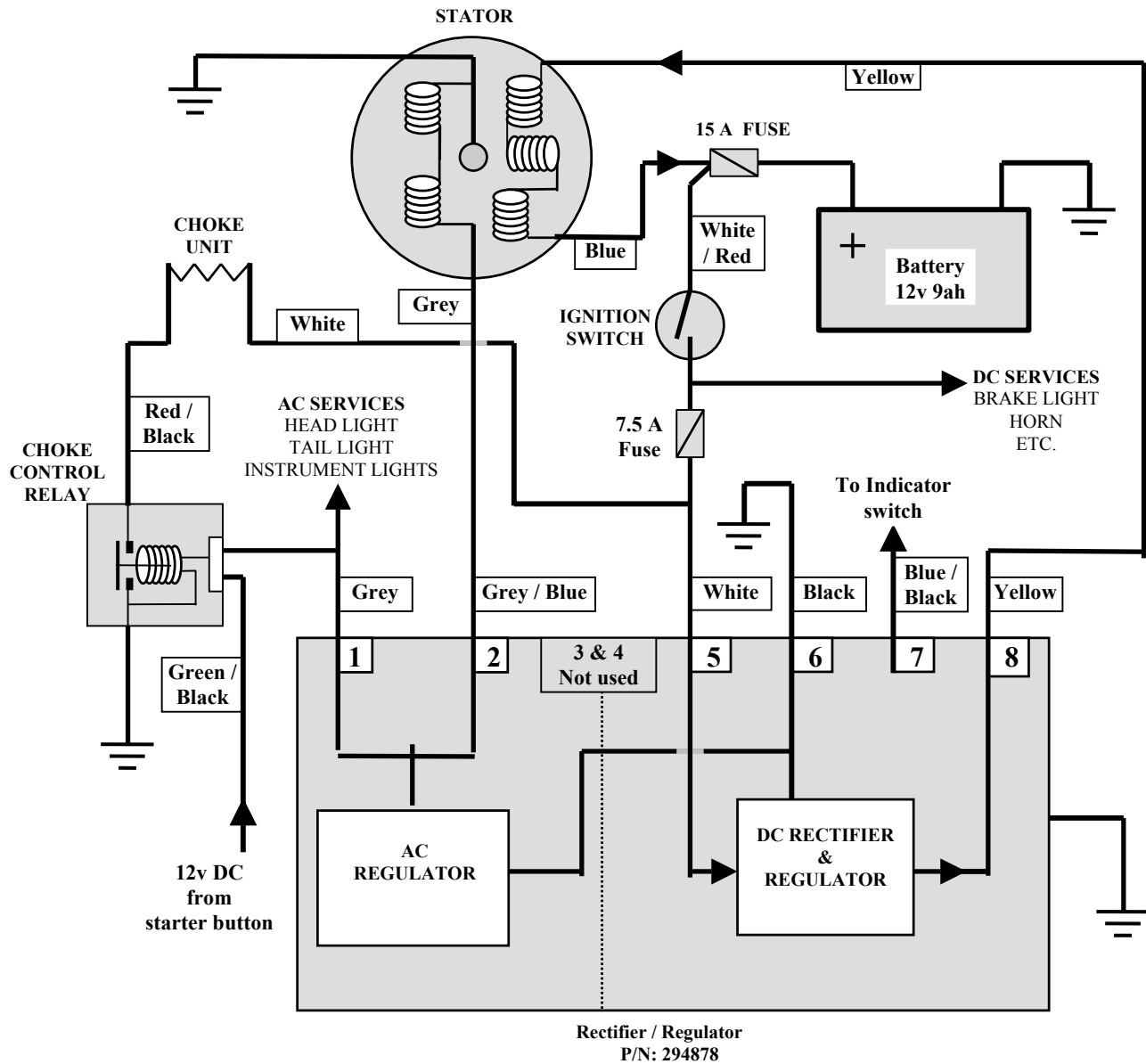

THIS IS THE ORIGINAL ENGINE NOT THE LEADER

- The charging system is basically the same as the 50 / 80cc Sferoids.
 1. Two completely separate circuits, AC & DC.
 2. DC circuit is regulated on the negative side of the alternator.
- The eight pin rectifier / regulator combines the indicator relay.
- Choke unit is supplied with + 12v DC when ignition is switched on. But current can only flow (via choke control relay contacts) when the engine is running so AC is present to pull the relay "in". A logic circuit in the relay will not allow the choke to begin to turn off while the starter button is being pressed.

HEXAGON 250

Charging & Ignition Circuit

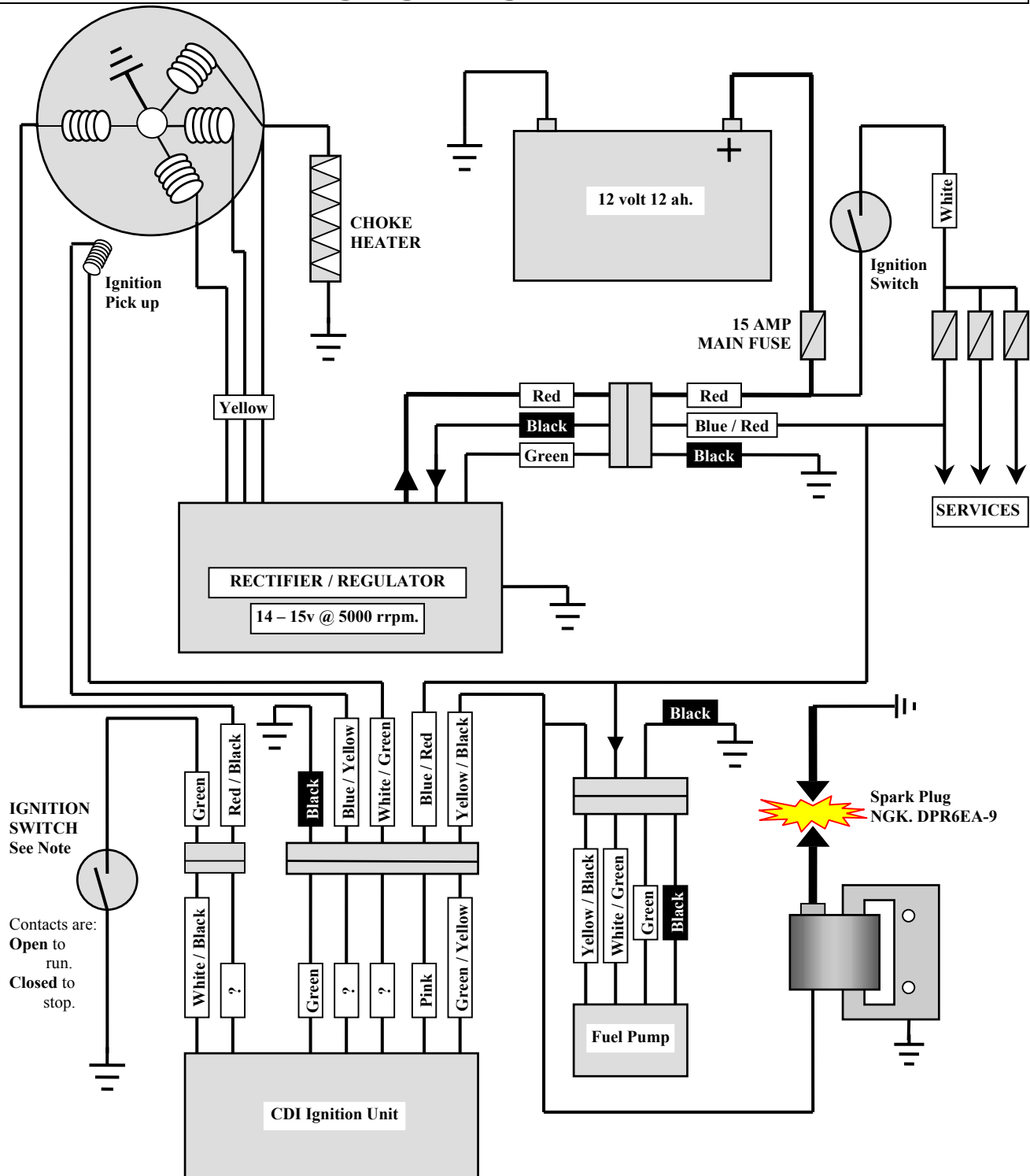

- Note that the wire colour sometimes changes from one side of a connector to the other.
 - The choke supply is $\gg 12$ volts AC (only when the engine is running).
 - The fuel pump senses the engine speed and varies the supply rate accordingly.
- TESTING. **Green – Black:** No continuity with ignition switch and kill switch to Run.
Yellow - Yellow - Yellow: 0.1 – 1.0 Ω . Stator winding.
Black/Red – Black: 50 – 350 Ω . Ignition charging coil.
Green/White – Blue/Yellow: 50 – 170 Ω . Ignition pick up coil
Yellow/Black – Black: 0.1 – 0.2 Ω . HT coil primary winding.
HT – Black: 3.6 – 4.6 K Ω . HT coil secondary winding.

ET4 (original type) IGNITION IMMOBILISER.

General description

The ignition key contains an electronic digital code; this code must be recognised by the system before the ignition system will function.

Thus the scooter has two forms of security – the key must physically operate the lock (in the normal way), and the electronic code must be recognised by the system. In this way the scooter is safe against having the ignition switch forced, or being hot-wired.

Main components

Special keys, with built in transponders.

The red key is the “master” key, which is used for programming, with the transponder mounted in a flip-out section.

The blue key(s) is for normal use.

Decoder, which uses the antenna to read the electronic code of the key transponder.

CDI unit, which latches to the ON position only if an appropriate signal is received from the decoder.

Other components

Antenna, located encircling the ignition switch.

7.5 amp fuse, which supplies +12V DC to the voltage stabiliser (located within the decoder box).

Voltage stabiliser (located within the decoder box), whose output (+12V DC) supplies power to the decoder and the CDI unit via contacts in the ignition switch.

“**Serial Line**”, connects the decoder to the CDI unit, and conveys the authorising signal enabling the CDI to latch to the “ON” position.

Diagnostic test socket under the helmet holding compartment.

Normal Operation

The key grip contains a passive electronic transponder – a device that contains a unique pre-set digital code, which can be read without direct electrical contact (similar to those used in the Datatag system). The keys do not need any power and they do not contain a battery.

When the ignition switch is turned on, the decoder interrogates the key’s transponder.

Only if the decoder recognises the transponder’s electronic digital code will it send a signal via the serial line to the CDI unit, enabling the otherwise conventional ignition system (alternator with pick-up and charger coil, CDI unit and HT coil) to function.

However, the CDI unit and the decoder are also programmed to operate together as a matched pair; if they detect a mismatch the CDI unit will not allow ignition.

To check the correct operation of the system

IT IS IMPORTANT THAT ON PDI AND AFTER ANY WORK ON THE IMMOBILISER SYSTEM, THE CORRECT OPERATION OF THE SYSTEM IS CHECKED.

- Insert the red key with the hinged transponder in the flipped out position (this takes it out of radio range of the antenna, thus enabling the system to be tested without the antenna automatically picking up a code).
- Turn the ignition on and try to start the engine. IT SHOULD NOT START.
- Insert the blue key and try to start the engine. IT SHOULD START AND RUN NORMALLY.

Fault finding points to note

Decoder and CDI units are initially manufactured as blank units. In this state ("Virgin") and up to the time they are programmed the immobiliser system will not offer any protection, and the ignition will function in a conventional way. However, a "virgin" unit can be used as a substitute to aid in fault finding.

Programming functions can only be done with a red key. Once either the decoder or the CDI unit has been programmed using a red key, they will only ever recognise that particular red key.

Therefore, it is vital that you USE ONLY THE BLUE KEY FOR ALL TESTING PURPOSES other than the programming procedure itself.

Diagnostic test procedure

If there is any fault with the system, the Immobiliser Test Box should be plugged in to the diagnostic test socket. The test box (Part no 020319Y, Current dealer price £53.99 + VAT) is an invaluable, time saving tool, and one which without doubt should be owned by all dealers.

Proceed as follows-

- With ignition off, turn on and wait for 'On' and 'Pronto' LEDs to illuminate.
- Turn ignition on. The 'Seriale' LED will flash, showing the signal on the Serial line.
- After a few seconds the appropriate LED will indicate the result of the diagnostic tests.

If the "No Serial line" LED lights up, it may be for the following reasons-

Serial Line circuit is broken.
Decoder is faulty
CDI unit is faulty

However if no LEDs light up, it may be for the following reasons-

+12V DC power supply failure.
Decoder is faulty
CDI unit is faulty

Before re-testing, press the reset button.

Diagnostic points to note-

To check for +12V DC power supply failure, check 7.5 amp fuse, and that +12V DC is present on decoder terminals 3,5 and 8, and CDI unit terminal 1.

The CDI unit does not have its own earth lead, but is earthed to the alternator stator back-plate via the white wire from terminal W. However, note also that back-plate and the engine itself is only earthed via the electric starter motor lead. The decoder has its own earth lead.

There are two different types of transponder/decoder system; each type is not compatible with the other. However this problem should only show up when trying to program new blue keys. In this case most automotive locksmiths will be able to “clone” a new blue key if they are provide with a functioning red key. These “cloned” keys will be recognised by the system without the need for programming.

Component replacement procedure

Component to be replaced	Action
Blue key	Follow programming procedure (pages 4-14,4-15 in SSM)- 1. Turn the ignition ON using the red key. After 1 to 3 seconds turn OFF. 2. Within 10 seconds turn the ignition ON using a blue key. After 1 to 3 seconds turn OFF. 3. If needed, repeat step 2 up to seven times to program further spare keys. 4. Turn the ignition ON using the red key. After 1 to 3 seconds turn OFF.
Red key	Red key alone cannot be replaced. Follow appropriate replace lock set instructions
Lock set (if old red key available)	1. Replace lock set. 2. Swap red transponder from old key into new key. 3. Check for correct operation of system. 4. Program new blue key using above procedure.
Lock set (if old red key not available)	1. Replace lock set, decoder and CDI unit. 2. Check for correct operation of system. 3. Program system as per blue key procedure above.
Decoder	1. Replace decoder (CDI must also be replaced). 2. Check for correct operation of system. Note that with a virgin decoder the engine will start, but won't rev above 2,000rpm. 3. Program system as per blue key procedure above
CDI unit	1. Replace CDI unit (CDI can be replaced on its own). 2. Check for correct operation of system. Note that with a virgin CDI unit the engine will start and run normally, but the immobiliser system is inactive. 3. Program the CDI unit simply by turning on the ignition switch using the red key

When programming keys do not have more than one transponder type key on the key ring, as the decoder may pick-up both transponders.

VESPA ET4 IMMOBILIZER DIAGNOSTICS

When fault finding the ignition system on VESPA ET4, there is a very simple and quick check, which can be done to give the Immobiliser the 'all clear'. If you don't have the effort-saving Immobiliser Tester (part no. 020319Y) then insert a 12 Volt LED in the 2 pin socket (the blue/black lead is negative) located under the helmet compartment and switch on the ignition whilst observing the LED. Note that the LED marked **Seriale** on the Tester display shows this same signal.

It is advisable to get into the habit of using the blue key for all use and testing purposes other than the programming procedure itself.

Normally-Functioning Immobiliser

The signal for a normally functioning Immobiliser system is a quick flash (0.7 seconds) and then the LED remains off.

Immobilizer Fault-Finding

If the system is not functioning normally, it is recommended to obtain the Piaggio Immobiliser Tester. This is by far the easiest way to diagnose faults. However, if for some reason this is not available, fault finding can be done by observing the following.

Example Serial Line Signal

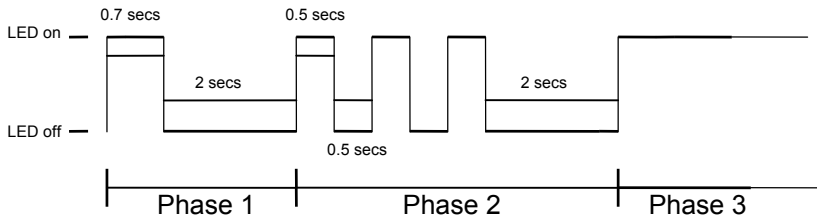

The above diagram shows the trace of the diagnostic signal for Decoder and CDI Units both programmed, using a key with an unknown transponder (Table 2, case 5), resulting in 3 FLASHES during the second phase of the diagnostic signal (Phase 2).

Phase 1: 0.7 sec flash = NORMAL OPERATION (Cases 7-14 in Table 2)
 2 sec flash = CDI Unit unprogrammed (Cases 1-6 in Table 2)
 BOTH of the above flashes will be followed by a 2-second pause.

Phase 2: A series of 0-4 flashes (0.5 sec each with 0.5 sec pauses) which form diagnostic signal (refer to Table 1).

Phase 3: LED remains OFF if no fault is detected or ON if a fault is detected in the Immobilizer system (the Tester does not consider a non-programmed CDI Unit a fault).

If the led does not light up at all try the following:

Possible Fault	Test
No power supply to Immobiliser circuitry in CDI	12 V. should show on blue lead (pin 1 of the CDI unit).
Faulty Decoder unit	Replace and test with BLUE KEY
Faulty CDI unit	Replace and test with BLUE KEY

Table 1: Immobilizer Diagnosis Chart

Phase 2 LED Signal	DIAGNOSIS
0 FLASHES	NORMAL OPERATION
1 FLASH	BREAK IN SERIAL LINE (ORANGE) OR DECODER EARTH (BLACK)
2 FLASHES	NO TRANSPONDER DETECTED - FAULTY KEY OR IMMOB. ANTENNA
3 FLASHES	TRANSPONDER DETECTED BUT NOT RECOGNISED BY IMMOB.
4 FLASHES	VIRGIN DECODER AND PROGRAMMED CDI UNIT

Table 2: Immobilizer Component Combinations and Related Diagnostic Signal

	Phase 1 Flash	Phase 2 Signal	Decoder	CDI Unit	Key Transponder	Antenna	Spark	Notes
1	2 sec	0 flashes	V	V	PRESENT - ANY	Y	✓	Note 1
2	2 sec	2 flashes	V	V	ABSENT or ANY	N	✓	Note 1
3	2 sec	0 flashes	P	V	PRESENT - PROG.	Y	✓	
4	2 sec	2 flashes	P	V	ANY	N	X	
5	2 sec	3 flashes	P	V	PRESENT - UNKNOWN	Y	X	
6	2 sec	2 flashes	P	V	ABSENT	Y or N	X	
7	0.7 sec	4 flashes	V	P	ANY	Y	✓	Notes 1,2
8	0.7 sec	2 flashes	V	P	ANY	N	X	
9	0.7 sec	2 flashes	V	P	ABSENT	Y or N	X	
10	0.7 sec	2 flashes	P	P	ABSENT	Y or N	X	
11	0.7 sec	2 flashes	P	P	ABSENT or UNKNOWN	N	X	
12	0.7 sec	3 flashes	P	P	PRESENT - UNKNOWN	Y	X	
13	0.7 sec	2 flashes	P	P	PRESENT - PROG.	N	X	
14	0.7 sec	0 flashes	P	P	PRESENT - PROG.	Y	✓	Note 3
15	N/A	1 flash	N/A	N/A	N/A	N/A	X	Note 4

KEY:

P = UNIT PROGRAMMED

V = VIRGIN i.e. UNPROGRAMMED

Y = ANTENNA FUNCTIONING

N = ANTENNA ABSENT or NOT FUNCTIONING

✓ = IGNITION POSSIBLE

X = IGNITION NOT POSSIBLE

PROG. = TRANSPONDER RECOGNISED THROUGH PROGRAMMING PROCEDURE

ANY = KEY WITH TRANSPONDER PRESENT BUT CODE DOESN'T MATTER

NOTES:

1. BLUE KEY - use for testing ignition after replacing Decoder and / or CDI Unit, otherwise you may sacrifice perfectly good units; programs both Decoder and CDI Unit.
RED KEY - only use for programming operations and ONLY when you are sure the ignition system is delivering a satisfactory spark.
The EXCEPTION to the above two points is when testing the Antenna with the RED KEY transponder flipped out, as per the ET4 Service Station Manual.
2. LIMITED TO 2000 rpm
3. Normal operation with the either key
4. Break in the Serial line (orange lead) or Decoder not earthed properly (black lead)

Vespa ET4 125 charge / ignition

Piaggio Ltd.

19/02/2003

ZAPM 04 Later version

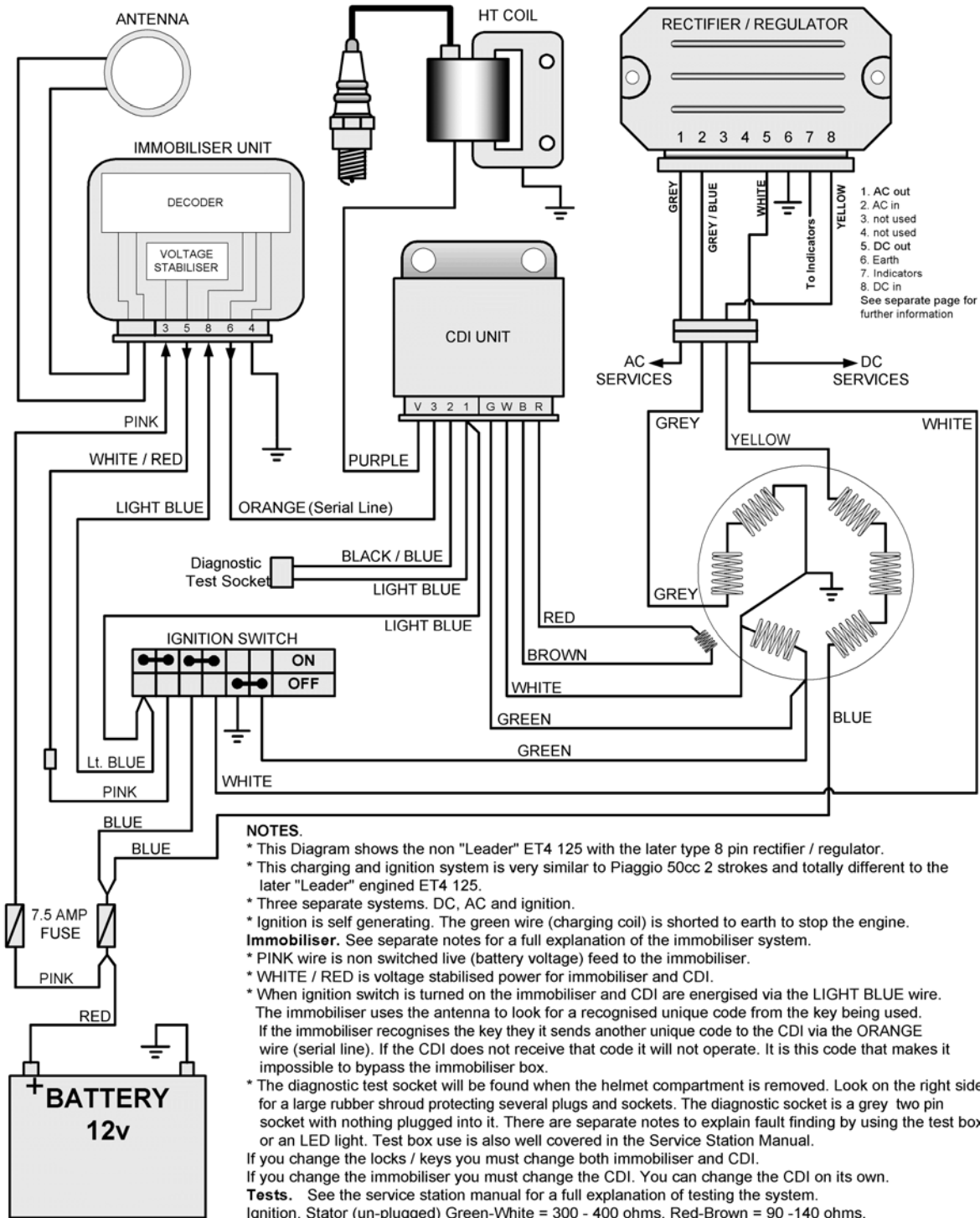

Vespa ET4 (ZAPM04) charging circuit

From ZAPM04 * 51160

07/08/2002

8 pin regulator

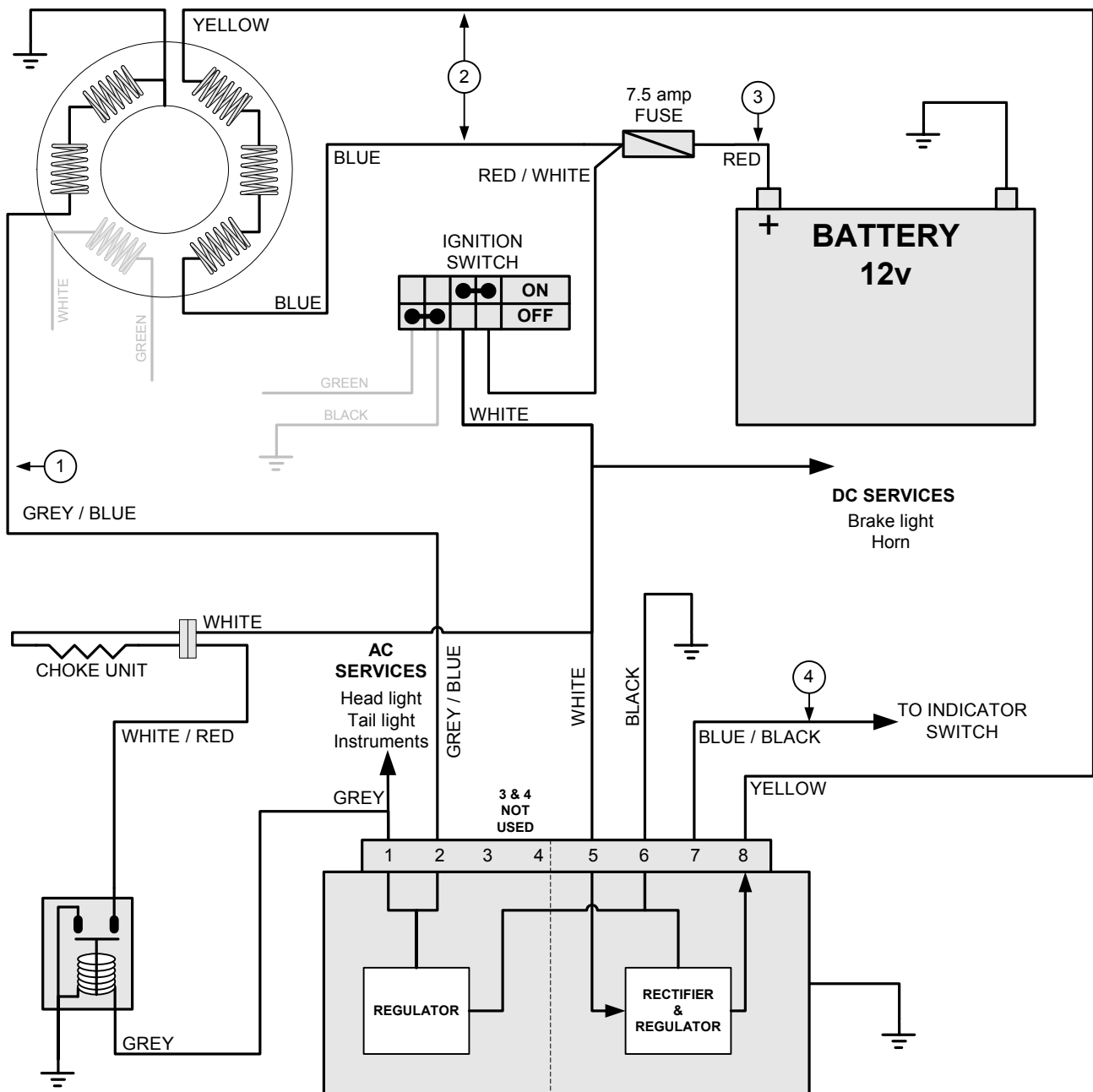

* This diagram shows the later (non Leader) ET4 wiring using an eight pin connector on the rectifier / regulator. Refer to the separate diagram for earlier circuit using a five pin rectifier / regulator.

* The charging system is basically the same as the 50cc & 80cc two stroke Sferoids.

* Two completely separate circuits for AC & DC.

* Eight pin rectifier / regulator incorporates the indicator relay.

* The choke is supplied with 12v DC when the ignition is turned on but the circuit to earth is only completed when the engine is running and 12v AC is supplied to the choke control relay.

TESTS.

1. Grey / Blue to earth = 25-30v AC stator un-plugged and engine at 2000rpm.

2. Yellow to Blue = 26-30v AC stator and battery disconnected and engine at 2000 rpm.

3. Ammeter between red wire and battery positive = 1.5-2 amp with fully charged battery and engine at 2000 rpm

4. Output to the indicator switch will be a 12v DC pulse with ignition on.

NOTES.

* Engine must be earthed to the chassis / battery. Lack of this connection will affect the AC circuit and starter motor but not the DC circuit or ignition circuit.

Vespa ET4 (ZAPM04) charging

Up to ZAP04 * 51159

07/08/2002

5 pin regulator

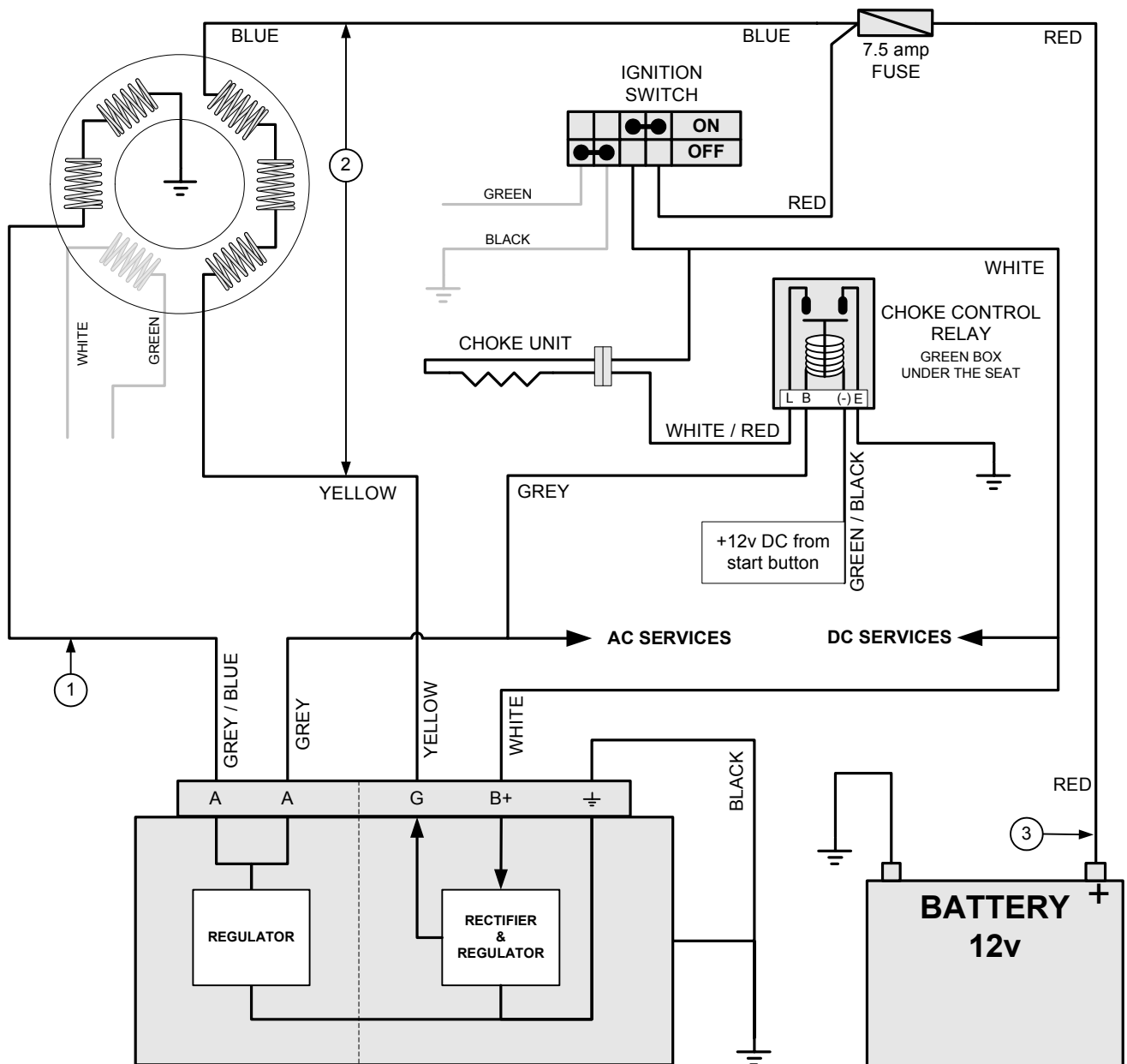

- * This diagram shows the early ET4 (non Leader) wiring using a five pin connector on the rectifier / regulator. Refer to the separate diagram for later circuit using an eight pin rectifier / regulator.
- * Three completely separate circuits for AC, DC & ignition.
 - AC is full wave and regulated
 - DC is half wave rectified and regulated
 - Ignition is the self powered CDI type typical on our two stroke scooters. Shorted to earth to stop.
- * Engine must be earthed to the chassis / battery. Lack of this connection will affect the AC circuit and starter motor but not the DC circuit or ignition circuit.
- * If voltage at the **B+** terminal falls below 8v (approx) the DC rectifier / regulator will not function so there will be no output from the alternator on the DC circuit.
- * Separate indicator relay.
- * The choke is powered by the DC circuit but the relay to activate it is controlled by the AC circuit. Circuit will only be completed when both:
 - AC is present at relay terminal "B" and +12v DC is NOT present at the unmarked terminal.

TESTS.

1. Grey / Blue to earth = 25-30v AC stator un-plugged and engine at 2000rpm.
2. Yellow to Blue = 26-30v AC stator and battery disconnected and engine at 2000 rpm.
3. Ammeter between red wire and battery positive = 1.5-2 amp with fully charged battery and engine at 2000 rpm

Coguar 125 Charging & Ignition

Piaggio Ltd.

07/08/2002

Honda XL125 engine

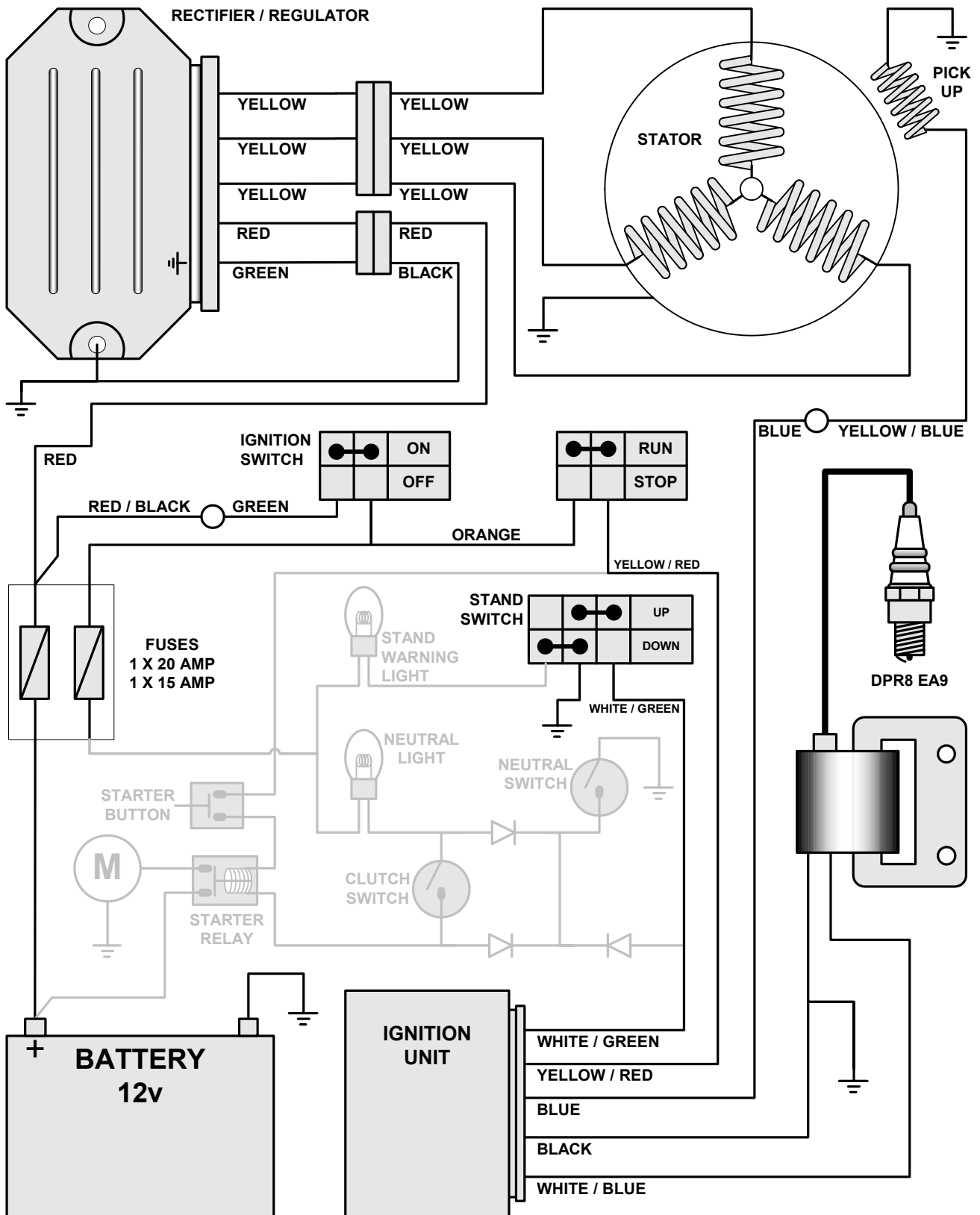

NOTES

Three phase charging with inductive low voltage ignition.

The start & run permissive circuit is shown here in grey.

TESTS

Stator: Any yellow to any yellow = 0.8 ohm. Any yellow to earth should give NO continuity.

Regulated voltage: 14.0 - 14.8 volts with fully charged battery and lights on. Engine running at 5000 rpm.

X9 250 FUSE EXPLANATION

Piaggio Ltd.

07/08/2002

Piaggio Ltd.

FUSES IN HELMET COMPARTMENT

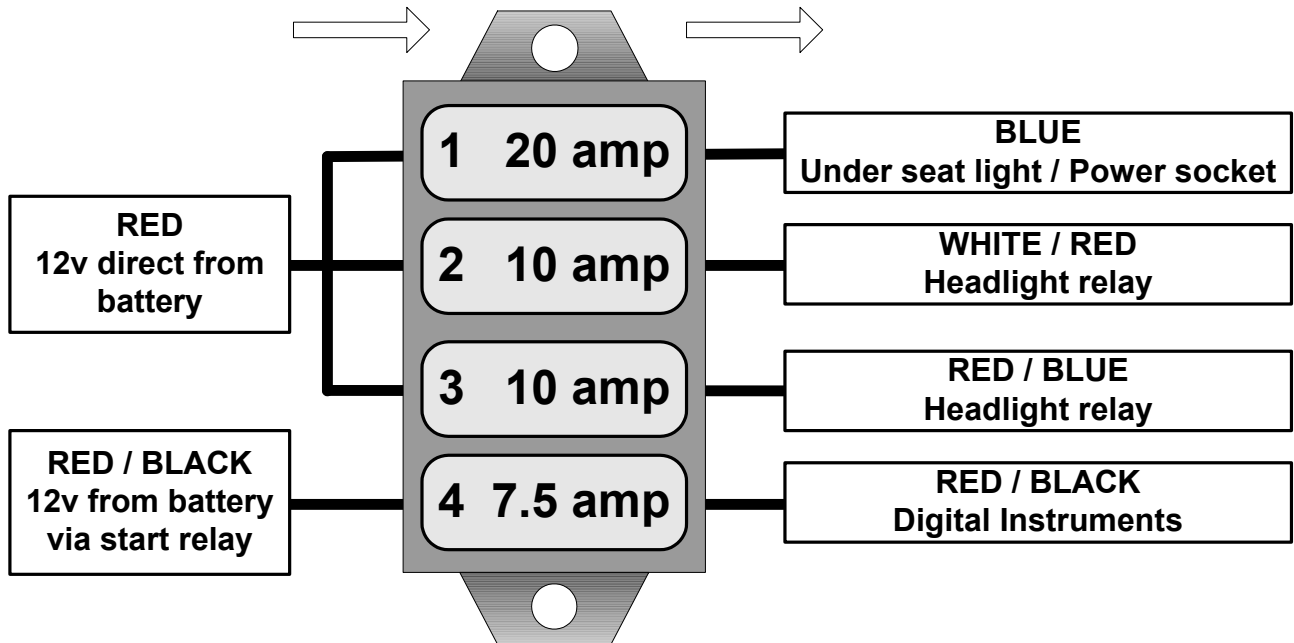

FUSES IN FRONT STORAGE COMPARTMENT

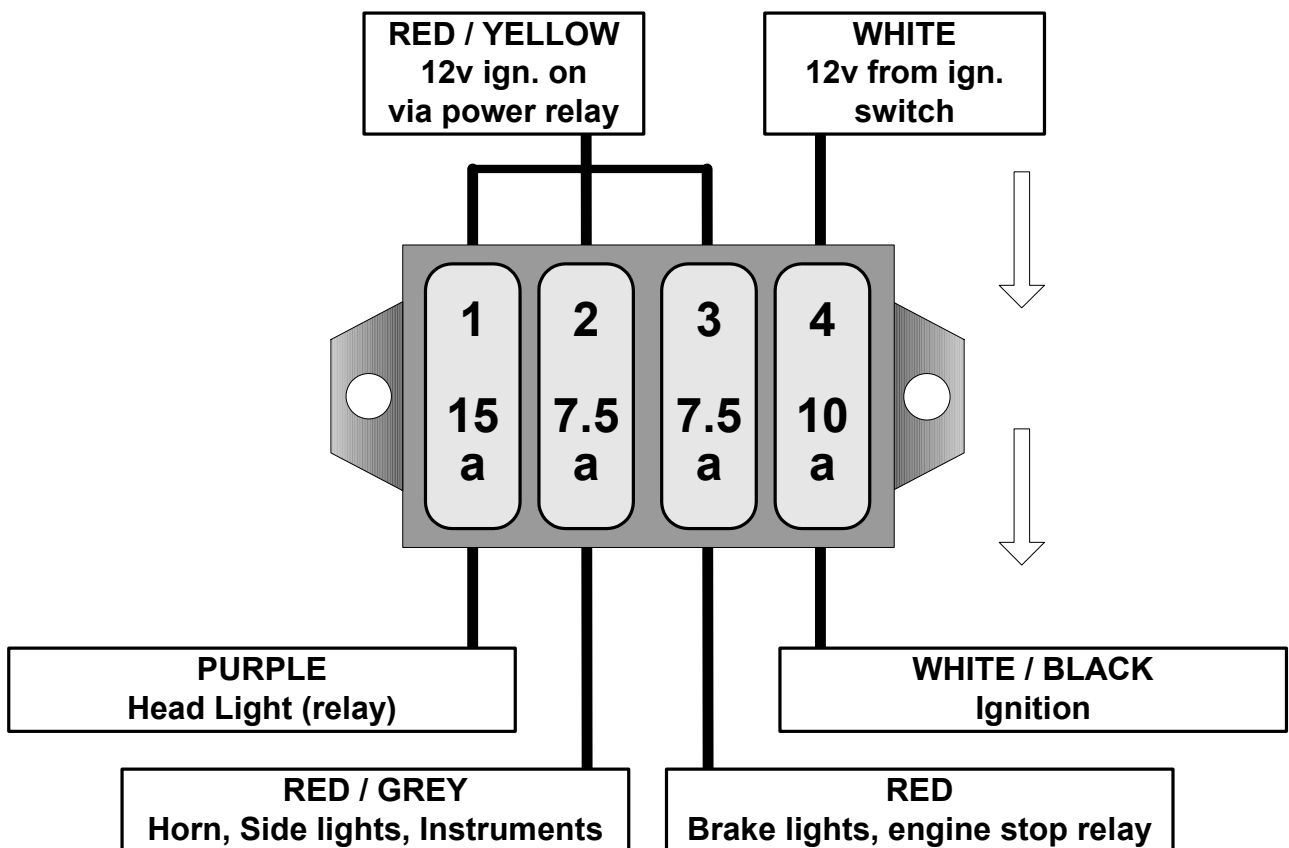

H@K & GSM Charging / Ignition

Piaggio Ltd.

23/04/02

Gilera engine

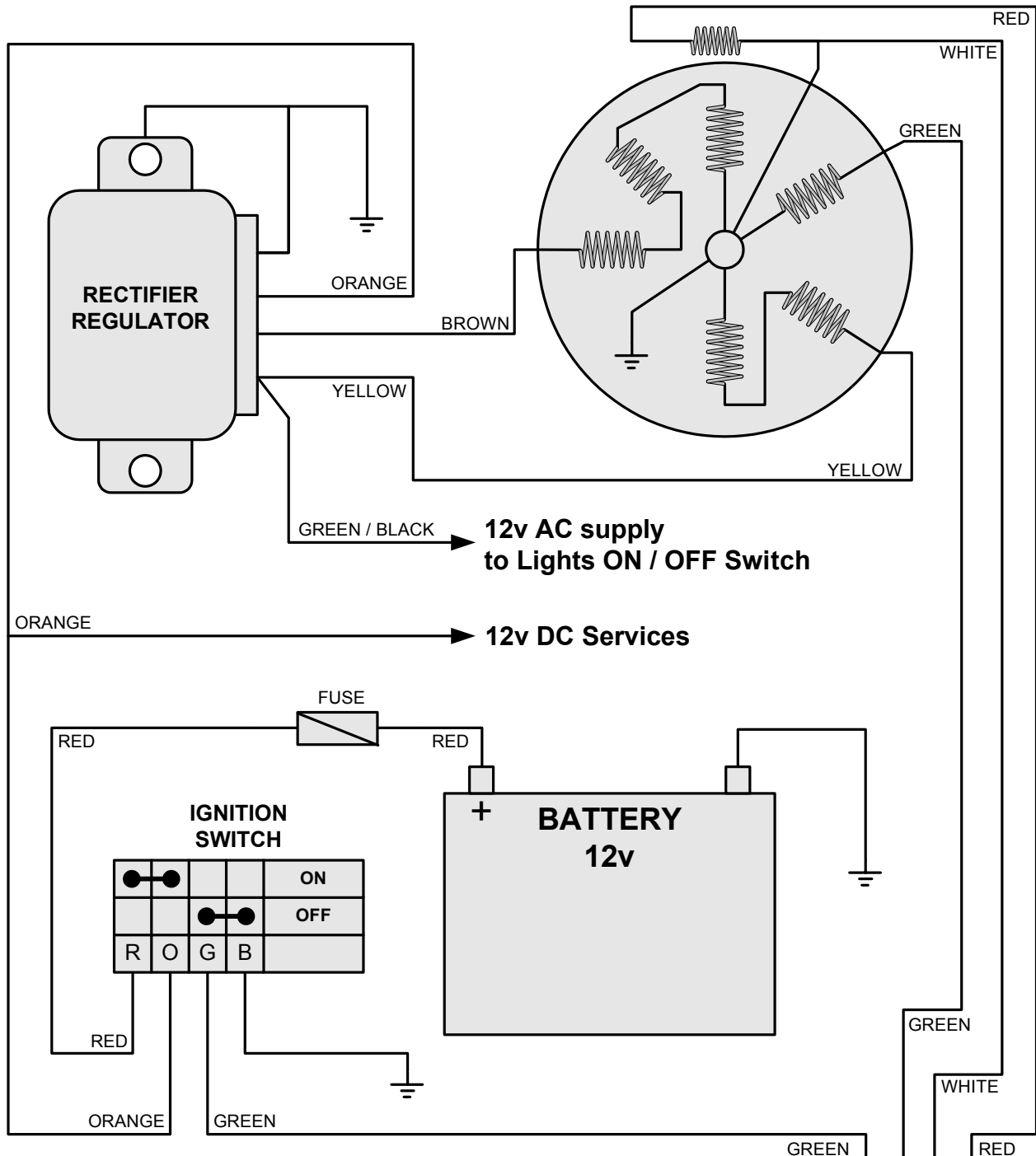

- * Stator has separate coils for AC, DC and Ignition circuits.
Brown wire = supply for DC (battery circuit)
Yellow wire = supply for AC circuit
Green wire = supply for ignition
- * Important that Stator has a good earth to engine and engine must have good earth to chassis and battery.
- * All Lights are powered by 12v AC
- * Ignition is self generating and does not need the other electrical circuits or the battery.
- * Ignition is stopped by shorting the charge coil (green wire) to earth.
Check: Unplug Green wire from stator and CDI unit. You should have continuity from green to earth with ignition OFF and no continuity with ignition ON.

Champion N2C
NGK BR9ES

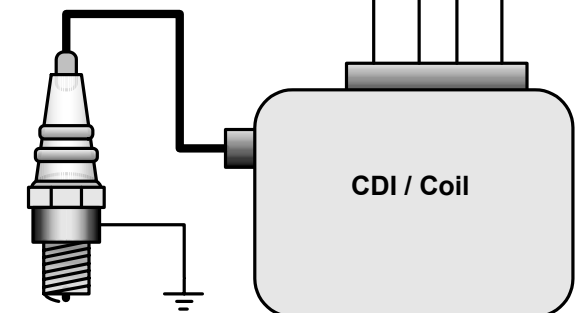

This information should not be used for Derbi Engine bikes

VESPA T5 HORN

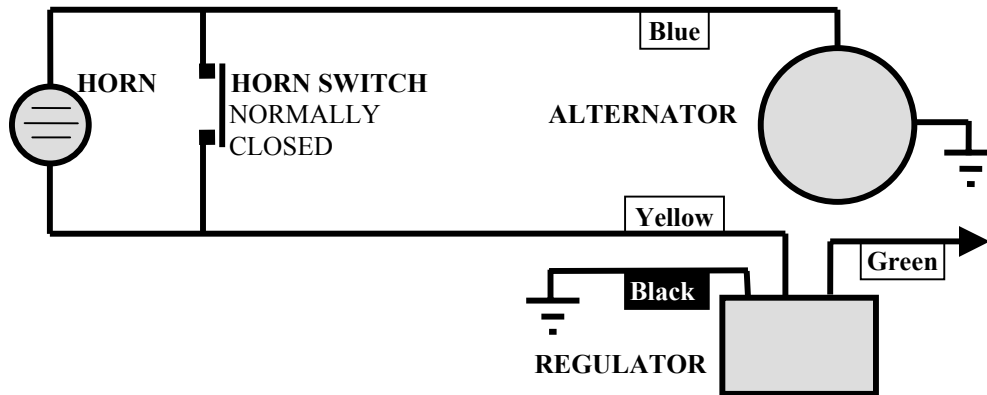

The T5 has a very simple 12 volt AC electrical system but one thing may not be clear when you look at the wiring diagram.

It appears that the output from the alternator goes firstly through the horn, this does not make much sense. If you are fault finding it is important that you understand how the system works.

Explanation:

1. Out put from the alternator is the **blue** wire to the horn switch.
2. Horn switch is **normally closed**.
3. From there the **yellow** wire continues to the regulator.
4. Electricity always takes the easy path, so the current passes through the switch rather than through the coil in the horn.
5. When the horn button is pressed and the circuit is broken and then the current will have to pass through the horn and the horn will sound.
6. Power still reaches the regulator because the horn does not use all the power available and it does not break the circuit.

Why is this unusual system used?

To ensure that all the current is available for the horn when it is operated. On any circuit the horn may not sound efficiently if it is supplied with low power.

PX 125 / 200E Indicator Circuit

Piaggio Ltd.

06/08/2002

Piaggio Ltd.

NOTE.

The indicators flash alternately; front - back (not both together)
This is to reduce the current needed

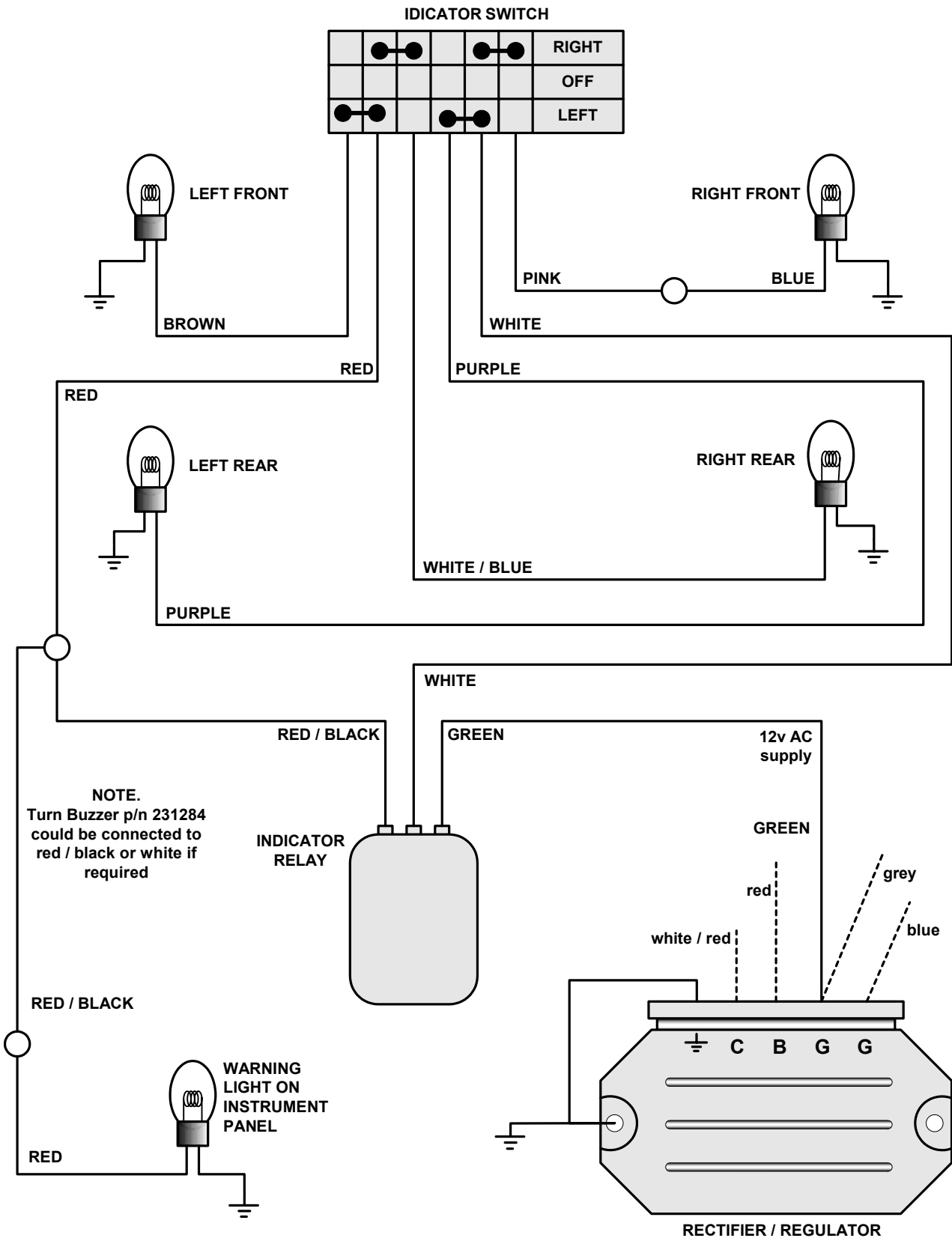

PX 200 / 125 Start Permissive circuit

Piaggio Ltd.

23/01/2003

Refer to Service Station Manual
578666 section 4

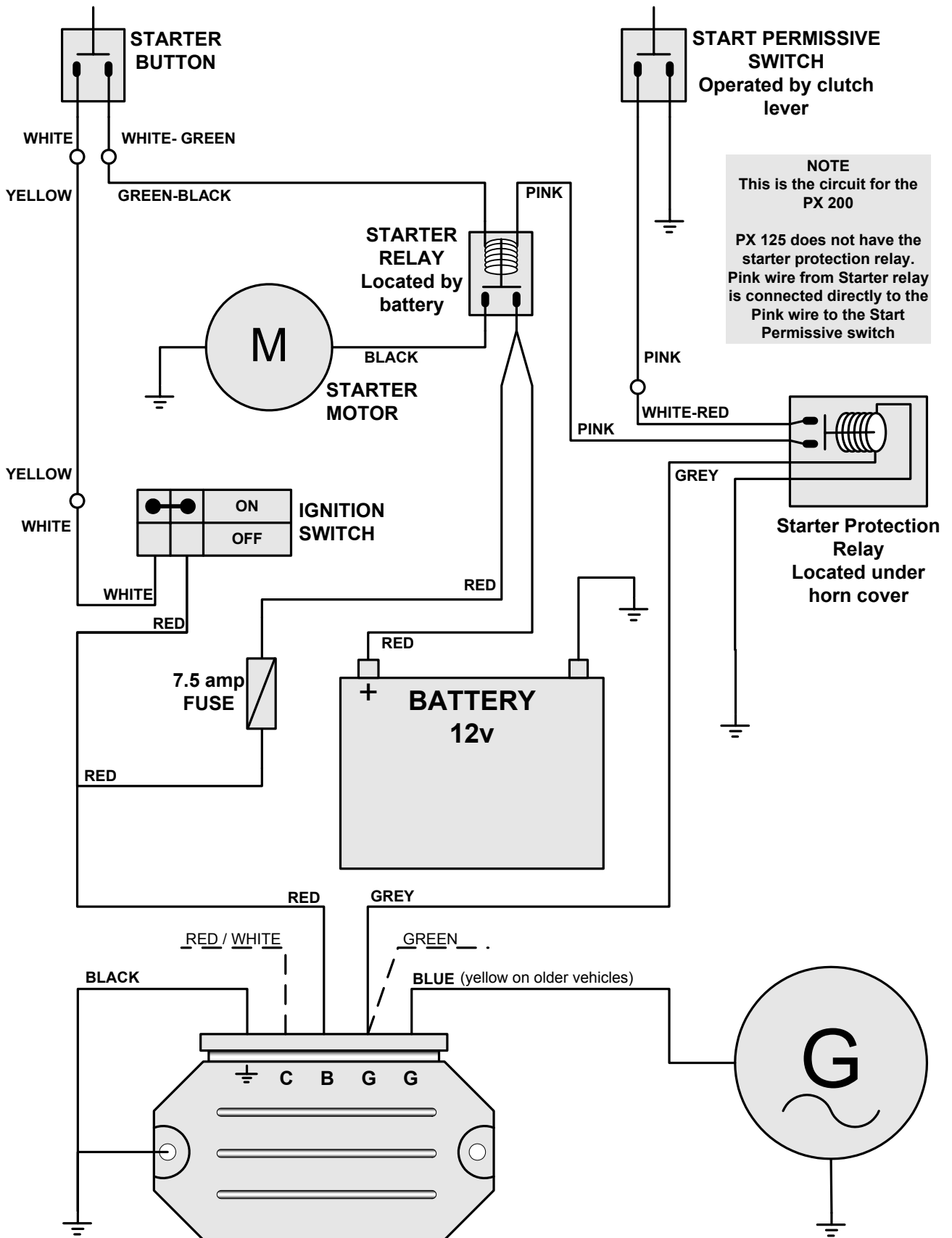

VESPA PX 125 / 200 Charging & Ignition

Piaggio Ltd.

04/07/02

Electronic Ignition

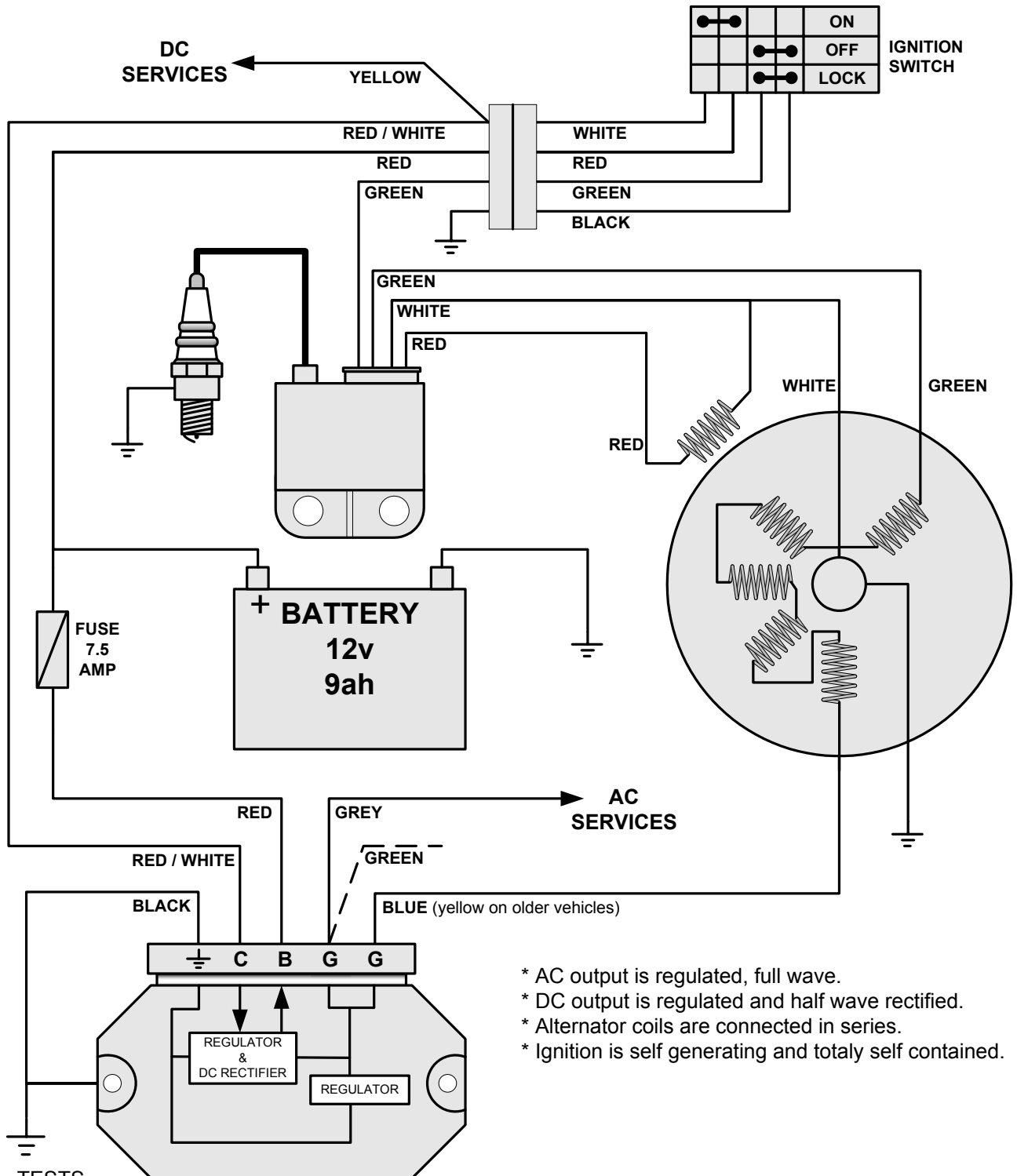

- * AC output is regulated, full wave.
- * DC output is regulated and half wave rectified.
- * Alternator coils are connected in series.
- * Ignition is self generating and totally self contained.

TESTS.

1. ALTERNATOR OUTPUT.

Unplug regulator. blue and earth = 26 - 30 vac @ 3000 rpm.

Unplug stator. red to white = 90 -140 ohms. green to white = 800 -1100 ohms.

2. BATTERY CHARGING.

Insert an ammeter between red wire and battery +.

With engine @ 3000 rpm and battery @ 13 vdc the ammeter should read 1.5 - 2 amps

* IN CASE OF OVER CHARGING.

un-plug the regulator and check that you have battery voltage on the red / white wire that plugs into terminal "C". The regulator needs this input to function correctly.

* Check for good earthing between engine and chassis / battery / regulator.

Wire diagram with indicators and electric starting

H@K & GSM
Gilera engine

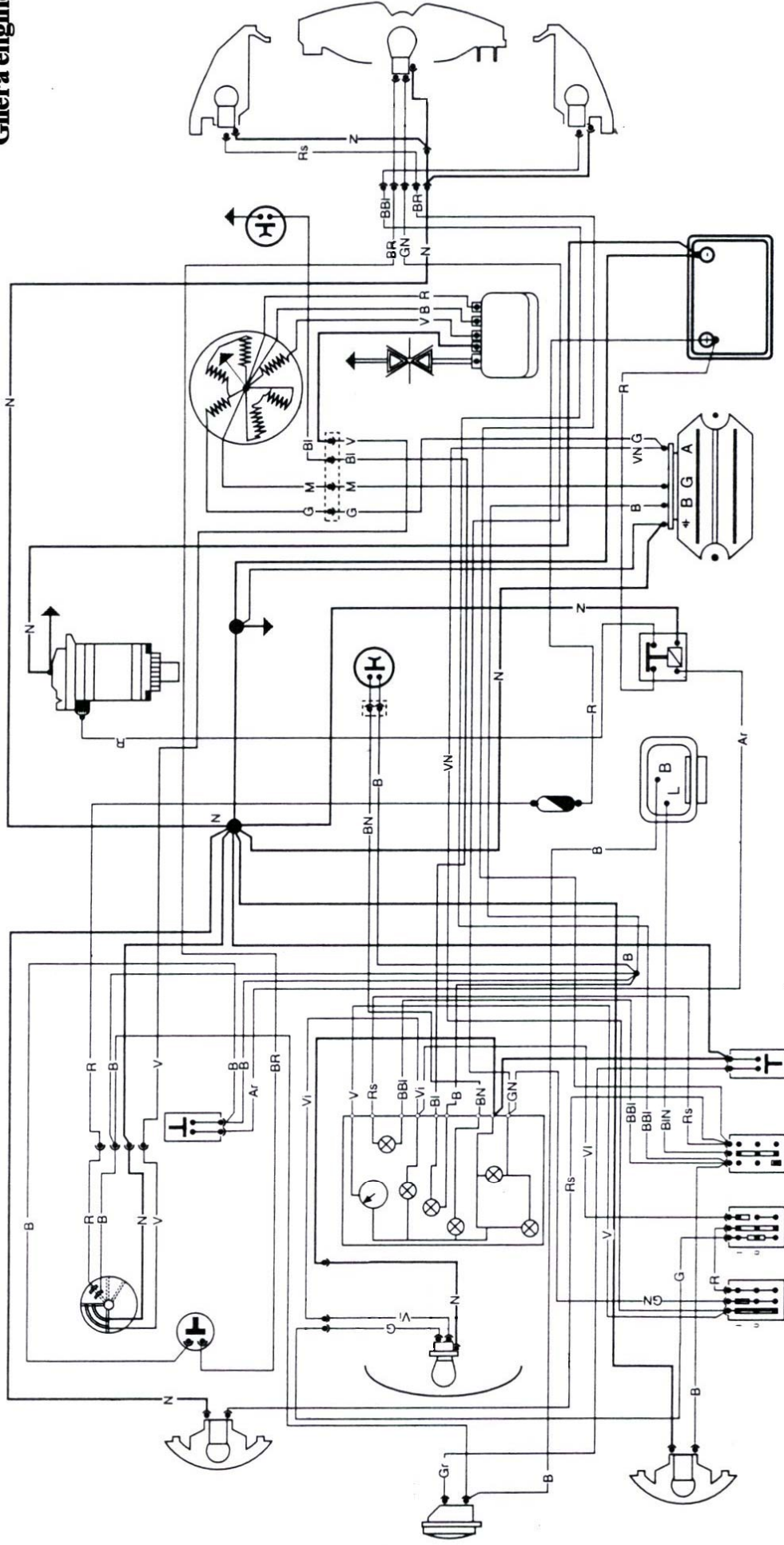

WIRE COLOUR CODING: **B**=White - **BI**=Blue - **G**=Yellow - **M**=Brown - **N**=Black - **BV**=White-Green - **GN**=Yellow-Black - **Gr**=Grey - **Rs**=Pink - **R**=Red - **Vi**=Purple - **V**=Green - **VN**=Green-Black - **BN**=White-Black - **BBI**=White-Black - **BV**=White-Blue - **GV**=Yellow-Green - **Ar**=Orange - **GrBI**=Grey-Blue - **GrN**=Grey-Black - **BR**=White-Red - **RN**=Red-Black - **BIN**=Blue-Black.

H@K & GSM Notes

Modifying the exhaust.

Piaggio can not recommend de-restricting for any reason. Be aware that if a moped is de-restricted then it becomes a 50cc motorcycle and should be re-registered. These vehicles may not conform to the requirements to become a motorcycle.

Un-officially and to save possible damaging experimentation the following information is given.

Enlarge the hole in the end of the exhaust, where it plugs into the engine.

The end of the exhaust is a piece of mild steel bar with a small hole drilled through it, this hole needs enlarging to about 18 - 20mm (3/4 inch).

The steel bar is case hardened to comply with "anti-tamper legislation". To soften the hardening; heat the end to bright cherry red and then let it cool naturally. Then you should be able to drill it.

Re-jet with a #60 or 62 main jet. It is a standard DellOrto jet.

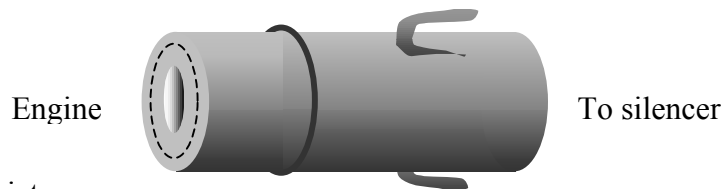

Useful contacts for jets are:

Contact Developments 0118-943-1180

VE (Malossi) 011594-62991

ENGINE CUTTING OUT OR FAILURE TO START IN WET WEATHER

1. Check plugs and sockets, grease when re-assembling.
2. Check float bowl for water. Rain can get into the air box especially if vehicle is parked. Water can then run into the carburetor and ultimately fill the float bowl. Drill a small hole in bottom of air box to let any water out and use silicon to seal the air box cover.

ENGINE CUTS OUT, THEN WILL RE-START AFTER A FEW MINUTES.

Most likely in cool and or damp weather, early morning , late evening.

Suspect; Carburetor Icing.

Carburetor has a warm water supply but the engine must be hot before this can function.

Check thermostat is closing. Look for water in air box (see note above). Blank off bottom 1/3rd of the radiator to help engine reach temp' and run warmer during the winter.

- Headlight is 35 / 35 halogen, giving main and dip. No side / parking light is fitted. All the lights run from 12 volt AC supply.
- Tail light is a conventional single 12v 21/5w bulb.
- Spark plug is Champion N2C or NGK BR9ES. Should give no problem in normal use.
- The tyre tread pattern on GSM is the opposite way round on front and rear.
- Non-cat exhaust is 813888. It has a washer tack welded into exhaust, this is easily removed. Fit larger main jet p/n. 813171
- H@K green is 431 "Aprile Green" Note that only the frame is painted.
- GSM grey is PM 2/6. Note that only the frame is painted.
- Rotor puller tool part number is 020581Y.

Gilera RCR 50 Charging / Ignition

Piaggio Ltd.

09/09/2003

Derbi engine

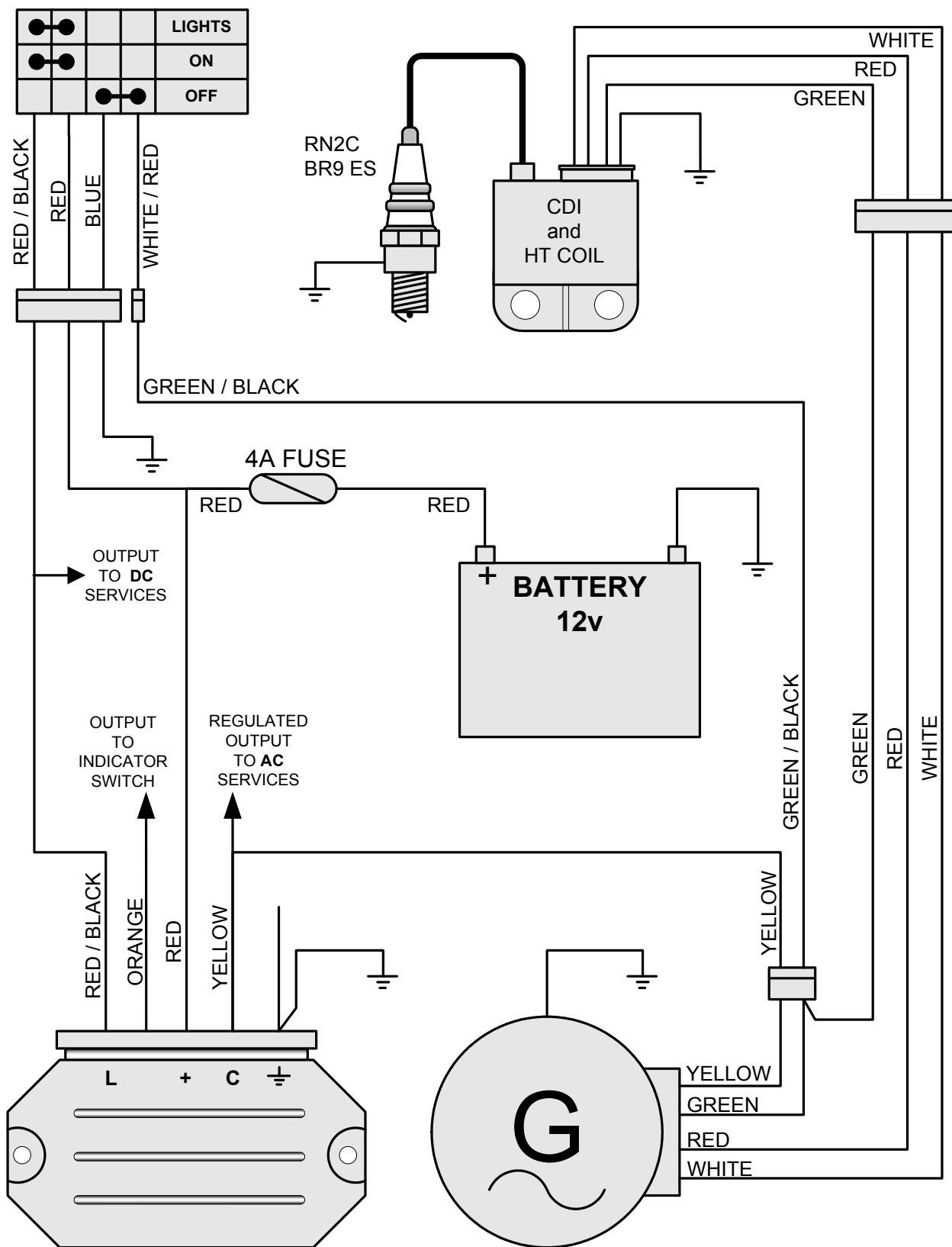

The Derbi electrics are arranged differently to Piaggio systems. Please study this carefully.
 Earth wires are: YELLOW / GREEN.
 Ignition is separate to AC & DC circuits. Ignition is shorted to earth to stop the engine.
 STATOR OUTPUT. GREEN to EARTH = 610 ohms \pm 10% (CDI charging coil)
 RED to EARTH = 80 ohms \pm 10% (Ignition pick up coil)
 YELLOW to EARTH = 0.9 ohm \pm 10% (AC & DC circuit charging coil)
 HT COIL secondary. 3.4 K Ohms \pm 15%. PLUG CAP. 5 K OHMS \pm 15%

X9 RANGE.

CHANGING THE ODDOMETER DISPLAY TO SHOW MILES

This should be done at PDI. See manual 594284. Pages 9-4 and 4-57

1. Press and hold the TRIP and M buttons.
2. Turn on the ignition.
3. Release the buttons

The display will now show "miles".

SERVICE LIGHTS

The time and date functions should be set at PDI to ensure that the service lights will come on at the correct time. Service Station Manual 594284 4-61 and owners hand books have details for setting the clock.

RE-SETTING THE SERVICE LIGHTS

If one or more of the service lights is flashing follow this procedure:

1. Remove the central panel between the headlights, this is retained by 5 cross head screws.
2. You will find a button above the headlight unit marked "RES"
3. Turn on the ignition. One of the three service lights is flashing.
4. Briefly press the button. The light before the one you want to reset should light.
5. Press and hold the button. The light you want to reset will start flashing faster. While it is flashing fast release the button. Now the light should have gone out.
6. Turn off the ignition and turn back on to prove the light has been cancelled.

If you have another light to reset; repeat the above steps.

If when you briefly press the button the light that comes on is not the one before the one you want to reset then briefly press the button again to make the light scroll along.

Wiring to the "RES" button is Grey/Green and Black. Grey/Green goes to the digital instrument panel and Black is to earth.

Service Station Manual for 125/180 (594284 1st update) page 4-59 has complete details.

Service Station Manual for 500 chassis (594523) page 4-15 has complete details.

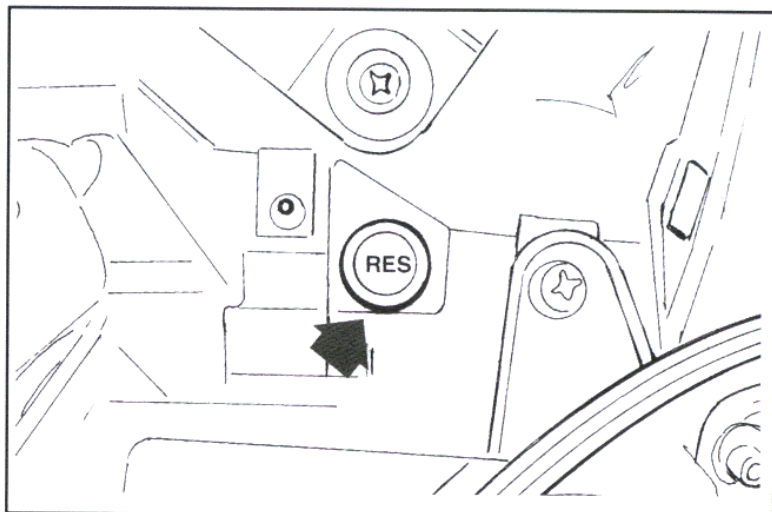

X9 UNDER THE FRONT PANEL

The front panel between the headlights is retained by five cross head screws. Remove the panel to access the service light reset button and the two headlight relays.

It is not necessary to remove the panel to adjust the headlight beam. The adjuster screw can be accessed through the small grill near the top of the panel.



SERVICE LIGHTS

The time and date functions should be set at PDI to ensure that the service lights will come on at the correct time. Service Station Manual 594284 4-61 and owners hand books have details for setting the clock.

RE-SETTING THE SERVICE LIGHTS

If one or more of the service lights is flashing follow this procedure:

1. Turn on the ignition. One of the three service lights is flashing.
2. Briefly press the button. The light before the one you want to reset should light.
3. Press and hold the button. The light you want to reset will start flashing faster. While it is flashing fast release the button. Now the light should have gone out.
4. Turn off the ignition and turn back on to prove the light has been cancelled.

If you have another light to reset; repeat the above steps.

If when you briefly press the button the light that comes on is not the one before the one you want to reset then briefly press the button again to make the light scroll along.

Wiring to the "RES" button is Grey/Green and Black. Grey/Green goes to the digital instrument panel and Black is to earth.

Fuel Gauge & Sender Circuit

Piaggio Ltd

04/11/2002

Piaggio Ltd

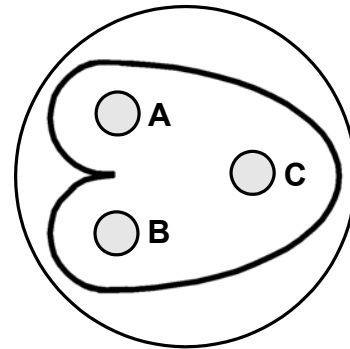
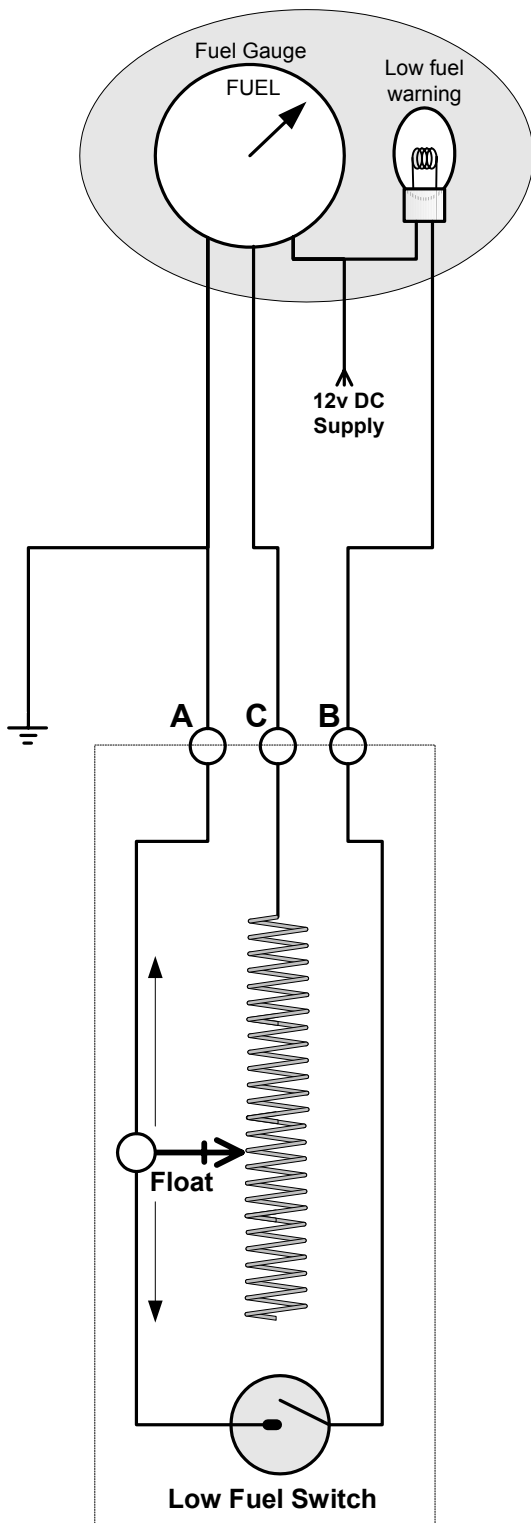

Top view of fuel sender unit socket

The fuel sender units on our automatic scooters may look different but the circuit and method of operation is always basically the same.

Vehicles without a fuel gauge have a low fuel warning light. They will have a two pin wiring connector. The wiring logic will be the same.

Remember that the power is supplied to the instrument panel and the tank unit is earthing it rather than sending power to the instruments.

WIRING

A = BLACK

B = GREEN / YELLOW

C = GREEN / WHITE

TESTS

A - C

Low fuel level \gg 100 ohms

High fuel level \gg 3 ohms

A - B

Low fuel level = 0 ohms

High fuel level = open circuit

Piaggio, Vespa, Gilera

AUTOMATIC CHOKE OPERATION

The automatic choke units used on Piaggio scooters are all basically the same and all work in the same way.

Remember that the choke defaults to being **ON** so it is unlikely that a cold starting problem is due to a malfunctioning choke.

Operation.

- The choke unit has a plunger that is pushed down to close off a hole at the bottom of a drilling in the carburettor.
- A wax pellet is heated electrically and expands, as it heats up it pushes out the plunger. As the wax warms the electrical resistance measured across it increases until it becomes open circuit. In most circumstances the choke will then remain off purely by the heat of the engine.
- The time taken for the choke to turn off is controlled only by the rate at which the wax expands. The ambient temperature will affect the time taken for the choke to turn off. Cold weather will mean the choke stays on longer etc.
- The choke is activated once the engine has started and **not** when the ignition is turned on.

50 & 80 cc two stroke engines.

These scooters have headlights that are run from 12 volts AC.

12 volts AC is used to operate the choke. AC can only be supplied when the engine is running so the choke can not begin to turn off until the engine is running.

125 & 180 cc two stroke engines.

These engines have an all 12 volt DC system.

When the ignition is turned on there is 12 volts supplied to the choke but the circuit is not completed to earth and no current can flow. So the choke will not turn off if the ignition is left on before starting the engine.

When the engine starts the rectifier / regulator completes the circuit to earth (via the grey wire) and the choke will turn off during the next few minutes.

125 four stroke engines. (not Leader)

Sfera 125 uses an AC system like the 50 / 80 cc engines.

ET4 employs a relay so that the choke will be powered by DC but is triggered by the AC supply when the engine starts.

Leader four stroke engines.

These engines have an all 12 volt DC system.

When the ignition is turned on there is 12 volts supplied to the choke but the circuit is not completed to earth and no current can flow. So the choke will not turn off if the ignition is left on before starting the engine.

When the engine starts the CDI unit completes the circuit to earth (via the white / black wire) and the choke will turn off during the next few minutes.

50 four stroke.

Connected to the AC output from the rectifier / regulator so power is only available when the engine is running.

250 Hexagon & X9 250 (Honda engines).

AC powered by one of the three phase (yellow) wires direct from the generator.

Faults.

The most likely fault is the choke remaining ON. Symptoms will be anything that may be caused by a rich mixture.

1. High fuel consumption.
2. Black spark plug.
3. Rough running when hot. OK when ridden hard but rough and four stroking at 20 mph.
4. Fails to start. Plug is found to be black and fouled.

To check the choke unit is operating.

Refer to diagram 1.

1. Remove choke unit from the carburettor.
2. Measure the distance the plunger is protruding from the body, when it is cold.
3. Attach a 12 volt battery to the socket and leave it for a two or three minutes.
4. The plunger should have extended by 4-5 mm.
5. Disconnect the battery.
6. The plunger should retract slowly over a couple of minutes.

Dia.1. Choke unit operation.

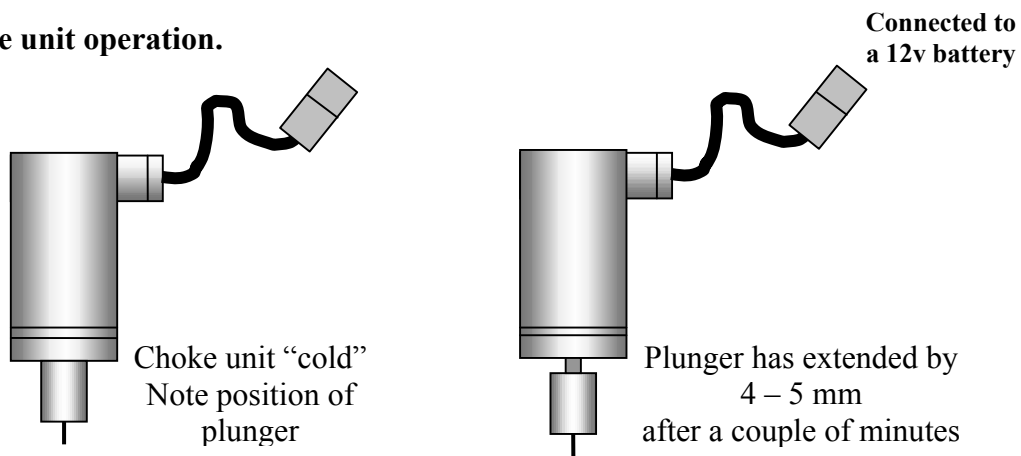

To check the choke circuit.

Refer to diagram 2.

1. Follow wire from the choke unit until you find a grey two pin plug and socket. Unplug.
2. Resistance check will confirm continuity through the choke unit.
3. To prove the choke circuit. Connect a voltmeter across the two pins of the socket. With the engine running you should have 12-14.5 volts (AC or DC depending on the engine type, see the notes above). If no voltage then the choke will not turn off.

Note. Remember that the choke defaults to being ON. If the choke does not turn off the symptom will be a black and fouled plug. Or; The scooter starts and idles ok and runs at speed ok. When riding slowly (15 - 20 mph) the engine runs very roughly.

Dia.2. Choke unit power supply.

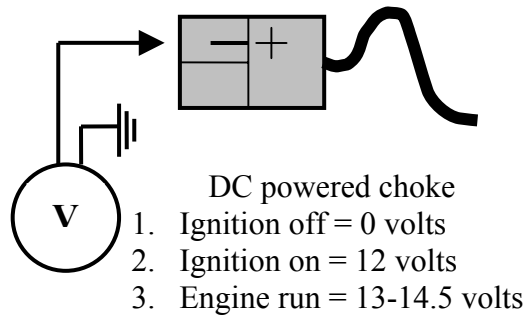
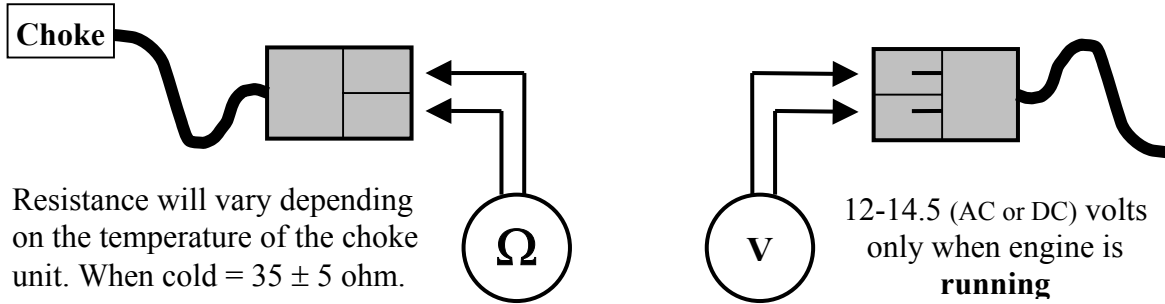

Note. Choke units all look much the same but are different and it is important to use the correct choke in the correct carburettor.

STATOR COIL VALUES

Refer to the relevant Service Station Manual / wiring diagram

Vehicle	Ign. Pick Up ①	Ign. Charging ①	AC Circuit	DC Circuit	
50cc 2T	Red - White 88 Ω (± 5 Ω)	Green - White 970 Ω (± 50 Ω)	Blue / Grey - Earth 25 - 30v AC ②	Yellow - Blue 25 - 30v AC ③	Red - Battery Positive 1.5 - 2 amp (charged bat.=13v)
Runner 125 Hexagon 2T	Red - Brown 90 - 140 Ω	Green - White 50 - 150 Ω	n/a	Yellow - Yellow 27 - 30v AC ②	
Liberty 125 ET4 original	Red - Brown 100 - 130 Ω	Green - White 300 - 400 Ω	Blue / Grey - Earth 25 - 30v AC ②	Yellow - Red 26 - 30v AC ③	Red - Battery Positive 1.5 - 2 amp (charged bat.=13v)
Skipper 2T Typhoon 125	Red - Brown 90 - 140 Ω	Green - White 100 - 160 Ω	n/a	Yellow - Yellow 27 - 30v AC ②	
Leader (all) 125 / 180	Green - Black 105 - 124 Ω	n/a	n/a	Any yellow - yellow 0.7 - 0.9 Ω ① Yellow to earth = no continuity	
Hexagon 250 GT & GTX	Green / White - Blue / Yellow 50 - 170 Ω	n/a	n/a	Any yellow - yellow 0.1 - 1.0 Ω ① Yellow to earth = no continuity	
X9 250	White / Yellow - Yellow >> 200 Ω	n/a	n/a	Any yellow - yellow >> 0.6 Ω ① Yellow to earth = no continuity	
X9 500	Engine speed & position sensor Green-Black = 680 Ω ± 15% ④	n/a	n/a	Any yellow - yellow 0.2 - 1.0 Ω ① Yellow to earth = no continuity Battery charge > 20amps, lights on, high revs.	
PX125 / 200	Red - White 90 - 140 Ω	Green - White 800 - 1100 Ω	Blue - Earth 26 - 30v AC ②	Ammeter between red and battery positive. 1.5-2 amps @ 3000 rpm. (charged battery. i.e. 13v)	

- ① Test to be carried out with the stator un-plugged and engine stopped.
- ② Test to be carried out with rectifier / regulator disconnected and engine running.
- ③ Test to be carried out with rectifier / regulator and battery disconnected.
- ④ Test with unit unplugged.

INSTRUMENT PANEL DISPLAY

Several Piaggio vehicles now have electronic instruments. Please make sure you are familiar with their operation and settings.

B (Beverly)

Clock and trip counter will re-set if voltage drops below 4,5v. Total distance record is “non-volatile” and can not be affected.

Changing the odometer display to show miles.

1. Ignition off
2. Press and hold down the MODE and CLOCK buttons
3. Turn on the ignition
4. Miles or Km will be displayed to show which is selected. Turn off and start again to change it

DNA

Changing Km/h speedo and Km distance to MPH and Miles.

This should be done at PDI. See manual 564329 page 4-42. The manual says that the change can only be made if less than 6km show on the total distance. This is no longer true, the change can be made as often as needed at any distance.

1. Press and hold down the MODE and CLOCK buttons.
2. Turn on the ignition. The display will remain blank.
3. Wait until the display shows the letters “MPH”. Then you can release the buttons.
4. Wait for the instrument to go through the normal start up and you will notice that it now displays MPH.

ICE

Changing Km/h speedo and Km distance to MPH and Miles.

This should be done at PDI. See manual 564811 page 4-13.

1. Press and hold down the MODE and CLOCK buttons.
2. Turn on the ignition. The display will remain blank.
3. Wait until the display shows the letters “MPH”. Then you can release the buttons.
4. Wait for the instrument to go through the normal start up and you will notice that it now displays MPH.

X9

Clock.

The clock time and date functions MUST BE SET AT PDI. Because some of the service light intervals are controlled by this.

Changing the odometer display to show miles.

This should be done at PDI. See manual 594284. Pages 9-4 and 4-57

1. Press and hold the TRIP and M buttons.
2. Turn on the ignition.
3. Release the buttons

The display will now show “miles”.

X9 cont.

Service lights.

There are three lights on the display to remind the owner that certain servicing is due. These lights are controlled by elapsed mileage and elapsed time so it is important to set the date correctly at PDI. If you do not do this you may find the lights come on at the wrong time (and you will get a grumpy customer).

- OIL: Comes on after first 1000km (625 miles) and then after every 3000km
SERVICE: Comes on after first 1000km and then after every 6000km.
This light also comes on after one year even if the distance has not been covered.
BELT: Comes on after every 18000km.

Re-setting service lights.

If one or more of the service lights is flashing follow this procedure:

1. Remove the central panel between the headlights, 5 cross head screws retain this.
2. You will find a button above the headlight unit marked "RES"
3. Turn on the ignition. One of the three service lights is flashing.
4. Briefly press the button. The light before the one you want to reset should light. If the light that comes on is not the one before the one you want to reset then briefly press the button again to make the light scroll along. When you have the light before alight, then:
5. Press and hold the button. The light you want to reset will start flashing faster. While it is flashing fast release the button. Now the light should have gone out.
6. Turn off the ignition and turn back on to prove the light has been cancelled.

If you have another light to reset; repeat the above steps.

Don't forget to reset service lights when you do a service, even if they are not flashing (scooter has come in early). If you do not do it the customer will be back in a few days with a light flashing. That makes you look bad and again you have a grumpy customer.

It is probably worth going through the re-set procedure for all three lights at PDI because if the battery had been connected previously the counter will have started from the wrong day.

ZIP

The Zip now has electronic instruments. The speedometer is still the traditional analogue display but it is now electronically controlled. The odometer is now digital LCD. It is supplied showing the distance in Km. It can be changed to show miles but only if it is changed during the first 10km. CHANGE IT AT PDI.

Changing the odometer display to show miles.

1. Ignition off
2. Press and hold the button on top of the leg shield.
3. Turn on ignition. LCD display will show "Cont" (km) or "EnGL" (miles)
4. Briefly press button to toggle between the two alternatives.
5. When the correct press and hold the button for more than one second.
6. Turn ignition off. Turn back on to confirm the setting is now correct.

Re-setting the "Change Oil" warning.

At 6000km an oil change warning will be displayed on the LCD display for 10 seconds every time the ignition is turned on. Cancel this at service.

1. Press and hold the button at top of the leg shield.
2. Turn on ignition on.
3. Release button and turn ignition off. Turn ignition back on to check that the warning has been cancelled.

TYPHOON 80 - 125 FUEL SYSTEM

Piaggio Ltd.

07/08/2002

Piaggio Ltd.

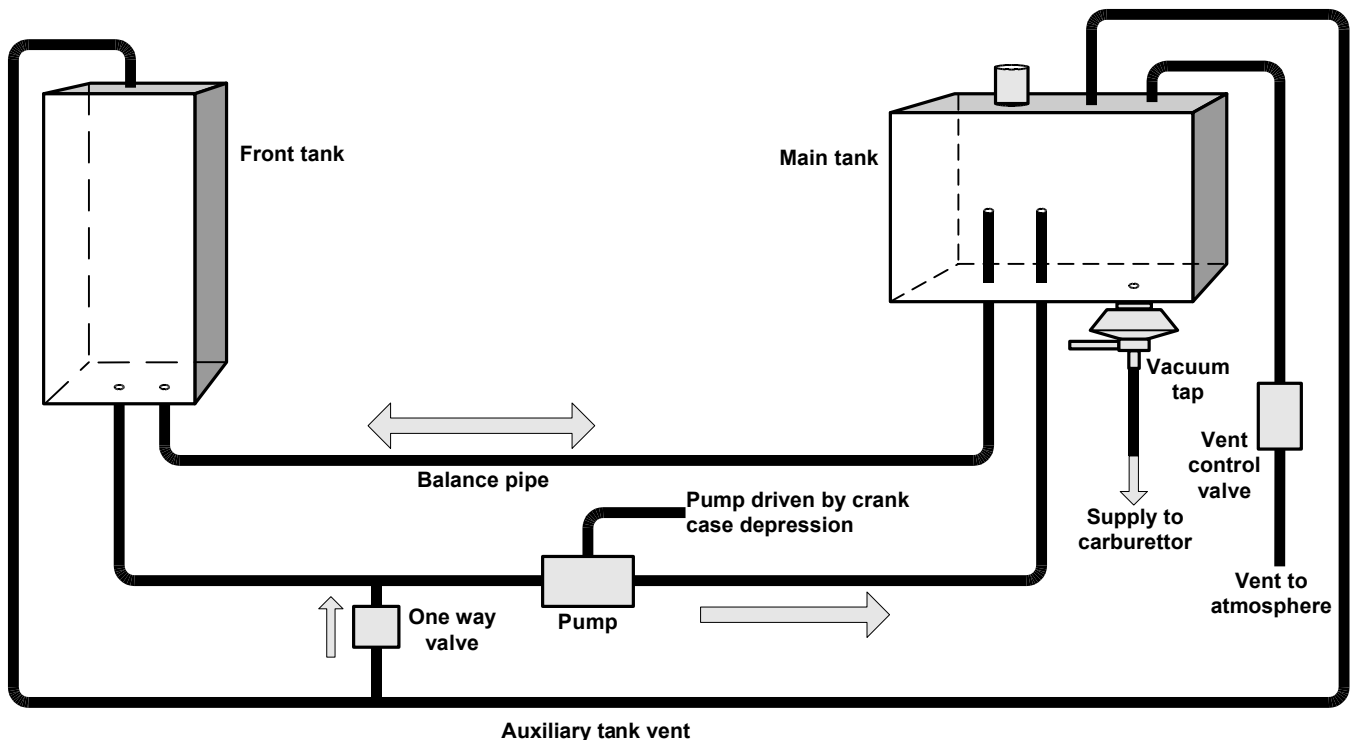

Typhoon 80 and 125 have an auxiliary fuel tank located under the front panel. The plumbing for this fuel system looks complicated. The Typhoon parts catalogue contains an illustration which should help you locate the components on the vehicle. The diagram above is intended to help explain the operation of the system and should prove useful when fault finding.

VENT TO ATMOSPHERE The system has only one vent which you will find exiting under the rear mudguard.

VENT CONTROL VALVE Controls venting to prevent loss of fuel from full tank. Air can enter the tank without restriction but a slight pressure is required before vapour can exit.

AUX TANK VENT Auxiliary tank vents to the main tank via a pipe that has to run under the foot boards. Because this pipe gets lower than the tank level it can become full of fuel and so the auxiliary tank will not vent. To prevent this a limited flow **ONE WAY VALVE** allows any fuel to be sucked out.

A large diameter **BALANCE PIPE** lets petrol flow between the two tanks.

A smaller diameter pipe passes through the **PETROL PUMP** which pumps petrol from the auxiliary tank to the main tank.

PETROL PUMP is driven by the vacuum/pressure pulses from the crank case.

Note that the **BALANCE PIPE** stands up into the main tank so once the fuel level reaches that point the pump will drain the auxiliary tank and all the remaining fuel will be in the main tank. Because of this layout the fuel gauge does not drop at a steady linear rate. If you start with a full tank, fuel is used in the following three phases:

1. Fuel used from main and auxiliary tanks equally - Gauge will drop from full to $\frac{1}{4}$.
2. Level remains constant in main tank while auxiliary is drained - Gauge remains at $\frac{1}{4}$.
3. Fuel is used only from main tank - Gauge drops from $\frac{1}{4}$ to empty.

VACUUM TAP is operated by vacuum from the inlet manifold.

TYPHOON 80 - 125 FUEL SYSTEM

Piaggio Ltd.

07/08/2002

Piaggio Ltd.

FAULT FINDING

If you suspect that the fault is due to lack of fuel. Firstly prove that the carburettor is running out of fuel.

Attach a piece of clear tube to the float bowl drain and turn it up the side of the carburettor.

Open the drain screw. you will now be able to view the fuel level. It should remain about 3.5mm below the float bowl joint. If you find it is low or it drops during running then you should explore the fuel supply.

If you have a problem that suggests a poor supply of fuel to the carburettor.

1. Check that you have fuel in the main tank. If you have fuel then you can forget about the front tank and its associated plumbing, this can not affect the supply to the carburettor.

Not able to get 7 litres of fuel in scooter with a nearly empty tank.

Auxiliary tank is not being used for some reason.

1. Check pump. With engine running you should see the pumped fuel coming out of the pipe in the main tank.
2. Check for pinched pipes particularly under foot boards and helmet compartment.
3. Check auxiliary tank vent is clear of fuel (one way valve not working).

Scooter cuts out probably through lack of fuel.

1. Check vent pipe is clear. Blow through it with filler cap removed.
2. In the vent pipe you will find a grey and orange valve. This is a flow control valve. It should offer no resistance to air entering the tank and some resistance should be felt if you blow through it from the tank side.

Do not drill a hole in the filler cap to cure a venting problem.

Fuel comes out of vent when scooter is parked in sun or on a slope.

1. Vent pipe valve is faulty.
2. Early 80's did not have this valve, a modification kit is available from Piaggio.

Scooter runs ok on bench but customer says it cuts out when ridden.

1. Pipe trapped under helmet compartment is squashed by weight of rider.

PUMPED FUEL SYSTEMS

Explanation of differences on Piaggio and Gilera scooters

These scooters all have a pumped fuel supply:

DNA 50.	ZAPC27	Hexagon 250 GT.	ZAPM14	Runner VXR.	ZAPM24
DNA 125.	ZAPM26	Hexagon GTX 125	ZAPM20	Typhoon 80	TE81T
DNA 180.	ZAPM26	Runner 50	ZAPC14	Typhoon 125	ZAPM02
Hexagon 125.	EXS1T	Runner FX.	ZAPM07	X9 125.	ZAPM23
Hexagon 125 LX.	ZAPM05	Runner FXR	ZAPM08	X9 250.	ZAPM23
Hexagon 180 LXT.	ZAPM06	Runner VX.	ZAPM24	X9 500	ZAPM27

DNA 50 2 stroke. TWO different fuel systems.

EARLY VEHICLES: Do not have a pressurised fuel system.

The pump operates by crankcase pressure/vacuum. It feeds fuel to a header tank that supplies the carburettor by gravity. Normal vacuum tap in header tank, vacuum from inlet manifold.

The return from the header to the main tank is not restricted and fuel circulates freely.

If the header tank is not full then a fuel supply problem must be suspected.

LATER VEHICLES: Have a pressurised fuel system.

The pump operates by crankcase pressure/vacuum. It feeds fuel directly to the carburettor. A vacuum tap is fitted to the bottom of the tank. This is opened by inlet manifold vacuum.

DNA 125 / 180 4 stroke. All have a pressurised fuel system.

Pump operates from inlet manifold vacuum.

Pump is attached to the bottom of the tank and supplies fuel directly to the carburettor via an inline fuel filter and a non return valve.

From late 2001 all vehicles had a vacuum tap fitted to the bottom of the tank. The tap is connected by a "T" piece to the vacuum pipe near the fuel pump.

Note that the early 180 also uses the vacuum line to supply vacuum to an over run valve on the carburettor.

HEXAGON 2 stroke. All have a pressurised fuel system. Pump operates by crankcase pressure/vacuum.

EXS1T early. Pump supplies fuel directly to the carburettor.

EXS1T late. Same as early system but with a header tank to ensure a head of fuel to help starting after a period. The header tank has a return pipe, the connector on the tank has a very small hole so system pressure is maintained, it is important this hole is not enlarged.

ZAPM05000 (125). Pump supplies fuel directly to the carburettor.

ZAPM06000 (180). Same as 125 but with a limited flow return that controls the supply pressure. This is a "T" piece in the carburettor supply pipe and a pipe that returns to the tank, there is a restrictor in that pipe to limit the return and maintain the system pressure. Refer to the separate sheet for a more detailed explanation (Hexagon LX / LXT fuel system)

HEXAGON 4 stroke. All have a pressurised fuel system.

GTX 125 / 180. Pump operates from inlet manifold vacuum.

Fuel is pumped direct to the carburettor.

GT 250. Electrically operated pump that is controlled by the ECU

RUNNER 2 stroke. Do not have a pressurised fuel system.

The pump operates by crankcase pressure/vacuum. It feeds fuel to a header tank that supplies the carburettor by gravity. Normal vacuum tap in header tank, vacuum from inlet manifold. The return from the header to the main tank is not restricted and fuel circulates freely. If the header tank is not full then a fuel supply problem must be suspected.

RUNNER 4 stroke. All have a pressurised fuel system.

Pump operates from inlet manifold vacuum.

Pump is attached to the bottom of the tank and supplies fuel directly to the carburettor via an inline fuel filter and a non return valve.

Note that the 180 also uses the vacuum line to supply vacuum to an over run valve on the carburettor.

TYPHOON 80 & 125. Do not have pressurised feed to the carburettor.

They have a second tank under the front panel to increase the capacity.

Fuel is pumped from the front (auxiliary) tank into the rear (main tank). The rear tank functions like all conventional gravity feed systems.

The system is not pressurised and fuel will circulate freely between front to rear tank until the front tank is empty and the rear tank is about half full.

If the pump / front tank system fails the only problem is that the scooter will have a reduced fuel capacity.

Refer to the separate explanation sheets for more detailed operation and fault finding information. (Typhoon 80-125 fuel system & Typhoon 80-125 fuel system fault finding)

X9. All models have a pressurised fuel system.

125. Leader Engine.

Pump is operated by inlet manifold vacuum. Fuel is supplied directly to the carburettor.

250. Honda engine.

Electrically operated pump that is controlled by the ECU. Fuel is supplied directly to the carburettor.

500. Electronic fuel injection.

See the workshop manual for an explanation.

HEXAGON EXS1T fuel system.

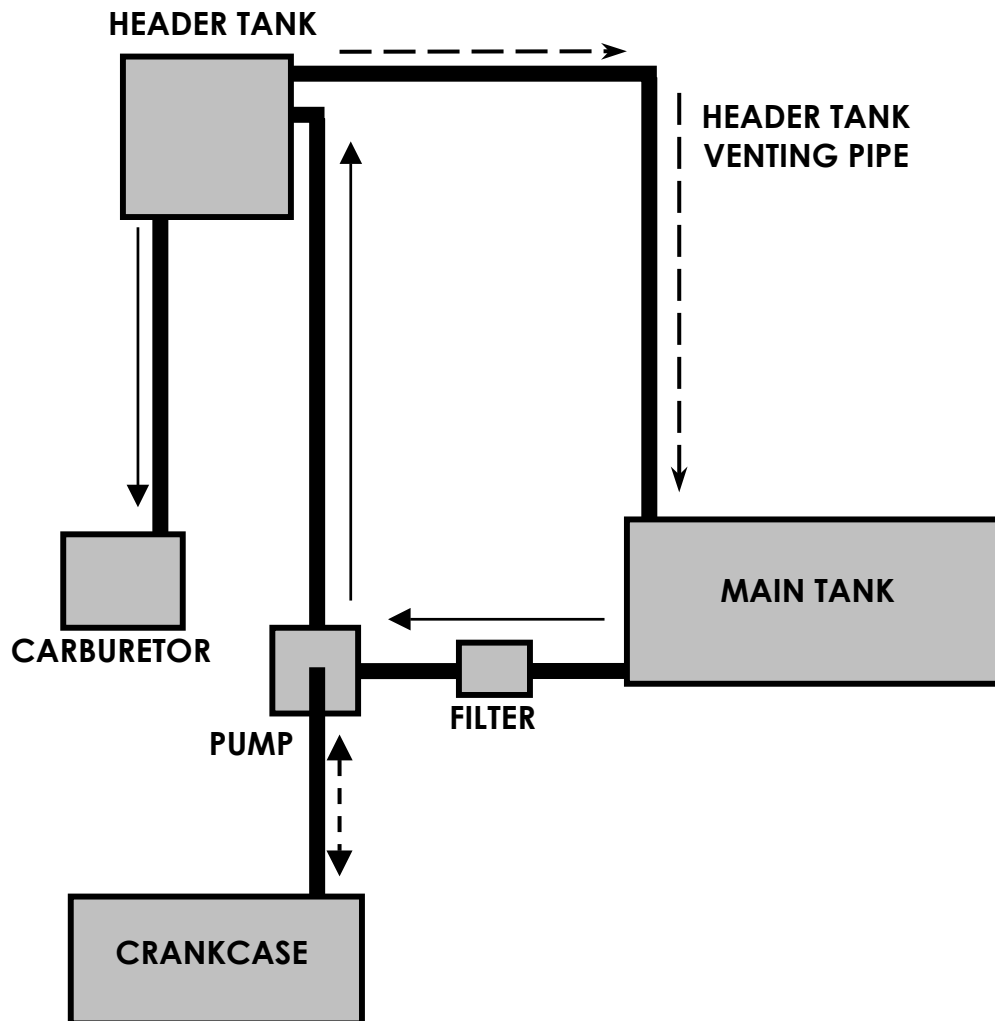

- All Hexagons have a pressurised fuel supply.
- The original EXS1T had a feed direct from the pump to the carburettor. Most EXS1T Hexagons have the system shown here.
- The return line from the header tank to the main tank is only there to allow the header tank to fill up. The connection in the header tank has a very small hole in it so air can escape but the system pressure will be maintained. It is very important that this hole is not enlarged.
- If system pressure is lost the scooter will still run but the mixture will now be very weak.
- The carburettor should be fitted with a float needle seat marked #1 to denote a 1mm hole. If a seat with a larger hole is used the float will not be able to shut off the fuel. The carburettor will flood and the engine will run rich.

DNA FUEL SYSTEM

Piaggio Ltd.

04/11/2002

PAGE 1 OF 2

125 / 180 NOTES:

1. No vacuum tap is fitted.
2. Fuel pipes are clear plastic. Vacuum pipes are black rubber.
3. Pump is driven by inlet manifold vacuum. not crankcase vacuum/pressure.
4. Supply to carburettor is pressurised.
5. DNA 125 is the same but without the over run valve.

Early DNA 125 / 180

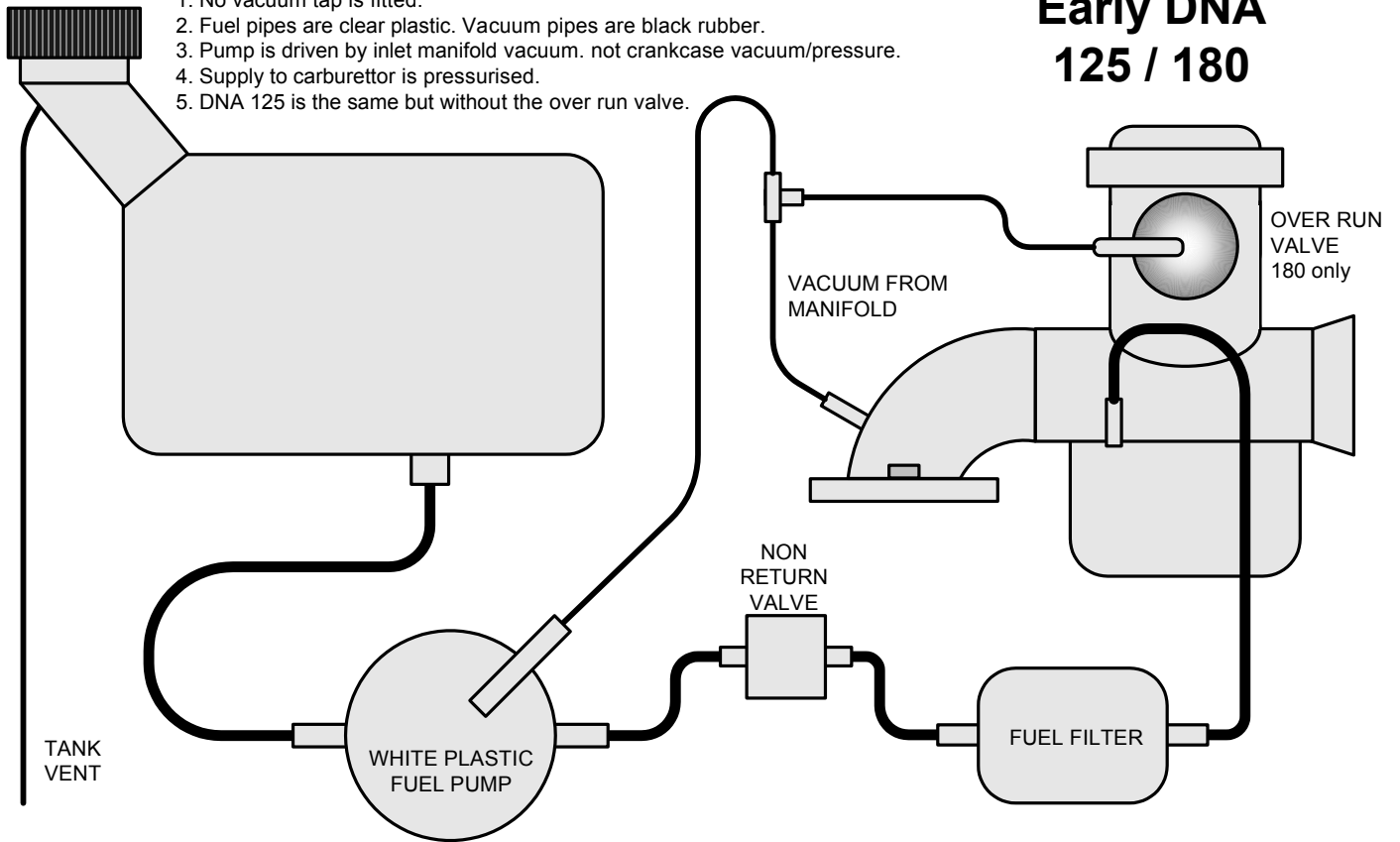

125 / 180 NOTES:

1. Vacuum tap is fitted to main tank.
2. Fuel pipes are clear plastic. Vacuum pipes are black rubber.
3. Pump is driven by inlet manifold vacuum. not crankcase vacuum/pressure.
4. Supply to carburettor is pressurised.
5. DNA 125 is the same but without the over run valve.
6. DNA 180 over run valve was deleted during early 2002

DNA 125 / 180 2001>

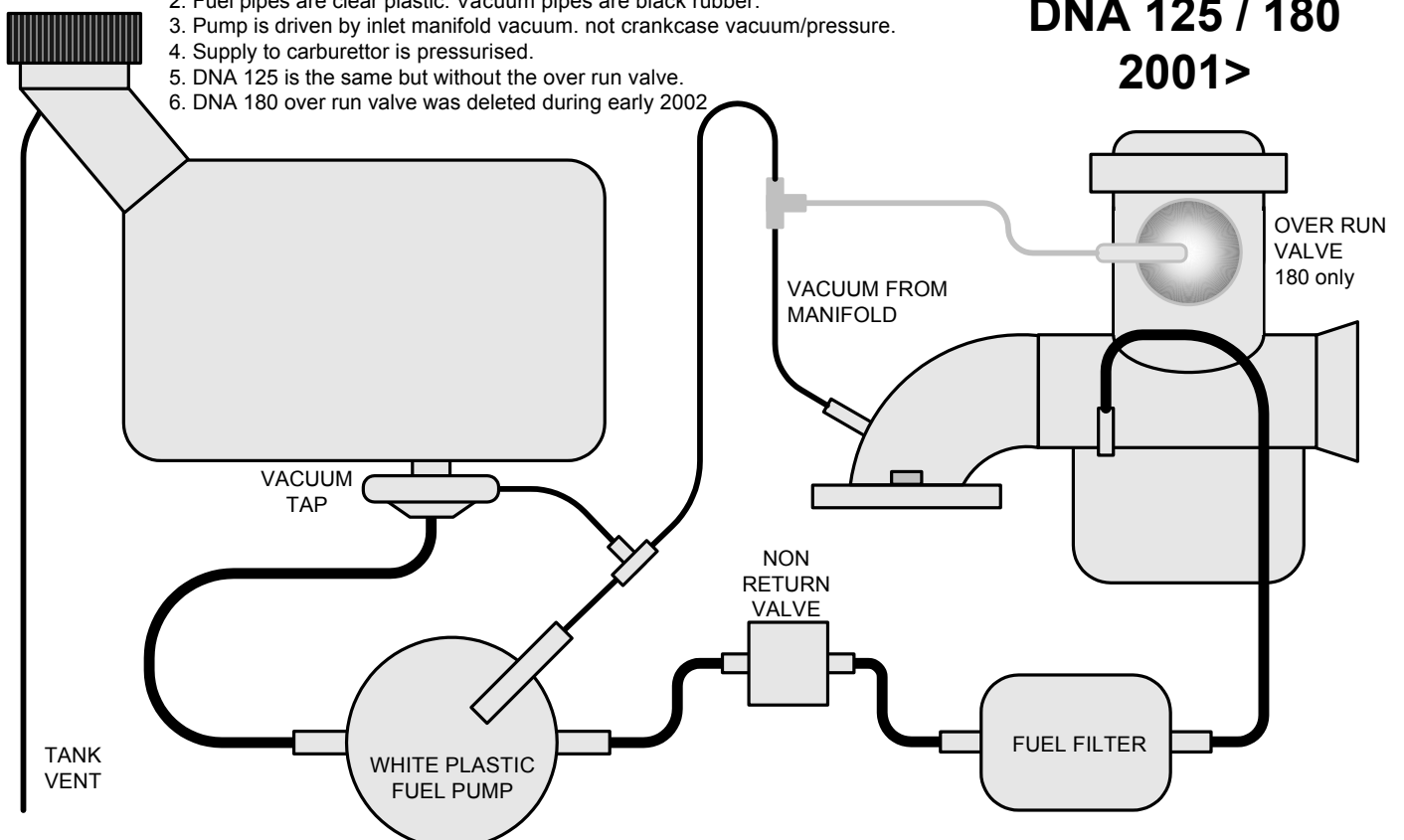

DNA FUEL SYSTEM

Piaggio Ltd.

04/11/2002

PAGE 2 OF 2

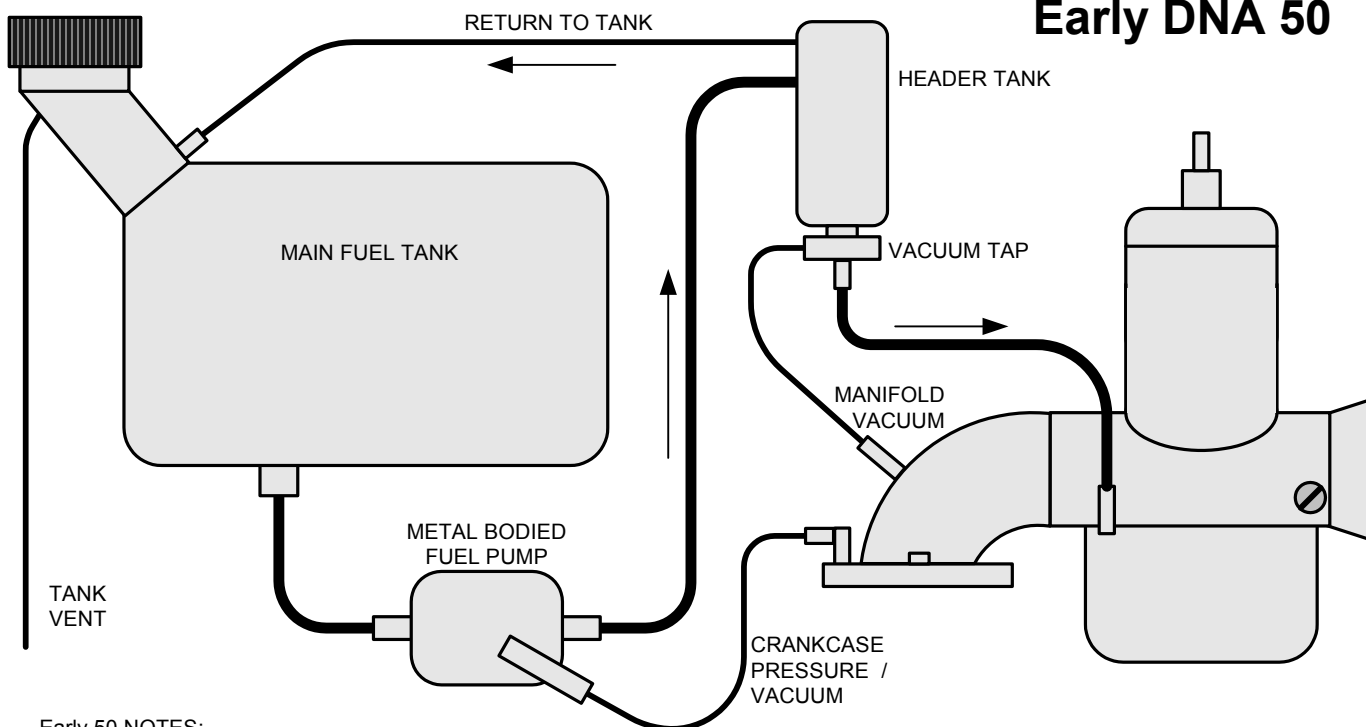

Early DNA 50

Early 50 NOTES:

1. Carburettor is gravity fed not pressure fed.
2. Fuel pipes are clear plastic. Vacuum pipes are black rubber.
3. Pump is driven by crankcase vacuum/pressure. Not manifold vacuum
4. Slow running adjustment is "air bleed". Turn in to richen

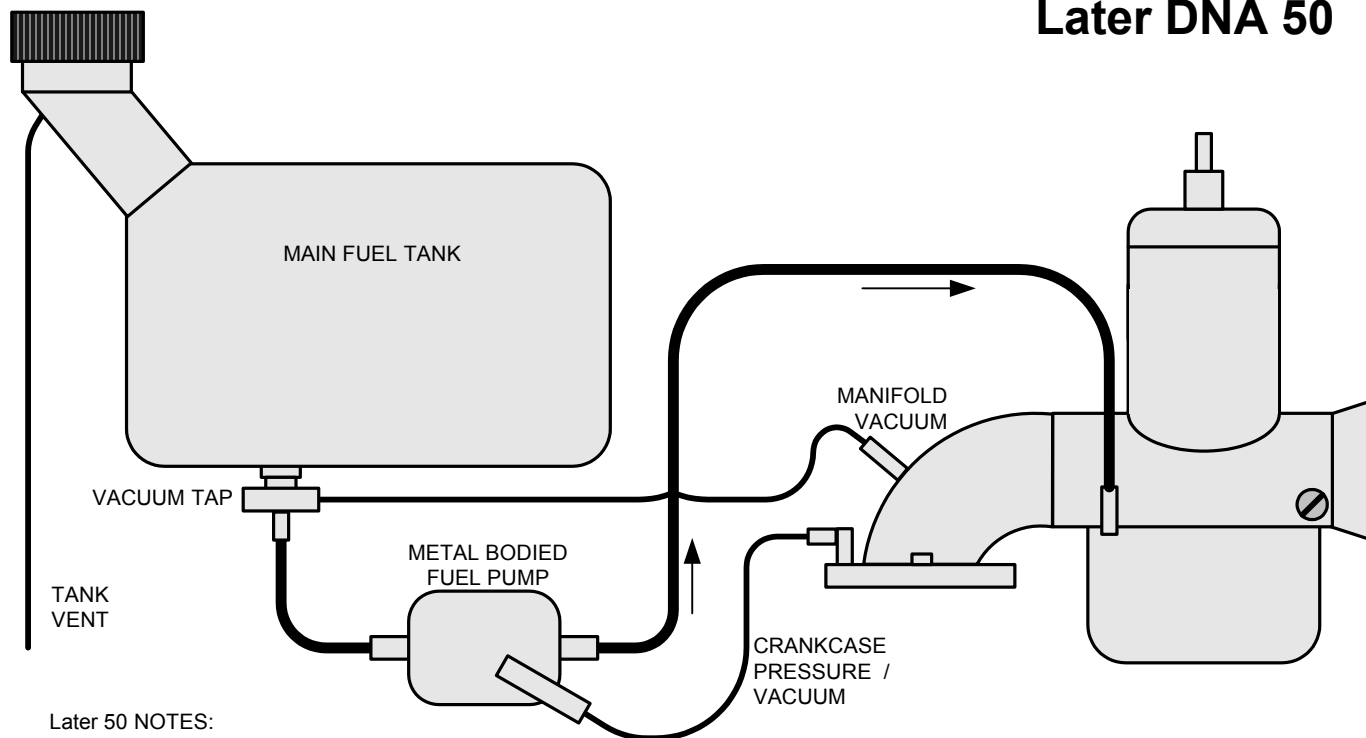

Later DNA 50

Later 50 NOTES:

1. Carburettor is pressure fed.
2. Fuel pipes are clear plastic. Vacuum pipes are black rubber.
3. Pump is driven by crankcase vacuum/pressure. Not manifold vacuum
4. Slow running adjustment is "air bleed". Turn in to richen

VESPA PX FUEL TAP

Piaggio Ltd.

07/08/2002

Piaggio Ltd.

Viewed from above. ie Sitting on the scooter

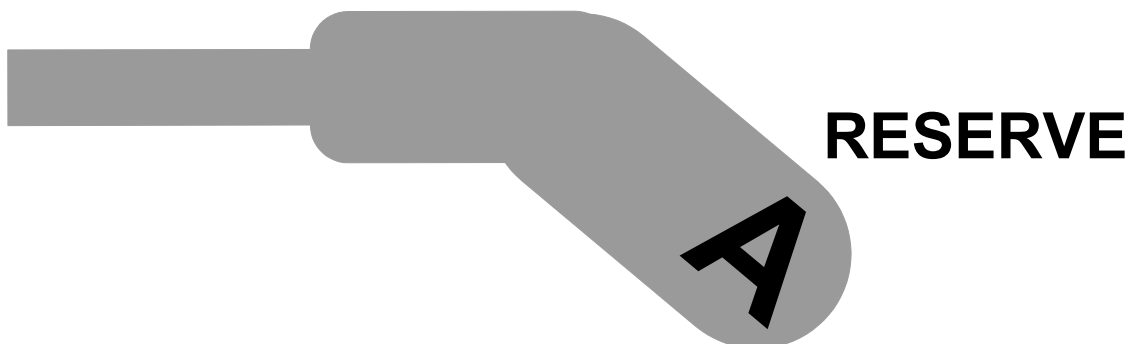
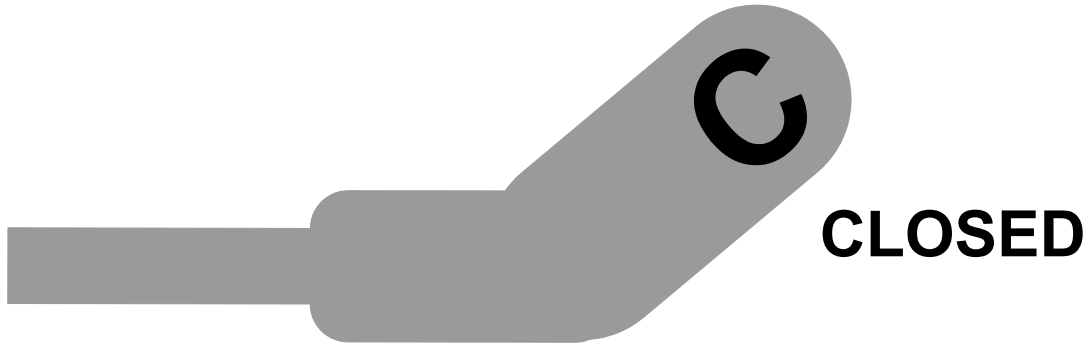

KEYS.

All Leader engined vehicles with immobilisers

Notes:

- ❑ Only the Service key should be used day to day. The Master key should be kept safely at home.
- ❑ Use the Service key for testing and fault finding. Only use the Master key for programming.
- ❑ It is not possible to programme a replacement master key to a previously programmed immobiliser.
- ❑ It is possible to programme new Service keys only if you have the original Master key.
- ❑ Original Service keys with a chip fitted can be recognised by this symbol etched into the metal near the top.



If new locks are fitted:

- ❑ Lock set will be supplied with one Master and one Service key.
- ❑ If you do not have any original keys then you must also change the CDI / Immobiliser unit.
- ❑ If you have the original Master key:
Use a screwdriver to prying the Master key apart so the Chip can be removed. Remove the chip from the new key and replace it with the original. Now the immobiliser will not know that anything has changed.
Now the system is working and you can programme the new Service keys.

Programming new Service keys:

Programming is easy but be aware that precise timing can be important.

- ❑ 1. Master key in and turn on for TWO seconds
- ❑ 2. Service key in and turn on for TWO seconds
- ❑ 3. If you have a second Service key : In and turn on for TWO seconds
- ❑ 4. Master key in and turn on for TWO seconds
- ❑ You have up to ten seconds to change keys over.
- ❑ If you are adding an extra Service key you must re-programme all the Service keys together, you can not just add a key.
- ❑ The system can remember up to seven keys at a time. If you programme an eighth key then the first one will be forgotten.

Obtaining spare keys from an automotive lock smith:

The system we use is also used by a lot of cars. Most automotive locksmiths will be able to supply spare Service keys. They can not supply new Master keys.

- ❑ Give the locksmith the Master or Service key.
- ❑ They should have a suitable blank to cut.
- ❑ They will scan the key to identify the chip type fitted.
- ❑ They fit the appropriate chip to the new key.
- ❑ This chip will be a clone of the original so, programming will not be necessary.

Keys Galore – London – 020 7586 9741
Express Keys – Kent – 01689 850008

First Access – Herts - 0115 967 6466
Auto Keys – London – 020 7586 9741

GILERA TYRES & WHEELS

2000 / 2001 / 2002 / 2003

MODEL	chassis prefix	FRONT				REAR			
		wheel	tyre	bar	wheel	tyre	bar		
Coguar 125 custom	ZAPM17	2.50 x 17	100 / 80 - 17, 52 S	T	1.8	3.00 x 17	130 / 70 - 17, 62 T	T	2.0-2.2
DNA 125 / 180	ZAPM26	3.50 x 14	120 / 70 - 14, 55 P	T/L	2.0	3.50 x 14	140 / 60 - 14, 64 P	T/L	2.2-2.5
DNA 50	ZAPC27	3.50 x 14	120 / 70 - 14, 55 L	T/L	1.8	3.50 x 14	140 / 70 - 14, 62	T/L	2.0
GSM 50 super motard	VTBC08	2.50 x 17	110 / 80 - 17, 52 T	T	1.4	3.50 x 17	130 / 70 - 17, 62 T	T	1.6
H@K 50 trail bike	VTBC08	1.40 x 21	80 / 90 - 21, 48 P	T	1.4	1.85 x 18	110 / 80 - 18, 58 P	T	1.6
Nexus 500 (due August 2003)	ZAPM35	3.50 x 15	120 / 70 - 15, 56 H	T/L	2.2	4.50 x 14	160 / 60 - 14, 65H	T/L	2.5
Ice 50	ZAPC30	3.00 x 10	120 / 90 - 10, 56 J	T/L	1.3	3.00 x 10	120 / 90 - 10, 56 J	T/L	1.8
RCR 50 trail bike	VTHSDR1EB		80 / 90 - 21	T	1.0-1.1		110 / 80 - 18		1.2-1.3
Runner 50 all versions	ZAPC14 / ZAPC362	3.50 x 12	120 / 70 - 12, 51L (or J)	T/L	1.6	3.50 x 12	130 / 70 - 12, 56L (or J)	T/L	1.8
Runner 50 Purejet	ZAPC361	3.50 x 12	120 / 70 - 12, 51L (or J)	T/L	1.6	3.50 x 12	130 / 70 - 12, 56L (or J)	T/L	1.8
Runner FX125 / FXR180 (rear drum)	ZAPM07 / ZAPM08	3.50 x 12	120 / 70 - 12, 51L (or J)	T/L	1.4	3.50 x 12	130 / 70 - 12, 56 L	T/L	1.6-2.2
Runner FX125 / FXR180 DD	ZAPM07 / ZAPM08	3.50 x 12	120 / 70 - 12, 51L (or J)	T/L	1.4	3.50 x 13	130/60-13, 60 P	T/L	1.6-2.2
Runner VX125 / VXR180	ZAPM24	3.50 x 12	120 / 70 - 12, 51 L	T/L	1.4	3.50 x 12	130 / 70 - 12, 56 L	T/L	1.6-2.2
Runner VXR200	ZAPM24	3.50 x 12	120 / 70 - 12, 51 P	T/L	1.4	3.50 x 12	130 / 70 - 12, 56 P	T/L	1.6-2.2
SMT 50 super motard	VTHSDR1FB		110 / 80 - 17	T	1.7-1.8		130 / 70 - 17		2.0-2.1
STALKER 50 (previously SKP)	ZAPC13 / ZAPC401	3.50 x 10	120 / 90 - 10, 56 J	T/L	1.2	3.50 x 10	130 / 90 - 10, 61 J	T/L	1.6-2.0
GFR 125 race replica	167	3.00 x 17	110 / 70 - 17, 54 T	T/L	1.8	4.00 x 17	150 / 60 - 17, 65 T	T/L	2.0-2.2
Nordwest 600 super motard	228	3.50 x 17	120 / 70 - 17, 60 R	T/L	2.1	4.50 x 17	160 / 60 - 17, 60 R	T/L	2.3-2.4
RC 600 trail	228	1.85 x 21	90 / 90 - 21, 54 T	T	1.8	2.50 x 17	130 / 80 - 17, 65 T	T	2.0-2.2
Saturno 350 & 500 café racer	222	3.00 x 17	110 / 70 - 17, 53 H	T/L	2.1	4.00 x 17	160 / 60 - 17, 68 H	T/L	2.3
XRT 350 / 600 trail	224 / 218	1.85 x 21	90 / 90 - 21, 54 T	T	1.8	2.50 x 17	130 / 80 - 17, 65 T	T	2.0-2.2
Chrono 125 race replica	164	2.50 x 16	100 / 80 ZR 16	T/L	1.8-2.0	3.00 x 17	130 / 70 ZR 17	T/L	2.0-2.2
Apache 125 trail		1.85 x 21	90 / 90 - 21, 54 R	T	1.8	2.50 x 18	120 / 80 - 18, 62 R	T	2.0-2.2
Freestyle 125 super motard		2.50 x 16	100 / 80 - 16, 50 S	T/L	1.8-1.9	3.00 x 17	130 / 70 - 17, 62 S	T/L	2.0-2.2
CX 125 race replica	158	3.50 x 17	120 x 60 ZR 17	T/L	2.1-2.2	4.00 x 17	150 / 60 ZR 17	T/L	2.3-2.4

Bold type denotes a current model. This list was last updated on 31 July 2003

Identify a vehicle by its chassis prefix AND model name.

PIAGGIO & VESPA TYRES & WHEELS

MODEL		FRONT				REAR			
	chassis prefix	wheel	tyre			wheel	tyre		
B 125 (Beverly 125)	ZAPM281	3.00 x 16	110 / 70 - 16, 52P	T/L	2.0	3.50 x 16	140 / 70 - 16, 65P	T/L	2.2 - 2.5
B 500 (Beverly 500) DUE MID 2003	ZAPM341	3.00 x 16	110 / 70 - 16, 52S	T/L	2.2	4.50 x 14	150 / 70 - 14, 66S	T/L	2.5
Diesis 100 (also Diesis 50)	ZAPM301 (ZAPC34)	3.00 x 12	120 / 70 - 12, 56J	T/L	1.7	3.00 x 12	120 / 70 - 12, 56J	T/L	1.9 - 2.1
Cosa 2 125 / 200	VNR2T / VSR2T	2.50 x 10	100 / 90 - 10	T	1.5	2.50 x 10	100 / 90 - 10.		1.75 - 2.0
Free 50	FCS1T & FCS2T	1.85 x 14	80 / 80 - 14, 43J	T/L	2.0	1.85 x 14	80 / 80 - 14, 43J	T/L	2.5-3.0
Hexagon 125	EXS1T	2.50 x 10	100 / 80 - 10, 58J	T/L	1.8	3.00 x 10	130 / 70 - 10, 62J	T/L	2.3-2.5
Hexagon GT 250, GTX 250	ZAPM14	3.00 x 11	120 / 70 - 11, 50L	T/L	1.8	3.00 x 11	130 / 70 - 11, 60L	T/L	2.2-2.5
Hexagon GTX 125	ZAPM20	3.00 x 11	120 / 70 - 11, 50L	T/L	1.8	3.50 x 11	130 / 70 - 11, 60L	T/L	2.0-2.5
Hexagon GTX 125	ZAPM20	3.50 x 12	120 / 70 - 12, 51L	T/L	1.8	3.50 x 12	140 / 60 - 12, 62L	T/L	2.0-2.5
Hexagon LX / LXT	ZAPM05 / ZAPM06	3.00 x 11	120 / 70 - 11, 50L	T/L	1.8	3.50 x 11	130 / 70 - 11, 60L	T/L	2.0-2.5
Liberty 125	ZAPM11 / ZAPM22	1.60 x 16	80 / 80 - 16, 46J	T/L	1.8	2.50 x 14	110 / 80 - 14, 56J	T/L	2.0-2.2
Liberty 50	ZAPC15 / ZAPC371	1.60 x 16	70 / 90 - 16, 42J 80 / 80 - 16, 46J ('98>)	T/L	1.8	2.15 x 11	90 / 80 - 16, 52J	T/L	2.0
NRG / NRG Mc ²	ZAPC04 / ZAPC18	3.50 x 13	130 / 60 - 13, 53J	T/L	1.3	3.50 x 13	130 / 60 - 13, 53J	T/L	1.8-20
NRG Extreme air / water cooled	ZAPC21 / ZAPC22	3.50 x 13	130 / 60 - 13, 53J	T/L	1.3	3.50 x 13	130 / 60 - 13, 53J	T/L	1.8-20
Quartz 50	NSP1T	2.50 x 10	100 / 80 - 10, 52J	T	1.2	2.50 x 10	100 / 80 - 10, 52J	T	1.7-2.5
Sfera 125 four stroke	ZAPM01	2.50 x 10	100 / 80 - 10, 52J	T/L	1.5	2.50 x 10	130 / 70 - 10, 62J	T/L	1.8-2.3
Sfera 50 / 80	NSL1T / NS81T	2.15 x 10	90 / 90 - 10, 50J	T/L		2.15 x 10	90 / 90 - 10, 52J	T/L	
Sfera RST 50 / 80	ZAPC01 / ZAPM03	2.50 x 10	100 / 80 - 10, 52J / 53J	T/L	1.5	2.50 x 10	110 / 80 - 10, 58J	T/L	1.8-2.3
Skipper 125	CSM1T	2.50 x 10	100 / 80 - 10, 52J	T	1.3	2.50 x 10	110 / 80 - 10, 58J	T	1.8-2.3
Skipper LX 125	ZAPM12	3.50 x 12	120 / 70 - 12, 51J	T/L	1.4	3.50 x 12	130 / 70 - 12, 56L	T/L	1.6-1.8
Skipper ST 125 four stroke	ZAPM21	3.50 x 12	120 / 70 - 12, 51L	T/L	1.4	3.50 x 12	130 / 70 - 12, 56L	T/L	1.6-1.8
Typhoon 125	ZAPM02	3.50 x 10	120 / 90 - 10, 56J	T/L	1.3	3.50 x 10	120 / 90 - 10, 56J	T/L	1.8-2.5
Typhoon 50 / Typhoon 50 RST	TEC1T / ZAPC19	3.50 x 10	120 / 90 - 10, 56J	T/L	1.3	3.50 x 10	120 / 90 - 10, 56J	T/L	1.8-2.5
Typhoon 80	TE81T	3.50 x 10	120 / 90 - 10, 56J	T/L	1.3	3.50 x 10	120 / 90 - 10, 56J	T/L	1.8-2.5
Velofax 50	VTAC02	1.60 x 17	70 / 90 - 17, 43M	T/L	2.0	1.85 x 16	80 / 90 - 16, 46M	T/L	2.5-3.0
Vespa ET2 50 two stroke	ZAPC16 / ZAPC381	2.50 x 10	100 / 80 - 10, 53L	T/L	1.3	3.00 x 10	120 / 70 - 10, 54L	T/L	1.8-2.0
Vespa ET4 50 four stroke	ZAPC26	2.50 x 10	100 / 80 - 10, 53L	T/L	1.3	3.00 x 10	120 / 70 - 10, 54L	T/L	1.8-2.0
Vespa ET4 125 four stroke	ZAPM04	2.50 x 10	100 / 80 - 10, 53L	T/L	1.3	2.50 x 10	130 / 70 - 10, 62L	T/L	1.8-2.0
Vespa ET4 Leader 125cc four stroke	ZAPM19	2.50 x 10	100 / 80 - 10, 53L	T/L	1.3	3.00 x 10	120 / 70 - 10, 54L	T/L	1.8-2.0
Vespa PX125	VNX2T or ZAPM093	2.10 x 10	3.50 - 10, 51J	T	1.25	2.10 x 10	3.50 - 10, 51J	T	1.75-2.3
Vespa PX200	VSX1T / ZAPM18	2.10 x 10	3.50 - 10, 59J	T	1.25	2.10 x 10	3.50 - 10, 59J	T	1.75-2.3
Vespa GT 125 / 200	ZAPM311 / 312	3.00 x 12	120 / 70 - 12, 51P	T/L	1.8	3.00 x 12	130 / 70 - 12, 62P	T/L	2.2
Vespa T5 Classic	VNX5T	2.10 x 10	3.50 - 10, 59J	T	1.25	2.10 x 10	3.50 - 10, 59J	T	1.75 - 2.3
X9 125	ZAPM23	3.50 x 14	120 / 70 - 14, 55 P	T/L	2.1	3.50 x 14	140 / 60 - 14, 64 P	T/L	2.3 - 2.5
X9 250	ZAPM23	3.50 x 14	120 / 70 - 14, 55 P	T/L	2.0	3.50 x 13	140 / 60 - 13, 63P	T/L	2.2 - 2.5
X9 500	ZAPM27	3.50 x 14	120 / 70 - 14, 55 S	T/L	2.2	3.50 x 14	140 / 70 - 14, 68 S	T/L	2.3 - 2.6
X9 500 fitted with dedicated top box					2.4				2.3 - 2.6
Zip 2000 Cat two stroke	ZAPC25	2.50 x 10	100 / 80 - 10, 53L	T/L	1.3	3.00 x 10	120 / 70 - 10, 54L	T/L	1.8 - 2.0
Zip 50 two stroke	SSL1T	2.15 x 10	90 / 90 - 10, 50J	T/L	1.2	2.15 x 10	90 / 90 - 10, 50J	T/L	1.7 - 2.5
Zip RST 50 two stroke	ZAPC06	2.50 x 10	100 / 80 - 10, 52J	T/L	1.4	2.50 x 10	100 / 80 - 10, 52J	T/L	1.8
Zip SP 50 two stroke	ZAPC11	2.50 x 10	100 / 80 - 10, 52J	T/L	1.4	2.50 x 10	110 / 80 - 10, 52J	T/L	1.8
Zip 125 four stroke	ZAPM25	2.50 x 10	100 / 80 - 10, 53L	T/L	1.6	3.00 x 10	120 / 70 - 10, 54L	T/L	2.0

Bold type denotes a current model. This list was last updated on 31 March 2003. Identify a vehicle by its chassis prefix AND model name.

Oil list

Make/Model		Engine			Gearbox			Final Drive			Forks		Coolant
Vespa ET2 50	2 str.	Synthetic 2 stroke API TC or higher	-	CVT	-			Gear	80W-90 light gear GL3 or higher	75cc	sealed unit	-	Air
Vespa ET4 50	4 str.	5W-40 synthetic API SJ or higher	850cc	CVT	-			Gear	80W-90 light gear GL3 or higher	80cc	sealed unit	-	Air
Vespa ET4 125	4 str.	20W-50 synthetic API SG or higher	850cc	CVT	-			Gear	80W-90 light gear GL3 or higher	90cc	sealed unit	-	Air
Vespa ET4 125 Leader	4 str.	5W-40 synthetic API SJ or higher	1 ltr.	CVT	-			Gear	80W-90 light gear GL3 or higher	100cc	sealed unit	-	Air
Vespa PX 125	2 str.	Synthetic 2 stroke API TC or higher	-	4 spd	80W GL4 or higher	250cc	n/a	-	-	-	sealed unit	-	Air
Vespa PX 200	2 str.	Synthetic 2 stroke API TC or higher	-	4 spd	80W GL4 or higher	250cc	n/a	-	-	-	sealed unit	-	Air
Piaggio B (Beverly) 125 / 200	4 str.	5W-40 synthetic API SJ or higher	1.1 ltr.	CVT	-			Gear	80W-90 light gear GL3 or higher	250cc	10W	102cc	Ethelyne Glycol Cuna NC 956-16
Piaggio Deisis 100	2 str.	Hi Scooter 2 Tech	-	CVT	-			Gear	80W-90 light gear GL3 or higher	110cc	sealed unit	-	Air
Piaggio Hexagon 125	2 str.	Synthetic 2 stroke API TC or higher	-	CVT	-			Gear	80W-90 light gear GL3 or higher	85cc	sealed unit	-	Ethelyne Glycol Cuna NC 956-16
Piaggio Hexagon LX125 / LXT180	2 str.	Synthetic 2 stroke API TC or higher	-	CVT	-			Gear	80W-90 light gear GL3 or higher	80cc	sealed unit	-	Ethelyne Glycol Cuna NC 956-16
Piaggio Hexagon GT 250	4 str.	20W-50 synthetic API SG or higher	800cc	CVT	-			Gear	80W-90 light gear GL3 or higher	150cc	sealed unit	-	Ethelyne Glycol Cuna NC 956-16
Piaggio Hexagon GTX 125 / 180 (11")	4 str.	5W-40 synthetic API SJ or higher	1 ltr.	CVT	-			Gear	80W-90 light gear GL3 or higher	150cc	sealed unit	-	Ethelyne Glycol Cuna NC 956-16
Piaggio Hexagon GTX 125 / 180 (12")	4 str.	5W-40 synthetic API SJ or higher	1 ltr.	CVT	-			Gear	80W-90 light gear GL3 or higher	150cc	10W	102cc	Ethelyne Glycol Cuna NC 956-16
Piaggio Liberty 50	2 str.	Synthetic 2 stroke API TC or higher	-	CVT	-			Gear	80W-90 light gear GL3 or higher	100cc	20W	30cc	Air
Piaggio Liberty 125	4 str.	20W-50 synthetic API SG or higher	850cc	CVT	-			Gear	80W-90 light gear GL3 or higher	95cc	20W	90cc	Air
Piaggio Liberty 125 Leader	4 str.	5W-40 synthetic API SJ or higher	1 ltr.	CVT	-			Gear	80W-90 light gear GL3 or higher	200cc	20W	90cc	Air
Piaggio NRG 50 water cooled models	2 str.	Synthetic 2 stroke API TC or higher	-	CVT	-			Gear	80W-90 light gear GL3 or higher	85cc	sealed unit	-	Ethelyne Glycol Cuna NC 956-16
Piaggio NRG 50 air cooled models	2 str.	Synthetic 2 stroke API TC or higher	-	CVT	-			Gear	80W-90 light gear GL3 or higher	85cc	sealed unit	-	Air
Piaggio Sfera 50	2 str.	Synthetic 2 stroke API TC or higher	-	CVT	-			Gear	80W-90 light gear GL3 or higher	85cc	sealed unit	-	Air
Piaggio Sfera 125	4 str.	20W-50 synthetic API SG or higher	850cc	CVT	-			Gear	80W-90 light gear GL3 or higher	90cc	sealed unit	-	Air
Piaggio Skipper 125	2 str.	Synthetic 2 stroke API TC or higher	-	CVT	-			Gear	80W-90 light gear GL3 or higher	80cc	sealed unit	-	Air
Piaggio Skipper ST 125	4 str.	5W-40 synthetic API SJ or higher	1 ltr.	CVT	-			Gear	80W-90 light gear GL3 or higher	150cc	sealed unit	-	Air
Piaggio Typhoon 50	2 str.	Synthetic 2 stroke API TC or higher	-	CVT	-			Gear	80W-90 light gear GL3 or higher	85cc	sealed unit	-	Air
Piaggio Typhoon 125	2 str.	Synthetic 2 stroke API TC or higher	-	CVT	-			Gear	80W-90 light gear GL3 or higher	100cc	sealed unit	-	Air
Piaggio X9 125	4 str.	5W-40 synthetic API SJ or higher	1 ltr.	CVT	-			Gear	80W-90 light gear GL3 or higher	150cc	20W	90cc	Ethelyne Glycol Cuna NC 956-16
Piaggio X9 250	4 str.	20W-50 synthetic API SG or higher	1.1-1.3	CVT	-			Gear	80W-90 light gear GL3 or higher	200cc	20W	90cc	Ethelyne Glycol Cuna NC 956-16
Piaggio X9 500	4 str.	5W-40 synthetic API SJ or higher	1.7 ltr.	CVT	-			Gear	80W-90 light gear GL3 or higher	250cc	20W	90cc	Ethelyne Glycol Cuna NC 956-16
Piaggio Zip 50	2 str.	Synthetic 2 stroke API TC or higher	-	CVT	-			Gear	80W-90 light gear GL3 or higher	75cc	20W	25cc	Air
Piaggio Zip 50 4t	4 str.	5W-40 synthetic API SJ or higher	850cc	CVT	-			Gear	80W-90 light gear GL3 or higher	80cc	20W	25cc	Air
Piaggio Zip 125 (single sided fork)	4 str.	5W-40 synthetic API SJ or higher	1 ltr.	CVT	-			Gear	80W-90 light gear GL3 or higher	100cc	sealed unit	-	Air
Piaggio Zip 125 (telescopic fork)	4 str.	5W-40 synthetic API SJ or higher	1 ltr.	CVT	-			Gear	80W-90 light gear GL3 or higher	100cc	20W	60cc	Air
Gilera DNA 50	2 str.	Synthetic 2 stroke API TC or higher	-	CVT	-			Gear	80W-90 light gear GL3 or higher	100cc	20W	280cc	Ethelyne Glycol Cuna NC 956-16
Gilera DNA 125 / 180	4 str.	5W-40 synthetic API SJ or higher	1 ltr.	CVT	-			Gear	80W-90 light gear GL3 or higher	150cc	20W	280cc	Ethelyne Glycol Cuna NC 956-16
Gilera GSM / H@K 50	2 str.	Synthetic 2 stroke API TC or higher	-	6 spd.	80W GL4 or higher	500cc		Chain	-	?	?		Ethelyne Glycol Cuna NC 956-16
Gilera Coguar 125	4 str.	20W-50 synthetic API SG or higher	1.2 ltr.	5 spd.	integral with engine	-		Chain	-	10W	280cc		Air
Gilera Ice 50 (front fork marked "TH")	2 str.	Synthetic 2 stroke API TC or higher	-	CVT	-			Gear	80W-90 light gear GL3 or higher	75cc	10W	72cc	Air
Gilera Ice 50	2 str.	Synthetic 2 stroke API TC or higher	-	CVT	-			Gear	80W-90 light gear GL3 or higher	75cc	10W	90cc	Air
Gilera Runner 50	2 str.	Synthetic 2 stroke API TC or higher	-	CVT	-			Gear	80W-90 light gear GL3 or higher	75cc	sealed unit	-	Ethelyne Glycol Cuna NC 956-16
Gilera Runner FX125 / FXR180 (early)	2 str.	Synthetic 2 stroke API TC or higher	-	CVT	-			Gear	80W-90 light gear GL3 or higher	80cc	sealed unit	-	Ethelyne Glycol Cuna NC 956-16
Gilera Runner FX125 / FXR180 (late)	2 str.	Synthetic 2 stroke API TC or higher	-	CVT	-			Gear	80W-90 light gear GL3 or higher	80cc	20W	80cc	Ethelyne Glycol Cuna NC 956-16
Gilera Runner VX125 / VXR180	4 str.	5W-40 synthetic API SJ or higher	1 ltr.	CVT	-			Gear	80W-90 light gear GL3 or higher	150cc	20W	80cc	Ethelyne Glycol Cuna NC 956-16
Gilera SKP (Stalker) 50	2 str.	Synthetic 2 stroke API TC or higher	-	CVT	-			Gear	80W-90 light gear GL3 or higher	75cc	sealed unit	-	Air
Gilera GFR 125	2 str.	Synthetic 2 stroke API TC or higher	-	6 spd.	80W GL4 or higher	1.3 ltr.		Chain	-	10W	400cc		Ethelyne Glycol Cuna NC 956-16
Gilera Saturno 350 / 500	4 str.	15W-40 synthetic	2.2 ltr.	5 spd.	integral with engine	-		Chain	-	><7.5W	310cc		Ethelyne Glycol Cuna NC 956-16
Gilera Nordwest 600	4 str.	15W-40 synthetic	2.2 ltr.	5 spd.	integral with engine	-		Chain	-	10W	400cc		Ethelyne Glycol Cuna NC 956-16
Gilera RC 600	4 str.	15W-40 synthetic	2.2 ltr.	5 spd.	integral with engine	-		Chain	-	10W	640cc		Ethelyne Glycol Cuna NC 956-16

SPARK PLUGS

PIAGGIO / VESPA	mm	NGK	Champion
B 125 (Beverly) 125 (& 200) four stroke	0.7-0.8	CR8 EB	RG4 HC
B 500 (Beverly) 500 four stroke	0.7-0.8	CR7 EKB	RG6 YC
Cosa 125 , 150	0.6	B9 ES (BR9 ES)	N2C (RN2C)
Cosa 200	0.6	B7 ES (BR7 ES)	N4C (RN4C)
Free 50 (all versions)	0.5-0.6	BR9 ES	RN2C
Hexagon 125 &180 two stroke (all versions)	0.5-0.6	BR9 ES	RN2C
Hexagon GT250 & GTX 250 (Honda 4 stroke)	0.8-0.9	DPR6 EA9	
Hexagon GTX 125 four stroke	0.7-0.8	CR9 EB	RG4 HC
Liberty 50 two stroke (all versions)	0.5-0.6	BR9 ES	RN2C
Liberty 125 four stroke (original version)	0.7-0.8	CR9 E	RG4 HC
Liberty 125 Leader four stroke	0.7-0.8	CR7 EB	RG6 YC
Liberty 125 Leader four stroke (heavy use)	0.7-0.8	CR8 EB	RG4 HC
NRG 50 water cooled (heavy use)	0.5-0.6	BR10 ES	RN1C
NRG 50 (air or water cooled. All versions)	0.5-0.6	BR9 ES	RN2C
Quartz 50	0.5-0.6	BR9 ES	RN2C
Sfera 125 four stroke	0.5-0.6	CR9 E	RG4 HC
Sfera 50 & Sfera 80 (all versions)	0.5-0.6	BR9 ES	RN2C
Skipper ST 125 four stroke (all versions)	0.7-0.8	CR9 E	RG4 HC
Skipper 125 two stroke (all versions)	0.6-0.7	BR9 ES	RN2C
Velofax 50 two stroke	0.5-0.6	BR9 ES	RN2C
Vespa 50 Special & PK50S	0.6	B6 HS	L86
Vespa ET2 50 two stroke (carburettor)	0.5-0.6	BR9 ES	RN2C
Vespa ET4 50 four stroke	0.7-0.8	CR9 E	RG4 HC. RG4 PHP
Vespa ET4 125 four stroke (all versions)	0.7-0.8	CR9 E	RG4 HC
Vespa GT 125	0.7-0.8	CR8 EB	RG4 HC
Vespa GT 200	0.7-0.8	CR7 EB	RG6 YC
Vespa Primavera ET3	0.6	B7 HS	
Vespa Primavera & PK 125	0.6	B6 HS	
Vespa PX 125	0.5-0.6	B7 HS	L82C
Vespa PX 200	0.5-0.6	B7 ES (BR7 ES)	N4C (RN4C)
Vespa T5 Classic 125	0.6	B9ES (BR9 ES)	N2C (RN2C)
X9 125 (Piaggio 4 stroke engine)	0.7-0.8	CR8 EB	RG4 HC
X9 250 (Honda 4 stroke engine)	0.8-0.9	DPR7 EA9	
X9 500 (Piaggio 4 stroke engine)	0.7-0.8	CR7 EKB	RG6 YC
Zip 50 four stroke	0.7-0.8	CR9 E	RG4 HC. RG4 PHP
Zip 50 2 stroke (all versions, inc. catalytic)	0.6-0.7	BR9 ES	RN2C
Zip 125 four stroke	0.7-0.8	CR7 EB	RG6 YC
GILERA			
Coguar 125 (Honda 4 stroke engine)	0.8-0.9	DPR8 EA9	
DNA 125 & DNA 180 four stroke	0.7-0.8	CR8 EB	
DNA 50 two stroke (catalytic)	0.6-0.7	BR9 ES	RN2C
H@K & GSM 50 2 stroke (Gilera engine)	0.5-0.6	BR9 ES	RN2C
H@K & GSM 50 2 stroke (Derbi engine)	0.-0.		
ICE 50 two stroke catalytic	0.6-0.7	BR9 ES	RN2C
Nexus 500 four stroke			
Runner VX125 & VXR180 four stroke	0.7-0.8	CR8 EB	
Runner 50, 125 & 180 two stroke (all versions)	0.6-0.7	BR9 ES	RN2C
Runner 50 "Purejet" direct injection 2 stroke	0.6-0.7		RG6 YCA
SKP 50 two stroke	0.5-0.6	BR9 ES	RN2C
OLDER GILERA MOTORCYCLES			
Saturno 350 / 500 four stroke	0.6-0.7	DPR8 EA9	A5YC
Dakota 350 / 500 four stroke	0.6-0.7	DPR8 EA9	A5YC
Nordwest 600 four stroke	0.6-0.7	DPR9 EA9	
RC 600 four stroke	0.6-0.7	DPR8 EA9	
CX 125 & Apache & Crono & Free-Style 2 st	0.6-0.7	B10 EG - BR9 EG	N82 - C55
GFR 125 two stroke	0.6-0.7	B10 EGV	C55C

Up side down Forks

Piaggio Ltd.

07/08/2002

Typhoon / Runner etc.

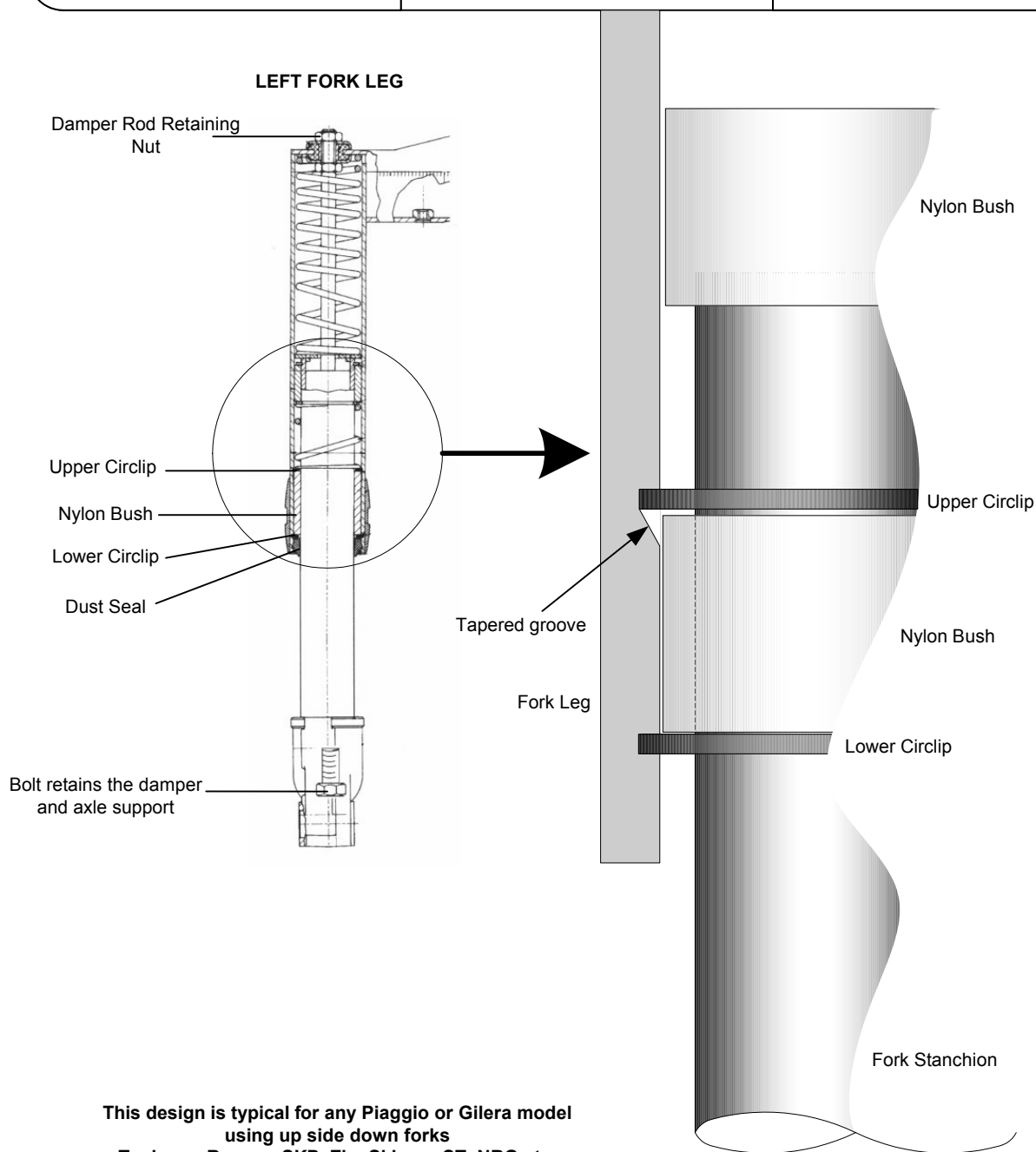

Forks are grease filled for lubrication. The grease can be expected to work past the nylon bush so the chrome stanchion will get a dirty ring round it.

Damping is by a sealed hydraulic damper cartridge in the left leg. The cartridge is held at the bottom by a bolt that will be found in the bottom of the axle mounting. The top of the damper rod is held by a nut on top of the top yoke. If the seals in this unit fail you will find oil dripping from the bottom of the left leg.

Some 50's did not have the damper. To check if a damper is fitted: look for the nut on top of the left leg, no nut means no damper.

To separate the fork leg:

1. Remove damper top nut (from left leg only).
2. Remove the dust seal.
3. Remove the bottom circlip.

4. Pulling the stanchion hard will force the upper circlip out of the tapered groove, the circlip and bush will be pulled out.

On very early forks the top circlip groove was not tapered so it will be necessary to pull the bush out to get to the circlip.

To pull the bush out:

1. Lubricate the bush with WD40 or similar.
2. Carefully screw two small self tapping screws into the nylon bush and pull it out using two pairs of pliers.

Note that there are several manufactures of these forks and although they look the same the internal components may not be interchangeable between makes.

PISTONS AND SMALL END BEARINGS

Small End Bearing sizes.

Small end needle roller bearings fitted to two stroke twist and go engines and PX engines are supplied in four sizes they are colour coded for identification. The end of the con rod will either be colour coded or it will be marked with a series of lines.

Bearing colour	Con rod marking
Copper	I
Blue	II
White	III
Green	IIII

Parts catalogues will show four part numbers the lowest number will be the first in this list.

Service Station manuals specify the con rod small end diameters so you can determine the correct bearing size by measurement.

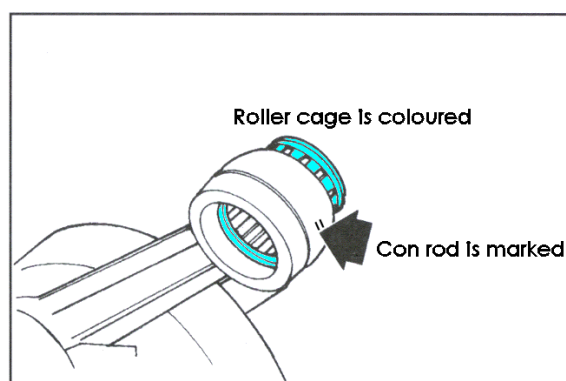

Piston sizes.

Piaggio use alloy or cast iron barrels on different engines. Alloy barrels can not be re-bored and over size pistons are not available. Oversize pistons are available for cast iron barrels. These are listed as 1M, 2M, 3M.

In addition to oversize there will be four pistons listed for all engines as "FC" or FC1, FC2 etc. These are tolerance fittings.

Pistons can be matched to barrels in two ways. Either by referring to the tolerance data page near the front of the appropriate Service Station Manual or by referring to the marking on the crown of the piston and the top of the barrel. On some engines barrel and piston will both have a letter stamped into them. Both letters should match. The lowest (first) part number will be the smallest piston and first in this list.

Piston marking	Size
E	FC 1
F	FC 2
G	FC 3
H	FC 4

Remember, if you are measuring barrel and piston you should always measure in line with the gudgeon pin because they will have worn oval. Most wear occurs at right angles to the gudgeon pin.

PX 200 / 125 "COSA" TYPE CLUTCH

The COSA type clutch is now fitted to the PX 200 & PX125.

It can replace the old type clutch as a complete assembly. p/n 433548 (200cc) p/n 288650 (125cc)

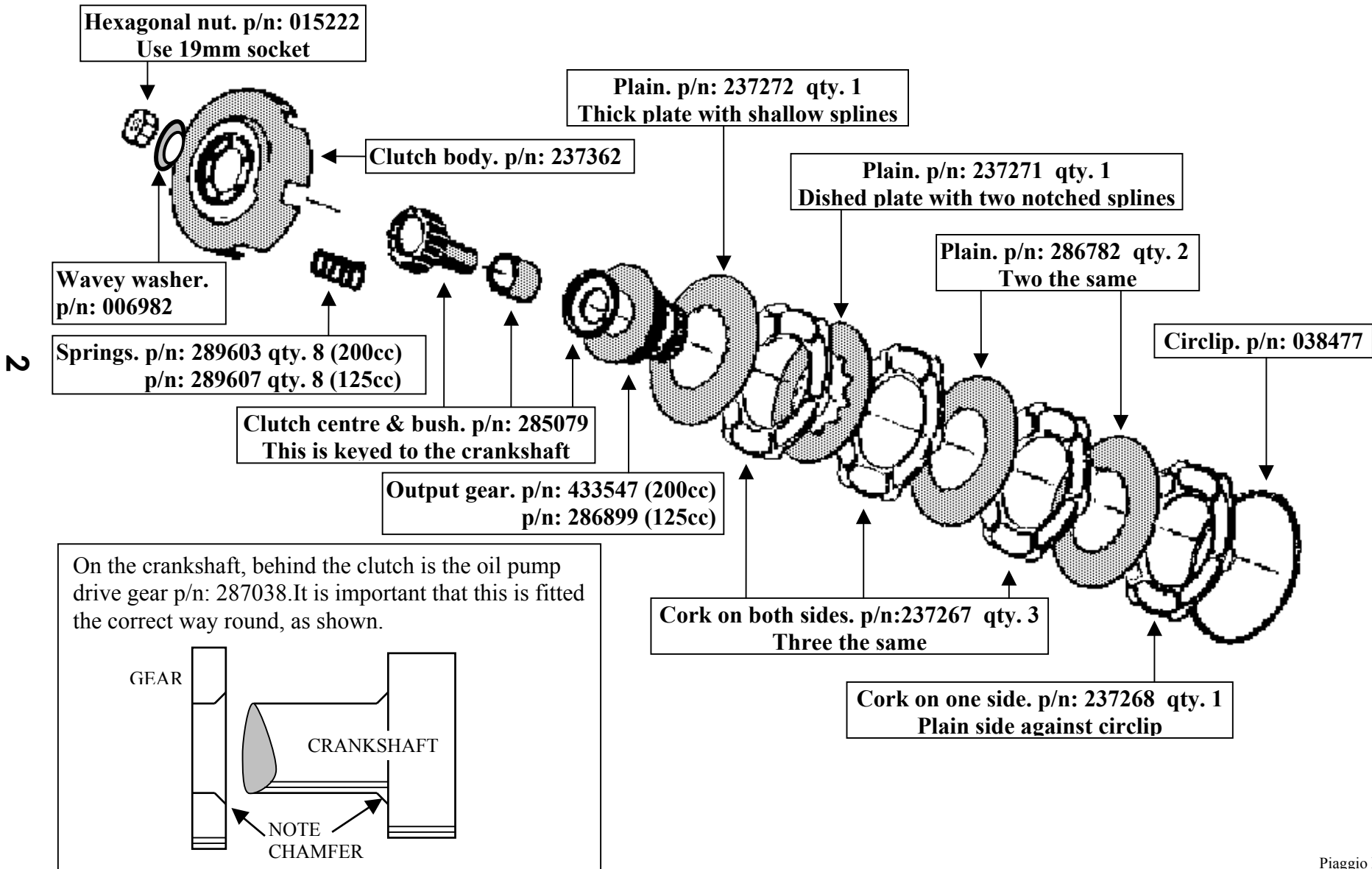

FITTING NEW MAIN BEARINGS TO TWO STROKE AUTO'S

Replacing the main bearings is not a difficult job but it **MUST** be done the correct way to ensure a correct fit.

The problem can be that you do not achieve the correct end float in the crank so the bearings are being side loaded. This will cause a bearing failure within a very short time (200 miles max!)

It is **vital** that the end float is checked with a dial gauge once the cases have been bolted together.

The following assembly procedure is the **ONLY** way to do the job. It is the quickest and easiest. Also it almost guarantees correct tolerance. Please do it this way:

1. Heat the bearings in engine oil. First signs of smoke from the oil is hot enough!
About 100 degrees
2. Support the crankshaft vertically. Drop one bearing onto crank. If it will not drop on (by gravity) it is not hot enough. If you have to tap it home, **ONLY** use a piece of tube to act on the centre race. **NEVER** hit the outer race. Once it is on leave it to cool.

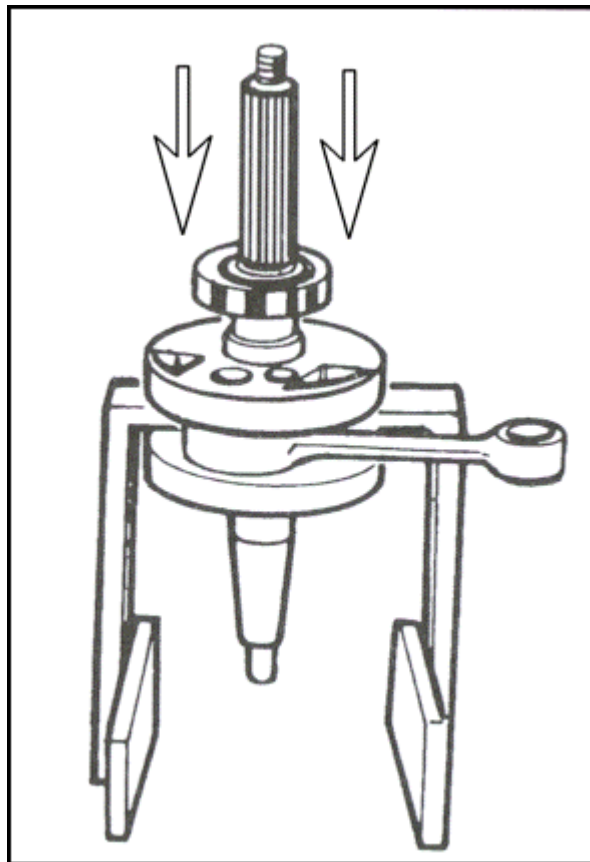

3. Turn crank over and drop other bearing on. Leave it to cool completely.
4. Position the drive side crankcase half on its side with inside facing up. Support it on blocks of wood so the crank can be dropped in (again, just using gravity).

5. Heat the case with a hot air gun, mostly heat it around the area where the bearing will fit. Don't try to hurry this. It is hot enough when the rear end of the case is too hot to keep your hand on.
6. When it is hot enough then drop the crank / bearing in and leave it to cool. If it will not drop in easily then the case is not hot enough yet.
7. Once it is completely cold turn the case over so the crank is hanging down and then fit the crank removal tool 20163Y (50cc) or 20262Y (125 & 180cc) as if you were going to press the crank back out of the case.
8. Tighten the extractor bolt as tight as you can by hand. This will push the crank out against the bearing so all the free play in the bearing has been removed and the crank is pushed out as far as it can go. Do not use a spanner to tighten the bolt or you may move the bearing. Tightening it by hand can not move the bearing (you ain't that strong).

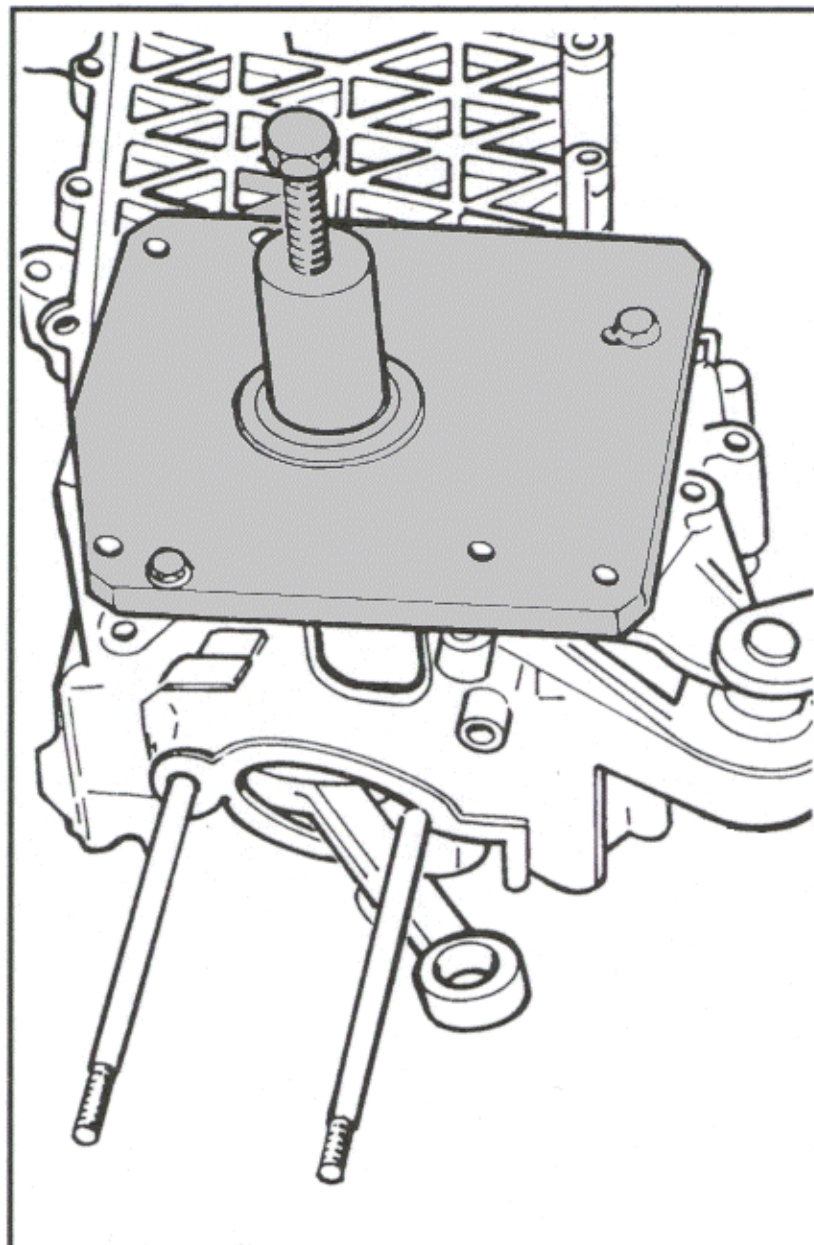

9. Now position the other crank case half on the blocks of wood (inside facing up) heat it as before and drop the crank / crank case onto it.
10. Fit the cases together with liquid gasket (not silicon). Don't forget the water pump impeller on water cooled engines. Bolt it up and leave it to cool.
11. Once it is completely cold remove the special tool. Now use a dial gauge to measure the end float. Pull the crank one way, notice the gauge reading and then push it the other way. You MUST have 0.03 - 0.09mm free play.
12. If you have nearly got the free play try hitting each end of the crank with a nylon hammer and check again.
13. If you have not got enough free play there is no point carrying on. Take it apart and do it again (I would recommend using new bearings just in case the others have been damaged!).

The reason for establishing the end float is to ensure that there is no side load on the bearings. Ball races do not like side load and they will fail very quickly. Checking the free play guarantees that the bearing is not side loaded and the balls can run centrally in the bearing tracks.

The benefits of this method include:

- ❑ We only heat each part once. No wasted time re-heating
- ❑ We only used gravity to fit it together. No risk of damage and it must be together properly.
- ❑ The bearings have only been heated in oil. No risk of damage.

Please do not try and improvise. Make sure you have all the correct tools for the job. They are a very good investment for time saved and stress avoided.

If you have any questions please give your Regional After Sales Manager a call.



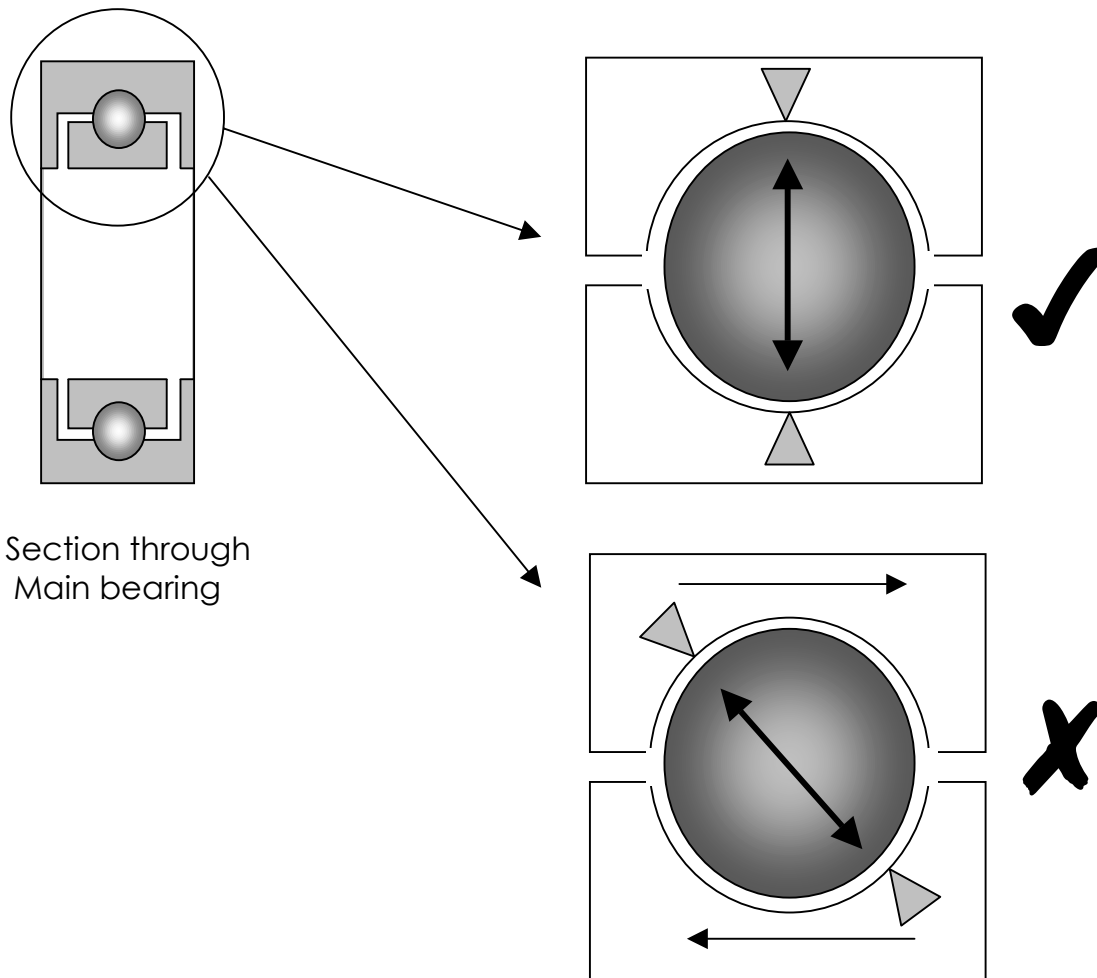

Section through
Main bearing

Why do ball races fail if they are subjected to a side load?

1. The top diagram shows a bearing correctly fitted with no side load. Only the whole load is being transmitted through the balls.
2. The lower diagram shows a bearing that has a side load. The inner and outer tracks are being pushed in opposite directions. The balls are now transmitting the load at an angle and the side force has the effect of forcing the balls up a ramp (the shape of the track). The balls are trying to push the inner and outer tracks apart. Because of the ramp effect the force applied is far higher than just the side loading. So now the tracks are being subjected to not only the normal load but also another huge load. In addition the extra load may force the lubrication away from the point of contact so you will have a dry metal to metal contact rather than a film of oil separating the parts.

FITTING NEW MAIN BEARINGS TO TWO STROKE AUTO'S

The problem can be that you do not achieve the correct end float in the crank so the bearings are being side loaded. This will cause a bearing failure within a very short time (200 miles max!)

It is **vital** that the end float is checked with a dial gauge once the cases have been bolted together.

This procedure should ensure correct assembly, please do it this way:

1. Heat the bearings in engine oil. First signs of smoke from the oil is hot enough!
2. Drop one bearing onto crank. If it will not drop on (by gravity) it is not hot enough. Once it is on leave it to cool.
3. Turn crank over and drop other bearing on. Leave it to cool completely.
4. Position drive side crank case half on its side with inside facing up. Support it on blocks of wood so the crank can be dropped in (again, just using gravity).
5. Heat the case with a hot air gun, mostly heat it around the area where the bearing will fit. Don't try to hurry this. It is hot enough when the rear end of the case is too hot to keep your hand on.
6. When it is hot enough then drop the crank / bearing in and leave it to cool.
7. Once it is completely cold fit the crank removal tool 20163Y (50cc) or 20262Y (125 & 180cc) as if you were going to press the crank back out of the case.
8. Tighten the extractor bolt as tight as you can by hand. This will push the crank out against the bearing so all the free play in the bearing has been removed and the crank is pushed out as far as it can go. Do not use a spanner to tighten the bolt or you may move the bearing. Tightening it by hand can not move the bearing (you ain't that strong).
9. Now position the other crank case half on the blocks of wood (inside facing up) heat it as before and drop the crank / crank case onto it.
10. Fit the cases together with liquid gasket (not silicon). Don't forget the water pump impeller. Bolt it up and leave it to cool.
11. Once it is completely cold remove the special tool. Now use a dial gauge to measure the end float. Pull the crank one way, notice the gauge reading and then push it the other way. You **MUST** have 0.03 - 0.09mm free play.
12. If you have nearly got the free play try hitting each end of the crank with a nylon hammer and check again.
13. If you have not got enough free play there is no point carrying on. Take it apart and do it again (using new bearings!).

The reason for doing this is to ensure that there is no side load on the bearings. Ball races do not like side load and they will fail very quickly.

Checking the free play guarantees that the bearing is not side loaded and the balls can run centrally in the bearing tracks.

If you have any questions please give your After Sales Representative a call.

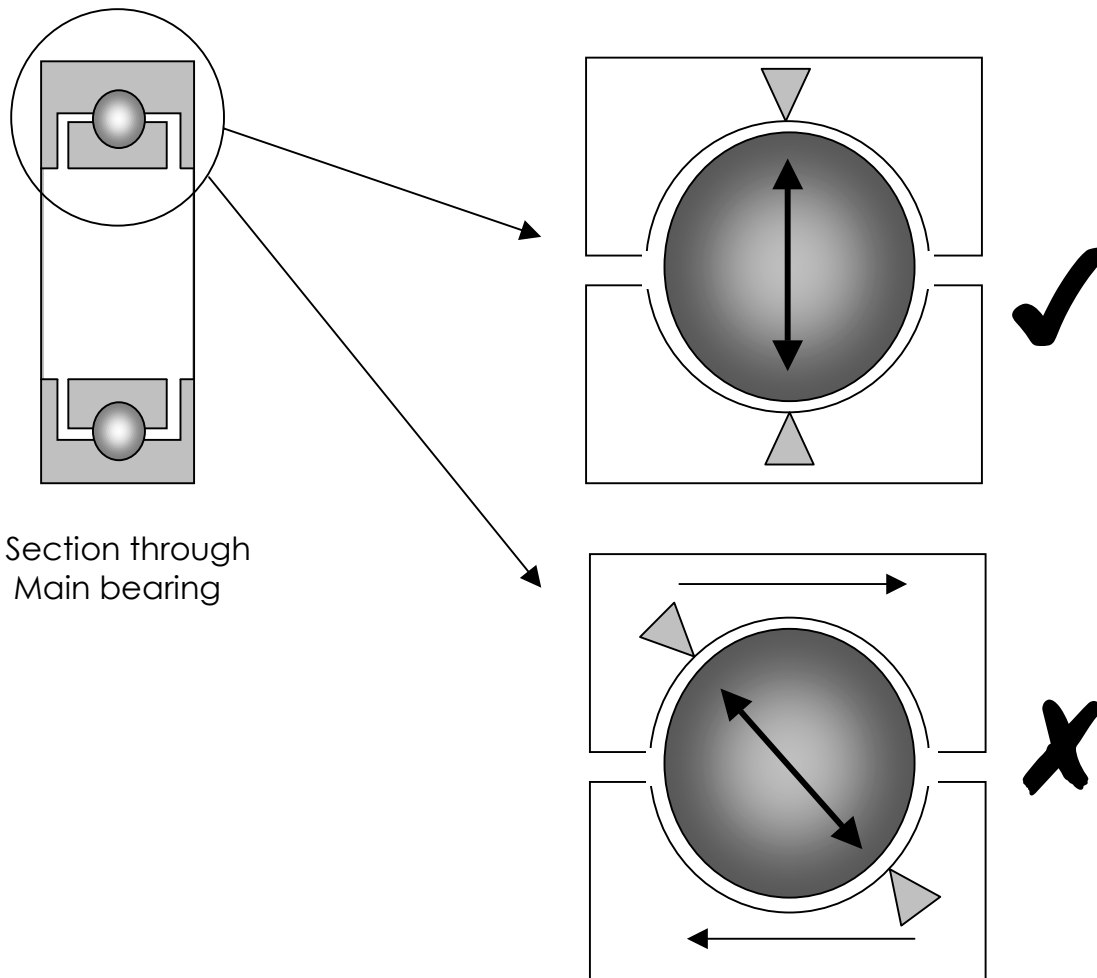

Section through
Main bearing

Why do ball races fail if they are subjected to a side load?

1. The top diagram shows a bearing correctly fitted with no side load. Only the whole load is being transmitted through the balls.
2. The lower diagram shows a bearing that has a side load. The inner and outer tracks are being pushed in opposite directions. The balls are now transmitting the load at an angle and the side force has the effect of forcing the balls up a ramp (the shape of the track). The balls are trying to push the inner and outer tracks apart. Because of the ramp effect the force applied is far higher than just the side loading. So now the tracks are being subjected to not only the normal load but also another huge load. In addition the extra load may force the lubrication away from the point of contact so you will have a dry metal to metal contact rather than a film of oil separating the parts.

SERVICE LIMITS				
		NEW	LIMIT	Or change at:
50cc 2T				
(Inc. Purejet)	Belt	-	17.5mm	15,000 km
	Rollers	-	18.5mm	-
	Oil Pump Belt	-	-	20,000 km
50cc 4T				
	Oil	850cc		6000 km
	Belt	-	17.5mm	12,000 km
	Rollers	18.9mm	18.5mm	-
125cc 2T				
	Belt	-	21.0mm	12,000 km
	Rollers	-	18.5mm	-
	Oil Pump Belt	-	-	30,000 km
125cc 4T orig.				
	Oil	850cc		5000 km
	Belt		17.2mm	10,000 km
	Rollers		18.5mm	-
125cc 4T Leader.				
	Oil	1 ltr.		6000 km
	Belt	22.5mm	21.5mm	12000 km
	Rollers	19.0mm	18.5mm	-
B 125	Brake Disks	4.00mm	3.50mm	-
180cc 2T				
	Belt	-	20.5mm	12,000 km
	Rollers	-	19.5mm	-
	Oil Pump Belt	-	-	30,000 km
180cc 4T Leader.				
	Oil	1 ltr.		6000 km
	Belt	20.5mm	19.5mm	12000 km
	Rollers	20.6mm	20.0mm	-
250cc 4T Hex				
	Oil	800cc		3000 km
	Belt		21mm	18000 km
	Rollers	23.8mm	23.2mm	-
250cc 4T X9				
	Oil	1 ltr.		3000 km
	Belt	23.3	22.3	18000 km
	Rollers	>< 23mm	22.5mm	-
500cc X9				
	Oil	1.7 ltr.		6000 km
	Belt	26.2mm	25mm	12000 km
	Rollers	24.9mm	24.5mm	Check 12000 km
	Front Disk	4.00mm	3.50mm	-
	Rear Disk	5.00mm	4.50mm	-

QUICK REFERENCE GUIDE

FIRST SERVICE is always at 1000 km (625 miles)

Older engines used variator rollers that needed greasing. Later greasless rollers can be fitted to early variators. If greased rollers are used lubricate sparingly at every service (except first): Use only "Jota" grease p.n. 494643

125 4t. (Original) air cooled

Check oil level by sight glass.

Engine Oil: 10w40 synthetic. 850 cc.

Oil Change: 3000 km

Service: 6000 km.

Rear Hub: 80w Light Gear. 90 cc.

Fuel: Min 95. Unleaded.

Tappets: 0.15 mm.

Ign. Timing: 10° @ 1500. 32° @ 6000 rpm.

Idle: 1600 – 1800 rpm

Slow running: 3.5 turns out. (out to richen)

CO: 3.5% (hose on exhaust outlet)

Spark Plug: 0.7 - 0.8 mm
Champion RG4HC
NGK CR8E (colder)

Rollers wear limit: 18.5 mm min. dia.

Belt wear limit: 17.2mm (min width)

Change Belt: 10,000 km (24 mths)

125/180 4t LEADER 2v & 4v

Check oil level with dipstick screwed IN

Engine Oil: 1 ltr 5w40 synthetic SJ

Oil change: 6000 km (check @ 3000 km)

Service: 6000 km (12mths)

Rear Hub: 80/90 light gear oil. Quantity varies, check manual

Coolant: 50 / 50 mix
Check manual for quantity.

Tappets: in: 0.10mm. ex: 0.15 mm

Ign. Timing: 10° @ 2000. 34° > 4500 (125)

10° @ 2000. 30° > 4000 (180)
35° > 7000 (180)

Idle: > <1600 rpm.

Slow running: 3 turns out (out to richen)

CO: 3.1- 4.5% (40x500mm
long tube on exhaust)

Spark Plug: 0.8 - 0.9mm
Check manual for correct plug

Rollers wear limit: 18.5 mm min.dia. 125
20.0 mm min.dia. 180

Belt wear limit: 21.5 mm width 125

19.5 mm width 180

Belt Change: 12,000 km or 24 mths

GT 250 / GTX 250 (Honda Helix)

Check oil level with dipstick screwed OUT

Engine Oil: 800cc (1ltr after strip) 10w40

Oil change: 3000 km

Service: 6000 km

Rear Hub: 150cc 10w40

Coolant: 1.82 ltr.
50/50 with distilled water

Tappets: Back off one division

Ign. Timing: 12° @ 1500. 27° @ 7000 rpm

Idle: 1500 rpm.

Slow running: 2 ¾ turns out (out to richen)

CO: not quoted

Spark Plug: 0.8 - 0.9mm
NGK DPR6EA9

Pulley wear limit: 0.4mm

Belt wear limit: 21mm (min width)

Belt Change: 12,000 km (24 mths)

X9 250 (Honda Foresight engine)

Check oil level with dipstick screwed OUT

Engine Oil: 1.1ltr (1.3 at strip) 20w50

Oil change: 3000km

Service: 6000km

Rear Hub: 160cc (200cc at strip)
80/90 light gear oil

Coolant: 1.2 lt 50 / 50 mix

Tappets: 0.12mm = 1 division inwards

Ign. Timing: 1500 = "F" mark

Idle: 1500 rpm

Slow running: 2 1/8 turns out
(out to richen)

Fuel Level: 18.5mm ± 1mm

CO: not quoted
Spark Plug: 0.8 - 0.9mm
NGK; DPR7 EA9.

Rollers wear limit: 22.5 mm min.dia.

Belt wear limit: 22.3 mm min. width

Belt Change: 18,000km. 36 mths

125 / 180 2t Water cooled.

Service: 5000 km (12 mths)
Hub Oil: 80cc - 80w90 light gear oil
Spark Plug: 0.6 - 0.7 mm
Champion RN2C
NGK BR9 ES
Belt Change: width = 20.5mm min - 180
width = 21mm min - 125
12,000 km (24 mths)
Oil pump belt: 20,000 km (36 mths)

125 2t Air cooled.

Service: 5000 km (12 mths)
Hub Oil: 80w90 light gear oil
Typhoon = 100cc
Skipper = 80cc
Spark Plug: 0.6 - 0.7 mm
Champion RN2C
NGK BR9 ES
Belt change: 12,000 km (24mths)
Oil pump belt: 20,000 km

50 2t Air cooled.

Service: 5000 km (12mths)
Hub Oil: 75cc - 80w90 light gear oil
NRG = 85cc
Liberty = 100cc
Spark Plug: 0.5 - 0.6 mm
Champion RN2C
NGK BR9 ES
Belt width: 17.5 mm min width
Belt change: 15,000 km (36mths)
Oil pump belt: 20,000 km

50 2t Water cooled.

Service: 5000 km (12mths)
Hub Oil: 80w90 light gear oil
Runner = 75cc
DNA = 100cc
NRG = 85cc
Spark Plug: 0.5 - 0.6 mm
Champion RN2C
NGK BR9 ES
Belt width: 17.5 mm min width
Belt change: 15,000 km (36mths)
Oil pump belt: 20,000 km

50 2t Velofax.

Service: 4000 km (12mths)
Hub Oil: fill to level (48cc?)
80w90 light gear oil
Spark Plug: 0.5 - 0.6 mm
Champion RN2C
NGK BR9 ES
Belt width: not quoted
Roller dia: not quoted
Oil pump belt: 20,000 km (36 mths)

50 4t Air cooled.

Check oil level by sight glass.
Engine Oil: 850cc. 5w40 synthetic SJ
Oil change: 6000 km (check 3000 km)
Service: 6000 km
Rear Hub: 80cc. 80/90 light gear oil.
Tappets: in: 0.10mm. ex: 0.15 mm
Ign. Timing: 8° @ 1500. 24° > 5000
Idle: 1900-2000 rpm.
Slow running: 3 turns out (out to richen)
CO: 3.2% ± 0.5 (40-50 mm
long tube on exhaust)
Spark Plug: 0.8 - 0.9mm
NGK CR 9EB
Champion RG 4HC
Rollers wear limit: 18.5 mm min.dia.
Belt wear limit: 17.5 mm width
Belt Change: 12,000 km or 24 mths

Vespa PX 125 / 200.

Service: 5000 km (12 mths)
Gear box oil: 250cc - 80w light gear oil
or 10w40 4 stroke engine oil
Spark Plug: 0.5 - 0.6mm
PX200 - Champion N4C
NGK B7 ES
PX125 - Champion L82C
NGK B7 HS
Ignition timing:
Between "A" & "IT" marks when new
Set to "IT" 18° btdc

125 4t Coguar. Honda XL125 engine

Check oil level with dipstick screwed out.

Engine Oil: 1.2 ltr. 20w50 synthetic SG

Oil change: 3000 km

Service: 6000 km

Tappets: in:0.10 mm. ex: 0.10 mm

Ign. Timing: 15° @ 1400. 32° @ 3450

Idle: 1400 rpm.

Slow running: 2 turns out (out to richen)

CO: 5% ± 0.5%

Spark Plug: 0.8 - 0.9 mm

NGK DPR8 EA9

Chain size:

50 2t H@K, GSM. Gilera engine

Service: 5000 km (12 mths)

Gearbox Oil: 500cc - 10w40 4t engine oil

Spark Plug: 0.5 - 0.6 mm

Champion RN2C

NGK BR9 ES

Chain size: 415 x 124 links

50 2t PUREJET. Direct injection

Service: 5000 km (12mths)

Hub Oil: 75cc - 80w90 light gear oil

Spark Plug: 0.5 - 0.6 mm

Champion RG6 YCA

NGK ?

Belt width: 17.5 mm min width

Belt change: 15,000 km (36mths)

Rollers: 18.5 mm min.dia.

Fuel Filter: 10,000 km (24 mths)

Mixer belt: 20,000 km

100 2t. Diesis. Derbi engine

Service: 5000 km (12 mths)

Hub Oil: 110cc - 80w90 light gear oil

Spark Plug: 0.6 - 0.7 mm

Champion RN2C

NGK BR9 ES

Belt change: min width = 16mm

5000 km (12 mths)

Then every 10,000 km

500 4t Master

Check oil level with dipstick screwed IN

Engine Oil: 1.7 ltr 5w40 synthetic SJ

Oil change: 6000 km (check @ 3000 km)

Service: 6000 km (12mths)

Rear Hub: 250cc 80/90 light gear oil.

Coolant: 1.8 ltr. 50 / 50 mix

Tappets: in: 0.15mm. ex: 0.15 mm

Idle: 1450 rpm. ± 50 rpm.

CO: 1.25% ± 0.25%

CO²: 14.5% ± 1%

Spark Plug: 0.7 - 0.8mm

Champion: RG6YC

NGK: CR7 EKB

Rollers wear limit: 24.5 mm min.dia.

Belt wear limit: 25 mm width.

Belt Change: 12,000 km or 24 mth.

Air Filter Change: 18,000 km or 36 mth.

Fuel Filter Change: 48,000 km

- ❑ If there is ever any doubt about service intervals for a vehicle, always use the intervals shown in the owners handbook.
- ❑ Piaggio recommend fully synthetic oil for all engine applications.
- ❑ Piaggio have never offered any tuning parts for any vehicles and we will never recommend tuning or de-restricting a vehicle for any reason.
- ❑ All 50cc vehicles are only available as “mopeds” restricted to 30mph.
- ❑ All current 125cc vehicles are “Learner Legal” producing less than 15 hp (11kw). They are not restricted If they are tuned they will not be learner legal and warranty will be affected.

PIAGGIO / VESPA / GILERA CHASSIS NUMBER LOCATION.

Traditional Vespa. PX125/200. T5 Classic. Etc.

- ❑ Lift the seat. Remove engine cover (off side) by turning the off side lever near the seat hinge, outwards. Chassis number is stamped into the chassis near the rear.

Vespa ET4, ET2.

- ❑ Lift seat. Lift out helmet storage compartment. Chassis number is stamped into the frame across the scooter just in front of the battery.

Hexagon 125, 180 & 250.

- ❑ Remove seat by unscrewing the knob in the boot. Chassis number is stamped into the frame toward the rear.

NRG, Skipper, Sfera, Typhoon, Zip. Gilera Runner & SKP.

- ❑ Chassis number is stamped into a plate on the off side below the foot boards. You do not need to remove anything, just look under the scooter.

Ice 50

- ❑ Remove the black central cover over the oil tank filler. The Chassis number is stamped into the main chassis tube on the off side just below the oil filler cap.

Liberty, Free

- ❑ Chassis number is stamped onto a plate attached to the frame on the off side above the cooling fan cover.

Velofax

- ❑ Chassis number is stamped into the underside of the rear carrier (part of the frame).

X9 125, 180, 250 & 500. B (Beverly) 125, 200 & 500

- ❑ Lift seat. Pull up the internal carpet at the rear. Remove the small panel in the floor toward the rear. Chassis number is directly below.

DNA, H@K, GSM and older Gilera motorcycles, Nordwest, RC600, GFR etc.

- ❑ The chassis number is stamped into the right hand side (off side) of the head stock.

A duplicate of the chassis number will not be found in any other location. If the number has been removed it will not be possible to identify the vehicle. Most vehicles now have a specification sticker, which is most likely to be under the seat. Along with the Homologation and specification details you should find the chassis number. This metallic sticker is often removed or lost.

Restriction Notes

Never discuss the technicalities of how to de-restrict with end users. But, advice given can prevent problems caused by them fiddling blindly.

- ❑ Piaggio have never supplied any information about how vehicles are restricted or how to make them go faster.
- ❑ Piaggio can not advocate de-restriction for any reason.
- ❑ Vehicles will only have been homologated as Mopeds so will be technically illegal if they are de-restricted.
- ❑ Piaggio have never offered any tuning parts.
- ❑ If a 50 is de-restricted the licensing requirements will be the same as a 125, so Piaggio's official line is "Do not de-restrict, if you want to go faster get a 125"

125cc engines are not restricted, they are designed to produce no more than 11 kw. So they will be learner legal.

50cc engines are always restricted and are only sold as 50 km/h mopeds. There is no "full power" option. Most countries in Europe have the same 50 km/h category.

Restriction of 50cc 2 stroke twist and go engines.

Non catalysed engines.

All engines will have:

- ❑ A spacer between the front pulley halves. (stops it obtaining the highest top gear ratio)
- ❑ A branch pipe on the exhaust. (stops the engine revving beyond a certain point)

In addition, **water cooled** engines will have:

Older engines, starting with the first Runner and NRG MC2.

- ❑ Have a tube spot welded into the inlet end of the silencer.

Newer engines.

- ❑ Have a tube seam welded into the out let end of the exhaust pipe.

All these restrictions can be removed without the need to re-jet the carburettor.

Catalysed engines.

- ❑ Have the spacer and the branch pipe. These engines will need a larger main jet, two sizes up on standard. Piaggio are probably unable to supply these.
- ❑ Do not remove the baffle plate from the carburettor bell mouth.
- ❑ Do not do anything to the "secondary air pipe" going to the exhaust.

Restriction of 50cc 4 stroke twist and go engines. See Chapter 3 page 11

All engines:

- ❑ A spacer between the front pulley halves.
- ❑ An electrical restriction in the CDI unit.
- ❑ They will need a larger main jet if de-restricted. Fowlers can supply this.

Restriction of 50cc 2 stroke geared engines. H@K & GSM. See Chapter 4 page 2

- ❑ Only restriction is a restrictor in the inlet end of the exhaust pipe.
- ❑ A two size larger main jet will be needed. A standard DellOrto part.

If de-restriction is carried out by an authorised dealer, Piaggio are happy that the warranty will not be affected. Any tuning or fitting of after market parts by the end user or the dealer will affect the warranty.

50cc Moped restriction information

What is a moped?

A Moped is a two wheel vehicle of no more than 50cc with a design top speed of 30 mph (on the flat).

All current Piaggio, Vespa and Gilera 50cc two-wheel vehicles are restricted and are only supplied as Moped's. They are only tested and homologated as mopeds.

Piaggio do not recommend de-restricting or modifying for any reason.

If the vehicle may be used on a public road. The person carrying out the modification must take full responsibility for the possible implications of their actions.

If a Moped is de-restricted.

1. It becomes a 50cc Motorcycle.

DVLA should be informed and the vehicle re-registered.

2. It may not conform to motorcycle requirements and may not be legal.

For example; Lighting requirements are different for Mopeds and Motorcycles.

Piaggio can not give any assurance that a de-restricted vehicle will be technically legal.

3. A motorcycle licence will be required.

A 50cc motorcycle has the same licence requirement as a 125cc.

A Motorcycle can not be ridden on a provisional motorcycle licence before basic training is completed (CBT).

A full car licence allows a moped to be ridden but not a 50cc motorcycle.

4. A rider must be at least 17 years old.

A 16 year old can ride a Moped but not a 50cc Motorcycle.

5. The Insurance company who are insuring the vehicle should be informed.

The premium will probably be un-affected but any modification should be notified to the insurer in writing. Insurance will be invalid if the vehicle is modified and the insurer not informed.

Remember that if the vehicle or the rider is not legal then the insurance will be invalid.

6. Piaggio Ltd. Are happy that the warranty will remain valid if the de-restriction is carried out by an authorised dealer.

If any "tuning" or fitting of non Piaggio parts is carried out then the warranty will be invalid.

Piaggio's advice has to be: If you want to go faster, get a 125.

Recently a 16 year old was stopped for speeding, when the Police realised his age they immediately charged him with.

1. Exceeding the speed limit.
2. Riding a motorcycle with no motorcycle licence (he was under age).
3. Riding a motorcycle without valid insurance.

The dealer who did the de-restriction was charged and found guilty of aiding and abetting!

The boy's father attempted to sue the dealer!

A disclaimer may be of little use as a defence. Be warned! If someone rides to your shop and asks you to de-restrict then rides away they will be breaking the law and they have only been able to break the law because you helped them.

If you get a disclaimer signed one of the conditions should be "I do not intend to use this vehicle on public roads" and another should be "I am fully aware of the legal implications of having my vehicle de-restricted and I am prepared to take full responsibility for this".

ALARM CONNECTION

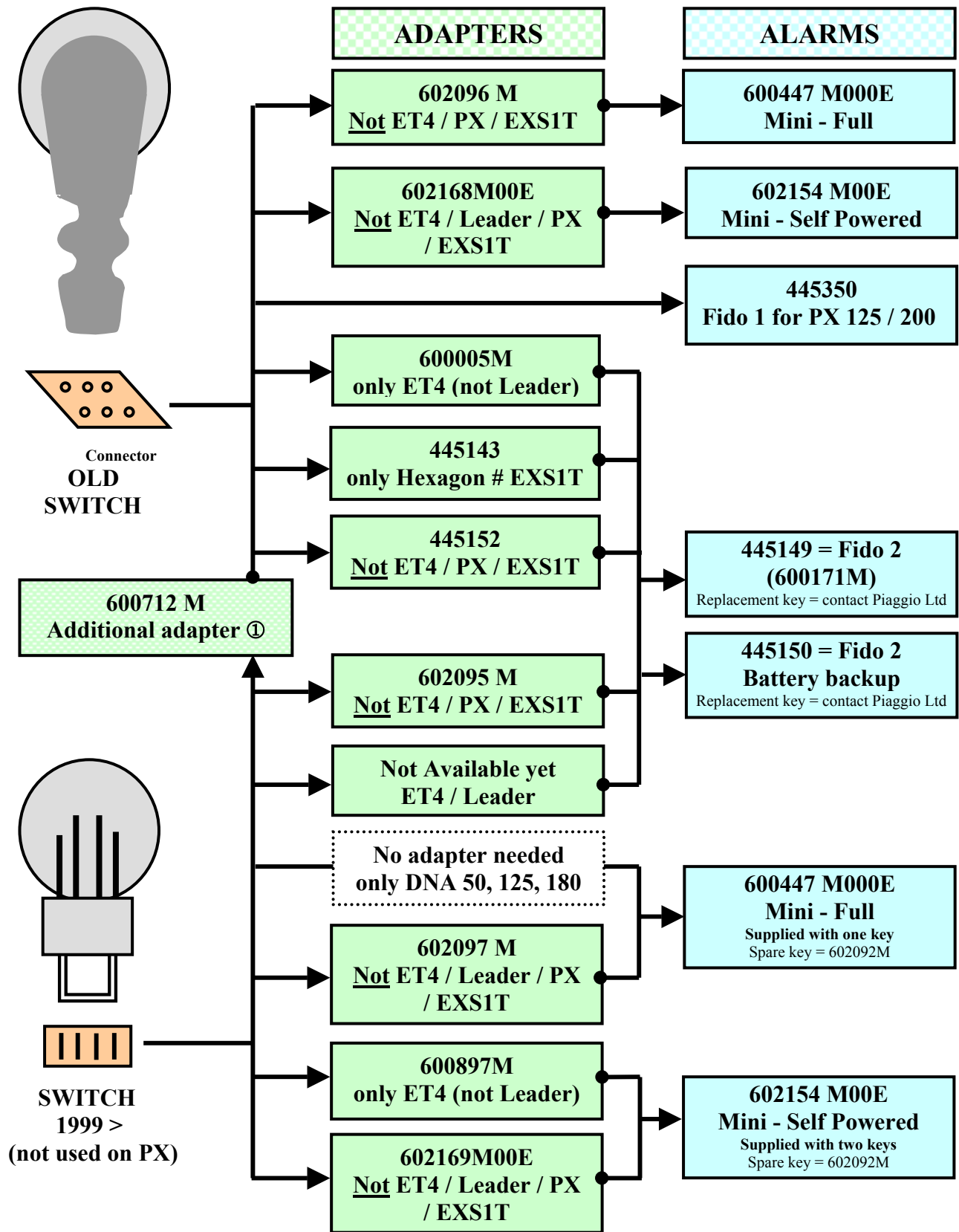

The new LEADER engine has a very different electrical system and an adapter for this is not available yet. **Do not** try to use any existing adapter.

① The additional adapter 600712M is used to convert the old style harness so it can be plugged into the new style ignition switch.

Alarm Information

There are four alarms supplied by Piaggio:

Fido: suitable for Vespa PX

Fido 2: Needs a wiring adapter to connect it to the vehicle wiring. Suitable for many of the older models. Check the fitting list for compatibility.

Mini Full: More compact unit. Needs a wiring adapter. Suitable for many models.

Check the fitting list for compatibility. Mini Full will plug directly into the DNA wiring harness.

Mini Full Self Powered: Similar to Mini Full but with battery back up. The wiring socket is different to the Mini Full and it requires specific wiring adapters. Check the fitting list for compatibility.

Wiring adapters are not currently available for Leader engines. Leader engined vehicles are supplied with an immobiliser as standard. Except the DNA which has a socket to allow the Mini Full to be plugged into it directly.

Programming new keys for Mini Full and Mini Full Self Powered alarms.

Additional keys can be obtained from Fowlers. Part Number is 602092M (Same for both alarms)

Programming:

1. Ignition off.
2. Disconnect the red wire (remove the fuse).
3. Press and hold the anti-theft button (shorts the black/grey wire to earth)
4. Re-connect the red wire while holding the anti theft button.
5. Check that the vehicles LED has come on and the alarm emits a sound.
6. Press the new remote control key button.
7. The alarm should now beep and the LED will turn off. This signals that the code has been accepted.

The alarm can remember up to eight keys at a time. If a ninth key is programmed then the first one will be forgotten.

Additional keys for the earlier Fido and Fido 2 alarms.

Fido and Fido 2 are not of the “rolling code” type so keys have to be matched to the alarm. If you require a replacement key contact Piaggio accessories dept. with the serial number of the alarm and they will contact the manufacturer in Italy.

If you have any problems with these alarms contact Piaggio Ltd. Accessory Department 020 7401 4329.

Remember that a faulty alarm will not be covered by warranty. It is covered by a twelve month guarantee from Fowlers of Bristol.

GILERA KEYS

The following photograph shows the different types of keys used on the recent Gilera models.



Only the Runner VX / VXR has an immobiliser. Note the symbol on the key that denotes an immobiliser chip is fitted.

Later Runner FX / FXR keys look the same as the VX / VXR key but they do not have an immobiliser chip and the symbol is not on the key.

KEY PART NUMBERS

DNA 50 / 125 / 180 = 970239

Runner VX / VXR = 576232 with immobiliser chip

Runner FX / FXR = the shape shown in the picture is 563585 this has been superseded to 576719 this looks like the VXR key but does not have an immobiliser chip.

SKP 50 = 574690

ICE 50 = 576719

Tech Tips. #1 / 2004

1. H@K and GSM fork oil.

Front forks on H@K and GSM need 200cc of 10W fork oil in each leg.

Ref. Mario

2. B 125 Transmission Cover.

It is possible to remove the transmission cover from a B 125 with the engine in the frame. Oh yes it is, say Garozzo M/C of Sidcup.

Remove the cover screws and clutch shaft centre nut as usual. It is now possible to get the cover out far enough to remove the clutch drum. Once the clutch drum is removed it is possible to remove the cover.

Ref. Garozzo M/C

3. X9 500 Tappet adjustment.

It is possible to check / adjust the tappets on an X9 500 with the engine in the frame.

- ❑ Remove r/h foot board / body work.
- ❑ Remove the foot board mounting frame (3 x 6mm bolts)
- ❑ Place a bar or piece of wood under the rear wheel.
- ❑ Take out the top mounting bolt from the right hand rear shock absorber. Then push it forward, pull to one side slightly and pull it as far back as possible.
- ❑ Take out the bottom mounting bolt from the left-hand rear shock absorber. Then push it back as far as possible.
- ❑ You can now raise the rear of the engine high enough to allow access to the rocker box cover and then the tappets. Use a length of wood under the rear tyre as a lever to raise the engine and then block the engine securely.

Ref. Adam

4. 50cc Indicators.

If you find a fairly new 50cc with indicators that flash normally with engine off but become fast or erratic when the engine is running you should also find that a non-resistor plug cap is fitted.

Fitting a resistor cap should cure the problem.

Please note that they do not all have this problem so do not change the cap unless you have the fault.

Ref. Tech Support

5. Pure jet fault code.

The diagnostic fault code list in the service station manual includes G50 P0250. This code should be G50P0251.

Ref. Mario

6. 2004 Colour Codes.

New colours for 2004 and their associated last two digits of the painted item part numbers.

Colour	Code	Part No.	Colour	Code	Part No.
Blue Imperial	204/A	D9	Grey Excalibur	738/A	F2
Red Karcade	811/A	RF	Blue Aurora	422	AA
Grey Cashemere	546	EC	Yellow Lightspeed	908/A	GH
Yellow Cameo	524	BG	Grey Ghiaccio	715/A	BB

Ref. Tech Support

Tech Tips. #2 / 2004

1. 125 leader engine. Poor pick up.

If you find that a scooter with a 125 Leader engine is reluctant to accelerate from stand still particularly when it has not warmed up fully.

Check the tappets, they are probably slightly tight.

Tappets should be inlet: 0.10mm. exhaust: 0.15mm.

Ref. Practical experience

2. X9 250 Evolution. Belt change.

Please note that the drive belt should be changed at 18000km and not 12000km as stated in the Service Schedule. Also the Secondary Air System should be cleaned at 18000km.

Ref: NT12/03

3. DNA 125 / 180. Checking the Tappets.

It is possible to check the tappets without spending a lot of time removing the engine.

- You will be removing one of the engine mounting bolts so first you must find a suitable support to go under the bike in front of the engine (something like a milk crate).
- With the bike supported and the centre stand down remove the lower rear shock absorber bolt.
- Remove the engine mounting bolt that is accessible. Only one of them can be removed.
- Carefully pull the engine backward and twist it slightly as you go. Watch the wires and pipes to make sure nothing is getting caught. The first pipe that will pull tight is one of the small black rubber cooling pipes.
- You will be able to pull and turn the engine far enough to give good access to the rock box bolts. Once the bolts are out it is easy to remove the cover and check the tappets.
- Inlet:- 0.10 mm. Exhaust:- 0.15 mm.

Practical experience.

4. Runner Purejet. Cutting out / loosing power.

We have had a report from BMG Scooters that if the rear suspension of a Runner Purejet is fully compressed it is possible for the Throttle Position Sensor plug to hit the bottom of the helmet compartment. The plug does not come out but if the connection is lost the engine will revert to idle speed and the throttle will not respond. Please let us know if you have experienced this problem.

BMG.

5. Purejet. Using cheap 2 stroke oil.

The owner's handbook and Service Station Manual say that fully synthetic oil must be used.

If cheap oil is used more carbon is produced in the combustion chamber. Specks of carbon on the head of the injector valve and the carbon on the cylinder head can disrupt the dispersal of fuel enough to make the engine run very badly. Also cheap oil will not give such good lubrication.

These engines have proved to be very reliable when they are used correctly but remember that they are running on a very weak fuel mixture and very little oil to make them clean burning and incredibly economic.

Please take time to explain the importance of using fully synthetic oil to your customers.

Practical experience.