



Sales division  
Technical network leadership

# WORKSHOP MANUAL



**50CC ENGINE  
HORIZONTAL LIQUID-COOLED CYLINDER**



**TABLE OF CONTENTS**

<b>TABLE OF CONTENTS.....</b>	<b>1</b>
<b>CHARACTERISTICS.....</b>	<b>3</b>
Engine.....	3
Capacities.....	3
Engine marking.....	3
<b>SPECIAL IMPORTANT POINTS.....</b>	<b>4</b>
Oil and fuel.....	4
<b>TIGHTENING TORQUES.....</b>	<b>5</b>
<b>SPECIAL TOOLS.....</b>	<b>6</b>
<b>DISASSEMBLY.....</b>	<b>8</b>
Putting the engine on the stand.....	8
Removal of the carburettor.....	8
Removal of the air pump.....	8
Removal of the water pump.....	9
To remove the magneto flywheel.....	9
Removal of the stator and engine speed sensor assembly.....	10
Removal of the primary transmission cover.....	10
Removal of the drive pulley.....	10
Removal of the driven pulley.....	11
Removal of the secondary transmission cover.....	12
Removal of the secondary transmission.....	12
Removal of the starter motor.....	13
To remove the cylinder head/cylinder assembly.....	13
Removal of the piston.....	13
Removal of the thermostat.....	14
Removal of the temperature sensor.....	14
To remove the inlet manifold and valve.....	15
Opening the engine casings.....	16
Removal of the crankshaft.....	17
Checking the crankshaft and conrod assembly.....	18
<b>REFITTING SPECIFIC COMPONENTS.....</b>	<b>19</b>
Fitting the crank assembly bearings.....	19
Assembly of the engine casings.....	21
Fitting the piston.....	23
Fitting the cylinder.....	24



Fitting the cylinder head.....	24
To fit the magneto flywheel. ....	25
Fitting the water pump.....	25
Fitting the air pump. ....	26
Fitting the starter motor dog.....	26
<b>MISCELLANEOUS OPERATIONS .....</b>	<b>28</b>
Fitting the drive pulley assembly. ....	26
Removal of the starter system. ....	28
Fitting the starter system. ....	29
Changing the drive pulley bearings.....	29
Removal of the clutch lining assembly. ....	30
Refitting the clutch lining assembly. ....	31
Removal of the carburettor.....	32
Removal of the throttle valve.....	32
Removal of the electric choke. ....	33
Removal of the float, needle valve and jets.....	33
Removal of the engine speed adjuster screw and mixture control screw .....	34
<b>REFITTING SPECIFIC COMPONENTS.....</b>	<b>36</b>
Re-fitting the jets, float and needle valve. ....	36



**CHARACTERISTICS.****■ Engine.**

<b>Engine.</b>	2-stroke single-cylinder.
<b>Cooling.</b>	Liquid.
<b>Bore x stroke.</b>	39.9 x 39.8 mm.
<b>Cubic capacity.</b>	49.9 cc.
<b>Max. power output.</b>	3.6 kW at 7300 rpm.
<b>Max. torque rating.</b>	7000 rpm.
<b>Ignition.</b>	CDI.
<b>Spark plug.</b>	NGK CR7EB.
<b>Magneto flywheel.</b>	Kokusan 89W.
<b>Starter motor.</b>	Mitsuba 150W or Moric 160W.
<b>Air pump.</b>	Mechanical Dell'Orto.
<b>Carburettor.</b>	Carburettor Gurtner PY 15.
<b>Oil pump.</b>	Electric Dell'Orto.
<b>Oil pump control unit.</b>	Electric Dell'Orto.
<b>Transmission.</b>	By 2 variable pulleys and V-type belt.
<b>Clutch.</b>	Centrifugal automatic.
<b>Exhaust.</b>	Catalytic.

**■ Capacities.**

<b>Relay box.</b>	0.12 l SAE 80W90 life lubricated.
-------------------	-----------------------------------

**■ Engine marking.**

<b>Engine type.</b>	HL2.
---------------------	------



## **SPECIAL IMPORTANT POINTS**

### ■ Oil and fuel.

This engine is designed to run on 95 or 98 unleaded fuel only.

The oil to use for the separate lubrication system is "Esso 2T Special" or "Esso 2T Special low-smoke" oil approved by the manufacturer.

Oil is injected straight into the carburettor by an electric pump, command-driven by a control unit.



**Petrol is highly inflammable, do not smoke in the working area and avoid proximity to flames or sparks. Work in a clear and well-ventilated area.**

---







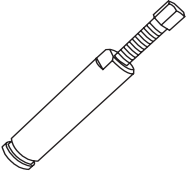
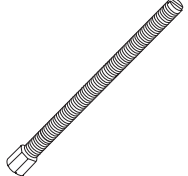
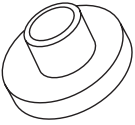
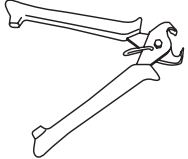
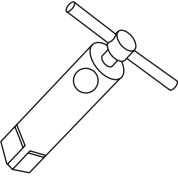
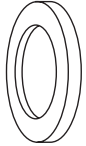

**TIGHTENING TORQUES**

Spark plug.	1 m.daN.
Engine speed sensor.	1 m.daN.
Cylinder casings.	1 m.daN.
Transmission cover.	1 m.daN.
Cylinder head.	1.2 m.daN.
Starter motor.	1 m.daN.
Clutch plate and shoes.	4 m.daN.
Air pump.	0.7 m.daN.
Water pump.	1 m.daN.
Drive pulley.	4 m.daN.
Driven pulley.	4.5 m.daN.
Inlet manifold.	1 m.daN.
Rotor.	4 m.daN.
Stator.	1 m.daN.

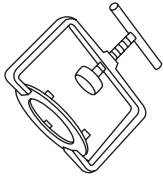

**SPECIAL TOOLS**

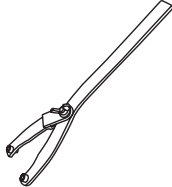
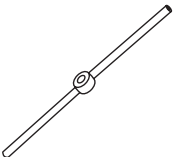
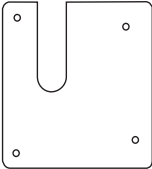
	Tool N°.	Designation.	Used with.		Tool N°.	Designation.	Used with.
	64706	Casing extractor and opening tool.	754006 750069		750069	Pin Ø10 pitch 125.	69104
	64710	Shouldered centering tool.	64706		750539	Tie-wrap pliers.	
	64765	Engine mount.	755982		750808	Thrust washer.	64706
	68007	Protective end-piece small model.	755985		752000	Piston circlip pliers.	
	068994	Torque wrench 8 N.m to 54 N.m.	752235 752236		752127	Clutch compression tool.	756725
	69098	Protective end-piece large model.	64706		752237	Adjustable pin wrench.	
	69104	Pin nut.	750069		754006	Modified casing opening plate.	64706

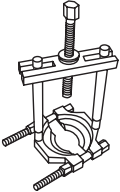
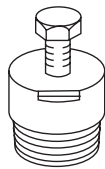
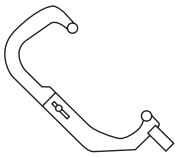
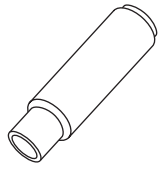
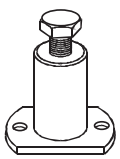
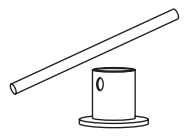

	755585	Bearing extractor tool.	755585		755985	Flywheel puller.	68007
	755982	Engine mount adapter.	64765		756668	Crank assembly lip seal tool.	
	755983	Casing opening tool.	68007		756725	38 mm pipe wrench.	752127



**DISASSEMBLY****■ Putting the engine on the stand.**

- Fit the engine to adapter P/N 755982.
- Put the assembly on stand P/N 64765 clamped in the jaws of a vice.

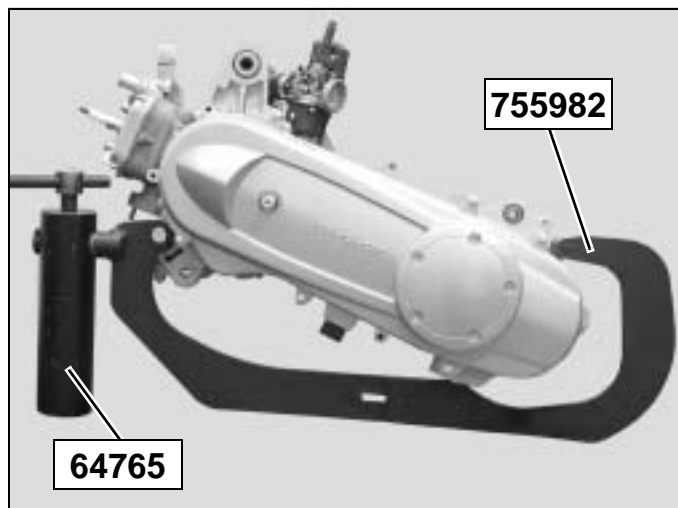
**■ Removal of the carburettor.**

- Remove the click-type collar (1).
- Remove the carburettor.

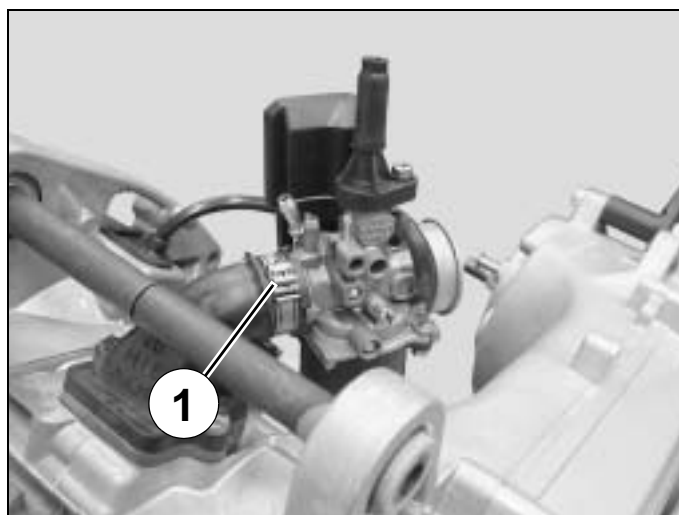
**■ Removal of the air pump.**

- Remove the 4 screws (1) that secure the air pump (2).
- Remove the air pump.

**Tightening torque: 0.7 m.daN.**

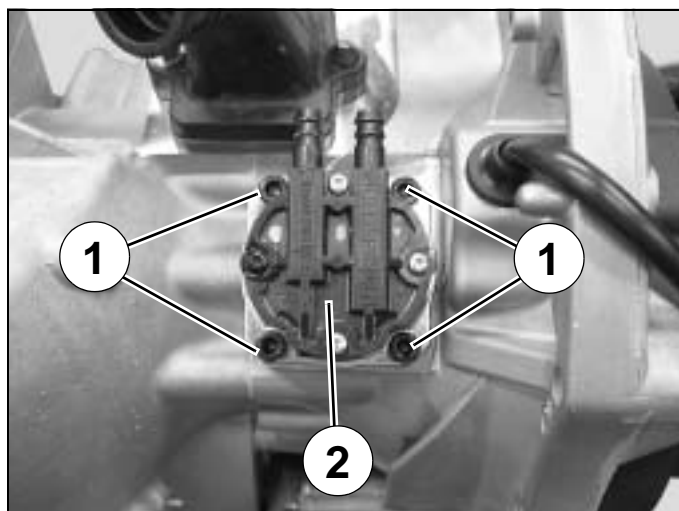

### ■ Removal of the water pump.

- Remove the pump/cylinder cooling system hose (1).
- Remove the water pump (3) 3 fixing bolts (2).
- Remove the water pump.

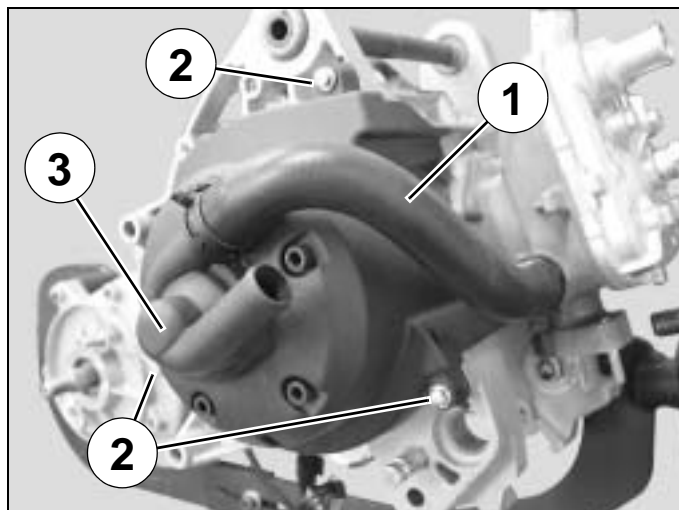

### ■ To remove the magneto flywheel.

- Remove the 2 pins that drive the water pump.
- Hold the rotor (1) with the pin wrench P/N 752237.
- Remove the nut.

**Tightening torque: 4 m.daN.**

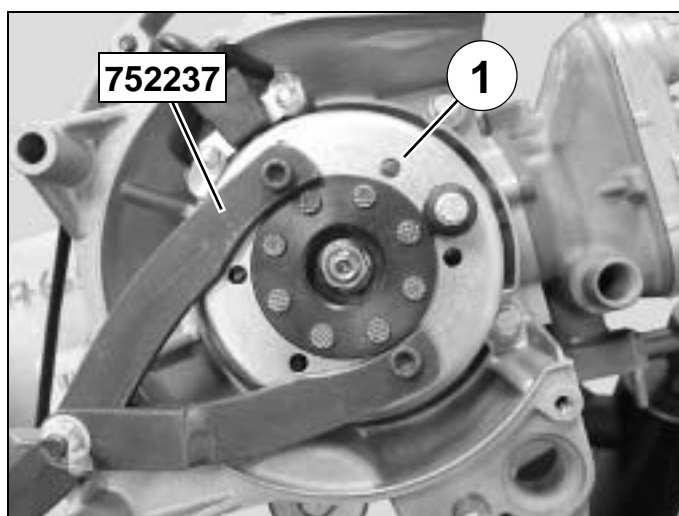

- Fit protective cap P/N 68007 to the end of the crank assembly.
- Tighten flywheel extractor P/N 755985 on the rotor.
- Lock the flywheel extractor and turn the thrust bolt until the rotor is released.

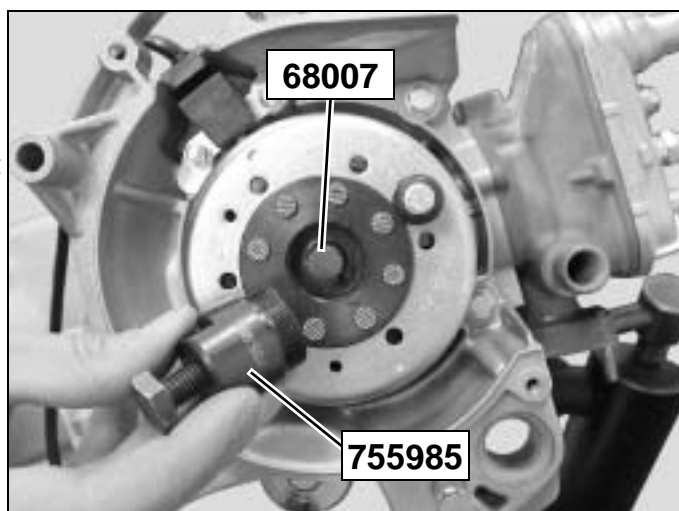

### ■ Removal of the stator and engine speed sensor assembly.

- Remove the engine speed sensor 2 fixing bolts (1) and the stator assembly 2 fixing bolts (2).
- Remove the stator and sensor assembly (3).
- Remove the key (3) from the crank.

**Tightening torque: 1 m.daN.**

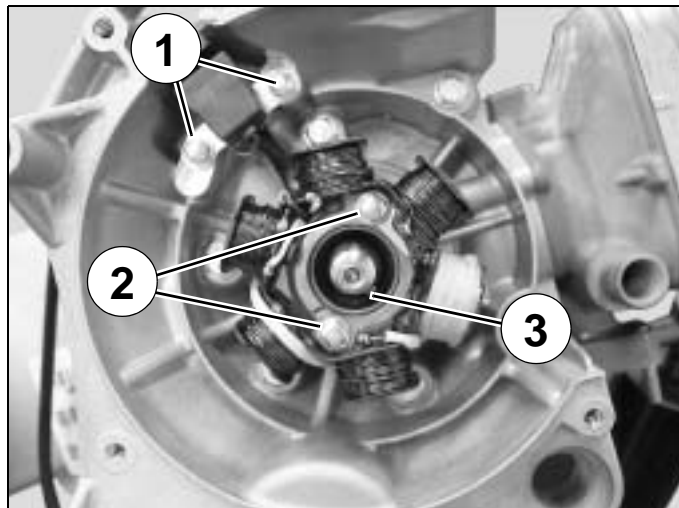

### ■ Removal of the primary transmission cover.

- Remove the transmission cover 6 fixing bolts.
- Remove the stand (1) cover and the rubber buffer.

**Tightening torque: 1 m.daN.**

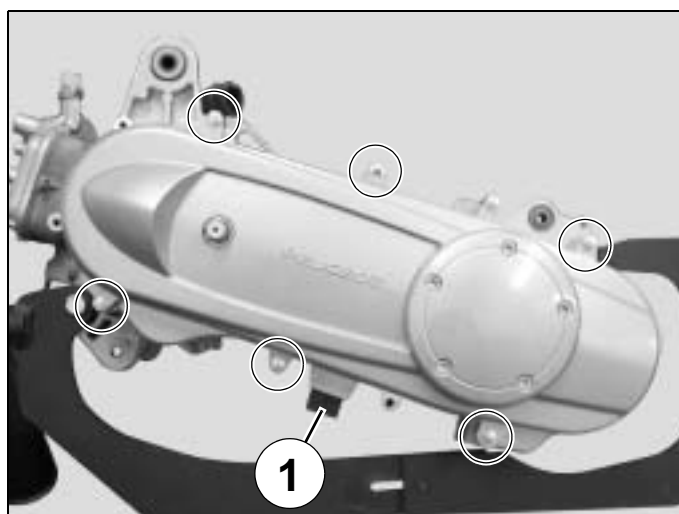

### ■ Removal of the drive pulley.

- Lock the fixed flange (1) with tool P/N 752237.
- Remove the fixed flange nut and washer.
- Remove the fixed flange.

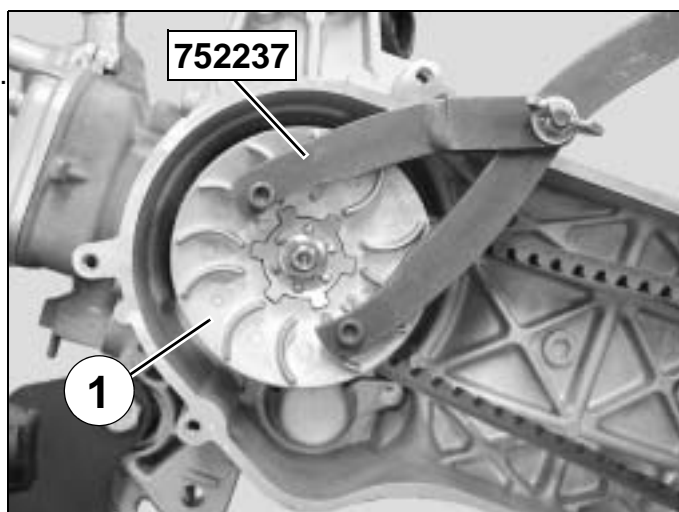

- Remove the belt.
- Remove the drive pulley (2) with the guide hub (3).

**Tightening torque: 4 m.daN.**

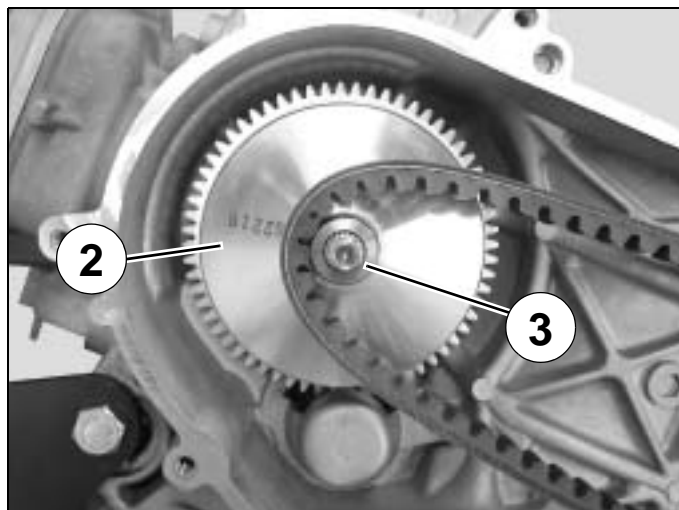

- Remove the starter dog (7) bush (6) fixing bolt (5).
- Remove the bush.

**Tightening torque: 1 m.daN.**

- Remove washer (8).
- Remove the starter ring (9).
- Remove the starter dog.

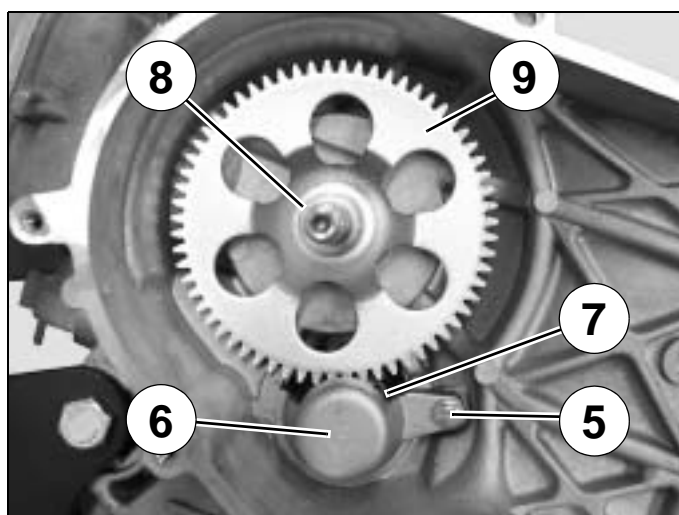

### ■ Removal of the driven pulley.

- Lock the clutch drum (1) with the pin wrench P/N 752237.
- Remove the nut.
- Remove the clutch drum and the clutch and drive pulley assembly.

**Tightening torque: 4.5 m.daN.**

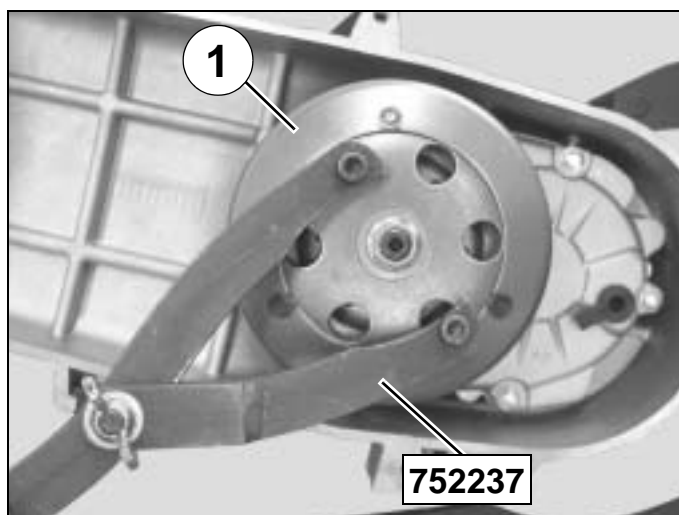

### ■ Removal of the secondary transmission cover.

**Note:** Use a drip pan to catch the transfer box oil when the cover is removed.

**Filling and checking the transfer box oil level is through the cap (3).**

- Remove the 6 bolts that secure the cover.
- Remove the cover with the primary shaft.



### ■ Removal of the secondary transmission.

- Remove the paper gasket (1) and the 2 locating pins (2).
- Remove the first friction washer (3) from the intermediate shaft (4).
- Remove the secondary shaft (5).

**Note:** Take care not to damage the seal on the wheel side when removing the secondary shaft, as the oil could leak out through a drain hole in the casing located between the seal on the wheel side and the bearing.

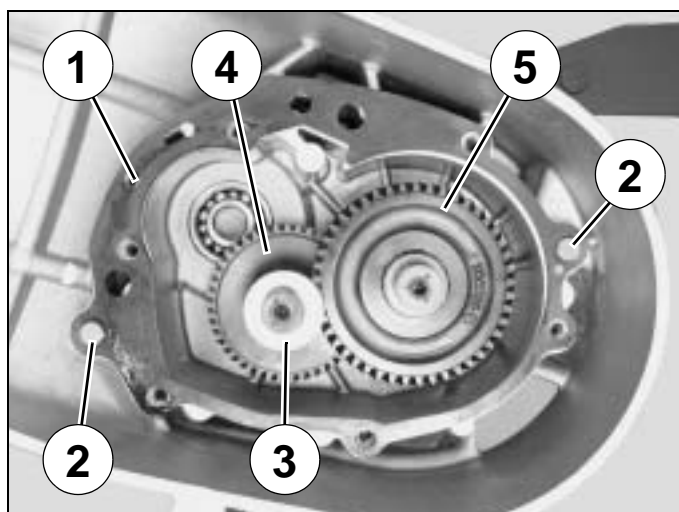

- Remove the intermediate shaft and its second friction washer (6) (14x27x0.5) located behind it.

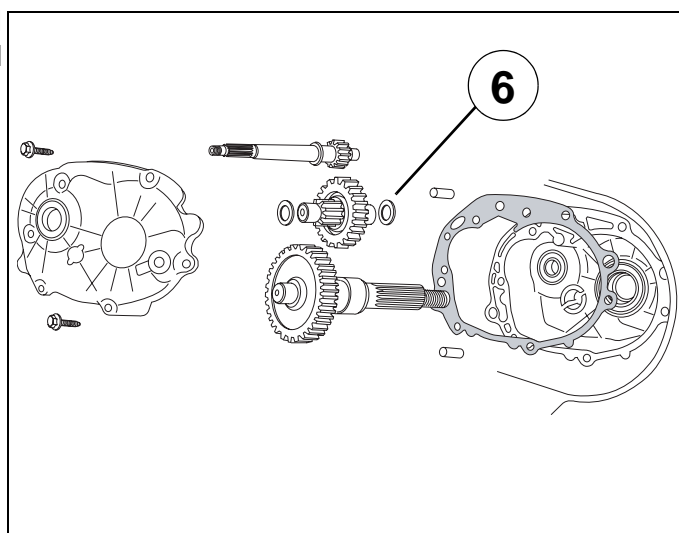

### ■ Removal of the starter motor.

- Remove the starter motor (2) 2 fixing bolts (1) and washers.
- Remove the starter motor and its O-ring.

**Note:** The lower bolt is used for the engine earth (green wire connected to the battery negative terminal).

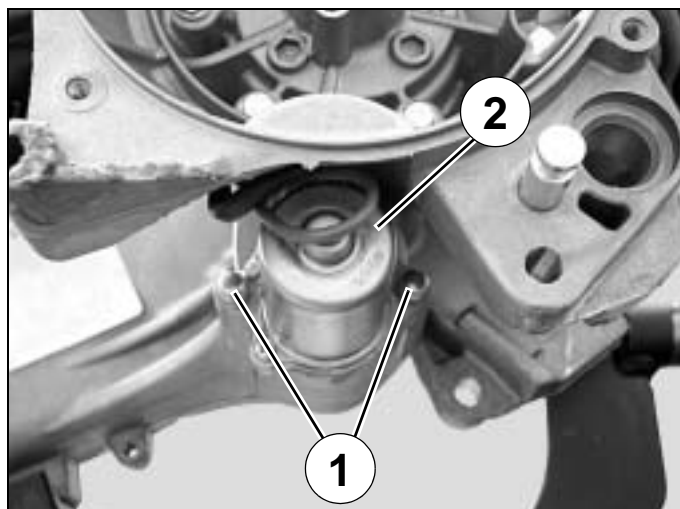

### ■ To remove the cylinder head/cylinder assembly.

- Loosen the attachment screw (1).
- Slacken off the cylinder head/cylinder 4 mounting bolts in the order shown, in 2 or 3 stages.
- Remove the 5 bolts.
- Remove the cylinder head and its gasket.
- Remove the cylinder and its bottom seal.

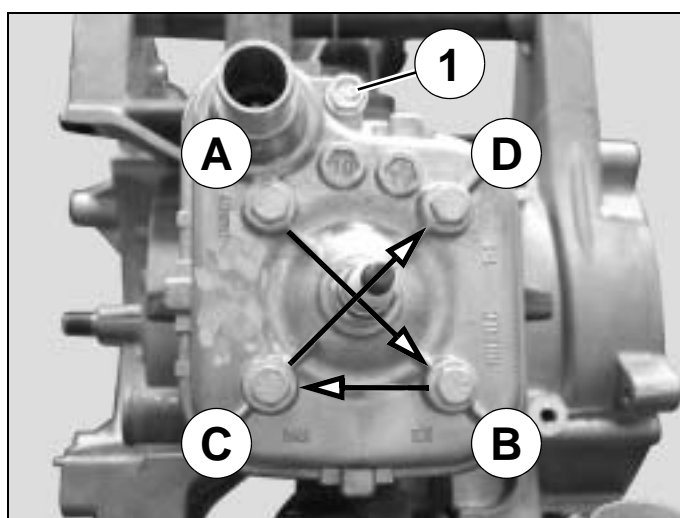

### ■ Removal of the piston.

- Remove one of the spring clips (1) using pliers P/N 752000.
- Remove the gudgeon pin.
- Remove the piston.
- Remove the needle bearing race from the connecting rod end.

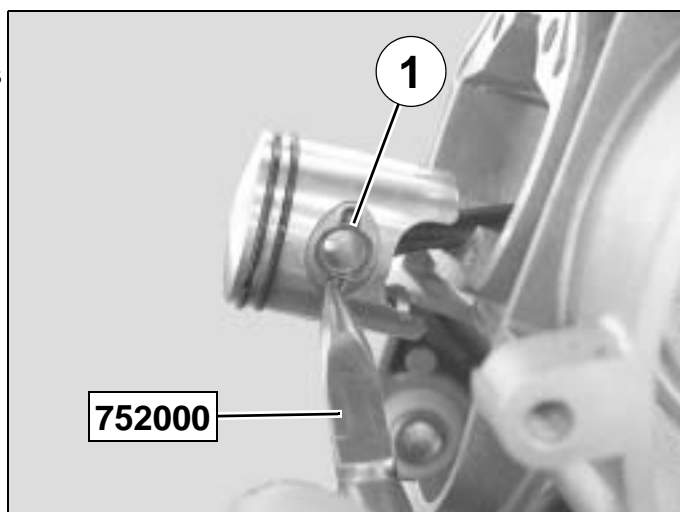

■ **Removal of the thermostat.**

- Remove the circlip (1) from the thermostat (2).
- Remove the thermostat.

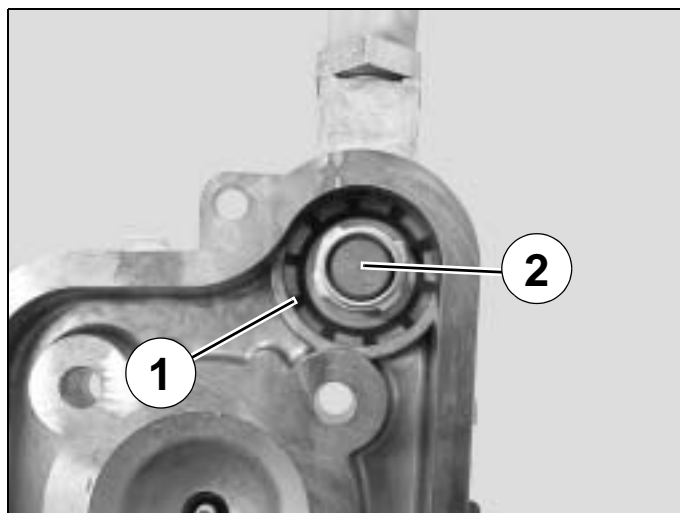

**Note:** When refitting, ensure the circlip is correctly positioned.

The thermostat circlip must be changed each time it is removed.

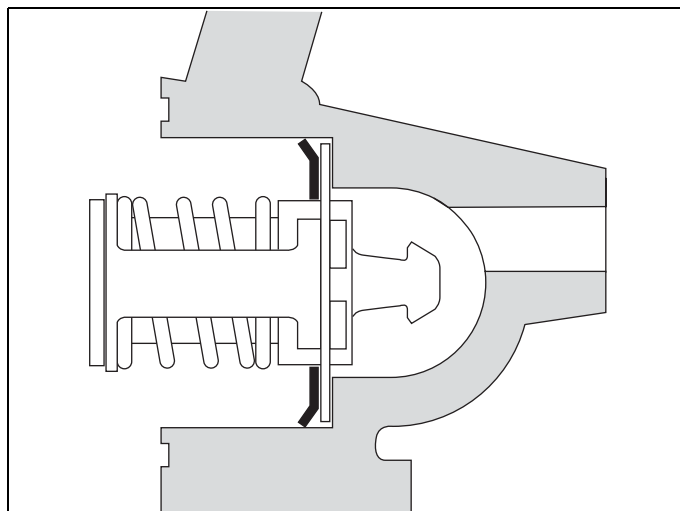

■ **Removal of the temperature sensor.**

**Note:** The engine temperature sensor (1) seal is provided by a steel gasket.

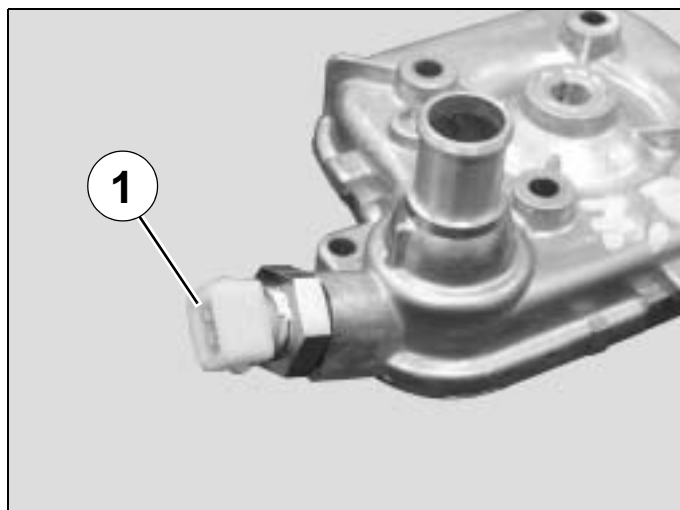



■ **To remove the inlet manifold and valve.**

- Remove the inlet manifold (2) 2 fixing bolts (1) (one of which is tamper proof).
- Remove the inlet coupling.

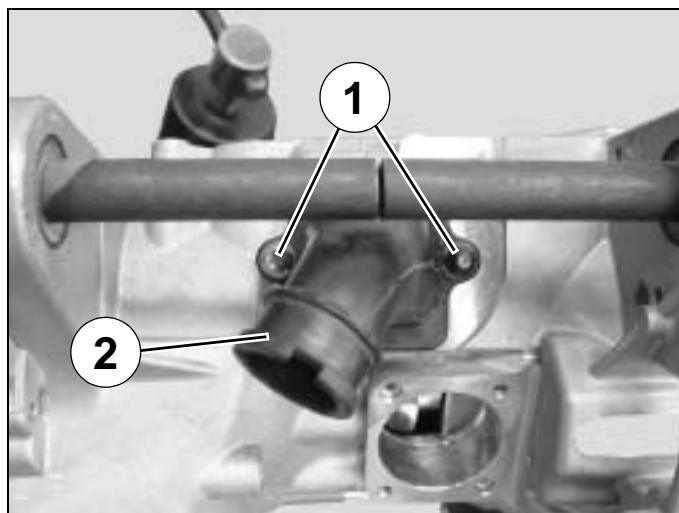

- Remove the valve assembly (3).
- Remove the composite material filled gasket (4).

**Tightening torque: 1 m.daN.**

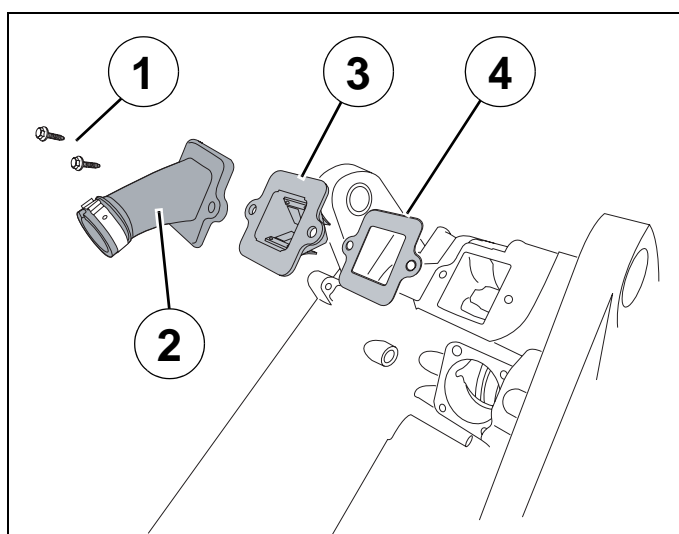

**Note: The O-ring must be changed every time it is removed.**

**Check that the valve assembly blades and support are in perfect condition.**

**Note: The position of the limiter must be  $6.2 \pm 0.3$  mm from the valve support.**

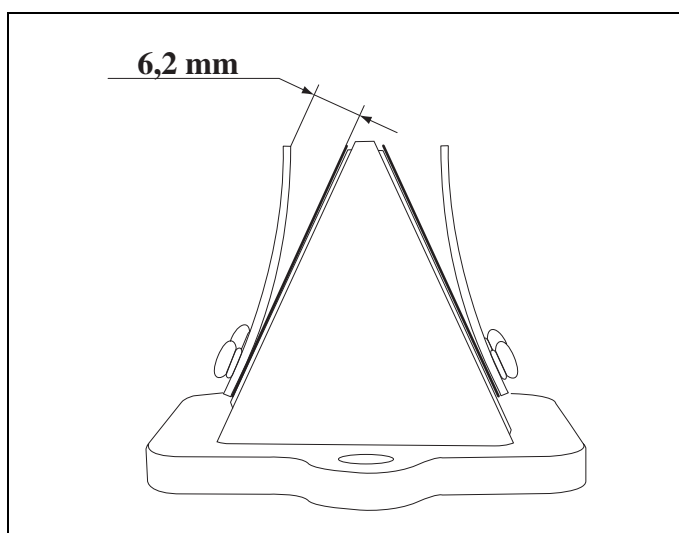

### ■ Opening the engine casings.

- Remove the RH casing (2) 6 fixing bolts (1).

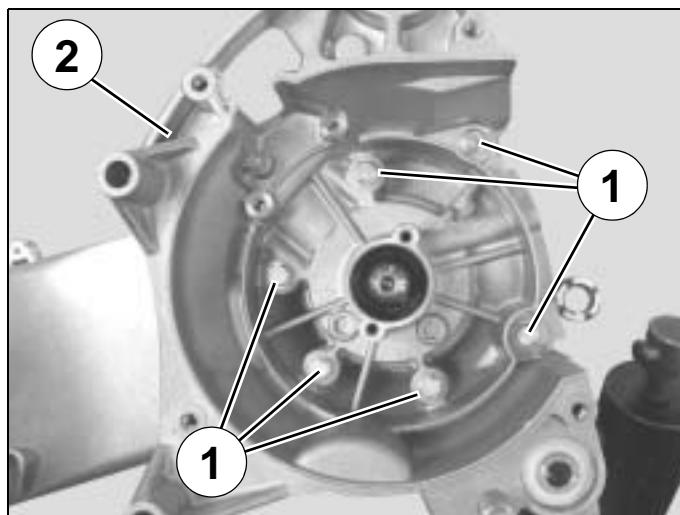

- Fit the protective cap P/N 68007 to the crank.
- Fit to the RH casing tool P/N 755983 secured by 2 bolts.
- Hold the connecting rod to prevent it from coming into contact with the casings.
- Tighten the tool centre screw until the casings separate.

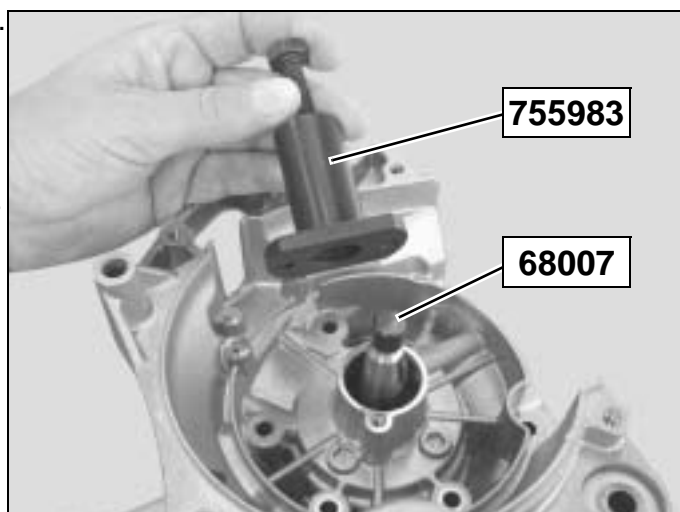

- Remove the RH casing.
- Remove the 2 centring pins (3) and the gasket (4).

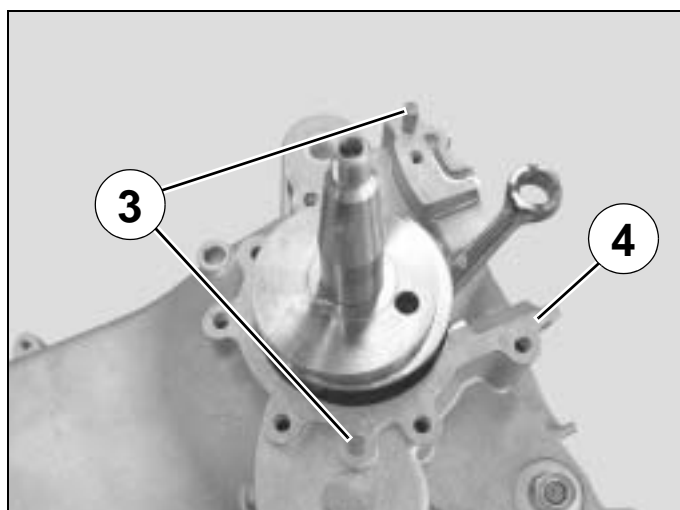

### ■ Removal of the crankshaft.

- Fit the protective cap P/N 69098 to the crank.
- Fit to the casing tool P/N 64706 fitted with plate P/N 754006 modified as described in the "Special Tools" chapter.

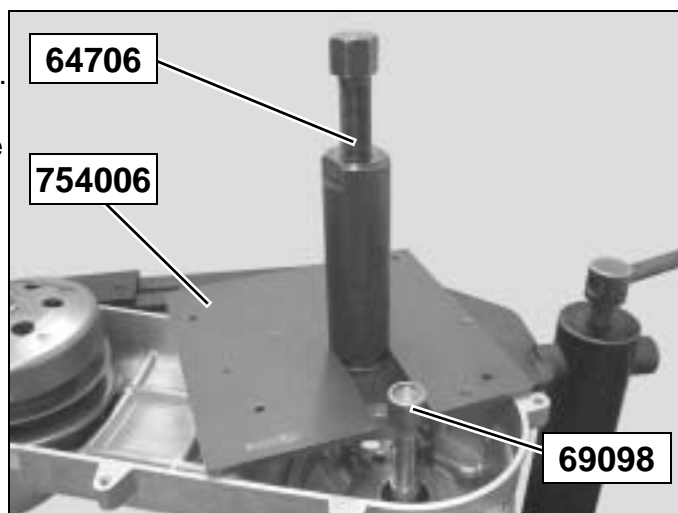

- Fit the complete unit by means of 4 screws (1) (the opening of the plate shall be towards the cylinder).
- Tighten the tool centre screw holding the crank with one hand on the other side until it is fully extracted.

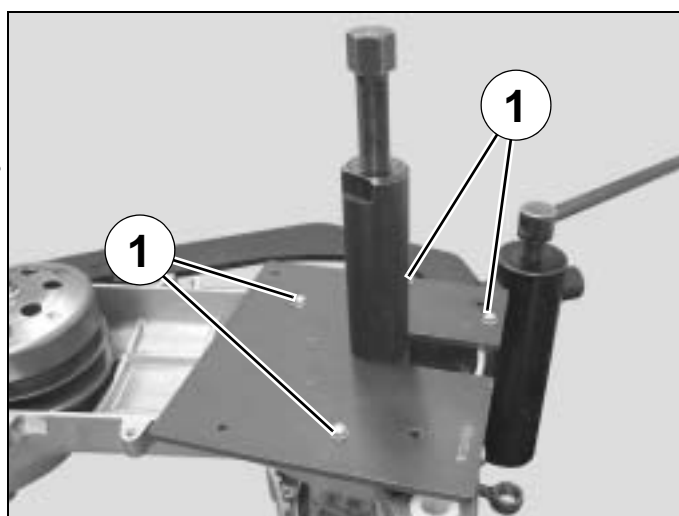

**■ Checking the crankshaft and conrod assembly.**

- Using a set of shims, check the big end side play.
- The maximum side play on the conrod end must not exceed: 7/10 mm.

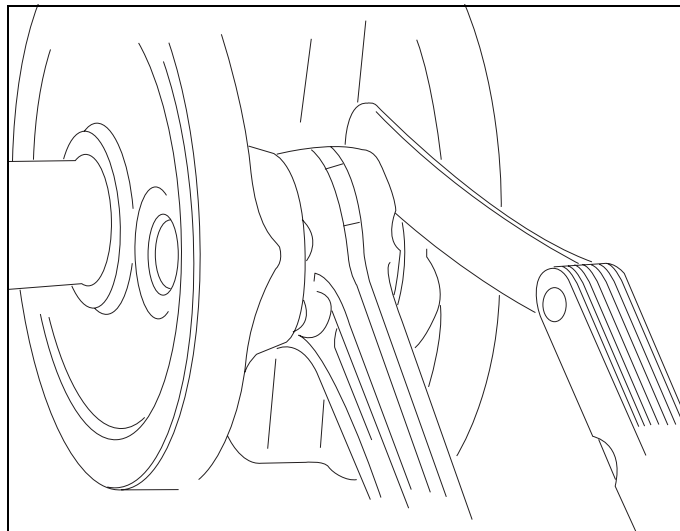

- The runout at the crankshaft ends shall not exceed 5/100 mm and shall be measured at:
  - 50 mm from the transmission side end.
  - 50 mm from the flywheel magneto end.

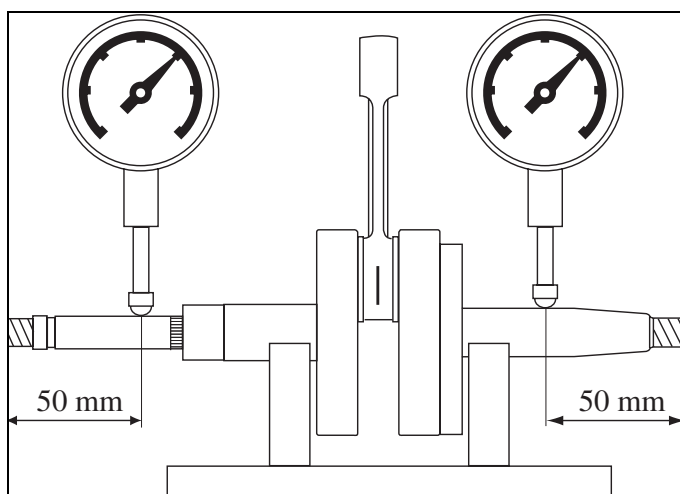

**REFITTING SPECIFIC COMPONENTS****■ Fitting the crank assembly bearings.**

**Note:** The bearings and crank seals must be changed each time the engine casings are opened.

When the casings are opened, if the bearings stay on the crank, use tool P/N 755585 to remove them.

If the bearings stay in the casings, the casings should be heated with a heat gun to remove them.

This operation should be done quickly in order to remove and refit a bearing to each casing.

**Note:** Tool P/N 756668 is used for fitting the two seals. Each end of the tool is designed for fitting one of the seals.

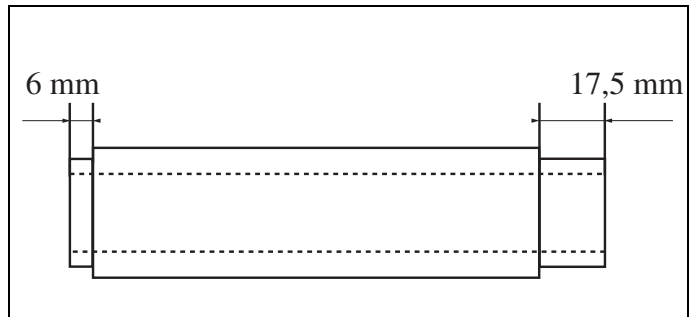

- Set one of the casings (1) on its mating surface, heat it (80 to 90°C) until the bearing drops out of its own accord.
- Remove the seal.
- While the casing is expanded fit the new bearing (2) fully home in its housing.
- Fit a new seal (3) in each casing using tool P/N 756668.
- The seals should be positioned as follows:
  - The seal on the drive pulley side at  $6^{\pm 0.5}$  mm from the outer edge of the casing (LH engine casing).

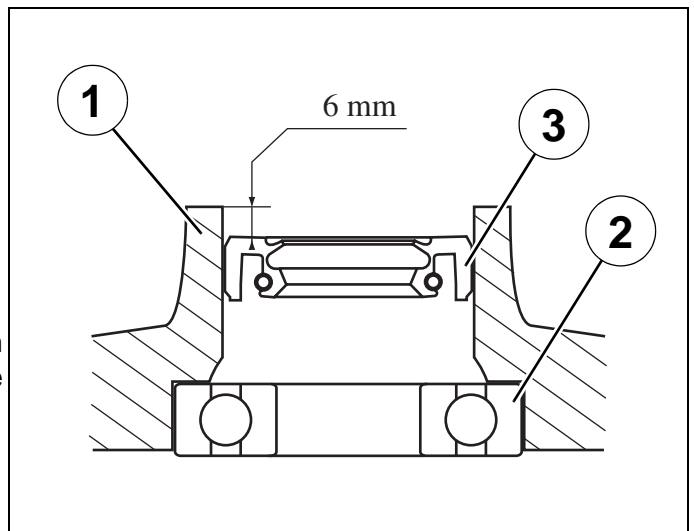

- The seal on the magneto side at  $17.5 \pm 0.5$  mm from the outer edge of the casing (RH engine casing).

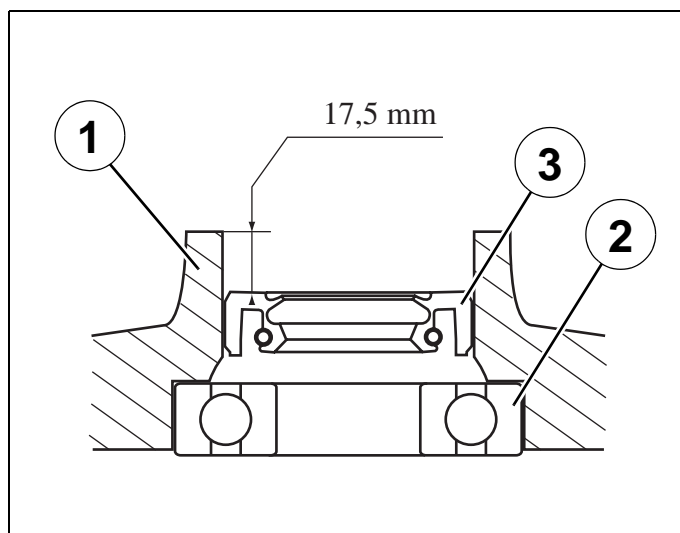

### ■ Assembly of the engine casings.

- Insert the crank assembly into the LH casing bearing.
- Tighten pin P/N 750069 at the end of the crank assembly.
- Fit tool P/N 64706 fitted with plate P/N 754006 to the pin.

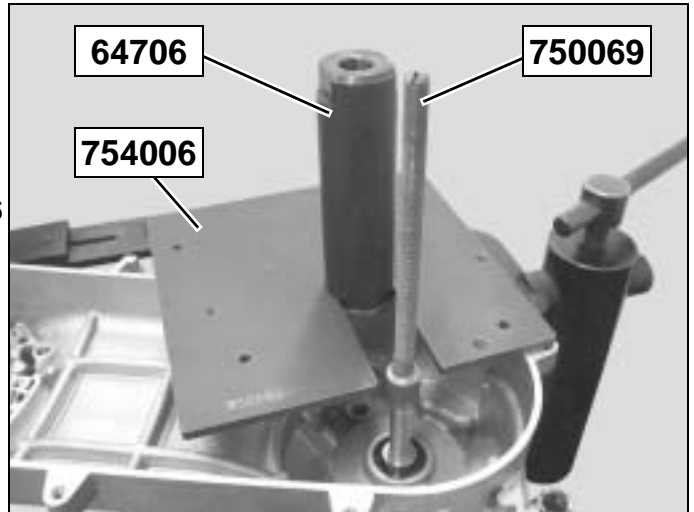

- Fix the assembly to the casing using 4 bolts (1).
- Fit centring tool P/N 64710 to tool P/N 64706.
- Tighten pin nut P/N 69104 on pin P/N 750069 in order to bring the crankshaft assembly into contact with the bearing ensuring that the crank is pointing towards the cylinder side.

**Note: Hold the crank assembly by the RH side using the rotor fitted on the key.**

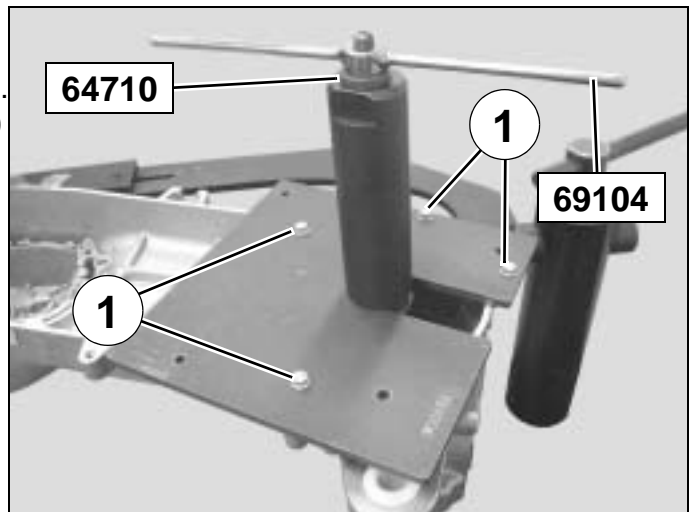

- Fit the 2 centring pins (2) to the LH casing and a new paper gasket (3) do not use oil or grease.

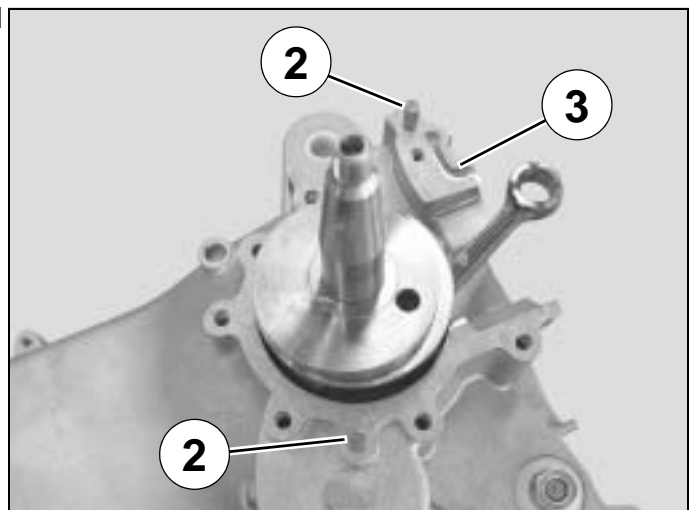

- Fit the RH casing to the LH casing and crank assembly taking care not to damage the seal, over the key if the key has stayed on the crank.
- Tighten pin P/N 750069 at the end of the crank assembly.
- Fit the following in order to the casing:
  - The washer 750808 (50x29x3mm).
  - Tool P/N 64706.
  - Centring tool P/N 64710.
- Tighten pin nut P/N 69104 until the casings are fully closed.

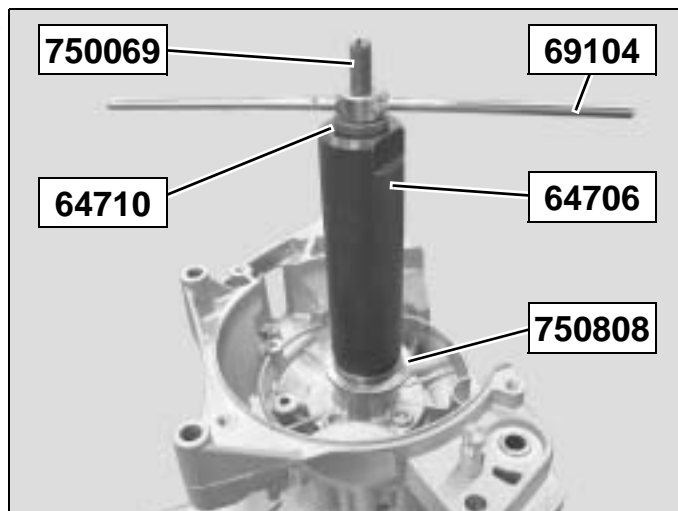

**Note: Hold the crank assembly by the fixed flange fitted to the splines.**

- Fit and tighten the 6 fixing bolts (1).

**Tightening torque: 1 m.daN.**

- Check the crank assembly turns freely in the casings.

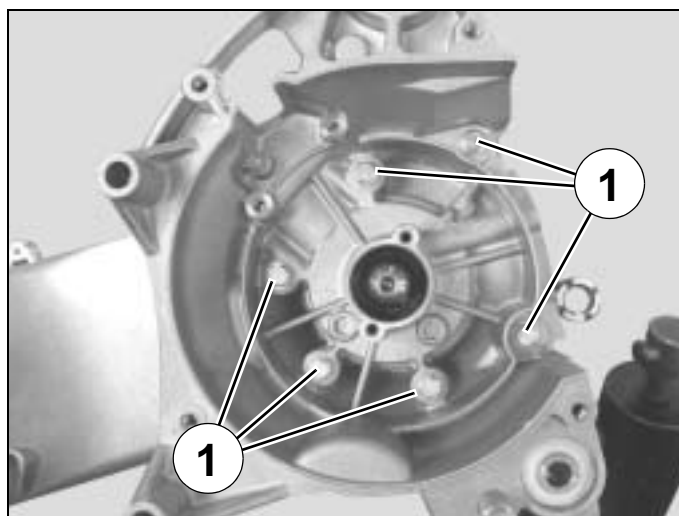

- Cut the casing seal flush at (A) and (B).
- Lightly grease the crank assembly and bearings with 2 stroke oil.

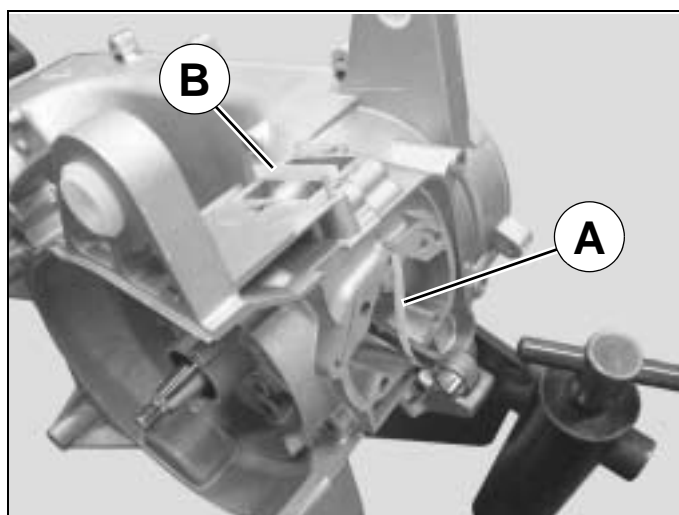



### ■ Fitting the piston.

- Check the cylinder/piston assembly pairing (A).

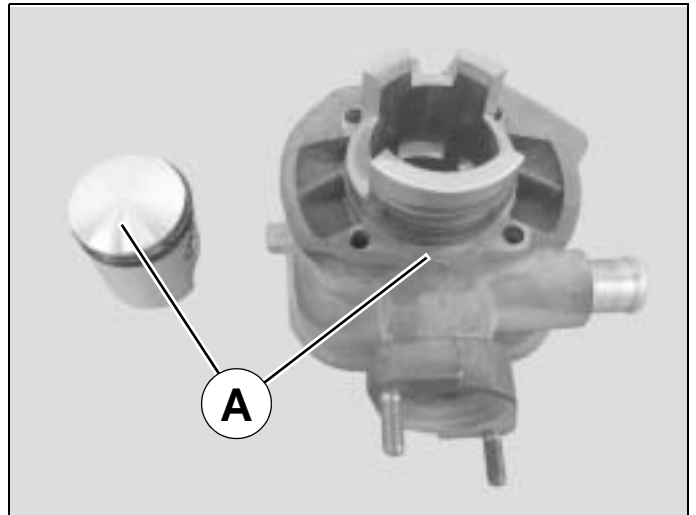

- Fit the needle bearing race (1) into the connecting rod little end after lubricating it with 2 stroke oil.
- Fit the piston to the connecting rod, the positioning spigots on the piston rings facing the inlet side.
- Fit the gudgeon pin and circlips.

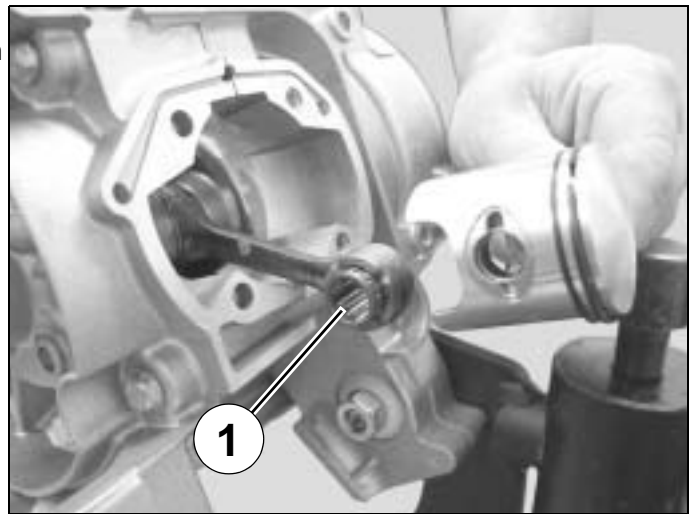

**Important: The circlips must be changed every time they are removed.**

**The circlip gaps (2) must face upwards or downwards, but under no circumstances to the side.**

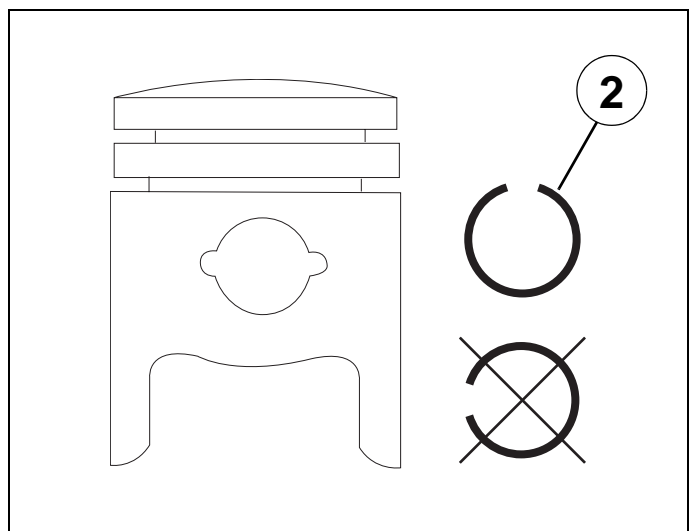

### ■ Fitting the cylinder.

- Fit a new base gasket (1) on the cylinder while respecting the direction of installation, without using any oil or grease.
- Ensure that the piston ring gaps are opposite the piston positioning spigots.
- Fit the cylinder (2) and insert it while compressing the piston rings by hand.
- Check the bottom seal is properly positioned on the casing using 1 cylinder head fixing screw (3)

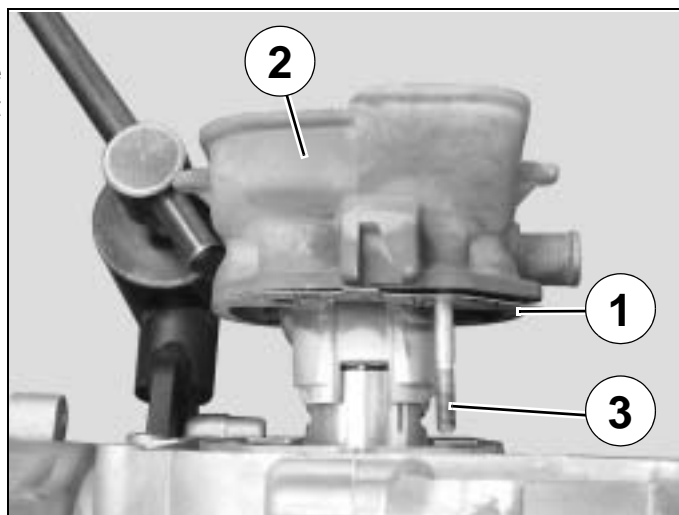

### ■ Fitting the cylinder head.

- Make sure the cylinder head gasket seat is in perfect condition.
- Fit the 4 clamping screws on the cylinder head.
- Fit the cylinder head gasket on the cylinder head.

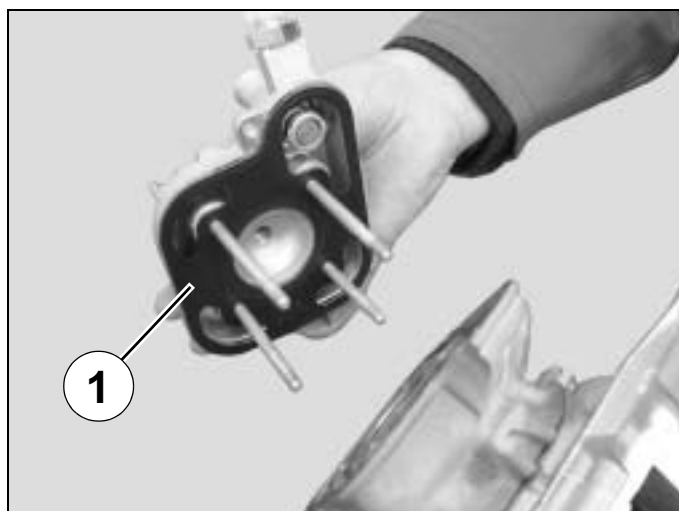

- Fit the screws, gasket and cylinder head assembly on the cylinder.
- Tighten in 2 or 3 sequences the 4 screws that secure the cylinder head in the indicated direction.
- This is carried out in two steps:
- Pre-tighten the screws to a torque of 0.8 m.daN.

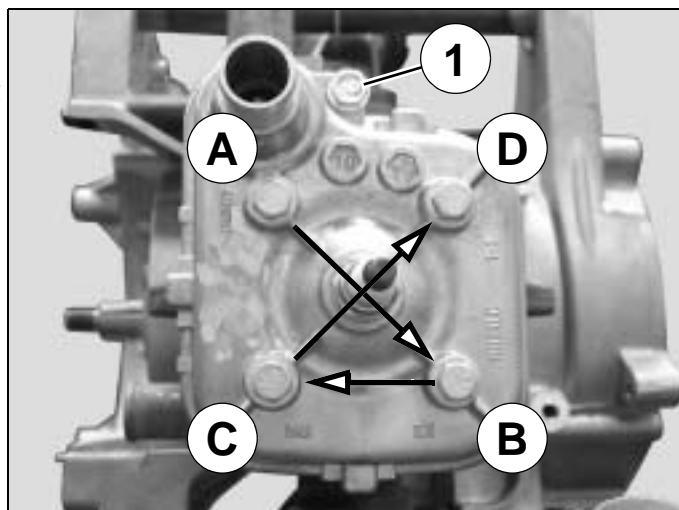

### Final tightening torque: 1.2 m.daN.

- Fit and tighten the cylinder head-to-cylinder clamping screw (1).

### Tightening torque: 1 m.daN.



### ■ To fit the magneto flywheel.

- Fit the key (1) to the crank.
- Fit the stator and engine speed sensor assembly (2).
- Fit and tighten the stator assembly 2 fixing bolts (3).

**Tightening torque: 1 m.daN.**

- Fit and tighten the 2 screws (4) that secure the engine speed sensor.

**Tightening torque: 1 m.daN.**

- Fit the rotor to the crank ensuring it is positioned on the key.
- Lock the rotor with the adjustable pin wrench P/N 752237.
- Fit and tighten the rotor nut.

**Tightening torque: 4 m.daN.**

- Fit the 2 pins that drive the water pump.

**Tightening torque: 0.7 m.daN.**

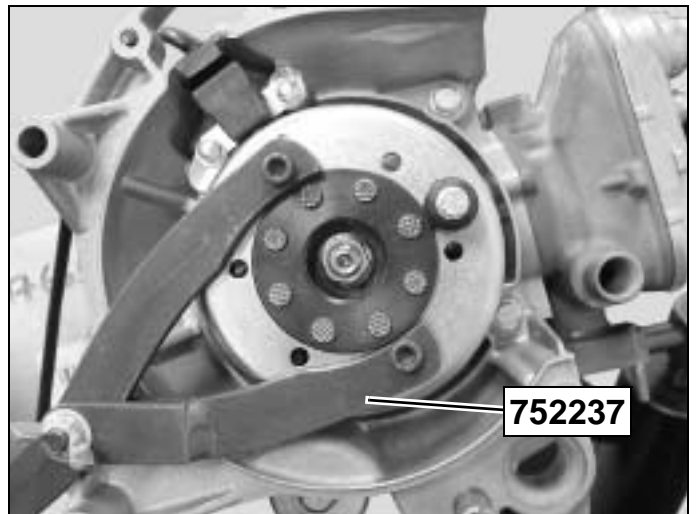
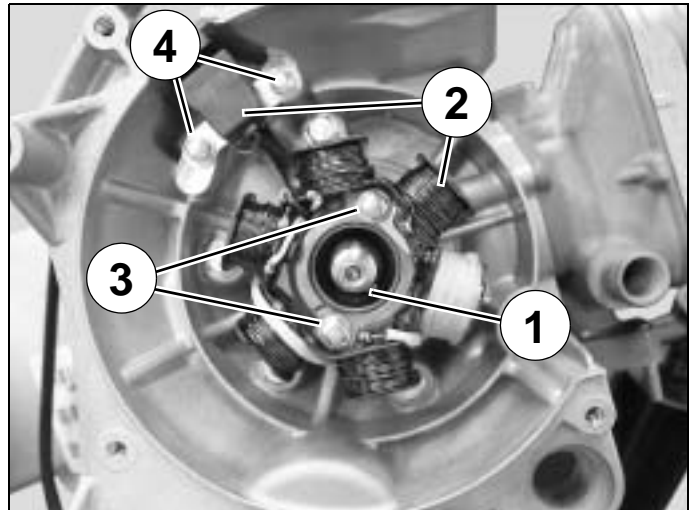

### ■ Fitting the water pump.

- Fit the pump ensuring it is correctly positioned both on the engine casing and the magneto rotor.
- If need be, rotate the crankshaft ass'y in order to make it easier to fit the rotor pins into the water pump's guide holes.
- Fit and tighten the 3 screws (1) that secure the water pump.

**Tightening torque: 1 m.daN.**

- Connect the pump/cylinder cooling system hose (2).

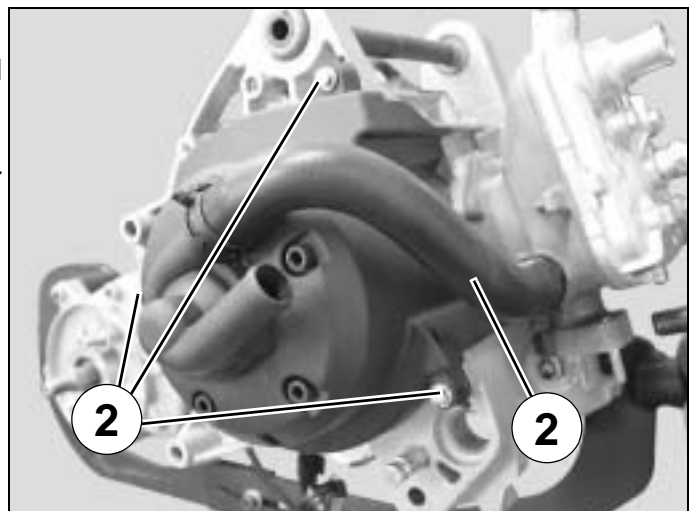

### ■ Fitting the air pump.

- Fit the air pump (1) with its 2 guiding bushes and a new O-ring slightly greased.
- Fit and tighten the 4 fixing bolts (2).

**Tightening torque: 0.7 m.daN.**

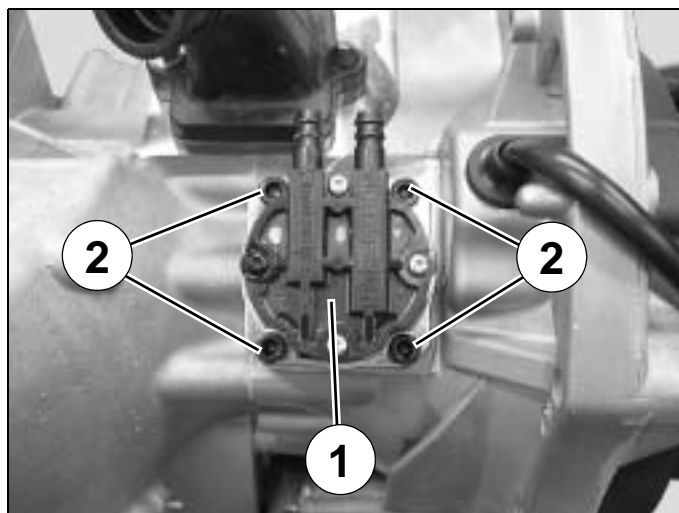

### ■ Fitting the starter motor dog.

- Fit the starter motor dog (1).
- Fit the starter ring (2) to the crank assembly and fit it to the splines.
- Fit washer 12x22x1 (3).
- Fit the bush and its fixing bolt (4).

**Tightening torque: 1 m.daN.**

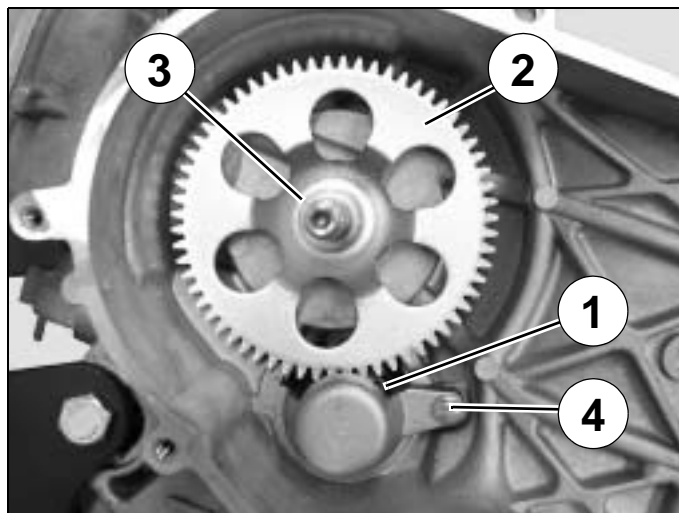

### ■ Fitting the drive pulley assembly.

- Fit the drive pulley with its guide hub (5) onto the crank assembly.
- Fit the belt (6) to the guide hub.
- Fit the fixed flange (7) to the crank assembly checking it is properly positioned on the crank assembly splines.
- Fit the washer (8) and the nut (9) and hand tighten.
- Hold the fixed flange with tool P/N 752237
- Tighten the nut.

**Tightening torque: 4 m.daN.**

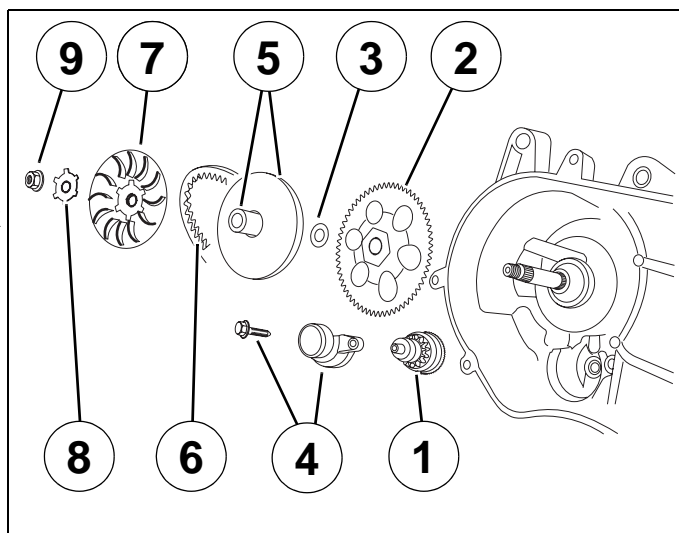

**Note: It is forbidden to use a power driver, this may upset the crank position.**

**Important: Precautions when refitting the drive pulley.**

**Certain parts of the drive pulley must not be discarded or cut down to a smaller size.**

**Any modifications may cause the nut to tighten against the crankshaft splines instead of the fixed flange and damage the crankshaft splines.**



## MISCELLANEOUS OPERATIONS

### ■ Removal of the starter system.

- Actuate the kick starter gear sector (1) by hand and remove the kick starter drive piece (2) and washer.

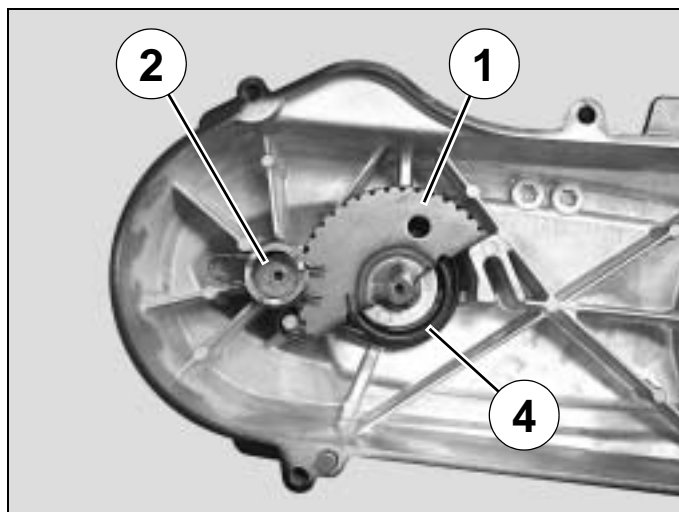

- Turn over the cover and remove the circlip (3) using snipe-nosed pliers P/N 69117.
- Remove the washer, the starter gear sector (1) and the spring (4) of the drive train cover.



### ■ Fitting the starter system.

- Fit the return spring (4), hook the longest buckle on the cover's pin (A).
- Fit the starter gear sector (1) into the lubricated bearing sleeve.
- Hook the second buckle (B) of the spring onto the starter gear sector.
- Wind the spring so as to position the kick starter sector on the stop (C) of the cover.
- Turn over the cover, fit the washer and the circlip on the the gear sector spindle.
- Fit the washer (5) on the housing of the kick starter drive piece.
- Wind approximately 1/8th of a turn the gear sector so as to place the kick starter drive piece (2).
- Position the pin (6) of the kick starter drive piece around the boss (D) of the housing.

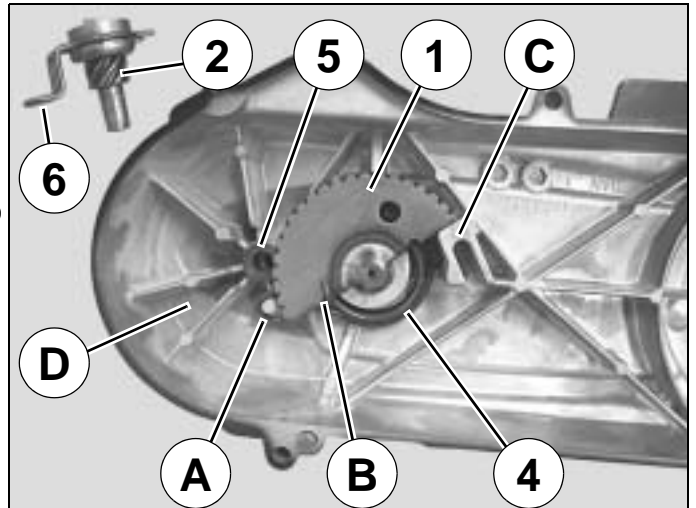

### ■ Changing the drive pulley bearings.

- Remove the transmission cover 6 fixing bolts.
- Remove the cover and the strut rubber bump-stop.
- Lock the fixed flange (1) with tool P/N 752237.
- Remove the nut (2) and washer (3) from the fixed flange.
- Remove the fixed flange.
- Remove the belt (4).
- Remove the guide hub and the drive pulley (5).
- Check that the washer is fitted and its condition (12x22x1) (6).

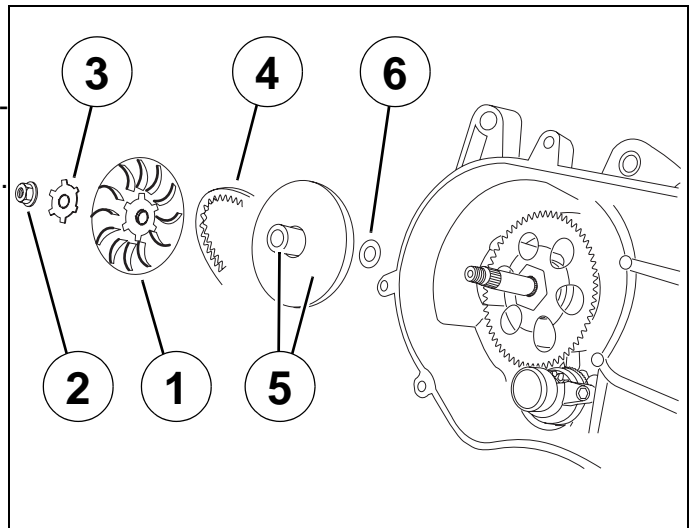

- Remove the 3 screws (7) that secure the bump-stop (8).
- Remove the bump-stop.
- Remove the ramp (9) and its 3 guides (10).
- Remove the moving flange (12) 6 bearings (11).

**The bearings must be changed if they show major signs of wear.**

**Reassembly:**

- Proceed in reverse order to disassembly and do not grease the bearings.
- Grease the moving flange bore lightly (high temperature grease).

**Note: Do not over-grease to avoid splashing the belt.**

**Tightening torque: 4 m.daN.**

**■ Removal of the clutch lining assembly.**

- Remove the transmission cover 6 fixing bolts.
- Remove the cover.
- Lock the clutch drum with the pin wrench P/N 752237.
- Remove the nut.
- Clamp the 2 strands of the belt to lower it between the flanges.
- Remove the clutch drum, the clutch drive pulley and driven pulley assembly and belt.
- Compress the clutch drive pulley and driven pulley assembly with the tool P/N 752127 clamped in the jaws of a vice.
- Remove nut (1) using spanner P/N 756725.
- Slacken tool P/N 752127.

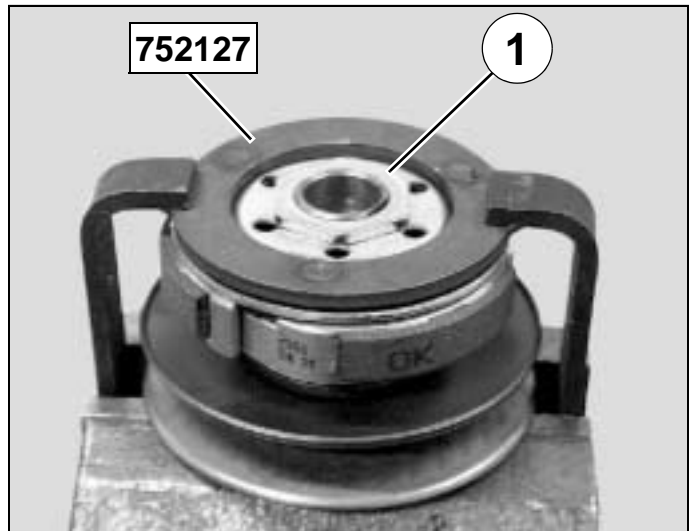
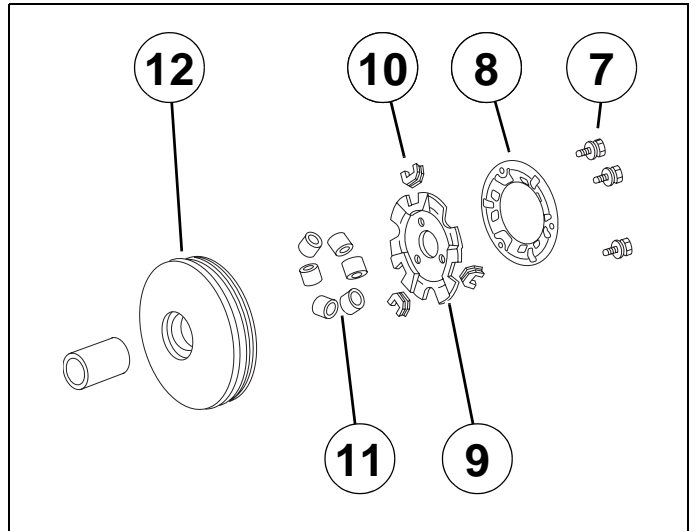



- Remove the clutch linings (2), the upper centring sleeve (3), the spring (4), and the lower centring sleeve (5).
- Remove the 3 pins (6) from the variable speed drive seat.
- Separate the fixed (7) and rotating (8) flanges.

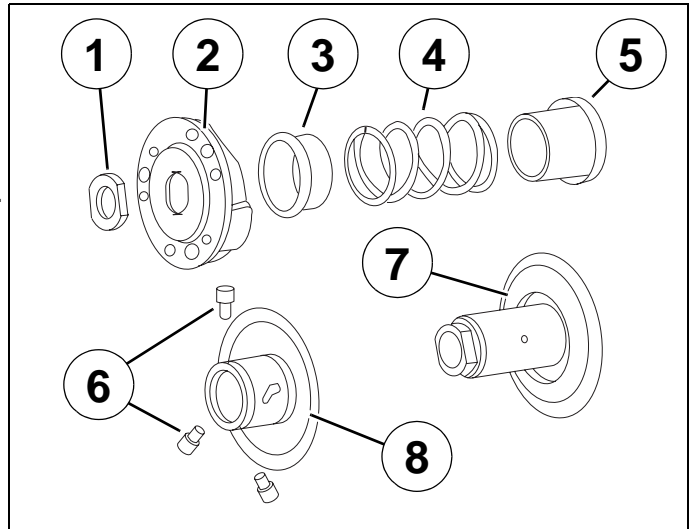

#### ■ Refitting the clutch lining assembly.

- After checking the 2 lip seals (9) and the 2 O-rings (10) of the rotating flange (8) are in good condition, grease the governor seat 3 pins (6) (high temperature grease) and assemble the parts in reverse order to removal.
- Compress the clutch drive pulley and driven pulley assembly with the tool P/N 752127.
- Tighten the nut (1).

**Tightening torque: 4.5 m.daN.**

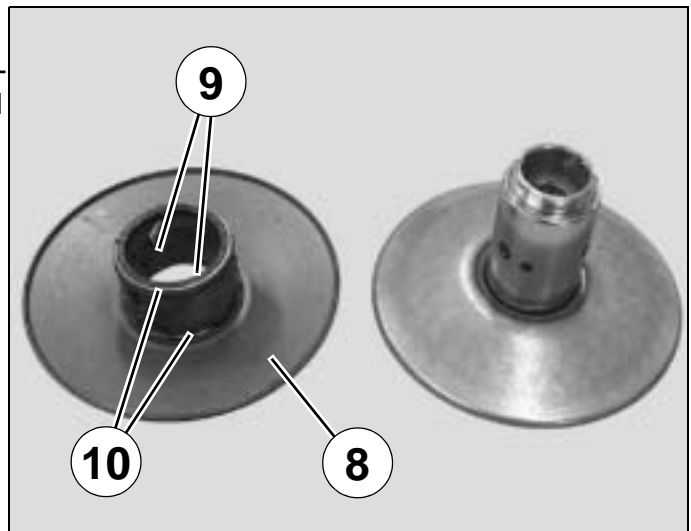

**Note: Before fitting the clutch drive pulley and driven pulley to the input shaft, fit the belt into the pulley bottom by opening the flanges by hand.**

- Fit the clutch drive pulley and driven pulley assembly.
- Fit the clutch cover.
- Fit and tighten the nut.

**Tightening torque: 4.5 m.daN.**

- Fit the transmission cover and the stand bump-stop.
- Fit and tighten the cover 6 fixing bolts.

**Tightening torque: 1 m.daN.**



■ **Removal of the carburettor.**

- Unclip the click-type collar that holds the intake silencer.
- Remove the air filter.
- Unclip the collar from the intake fitting.
- Disconnect:
  - The fuel supply hose (1).
  - The oil supply hose (2).
  - The vacuum pressure hose (depending on the model).
- Disconnect the electric choke.
- Remove the screw that secures the carburettor chamber cap (3).
- Remove the carburettor and its cap and needle valve.

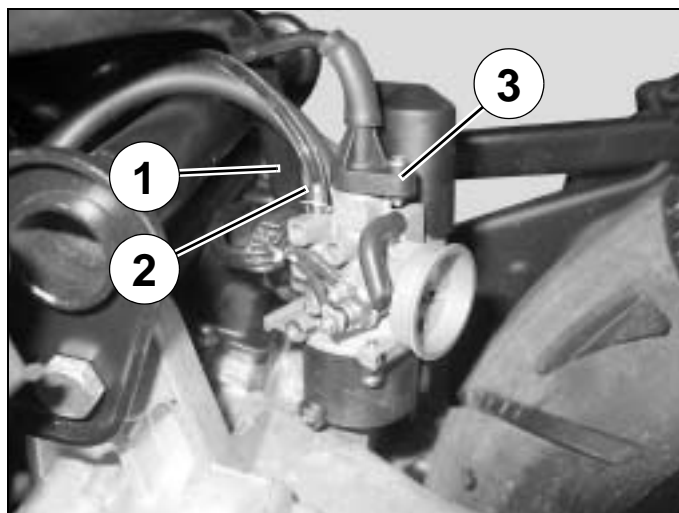

■ **Removal of the throttle valve.**

- Take out the throttle control cable (1) by compressing the spring using the throttle valve (2).
- Dismantle the valve equipped with its needle, spring and carburettor chamber cap.

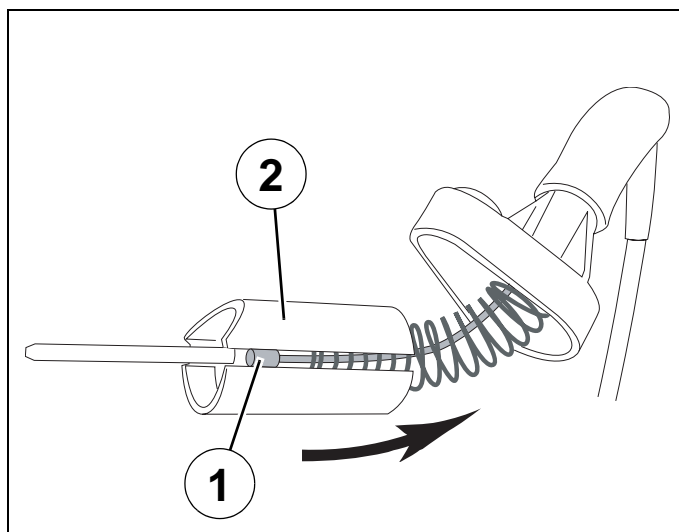

- Dismantle the needle (3) by pushing it out in order to remove the clips (4).

**Note: The height of the needle is factory set and cannot be modified.**

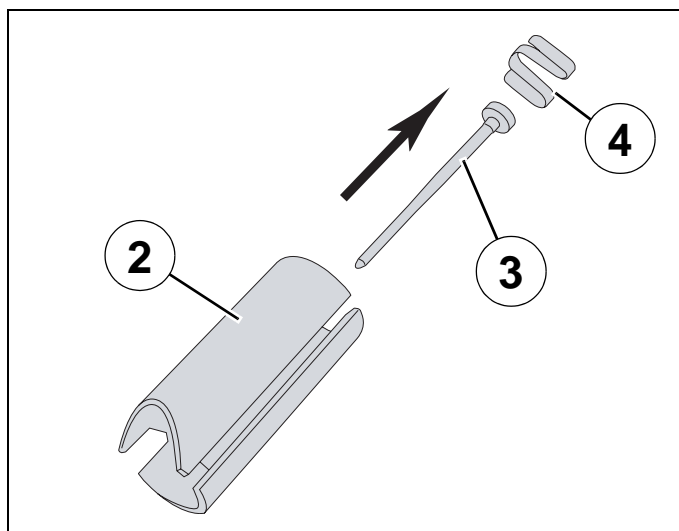

### ■ Removal of the electric choke.

- Remove the choke cap.
- Remove the 2 screws that secure the holder plate (1).
- Locate the position of the choke (2) and then remove it.

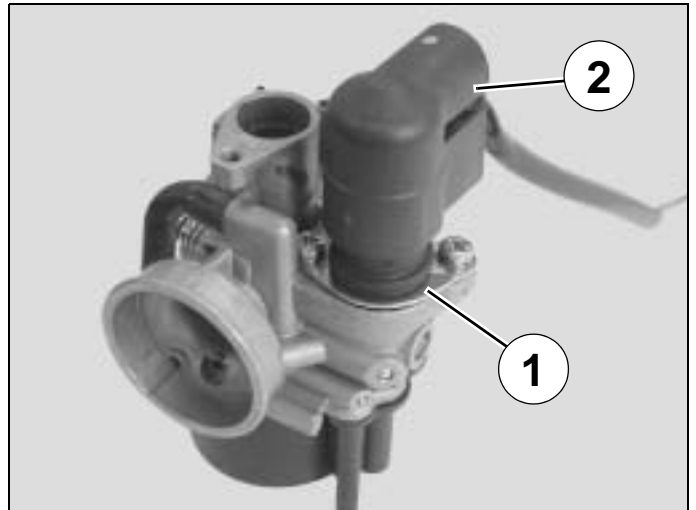

### ■ Removal of the float, needle valve and jets.

- Remove the 2 screws that secure the float chamber (1).
- Remove the chamber.

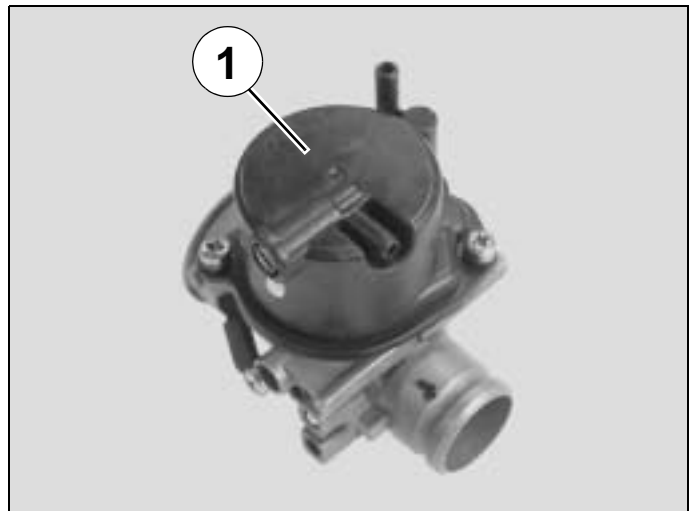

- Remove the O-ring (2).
- Loosen the float pin clamping screw (3).
- Remove the float (4) with its pin and needle valve.

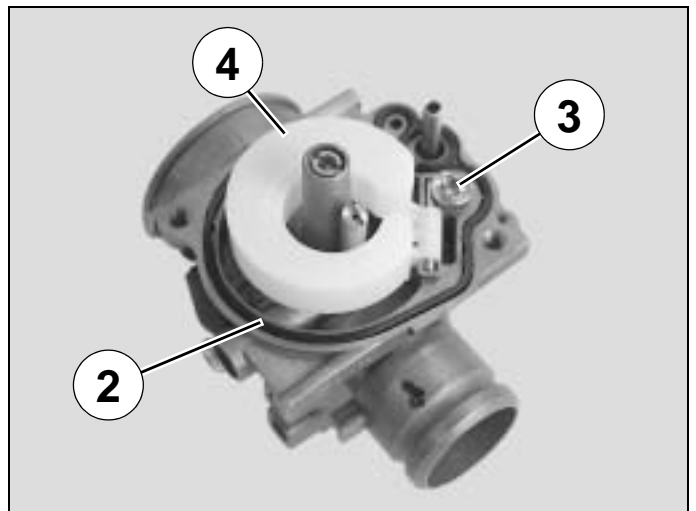

- Remove the idle jet (5).
- Remove the main jet (6).
- Remove the jet spray nozzle (7).

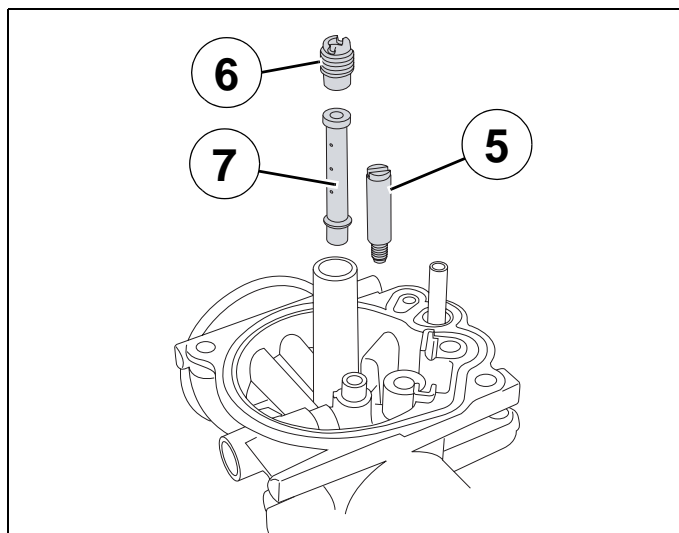

- Check the condition of the needle valve and the needle valve seat (A).
- Check the condition of the float chamber O-ring.

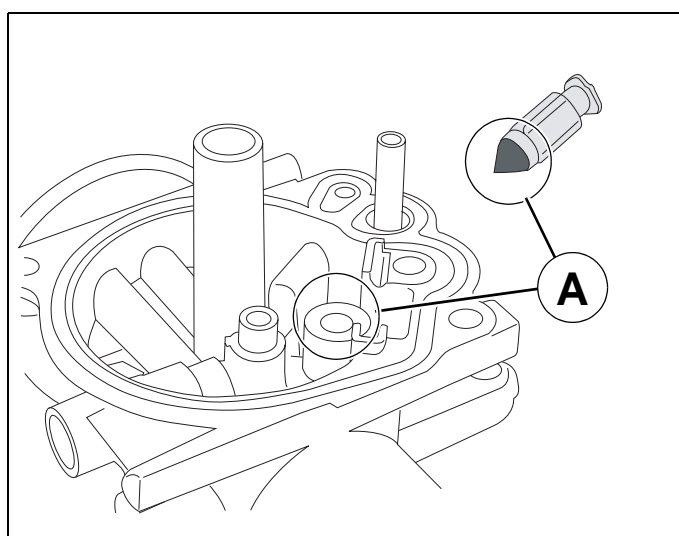

**■ Removal of the engine speed adjuster screw and mixture control screw**

- Turn clockwise the engine speed adjuster screw (1) and mixture control screw (2) while counting the number of turns until they are screwed home
- When re-fitting, this operation allows you to put them back to their initial adjustment position

**Note: Do not turn the screws home forcefully**

- Remove the idle screw and the mixture control screw with their spring.

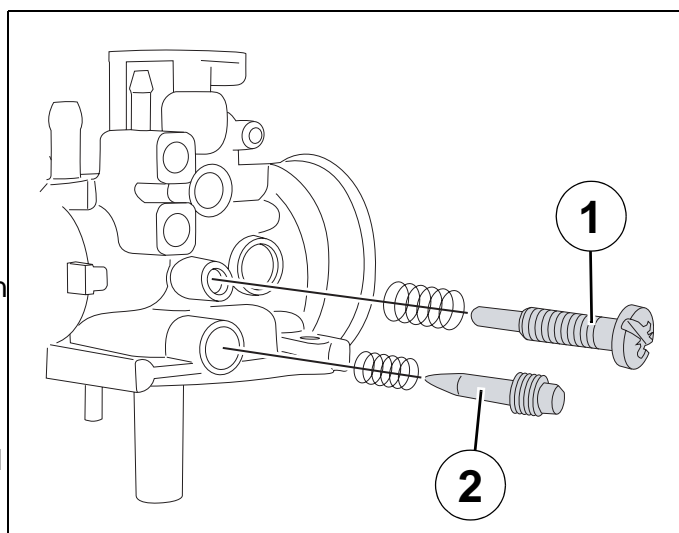

- Clean the carburettor body and its components with a cleanser Biosane P/N 754748.
- Blow into every jet and duct of the carburettor body with compressed air.

**Note: Do not use any metal tool which can damage the ducts of these items.**

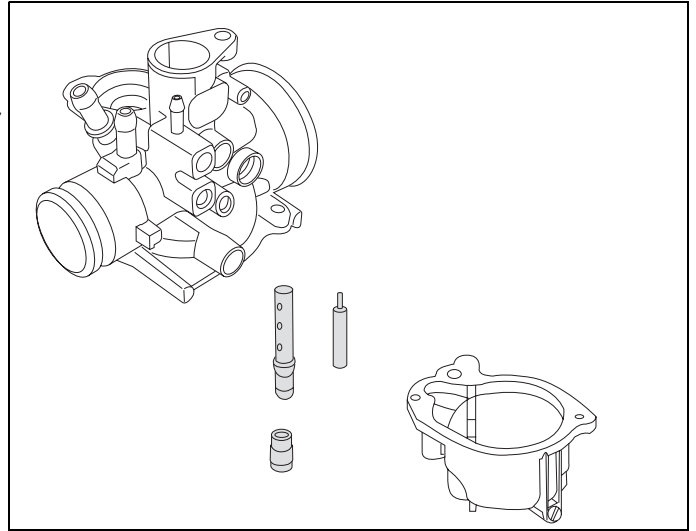

**REFITTING SPECIFIC COMPONENTS****■ Re-fitting the jets, float and needle valve.**

- Fit the jet spray nozzle (1).
- Fit the main jet (2).
- Fit the idle adjuster screw (3).

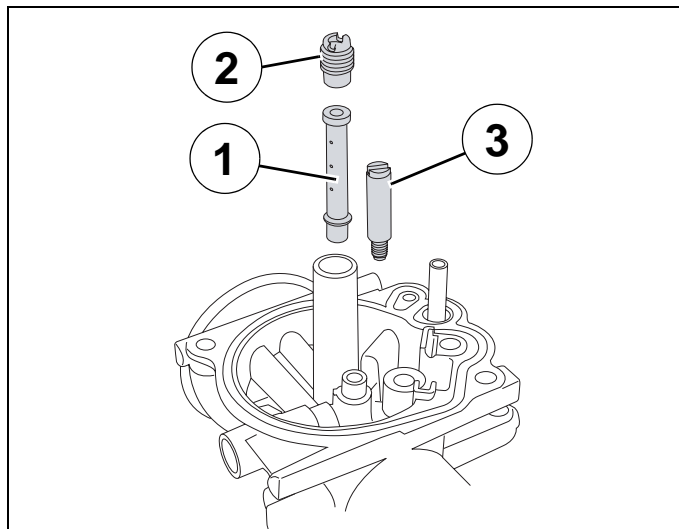

- Place the needle valve (4) in the grooves of the float (5).
- Fit the pin (6) into the float.
- Install the float on the carburettor body while fitting the needle valve into its recess.

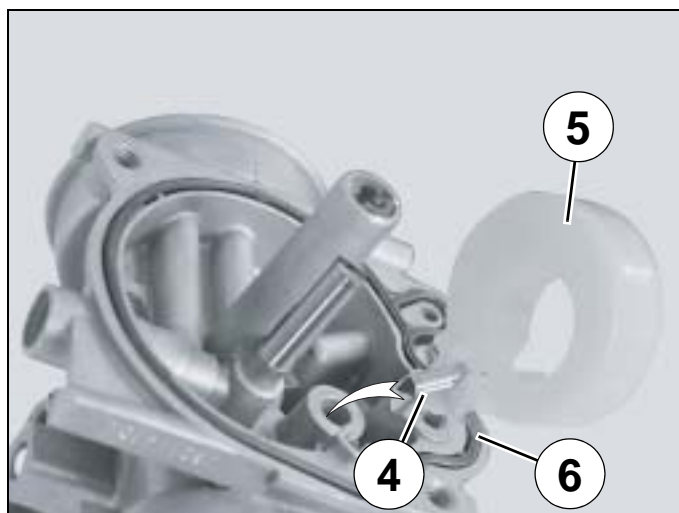

- Position the pin in its recess.
- Fit and tighten the screw (7) that secures the float pin.
- Fit the O-ring (8).
- Fit the float chamber.
- Fit and tighten the 2 screws of the float chamber.

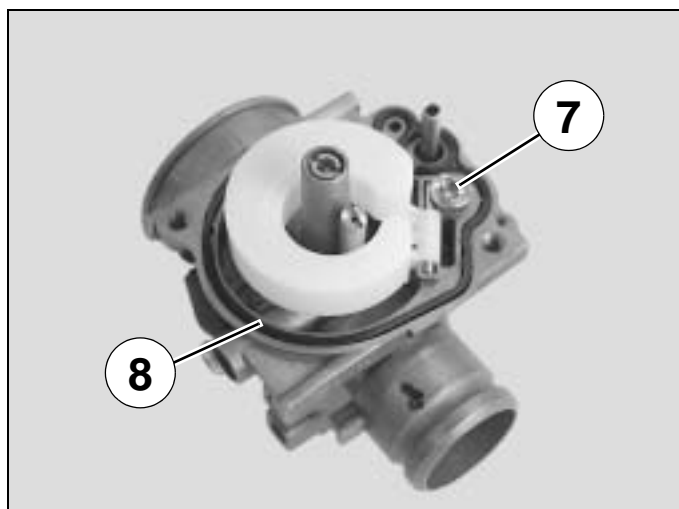

- Re-install all the other components and, if necessary, when starting the engine, readjust according to the values indicated on the technical data card.

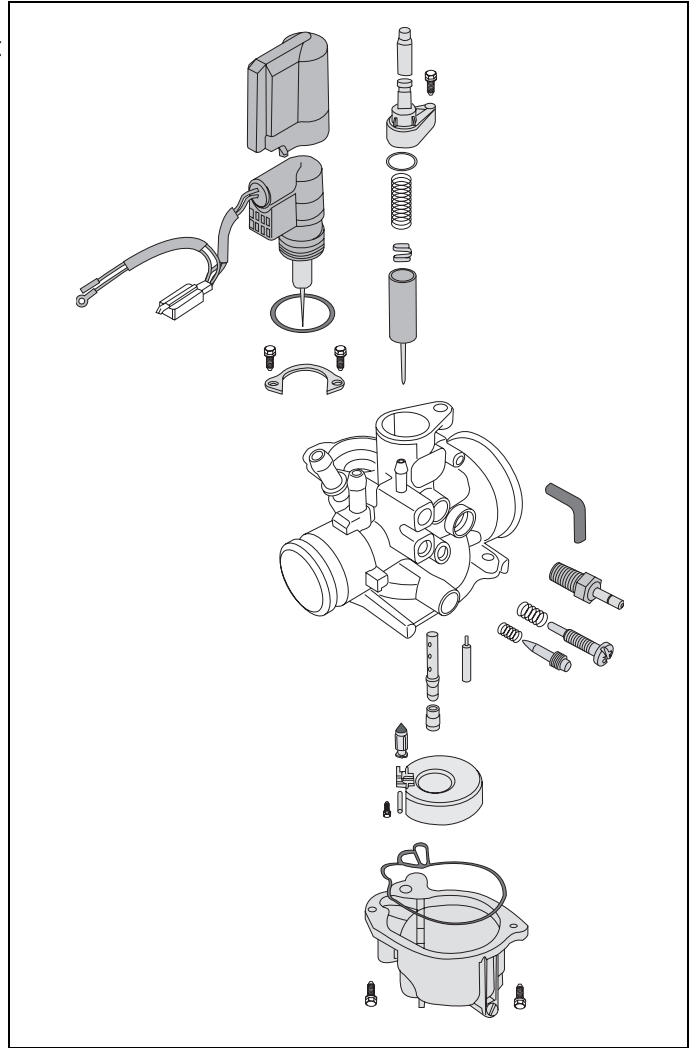



P/N 758026

*In our permanent concern to make improvements PEUGEOT MOTOCYCLES reserves the right to suppress, modify, or add any reference mentioned.*

*DC/APV Printed in the E.U. 02/2005 (non contractual pictures)*

