



Sales division
Technical network leadership

WORKSHOP MANUAL



**50 CC 4-STROKE ENGINE
2 VALVES
AIR COOLING**



TABLE OF CONTENTS

TABLE OF CONTENTS	1
CHARACTERISTICS	3
Capacities.....	3
SPECIAL IMPORTANT POINTS	4
Oil and fuel	4
TIGHTENING TORQUE	5
SPECIAL TOOLS	6
DISASSEMBLY	7
Putting the engine on the stand.....	7
Removal of the primary transmission cover.....	7
Removal of the drive pulley.....	8
Removal of the driven pulley.....	8
Removal of the intake pipe.	9
Removal of the cooling volutes.....	9
Removal of the rocker cover.	10
Removal of the pulsair.	10
Removal of the rotor.	11
Removal of the winding and pick-up.....	12
Removal of the cylinder head.	13
Removal of the rockers.....	14
Removal of the valves or valve stem seals.....	15
Removal of the cylinder.	16
Removal of the piston.....	17
Removal of the ignition casing.....	17
Removal of the oil pump.....	18
Removal of the RH crankcase half.	19
Removal of the crankshaft.....	19
Checking the crankshaft and conrod assembly.	19
Removal of the secondary transmission cover.....	20
REFITTING SPECIFIC COMPONENTS	22
Assembly of the engine casings.....	22
Installing the ignition casing.	23
Installing the piston rings on the piston.	24
Fitting the piston.	24



Fitting the cylinder.	25
Fitting the cylinder head.	25
Setting the timing.	26
Installing the valve clearance.	27
Checking the valve clearance.	28
Installing the winding and the pick-up.	28
MISCELLANEOUS OPERATIONS	30
Removal of the starter system.	30
Fitting the starter system.	31
Changing the drive pulley bearings.	31
Fitting the drive pulley assembly.	32
Removal of the clutch lining assembly.	33
Refitting the clutch lining assembly.	34
Removal of the choke.	35
Removal of the throttle valve.	35
Removal of the float, needle valve and jets.	36
Removal of the engine speed adjuster screw and mixture control screw.	37



CHARACTERISTICS

	50 cc
Marking	*
Type	4-stroke single-cylinder 2 valves per cylinder with chain driven overhead camshaft
Cooling	Air
Bore x stroke	39 x 41,4 mm
Cubic capacity	49,58 cc
Max. power output	2 kW at 7000 rpm
Max. torque rating	6000 rpm
Lubrication	Trochoidal pump
Transmission	By 2 variable pulleys and V-type belt
Clutch	Centrifugal automatic
Exhaust	Catalytic
Starter motor	*
Spark plug	NGK CR 7HSA
Magneto flywheel	*
Fuel supply	Carburetion

■ Capacities

Engine oil	0.80 l SAE 5W40 Minimum grade: API SJ
Relay box oil	0.12 SAE 80W90

* Not completed



SPECIAL IMPORTANT POINTS

■ Oil and fuel



**This engine is designed to run on 95 or 98 unleaded fuel only.
Never run the machine with a petrol/oil mixture.**



The fuel pipes must be changed if they show signs of wear, cracks, etc.



Petrol is highly inflammable, do not smoke in the working area and avoid proximity to flames or sparks.



TIGHTENING TORQUE

Cylinder head	1.8 m.daN
Cylinder casings	1 m.daN
Transmission cover	1 m.daN
RH casing cover	1 m.daN
Automatic tensioner	0.8/1 m.daN
Starter motor	1 m.daN
Rotor	5 m.daN
Stator	0.8 m.daN
Engine speed sensor	0.6 m.daN
Drive pulley	5 m.daN
Driven pulley	5 m.daN
Spark plug	1.8 m.daN
Inlet manifold	1 m.daN

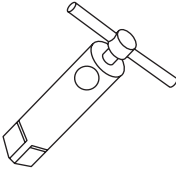
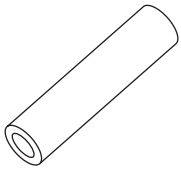
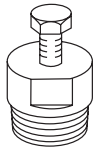
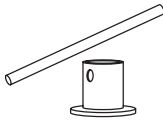
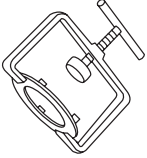
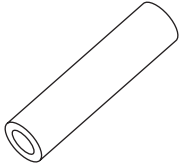
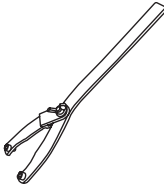
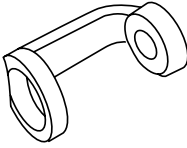
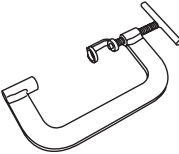
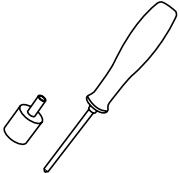
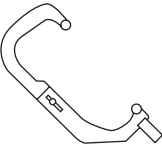
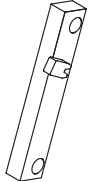

SPECIAL TOOLS

	Tool N°	Designation	Used with		Tool N°	Designation	Used with
	64765	Engine mount	755982		756668	Lip seal push tool	
	750806	Flywheel puller			756725	8 mm pipe wrench	752127
	752127	Clutch compression tool			757990	Lip seal push tool	
	752237	Adjustable pin wrench			758595	Valve spring lifter adapter	754035
	754035	Valve lifter	758595		758596	Valve stem seal drift	
	755982	Engine mount adapter	64765		759467 (*)	Fixed flange locking tool	

(*) New or modified tool



DISASSEMBLY**■ Putting the engine on the stand.**

- Fit the engine to adapter P/N 755982.
- Put the assembly on stand P/N 64765 clamped in the jaws of a vice.

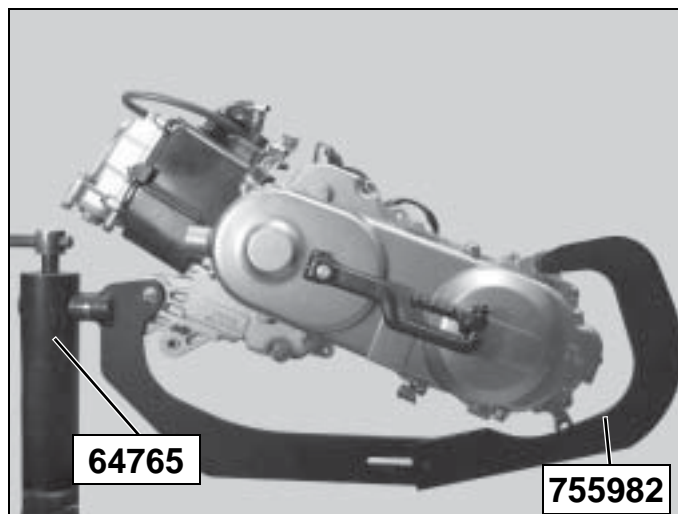

- Remove the engine's oil filler cap (1).
- Empty the oil from the engine (2).

Note: Every time oil is changed, the filter (3) must be cleaned and the O-ring changed.

Tightening torque: 4 m.daN.

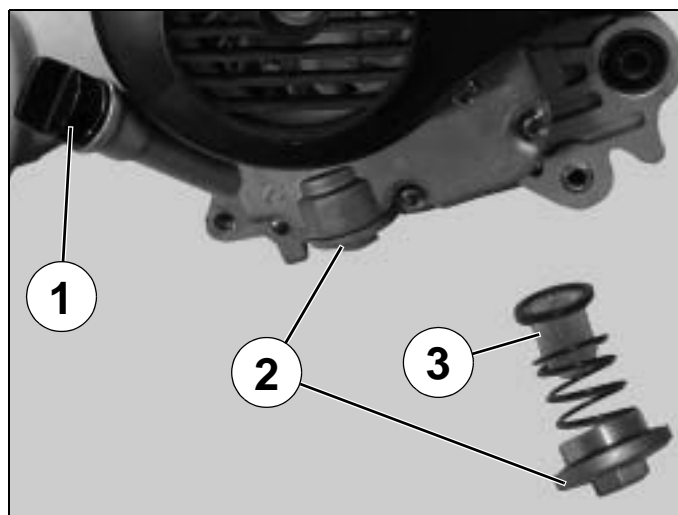
**■ Removal of the primary transmission cover.**

- Remove the 8 bolts that secure the cover.
- Remove the transmission cover.
- Removal of the gasket.
- Remove the 2 centring pillars.

Tightening torque: 1 m.daN.

Note: Every time it is removed, change the gasket.

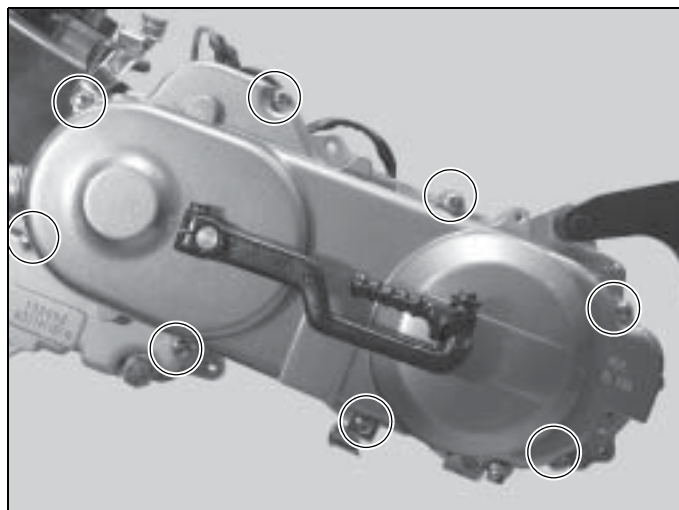

■ Removal of the drive pulley.

- Hold the fixed flange with tool P/N **759467**.
- Remove the nut (1) and washer (2) from the fixed flange.
- Remove the starter hub (3) and the turbine (4).
- Remove the fixed flange (5).

Tightening torque: 5 m.daN.

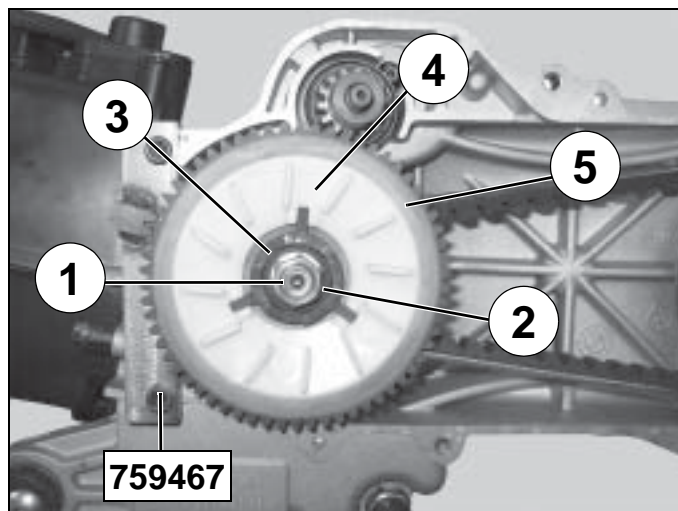

- Remove the belt.
- Remove the drive pulley (6) with the guide hub (7).
- Remove the washer (8).
- Remove the starter dog (9).

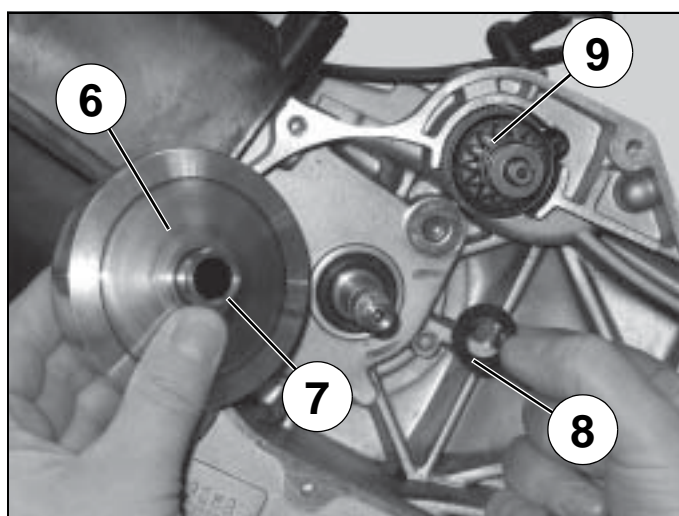

■ Removal of the driven pulley.

- Immobilize the clutch drum using the ajustable pin wrench P/N **752237** or the flywheel clamp P/N **68570**.
- Remove the nut (1).
- Remove the clutch drum and the clutch and drive pulley assembly.

Tightening torque: 5 m.daN.

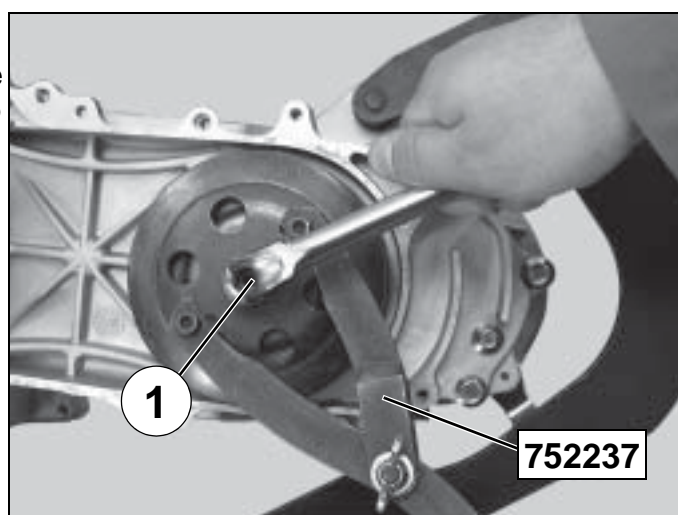

■ Removal of the starter motor.

- Remove the 2 fixing bolts (1).
- Remove the starter motor (2).

Tightening torque: 1 m.daN.

Note: Check the condition of the starter motor O-ring.

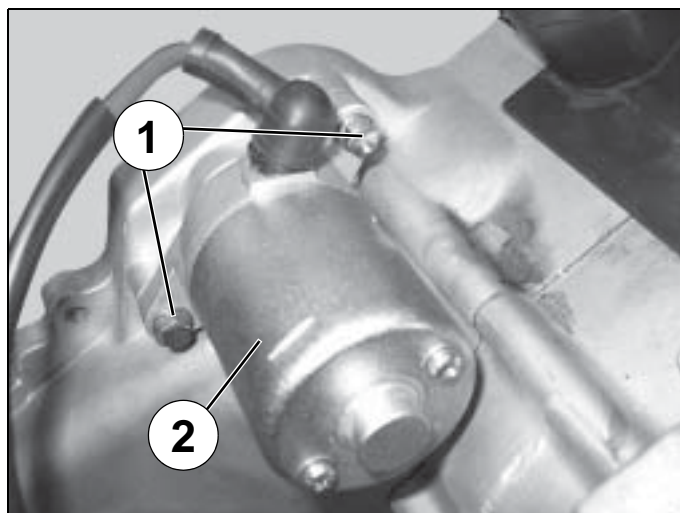

■ Removal of the intake pipe.

- Remove the 2 nuts that secure the intake pipe (1).
- Remove the intake pipe and its plastic spacer.
- Remove the 2 O-rings.

Tightening torque: 1 m.daN.

Note: Change the O-rings if necessary.

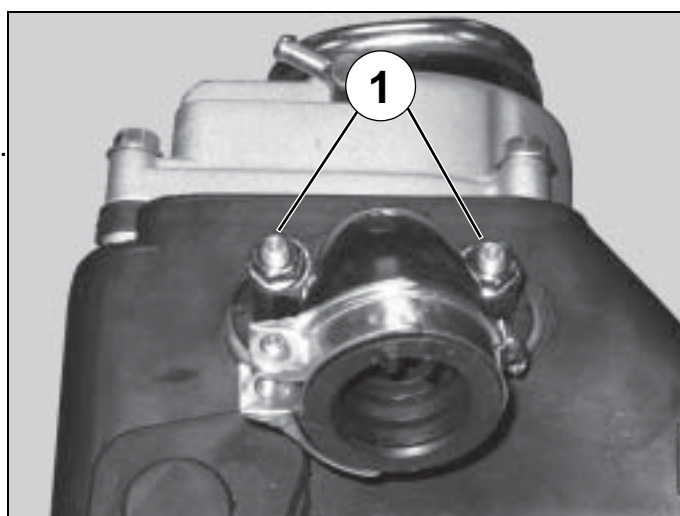

■ Removal of the cooling volutes.

- Remove the 4 screws (1) that secure the volute on the flywheel magneto side.
- Remove the volute (2).
- Remove the fastening screw (3).

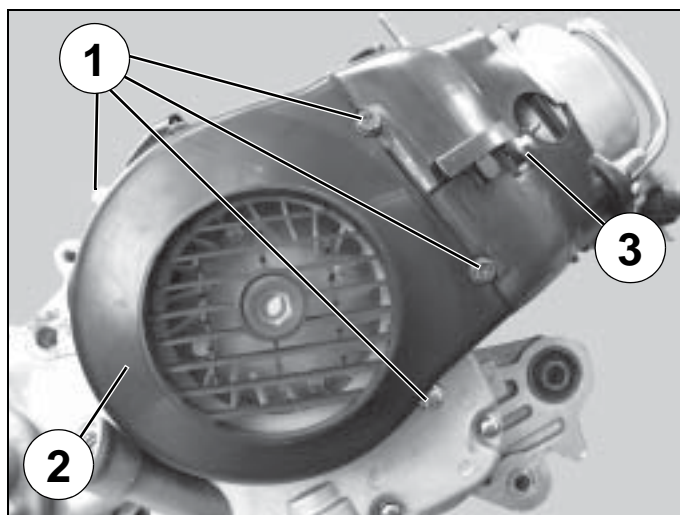

- Remove the 2 screws (4) that secure the volute on the clutch side.
- Remove the cooling volutes.
- Remove the air seal (5).

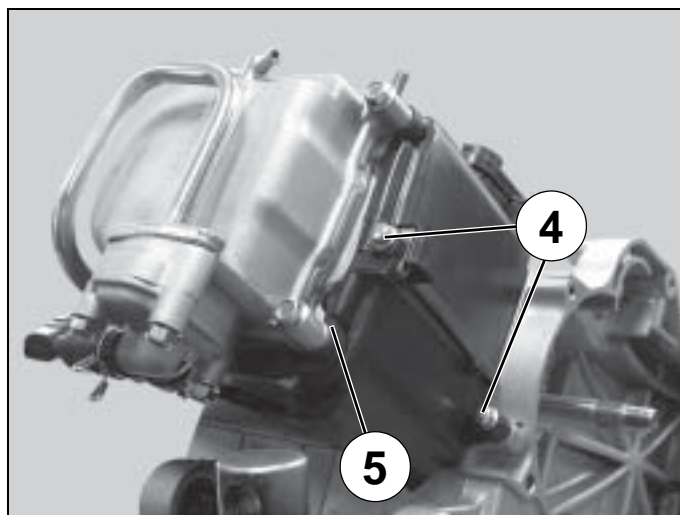

■ **Removal of the rocker cover.**

- Remove the 4 fixing bolts (1).
- Remove the 2 screws that secure the pulsair pipe (2).
- Remove the cylinder head cover equipped with its rubber gasket.

Tightening torque: 1 m.daN.

Note: The O-ring must be changed every time it is removed.

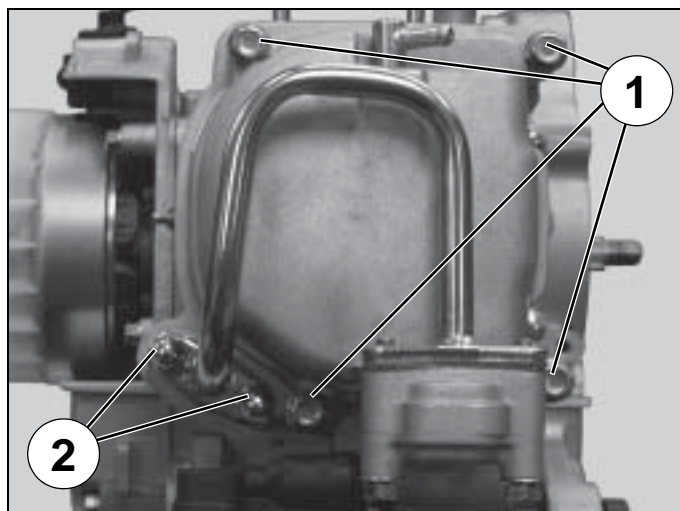

■ **Removal of the pulsair.**

- Remove the pulsair filter.
- Remove the 2 bolts (1).
- Remove the screw (2).
- Remove the pulsair cover (3).
- Remove the flap valve (4).

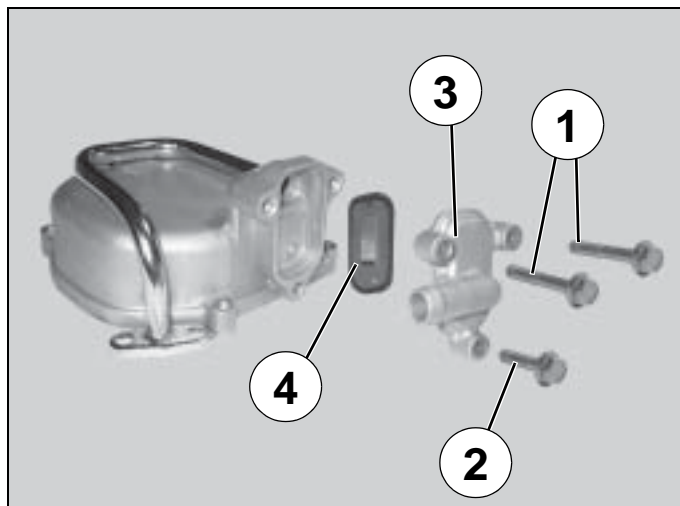

■ Removal of the rotor.

- Remove the 4 screws (1) that secure the turbine.
- Remove the turbine.

Tightening torque: 1 m.daN.

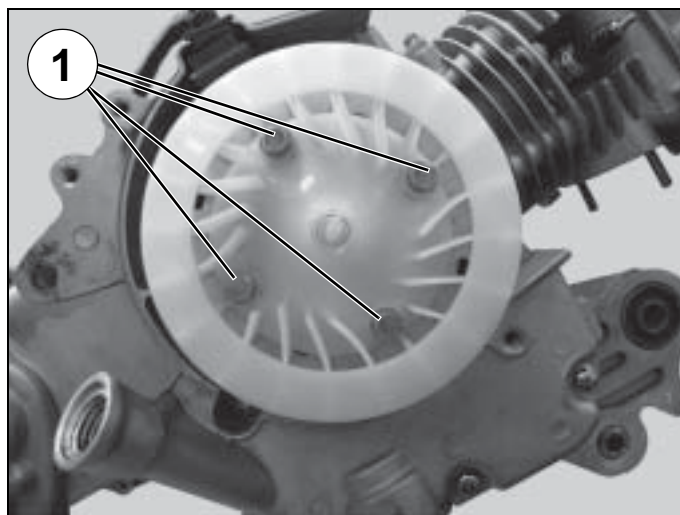

- Lock the rotor with the adjustable pin wrench P/N 752237.
- Remove the nut (1).

Tightening torque: 5 m.daN.

Important: Using an inappropriate tool can damage the windings of the flywheel magneto.

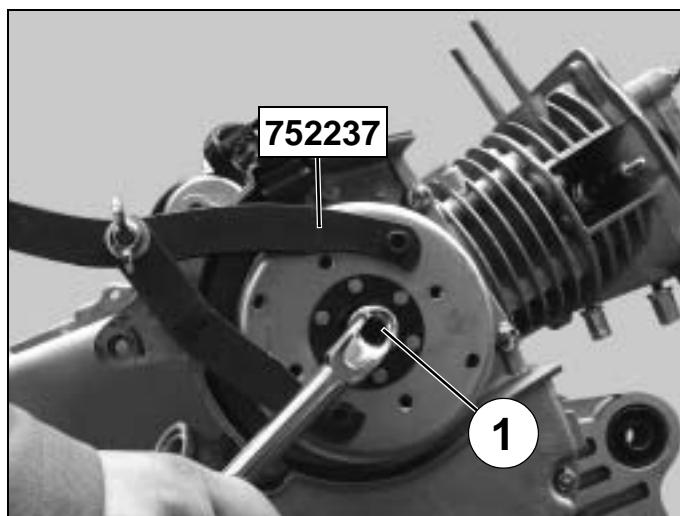

- Tighten flywheel extractor P/N 750806 on the rotor (2).
- Lock the flywheel extractor and turn the thrust bolt until the rotor is released.
- Remove the rotor.

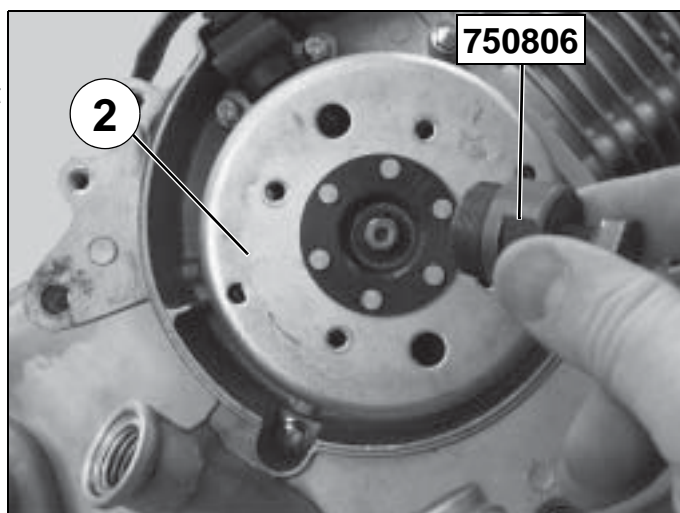

■ Removal of the winding and pick-up.

- Remove the 2 screws (1) that secure the pick-up and the 2 screws (2) that secure the stator assembly.
- Remove the stator and sensor assembly (3).

Tightening torque:

Screw (1): 0.6 m.daN.

Screw (2): 0.8 m.daN.

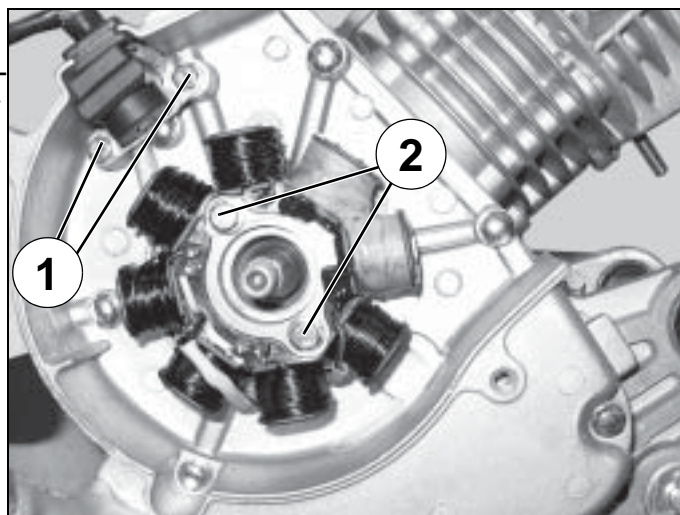

■ Removal of the chain tensioner.

- Remove the screw, the O-ring and the tensioner spring (1).
- Remove the 2 mounting screws (2) from the tensioner body.

Tightening torque:

Screw 1: 0.8 m.daN.

Screw 2: 1 m.daN.

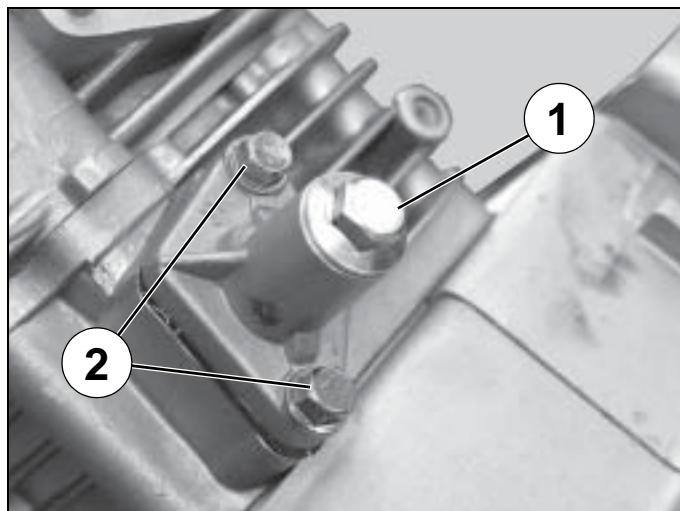

- Remove the chain tensioner and slacken it by pressing the ratchet tooth (A).
- Remove the paper gasket.

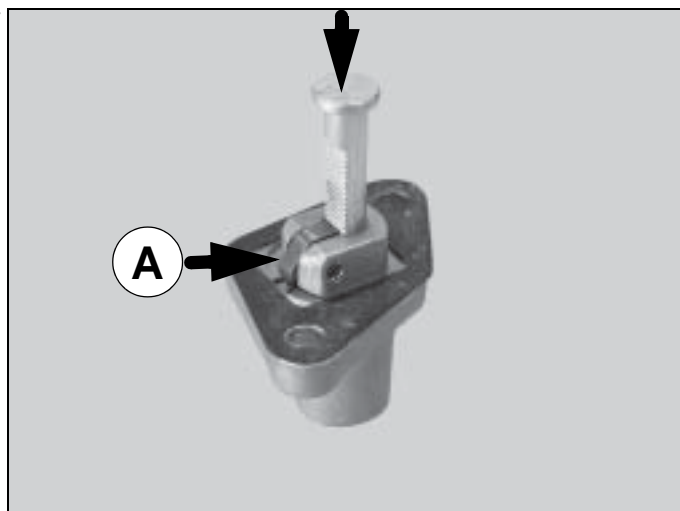

■ Removal of the cylinder head.

- Remove the spark plug.
- Rotate the engine manually in the direction of operation in order to bring the rocker pads over the cam lobes (A).

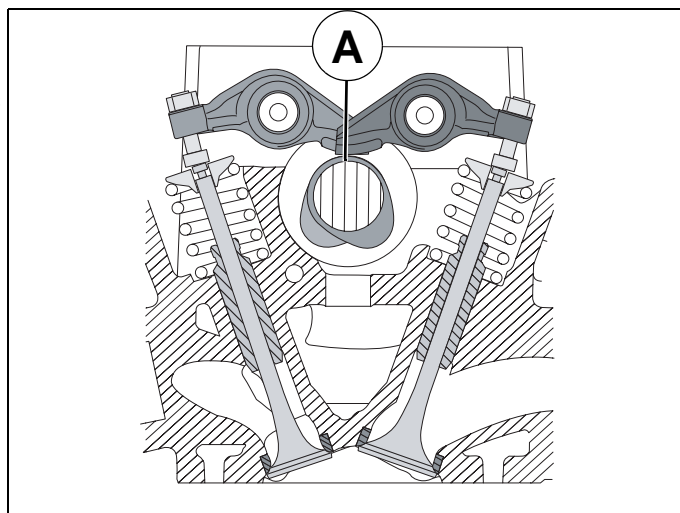

- Loosen the 2 washers screws (1).
- Gradually loosen in a crosswise order the 4 nuts which secure the cylinder head (2).
- Remove the 4 nuts and washers and the 2 washer screws.
- Remove the upper bearing from the camshaft (3).

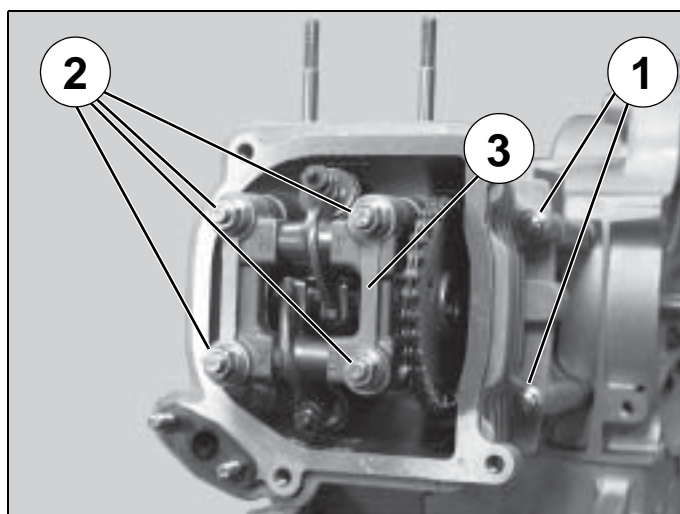

- Disengage the timing chain (4).
- Remove the camshaft (5).

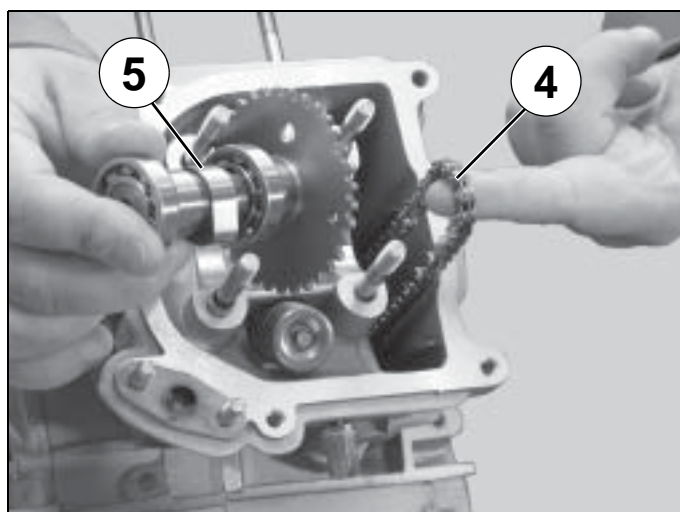

- Remove the cylinder head, the metal seals (6) and the 2 centring pillars (7).
- Remove the chain guide pad (8) (fitted in the cylinder on the exhaust side).

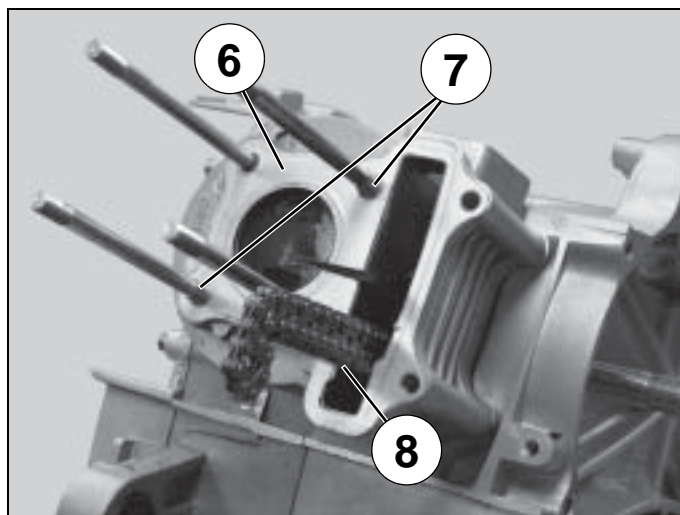

■ **Removal of the rockers.**

- Remove the 2 rocker shafts (1).
- Remove the inlet (2) and exhaust (3) rockers.

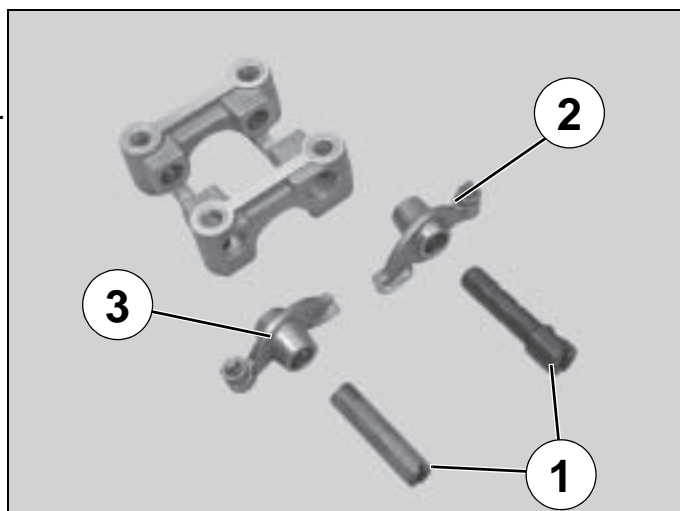

- When re-installing, the rocker pins shall be positioned in such a way that the upper half journal bearing can be fitted on the anchor pins.

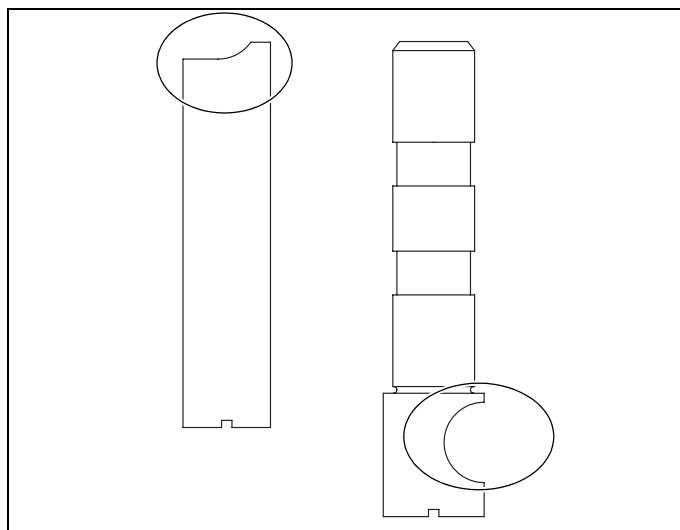

■ Removal of the valves or valve stem seals.

- Compress the spring of one of the valves using the valve lifter P/N **754035**.
- Remove the 2 half cones (1).
- Uncompress the spring and remove the tool.

Note: Use the valve lifter provided with adaptor P/N **758595**.

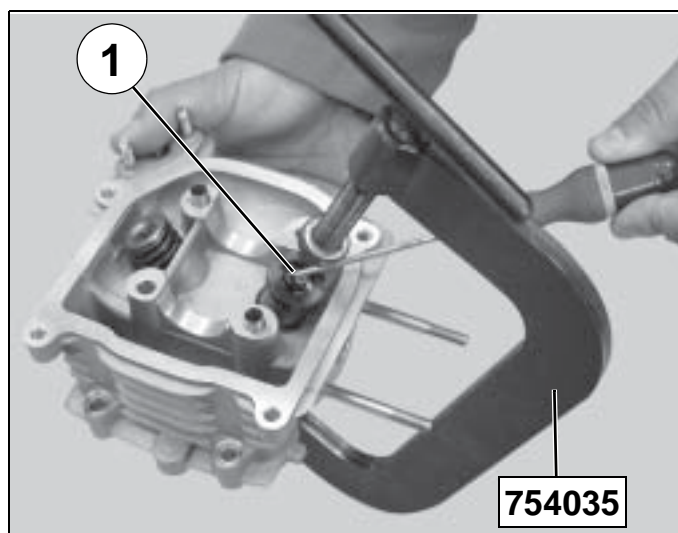

Remove:

- The upper cup (2).
- The springs (3).
- The lower washer (4).
- The valve (5).
- Remove the 2nd valve in the same way.

Note: When re-installing, fit the valve springs, the closest coils against the cylinder head.

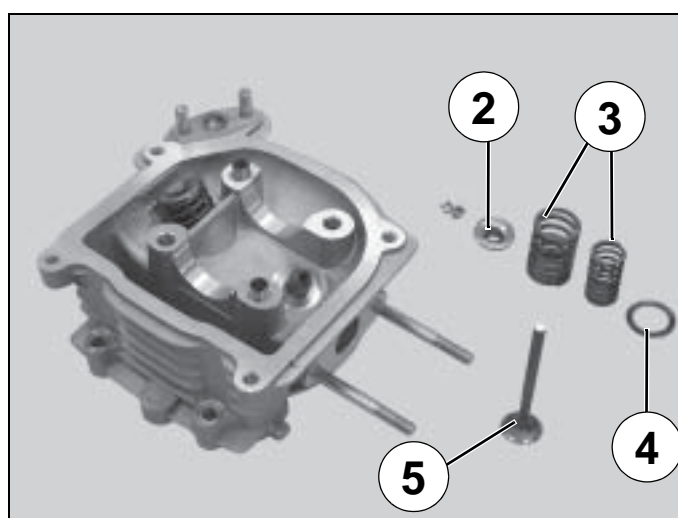

Note: When removing a valve, always change the valve stem seal.

- Using tool P/N **758596**, fit a new valve stem seal.

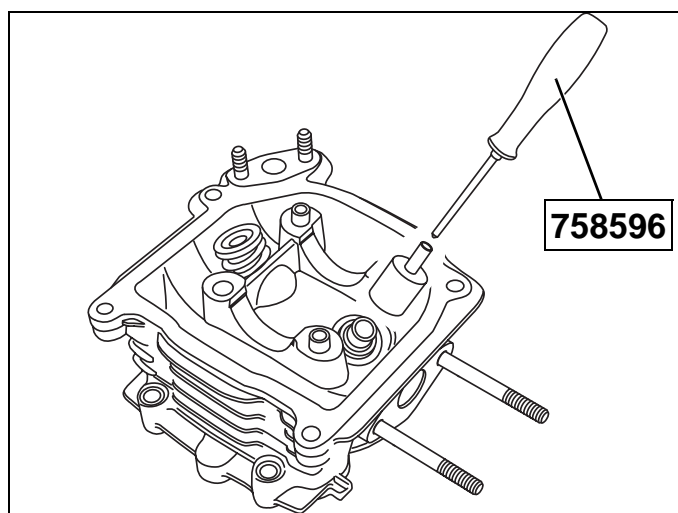

Note: When re-installing, lubricate the 2 half cones (6) so as to hold them in the groove of the valve's stem.

- Placing the 2 half cones (6) into the cup using the tool shall not be done forcefully when decompressing the spring (7).

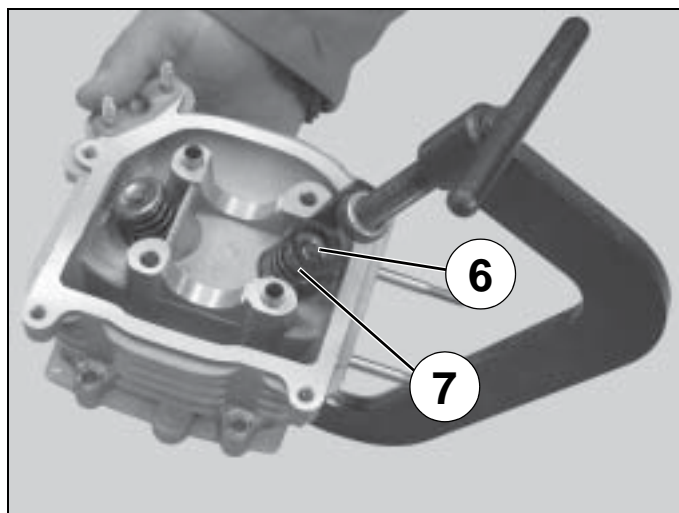

When re-installing, the camshaft bearings, the rocker shafts and the contact between the rockers and the valves shall well lubricated in order to avoid any risk of seizure when starting the engine (use a Molykote type grease). Seals and valve stems must be lubricated.

■ Removal of the cylinder.

- Remove the cylinder (1).
- Remove the base gasket (2) and the 2 centring pillars (3).
- Remove the screw which secures (4) the chain tensioner slipper (5) (check the condition of the O-ring and change it if necessary).
- Remove the chain tensioner slipper.

Tightening torque: 1 m.daN.

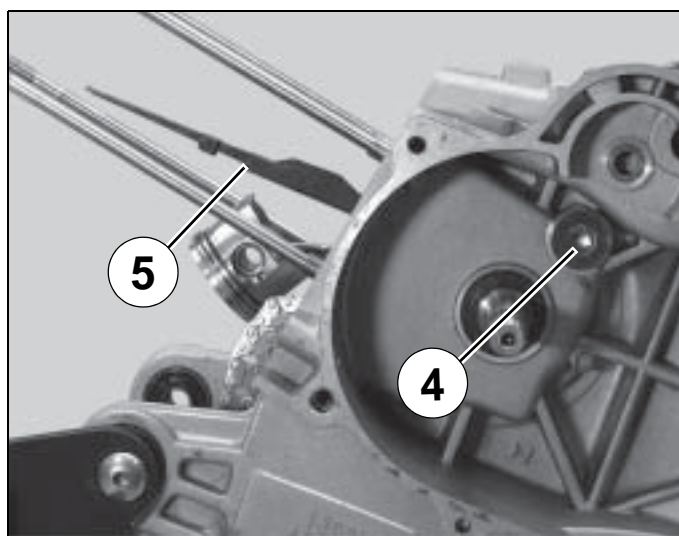
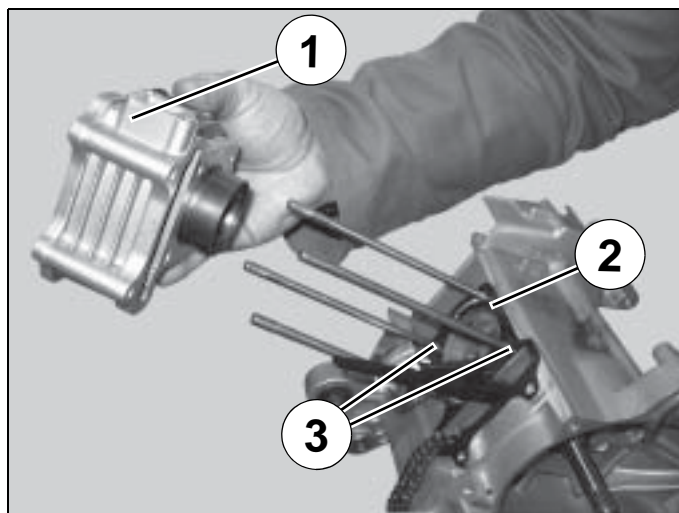

■ Removal of the piston.

- Remove one of the circlips (1) with pliers.
- Remove the gudgeon pin.
- Remove the piston (2).

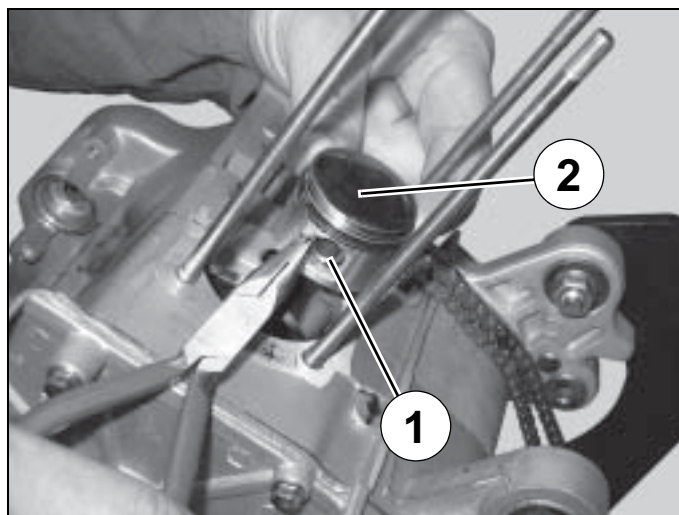

■ Removal of the ignition casing.

- Remove the 4 fixing bolts (1) (85 mm).
- Remove the 4 fixing bolts (2) (100 mm).

Note: No tools are necessary for removing the ignition casing.

Tightening torque: 1 m.daN.

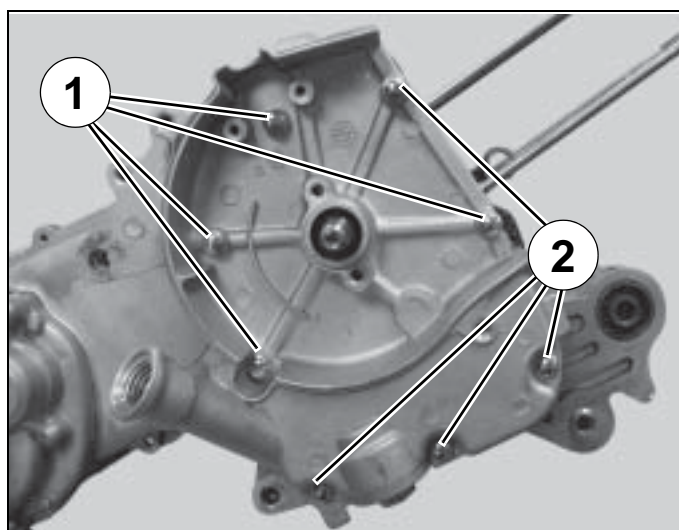

- Remove the ignition casing (3).
- Remove the 2 centring pillars (4) and the paper gasket (5).

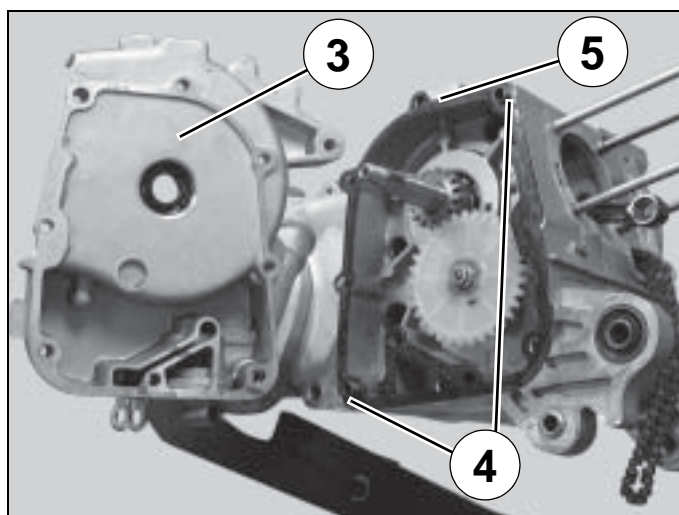

■ Removal of the oil pump.

- Hold the conrod and crankshaft assembly by means of the fixed flange.
- Remove the nut that secures the plastic sprocket (1).
- Remove the plastic sprocket (2).

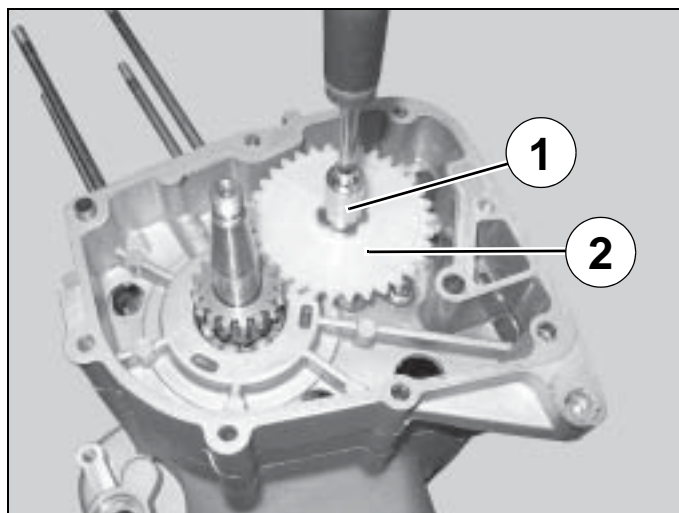

- Remove the 3 screws which secure the oil pump (3).
- Remove the oil pump.

Tightening torque: 1 m.daN.

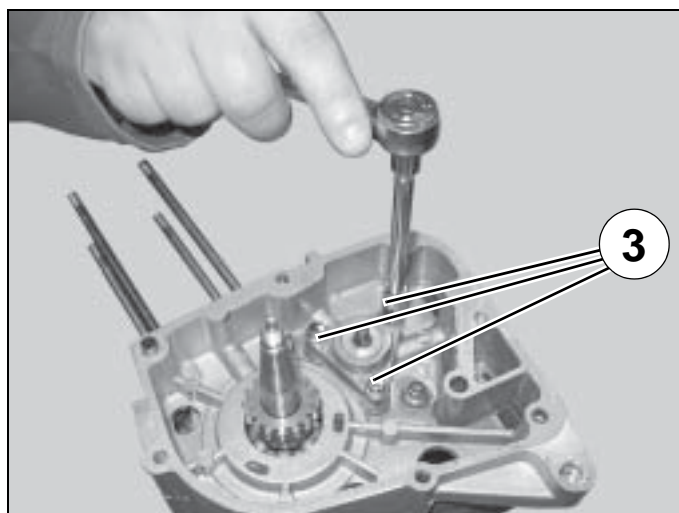

Note: When removing the oil pump, always change the 2 O-rings (3).

Note: Before re-assembling, lubricate the oil pump by dipping it into a pan containing clean motor oil.

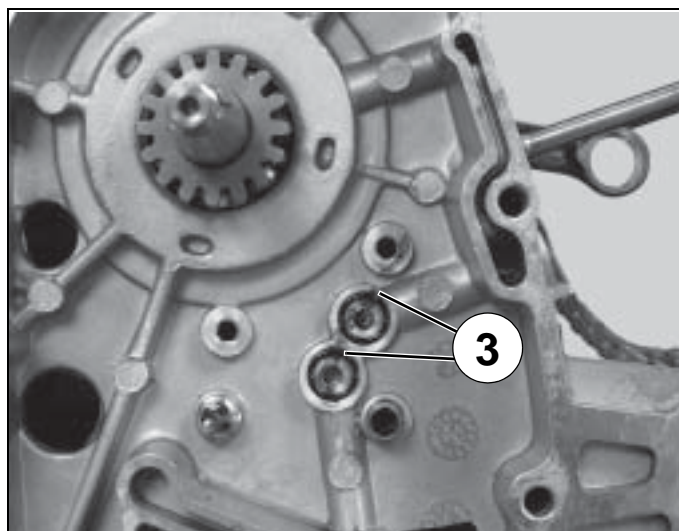

■ Removal of the RH crankcase half.

- Remove the 2 O-rings (1).
- Remove the centring pillar of the oil pump (2).
- Remove the fastening screw (3).
- Remove the RH casing (4).
- Remove the 2 centring pillars.
- Removal of the gasket.

Tightening torque: 1 m.daN.

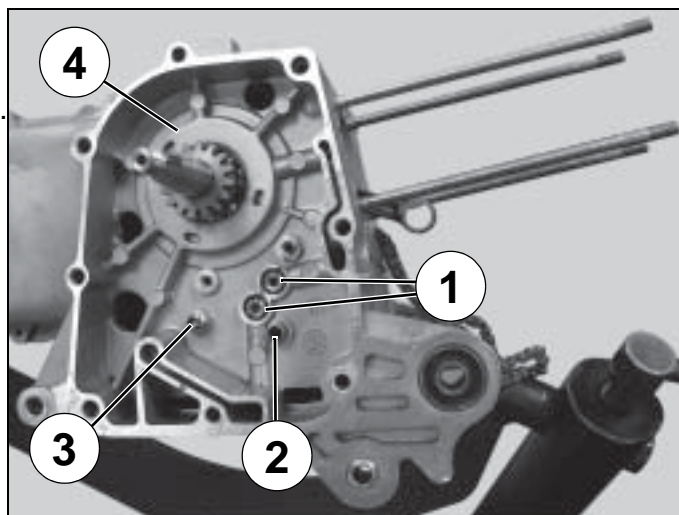

■ Removal of the crankshaft.

- Removing the the cranshaft and conrod assembly (1).
- Remove the timing chain and notice its direction of rotation (2).

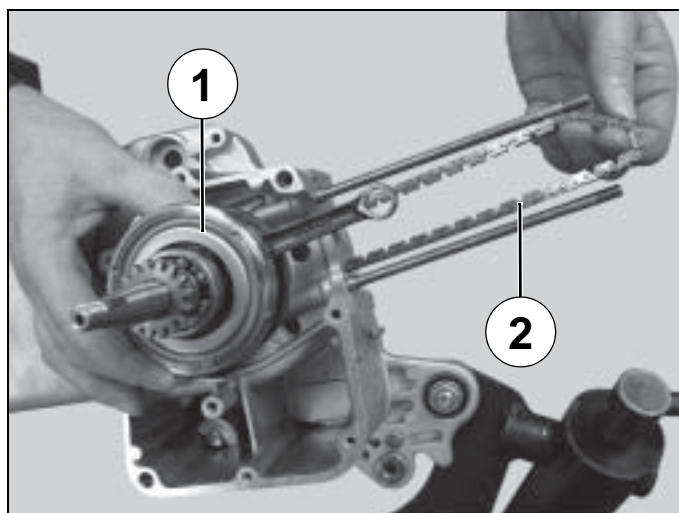

■ Checking the crankshaft and conrod assembly.

- Using a set of shims, check the big end side play.
- The maximum side play on the conrod end must not exceed: **0.55 mm**.

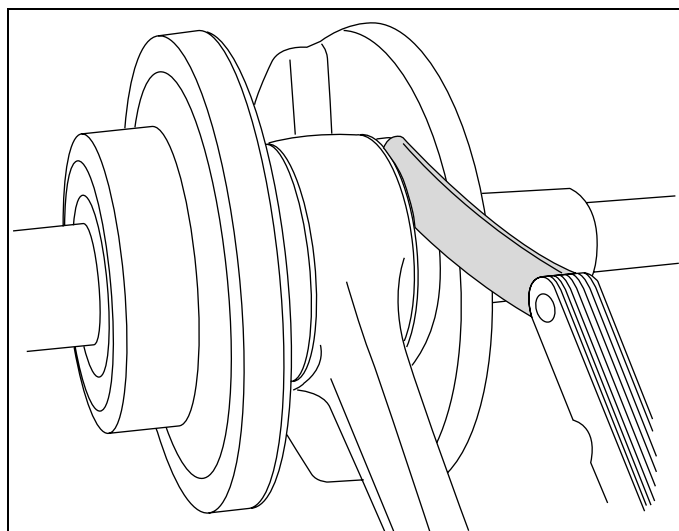

- The out-of-roundness values measured at the ends of the crankshaft should not exceed 0.10 mm.
- 35 mm from the transmission side end (A).
- 27 mm from the flywheel magneto end (B).

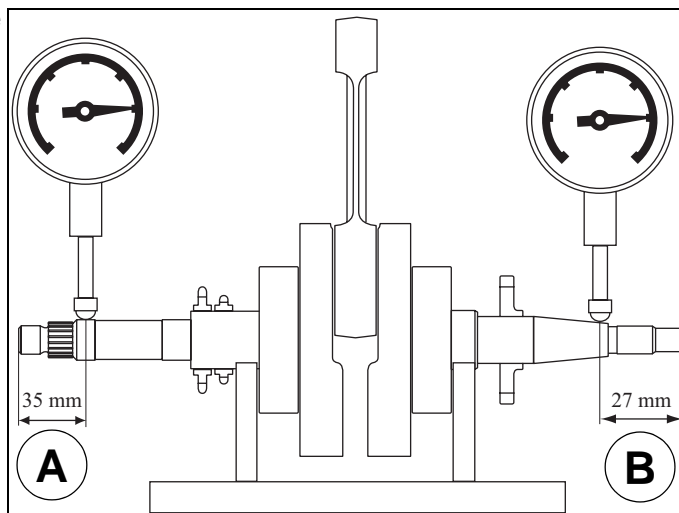

■ Removal of the secondary transmission cover.

- Drain the relay box oil through the drain plug hole (1).
- Filling and checking the transfer box oil level is through the cap (2).

Tightening torque: 1.2 m.daN.

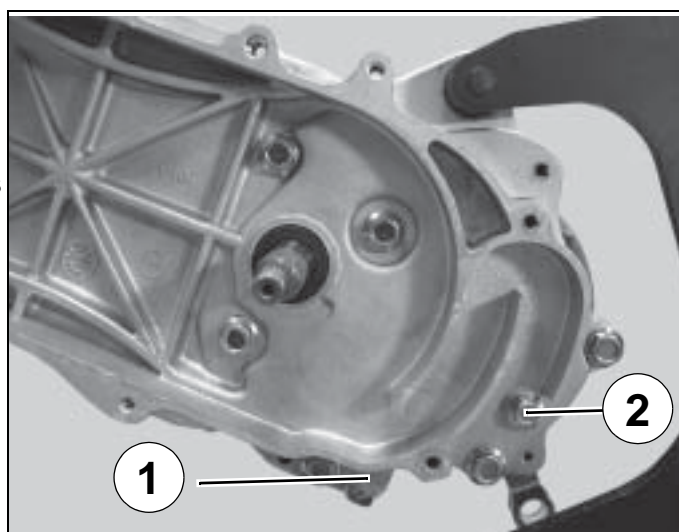

- Remove the 2 fixing bolts (3) (30 mm).
- Remove the fastening screw 4.(35 mm).
- Remove the 3 fixing bolts (5) (40 mm).

Tightening torque: 1.2 m.daN.

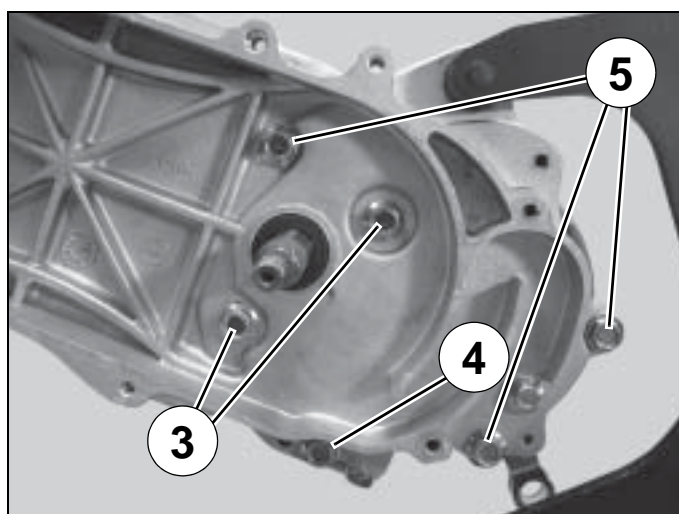

- Remove the secondary transmission cover.
- Remove the 2 centring pillars and the paper gasket.

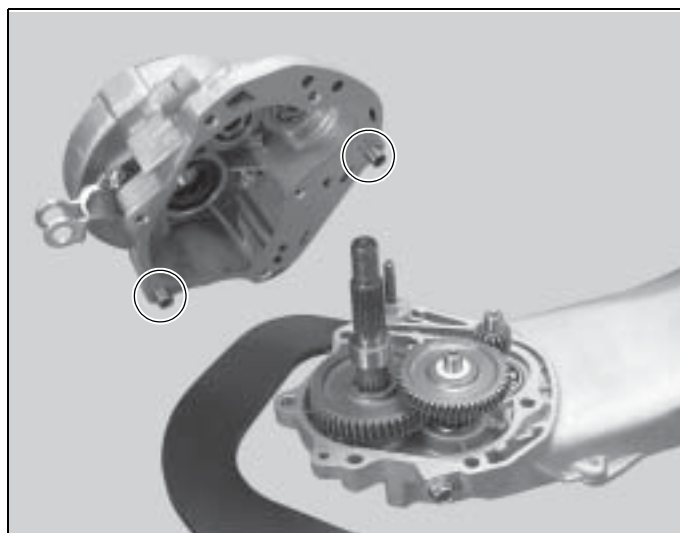

- Remove the first friction washer (1) from the intermediate shaft (2).
- Remove the countershaft (2).

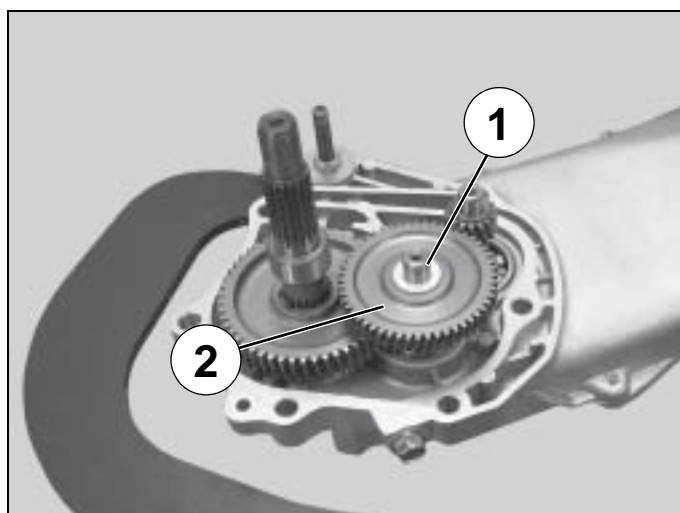

- Remove the secondary shaft (3).
- Remove the pinion (4).
- Remove the primary shaft (5)

Note: The primary shaft can be drifted out of the casing using a mallet.

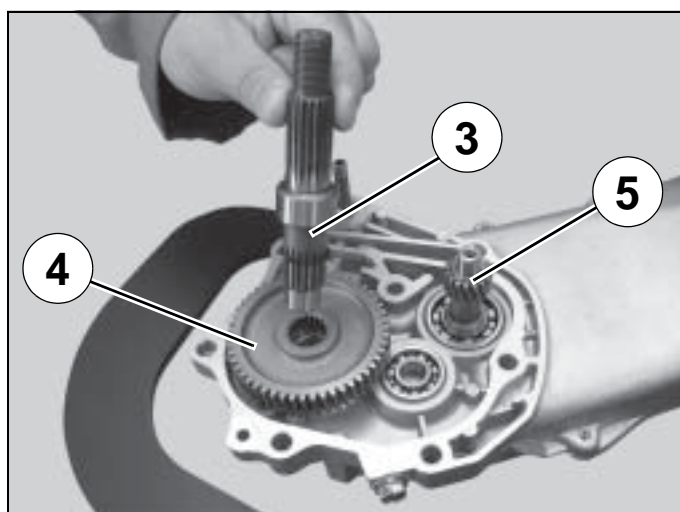

REFITTING SPECIFIC COMPONENTS**■ Assembly of the engine casings.**

Note: Every time the crankcase is opened, change the lip seals.

- Change the lip seal of the crankcase (Position the lip seal using tool P/N 757990).
- Fit the conrod and crankshaft assembly, and the timing chain into the LH crankcase.

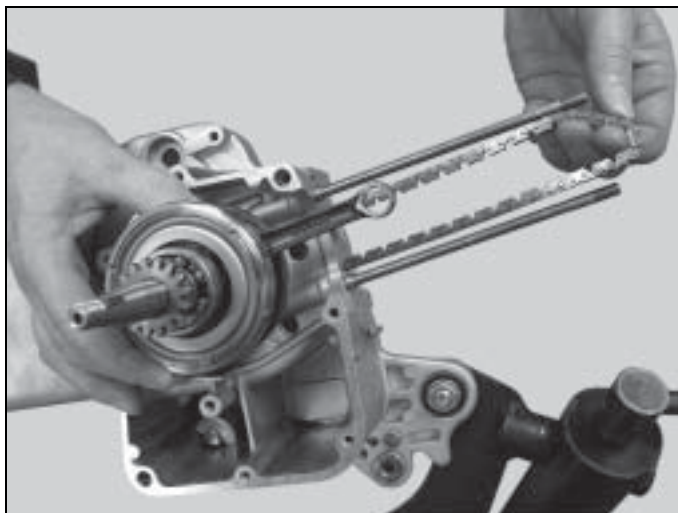

- Install the 2 centring pillars (1).
- Install the gasket (2).

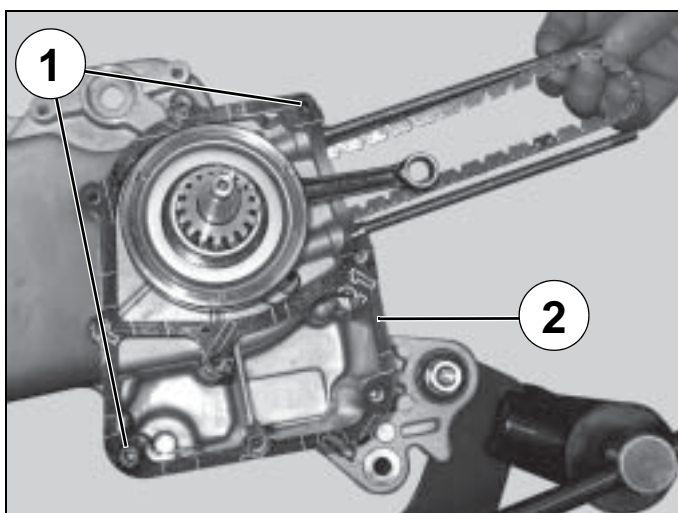

- Place the RH casing over the LH casing.

Note: No tools are necessary for assembling the casings, which shall be carried out without effort.

- Fit the screw (3).
- Fit the centring pillar (4) and the 2 O-rings (5) of the oil pump.

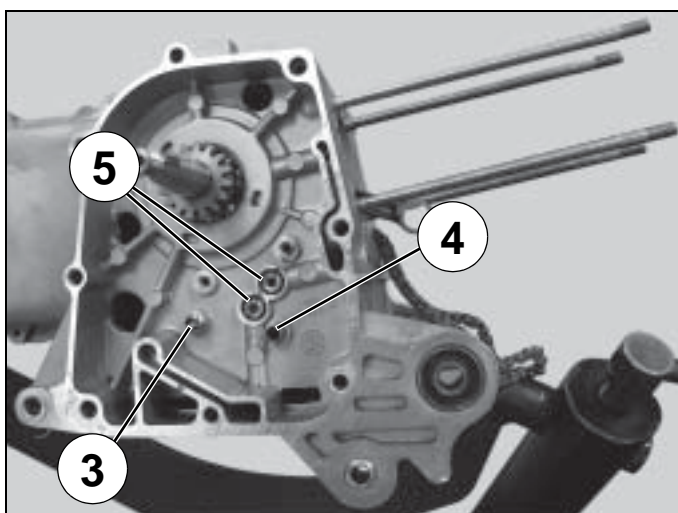

- Install the oil pump.
- Fit the 3 clamping bolts.
- Fit the plastic sprocket that drives the oil pump (6).
- Fit the gasket and the 2 centring pillars.

Tightening torque: 1 m.daN.

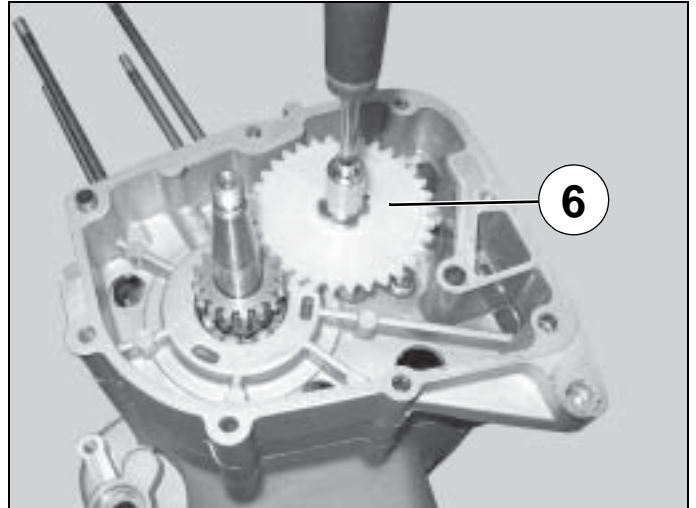

■ Installing the ignition casing.

- Position the lip seal (1) using tool P/N 756668.

Note: Every time the crankcase is opened, change the lip seals.

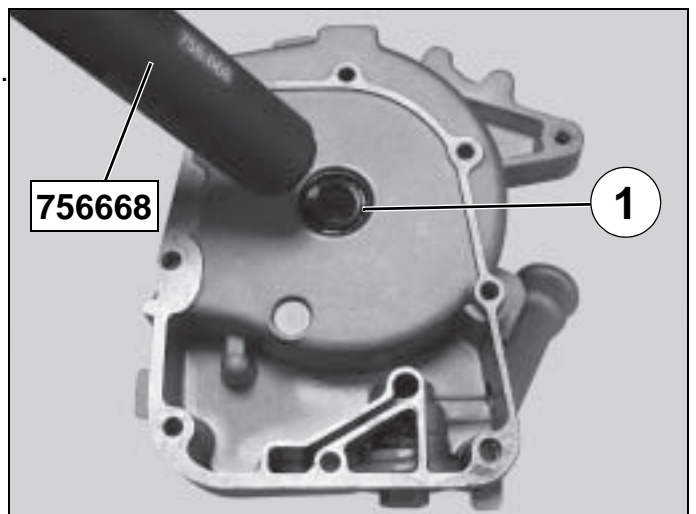

- Install the ignition casing (2).
- Fit the 4 screws (3) (85 mm).
- Fit the 4 screws (4) (100 mm).
- Check the crank assembly turns freely in the casings.

Tightening torque: 1 m.daN.

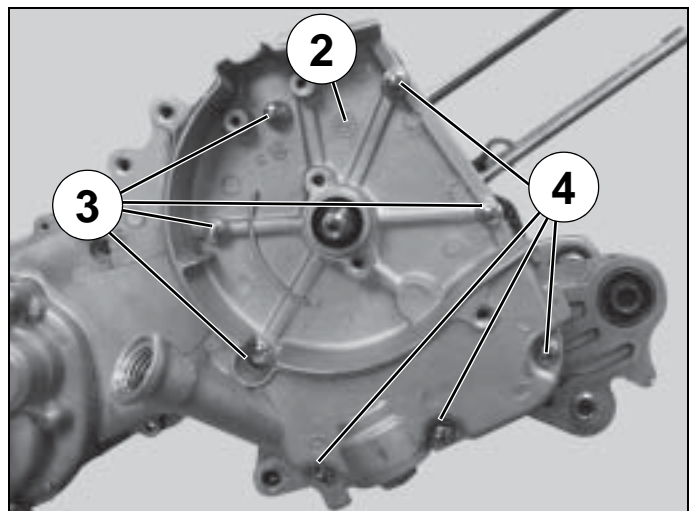

■ Installing the piston rings on the piston.

- Install the spring (1) (no special direction).
- Install the 2 piston rings (2) on each side of the spring by offsetting the gap of each ring (no special direction).
- Install the compression ring (3) by placing the "A" mark upwards.
- Install the top compression ring (4) by placing the "A" mark upwards.

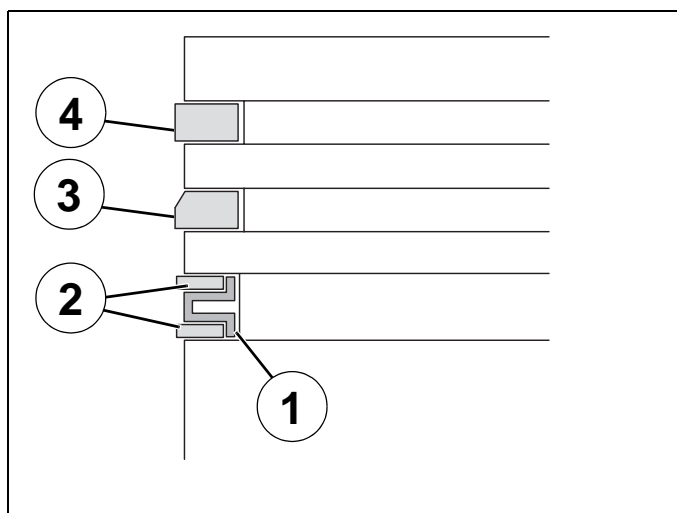

■ Fitting the piston.

- Install the piston so that the recess marked "IN" faces the inlet side.

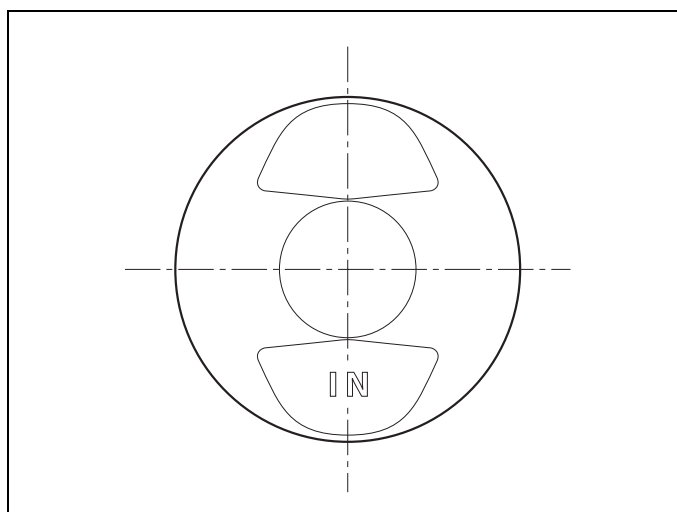

Note: The circlips must be changed every time they are removed.

- The circlip gaps (1) must face upwards or downwards, but under no circumstances to the side.

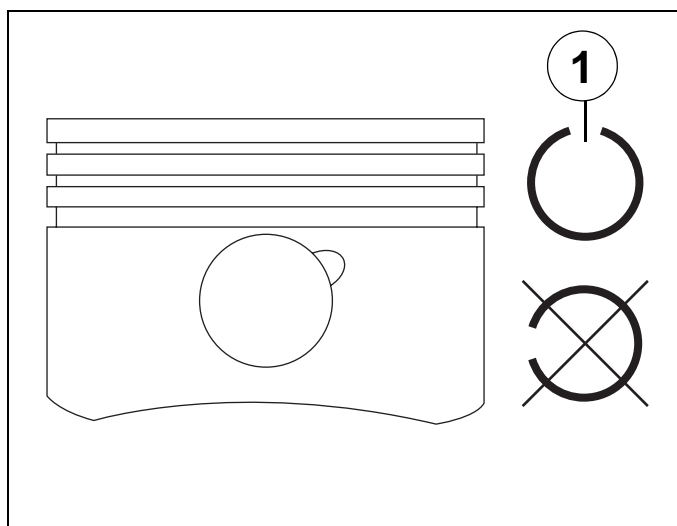

■ Fitting the cylinder.

- Install the cylinder base gasket and the 2 guiding pillars on the crankcase.
- Position the piston ring gap as follows.
 - A. Top compression ring gap.
 - B. Compression ring gap.
 - C. Upper oil control ring gap.
 - D. Lower oil control ring gap.

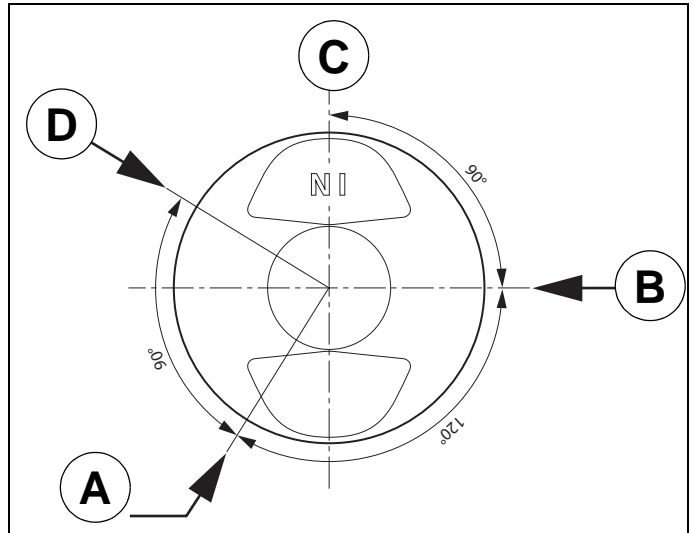

Note: Lubricate the cylinder.

- Fit the timing belt through the cylinder timing well.
- Compress the piston rings and fit them manually one after the other into the cylinder barrel.

Note: The cylinder skirt is chamfered in order to fit the piston rings easily.

- Fit the chain guiding slipper in its housing (A) in the crankcase on the exhaust port side.

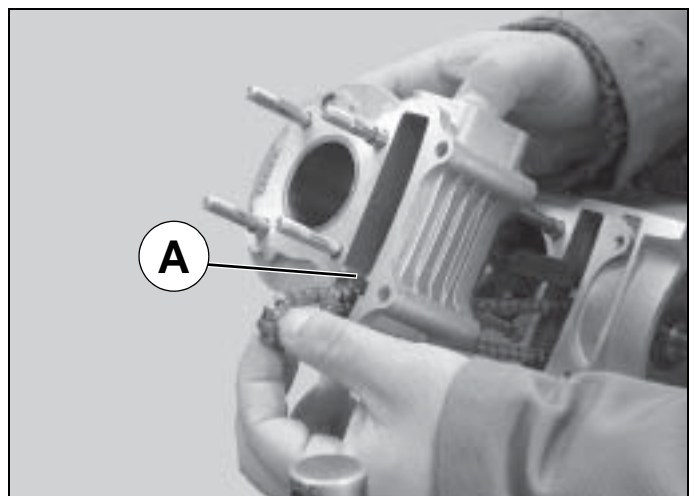

■ Fitting the cylinder head.

- Fit the 2 guiding pillars (1) and the metal gasket (2) on the cylinder.
- Fit the timing chain through the cylinder head timing well.

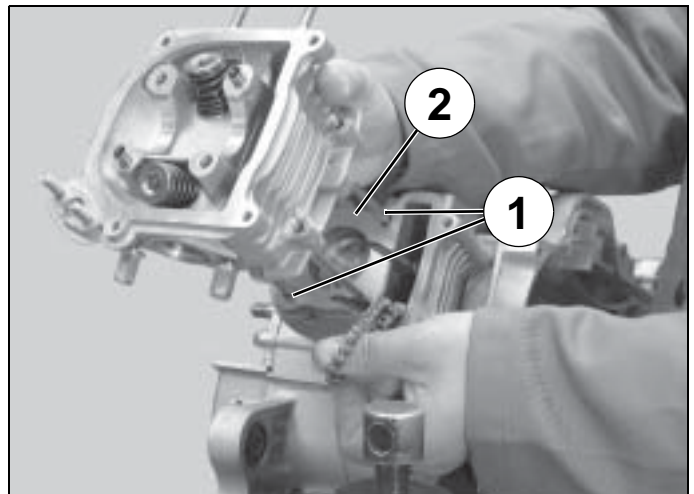

You must set the timing every time you remove the cylinder head when servicing.



■ Setting the timing.

Every time you set the timing you must:

- Remove the volute.
- Remove the automatic tensioner.
- Remove the upper bearing from the camshaft.

- Fit the rotor to the crank ensuring it is positioned on the key.
- Hold the timing chain in position.

Procedure:

- Rotate the flywheel magneto (1) to bring the "T" mark in front of the crankcase boss (2) (clockwise).
- Position the camshaft gear marks as on the the mark (3).
- Fit the timing chain on the camshaft gear (5).
- Make sure the camshaft marks (3) are parallel with the gasket seat surface (4).
- Install the camshaft upper bearing.

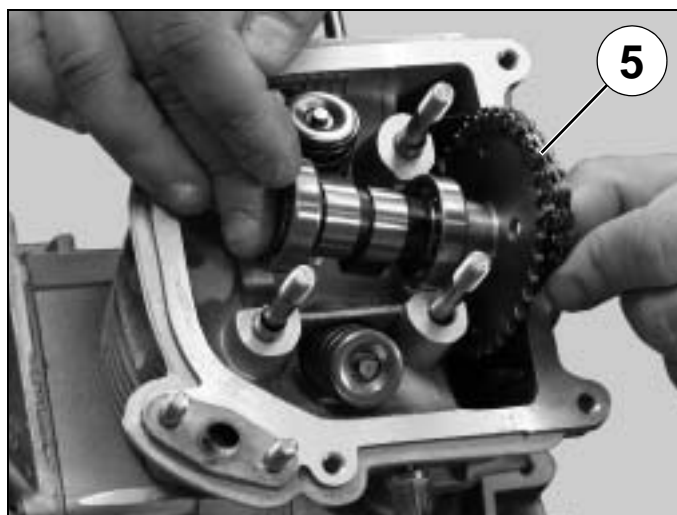
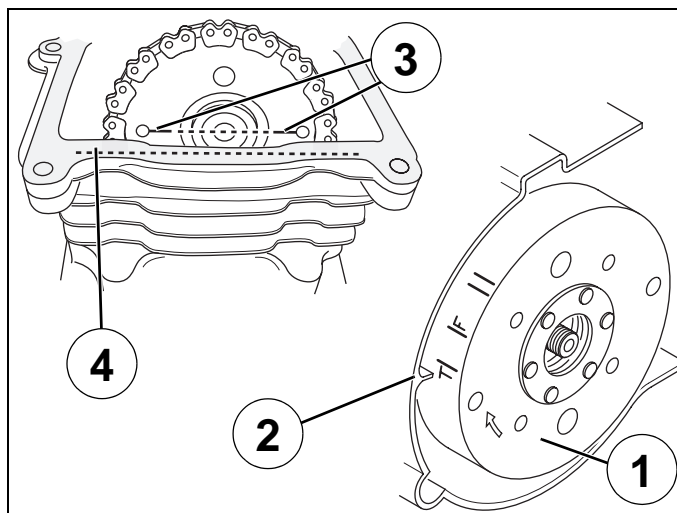

Method for tightening the cylinder head:

This operation is carried out in several steps:

- Slightly lubricate the studs.
- Fit the 4 washers.
- Tighten the 4 nuts (6) and the 2 washer screws (7) slightly.
- Torque the 2 nuts in a crosswise order to 18 Nm and the 2 washer screws to 8 Nm.

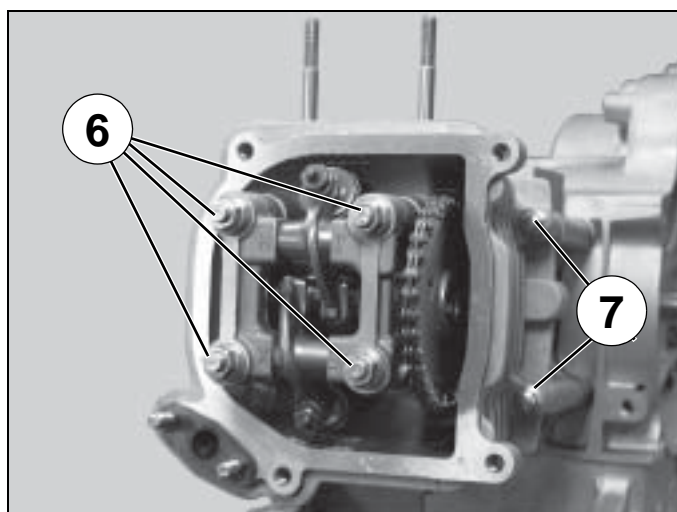

- Install the chain tensioner and the 2 attachment screws (8).
- Install the spring (9).
- Install the screw (10) and its O-ring (11) (check the condition of the O-ring and change it if necessary).

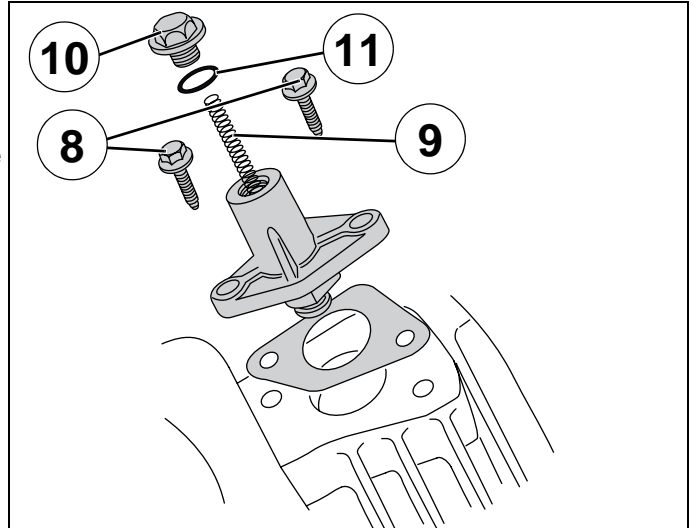
Tightening torque:**Screw 8: 1 m.daN.****Screw 10: 0.8 m.daN.****Checking the timing:**

- Rotate the engine twice: 2 revolutions in the engine's operating direction (clockwise).
- Rotate the flywheel magneto (12) to bring the "T" mark in front of the crankcase boss (13).
- Make sure the camshaft marks (14) are parallel with the gasket seat surface (15).

Note: If the marks are not aligned, reset the valve timing.

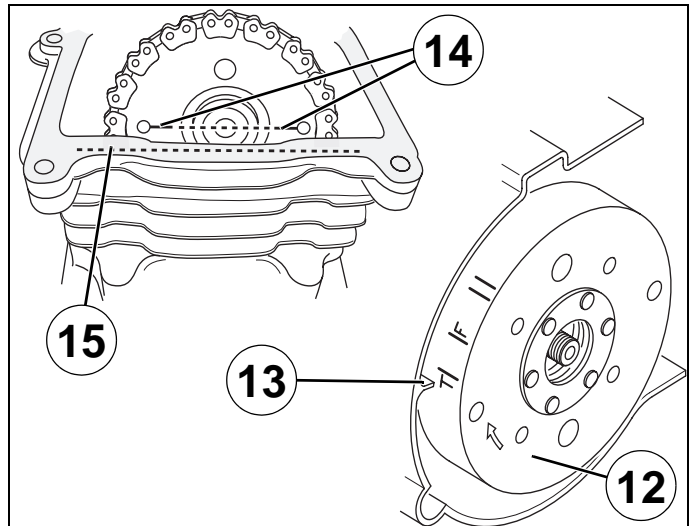
**■ Installing the valve clearance.**

- Rotate the engine manually in the direction of operation in order to bring the rocker pads over the cam lobes (A).

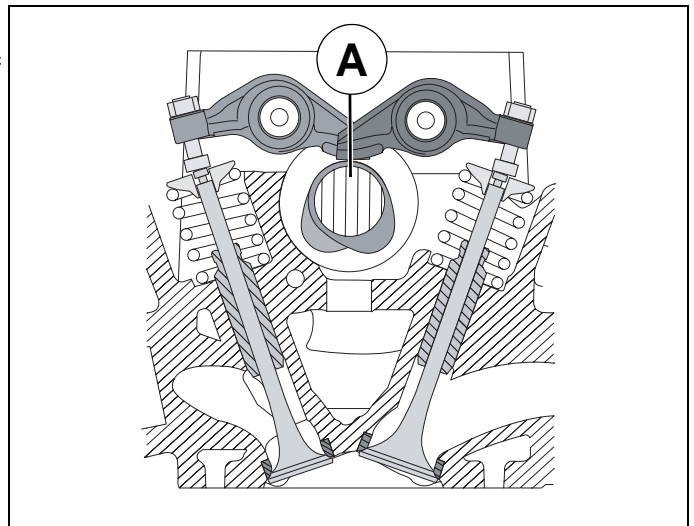

- Loosen the lock nut of the rocker adjustment screw (1).
- By means of feeler gauges, adjust the clearance of every valve by acting on the rocker set screw (2).

Clearances:

- 0.10 mm at the intake.
- 0.10 mm at the exhaust.

- Immobilize the rocker set screw.
- Tighten the locknut without altering the adjustment.

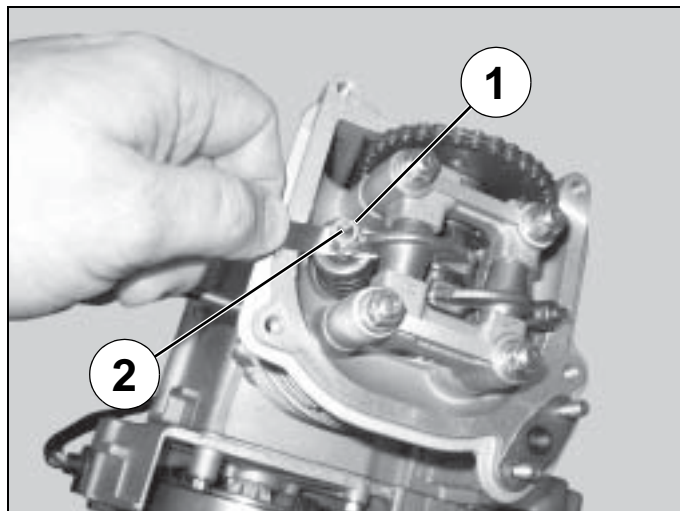

■ Checking the valve clearance.

- At the intake a 0.15 feeler gauge shouldn't go.
- At the exhaust a 0.15 feeler gauge shouldn't go.

On the contrary, if the feeler gauge goes, reset the clearances.

■ Installing the winding and the pick-up.

- Position the winding as shown.
- Fit the 2 screws (1).
- Fit the 2 screws (2).

Tightening torque:

Screw 1: 0.6 m.daN.

Screw 2: 0.8 m.daN.

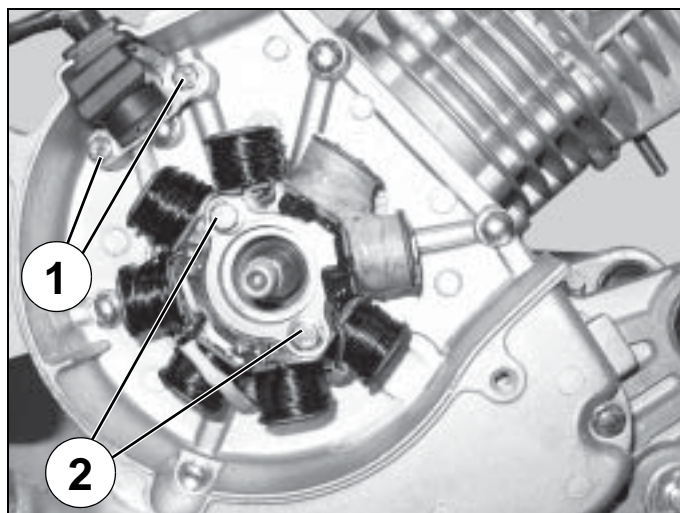

Note: When re-installing, make sure the key (3) is properly positioned on the crankshaft stem as shown in the figure.

- Fit the rotor to the crank ensuring it is positioned on the key.
- Lock the rotor with the adjustable pin wrench P/N **752237**.
- Fit and tighten the rotor nut.

Tightening torque: 5 m.daN.

Important: Using an inappropriate tool can damage the windings of the flywheel magneto.

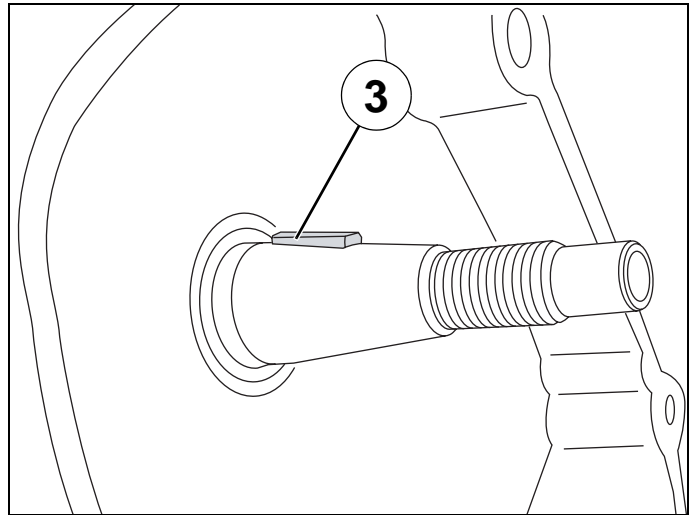

MISCELLANEOUS OPERATIONS

■ **Removal of the starter system.**

- Remove the 8 bolts that secure the cover.
- Remove the transmission cover.
- Removal of the gasket.
- Remove the 2 centring pillars.

Tightening torque: 1 m.daN.

Note: Every time it is removed, change the gasket.

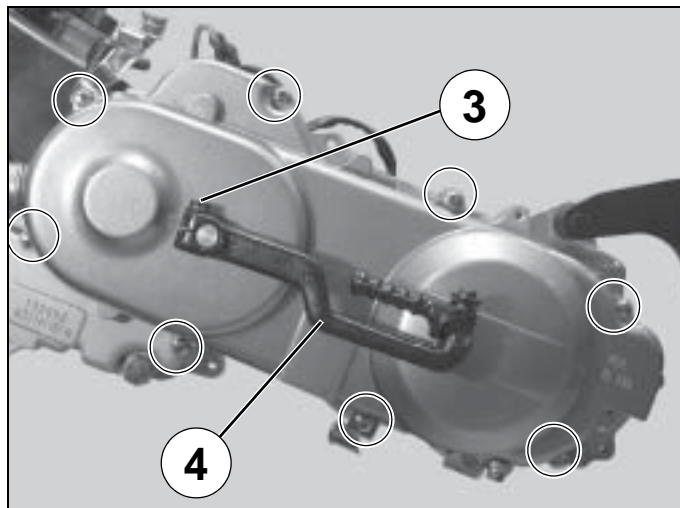

- Actuate the kick starter gear sector (1) by hand and remove the kick starter drive piece (2) and washer.
- Remove the kickstart pedal securing bolt (3).
- Remove the kickstart pedal (4).
- Remove the circlip.
- Remove the washer, the starter gear sector (1) and the spring (5) of the drive train cover.
- Remove the anti-noise ring (6).

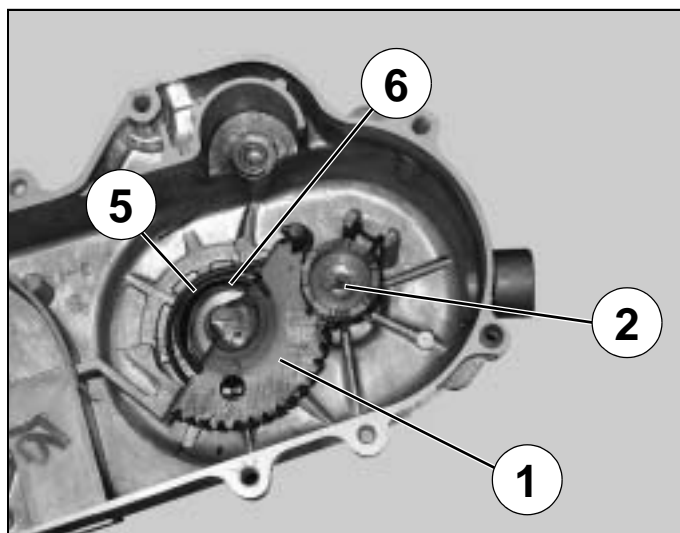

■ Fitting the starter system

- Fit the return spring (1), hook the longest buckle on the cover's pin (A).
- Install the anti-noise ring (2).
- Fit the starter gear sector (3) into the lubricated bearing sleeve.
- Hook the second buckle (B) of the spring onto the starter gear sector.
- Wind the spring so as to position the kick starter sector on the stop (C) of the cover.
- Turn over the cover, fit the washer and the circlip on the the gear sector spindle.
- Fit the washer on the housing of the kick starter drive piece.
- Wind approximately 1/8th of a turn the gear sector so as to place the kick starter drive piece (4).
- Position the pin (5) of the kick starter drive piece around the boss (D) of the housing.

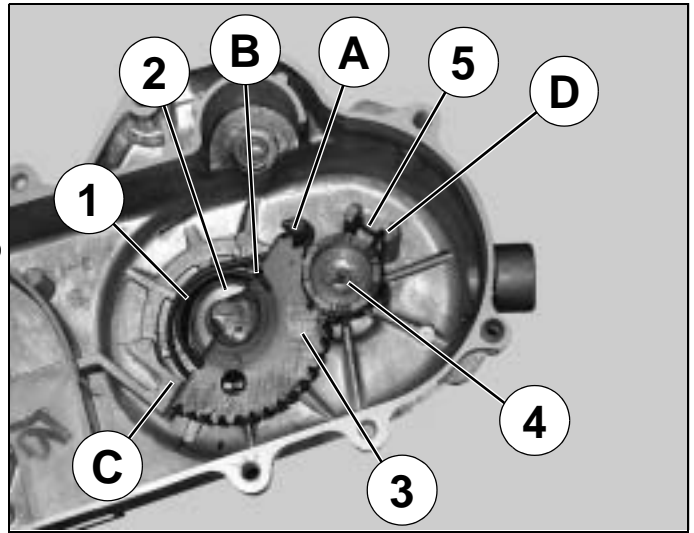

■ Changing the drive pulley bearings.

- Remove the 8 bolts that secure the cover.
- Remove the transmission cover.
- Removal of the gasket.
- Remove the 2 centring pillars.

Tightening torque: 1 m.daN.

Note: Every time it is removed, change the gasket.

- Hold the fixed flange with tool P/N 759467.
- Remove the nut (1) and washer (2) from the fixed flange.
- Remove the starter hub (3) and the turbine (4).
- Remove the fixed flange (5).
- Remove the belt.
- Remove the drive pulley (6) with the guide hub (7).
- Remove the washer (8).

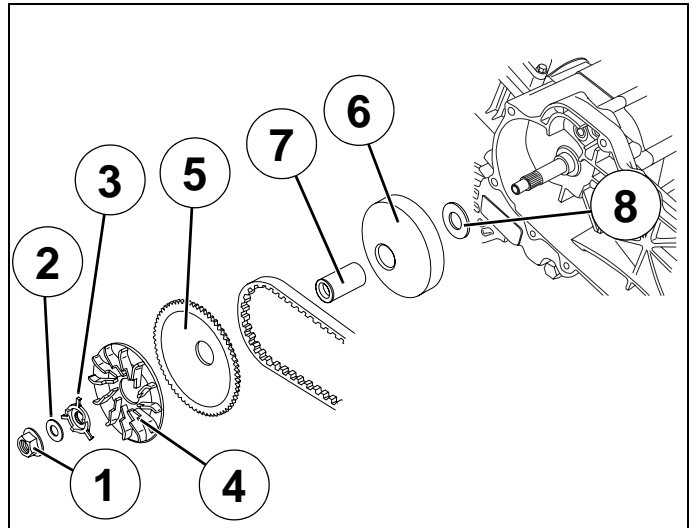

- Remove the 3 screws (9) that secure the bump-stop (10).
- Remove the bump-stop (10).
- Remove the ramp (11) and its 3 guides (12).
- Remove the moving flange (14) and 6 bearings (13).

Note: The bearings must be changed if they show major signs of wear.

Re-assembly:

- Proceed in reverse order to disassembly and do not grease the bearings.
- Grease the moving flange bore lightly (high temperature grease).

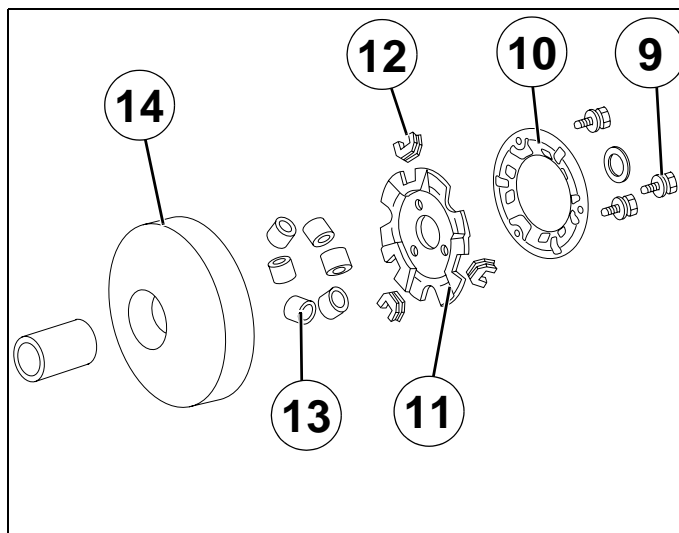

■ Fitting the drive pulley assembly.

- Fit washer (1).
- Install the drive pulley (2) and its guide hub (3) onto the crankshaft assembly (4).

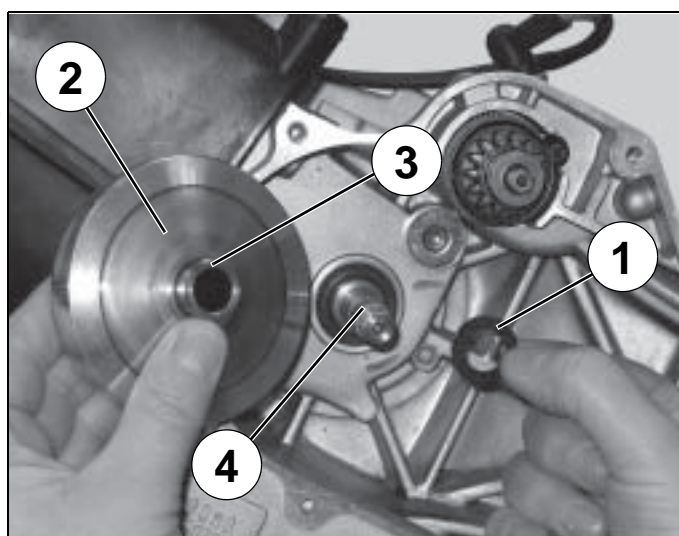

- Fit the belt (5) to the guide hub (6).
- Fit the fixed flange (7) to the crank assembly checking it is properly positioned on the crank assembly splines.
- Install the turbine (8) and the driving hub (9) over the crankshaft splines.
- Fit the washer (10) and the nut (11) and hand tighten.
- Hold the fixed flange with tool P/N 759467.
- Tighten the nut.

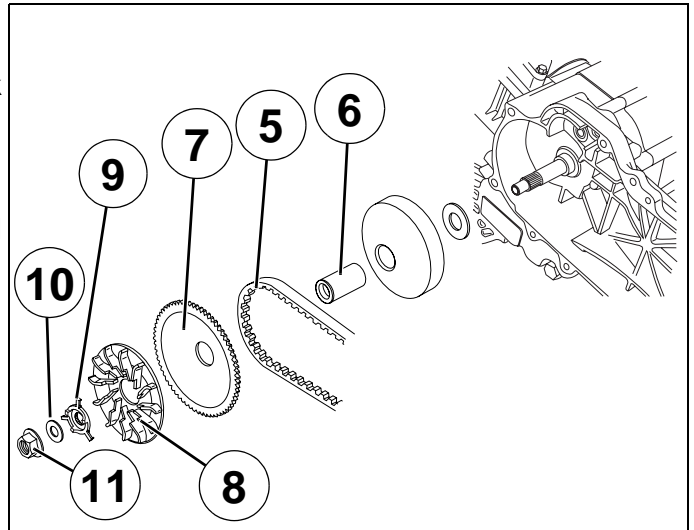

Tightening torque: 5 m.daN.

Note: Do not over-grease to avoid splashing the belt.



Precautions when refitting the drive pulley:

Drive pulley components shall neither be suppressed nor have their size reduced.

Any modifications may cause the nut to tighten against the crankshaft splines instead of the fixed flange and damage the crankshaft splines.

■ Removal of the clutch lining assembly.

- Remove the 8 bolts that secure the cover.
- Remove the transmission cover.
- Removal of the gasket.
- Remove the 2 centring pillars.

Tightening torque: 1 m.daN.

Note: Every time it is removed, change the gasket.

- Lock the clutch drum with the pin wrench P/N 752237.
- Remove the nut.
- Clamp the 2 strands of the belt to lower it between the flanges.
- Remove the clutch drum, the clutch drive pulley and driven pulley assembly and belt.
- Compress the clutch drive pulley and driven pulley assembly with the tool P/N 752127 clamped in the jaws of a vice.
- Remove nut (1) using spanner P/N 756725.
- Slacken tool P/N 752127.

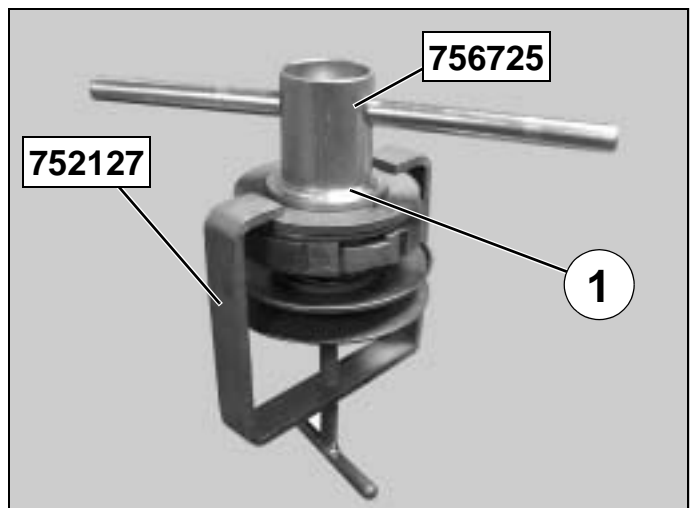

- Remove the clutch linings (2), the upper centring sleeve (3), the spring (4), and the lower centring sleeve (5).
- Remove the 3 pins (6) from the variable speed drive seat.
- Separate the fixed (7) and rotating (8) flanges.

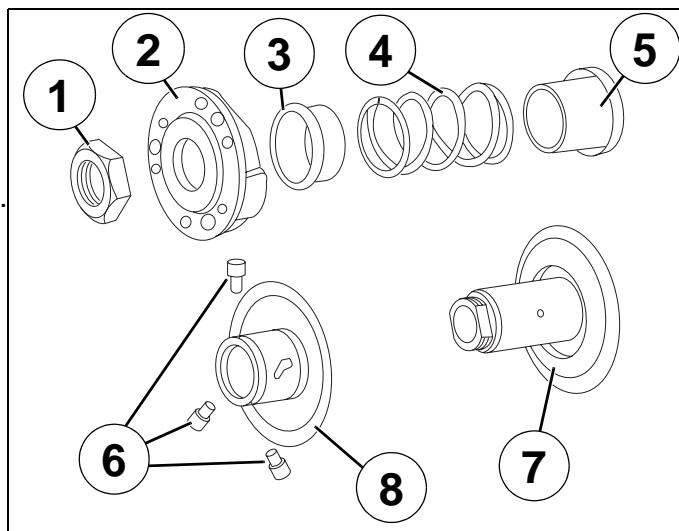

■ Refitting the clutch lining assembly.

- After checking the 2 lip seals (1) and the 2 O-rings (2) of the rotating flange (3) are in good condition, grease the governor seat 3 pins (4) (high temperature grease) and assemble the parts in reverse order to removal.
- Compress the clutch drive pulley and driven pulley assembly with the tool P/N 752127.
- Tighten the nut.

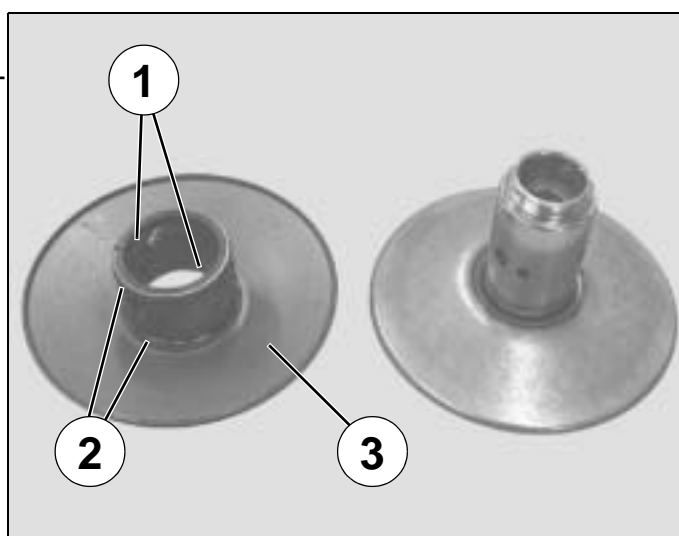

Tightening torque: 5 m.daN.

Note: Before fitting the clutch drive pulley and driven pulley to the input shaft, fit the belt into the pulley bottom by opening the flanges by hand.

- Fit the clutch drive pulley and driven pulley assembly.
- Fit the clutch cover.
- Fit and tighten the nut.

Tightening torque: 5 m.daN.

- Install the 2 centring pillars.
- Install the transmission cover.
- Fit and tighten the cover 8 fixing bolts.

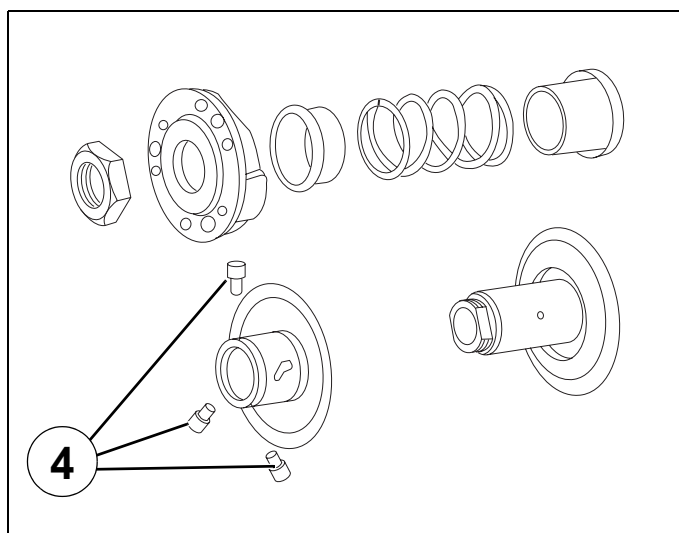

Tightening torque: 1 m.daN.



■ Removal of the choke.

- Remove the choke cap (1).
- Remove the screw (2) and the holder plate (3).
- Locate the position of the choke (4) and then remove it.

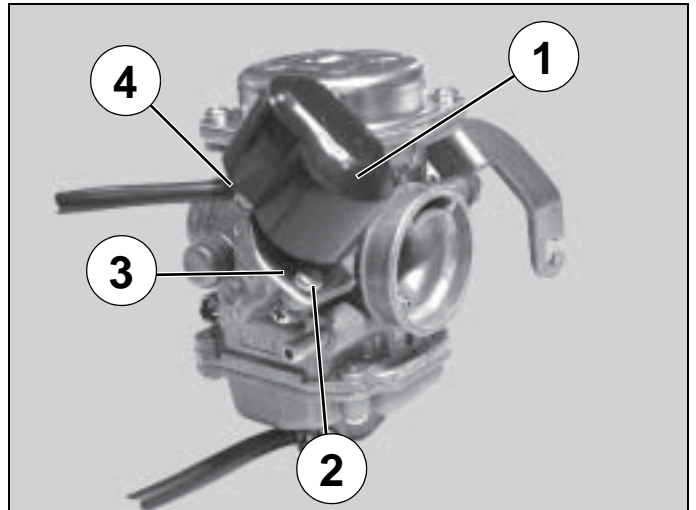

- Remove the 2 screws that secure the choke (5).
- Remove the choke holder and its gasket.

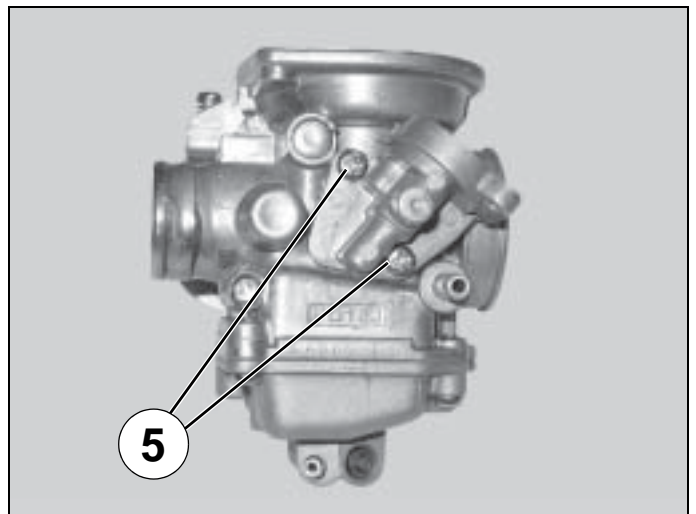

■ Removal of the throttle valve.

- Remove the 2 screws that secure the chamber cap (1).
- Remove the chamber cap (2).
- Remove the spring.
- Remove the needle, valve and membrane assembly.

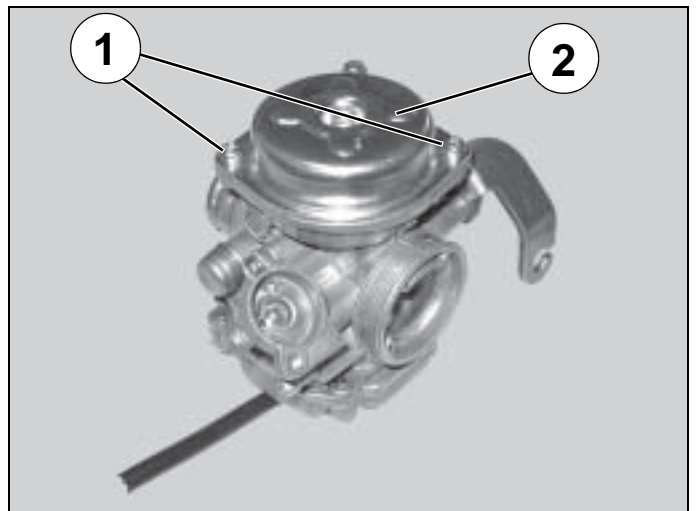

- Remove the needle stop (1) and its spring (2) by rotating it a 1/4 turn.
- Remove the needle and its washer (3).

Note: The height of the needle is factory set and cannot be modified.

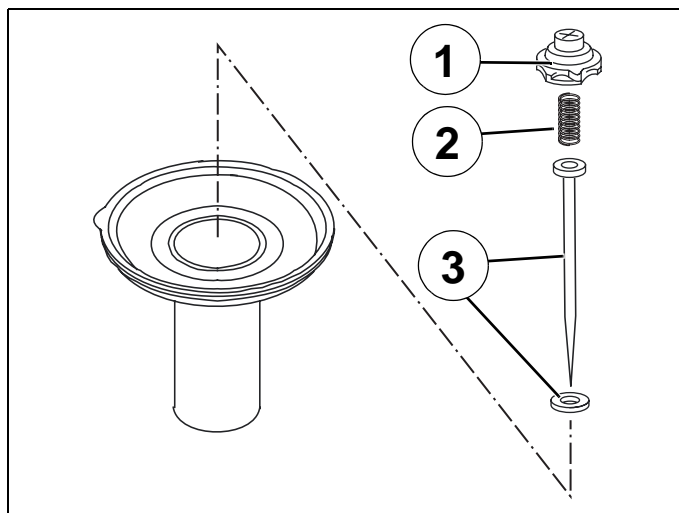

■ Removal of the float, needle valve and jets.

- Remove the 3 screws that secure the float chamber (1).
- Remove the float chamber and its O-ring.

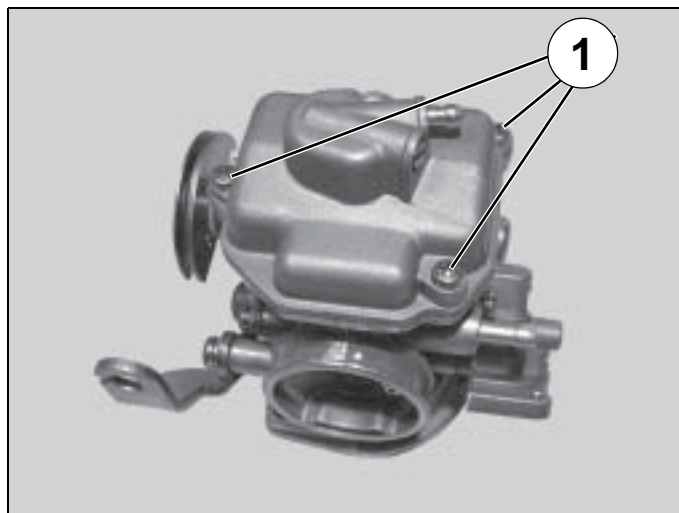

- Remove the float (2), its pin (3) and the needle valve (4).

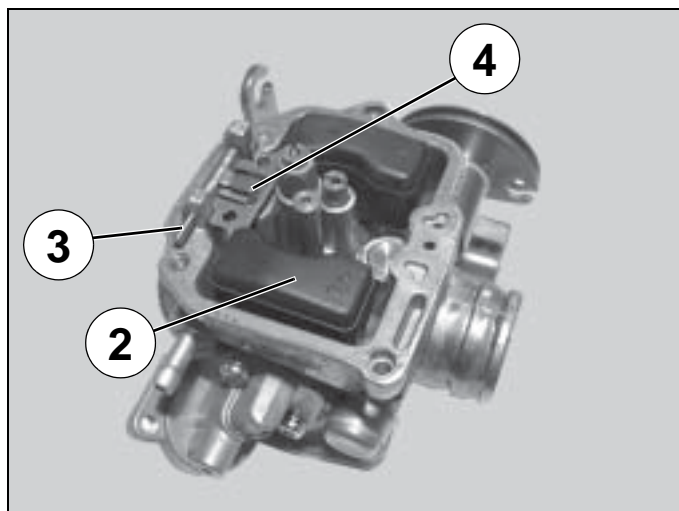

- Remove the idle jet (5).
- Remove the main jet (6).
- Remove the needle well (7).

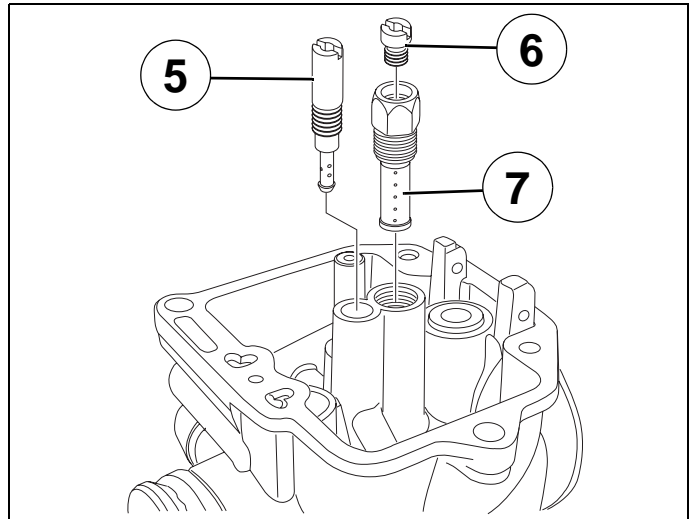

Note:

**Check the condition of the needle valve and the needle valve seat (A).
Check the condition of the float chamber O-ring.**

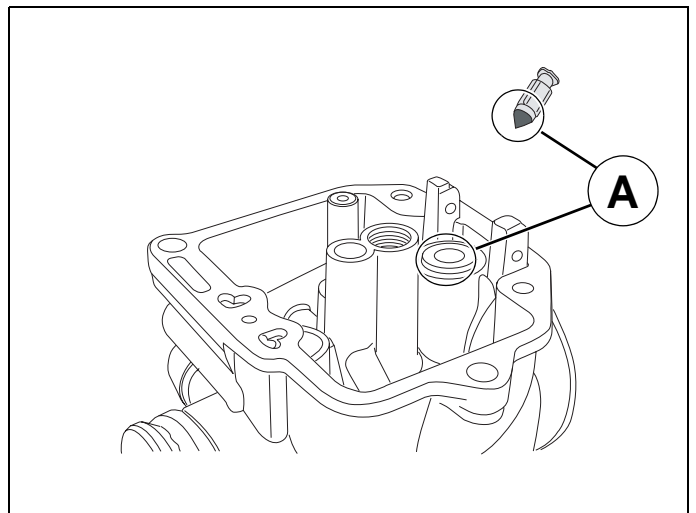

■ Removal of the engine speed adjuster screw and mixture control screw.

- Turn clockwise the engine speed adjuster screw (1) while counting the number of turns until it is screwed home.

Note: When re-fitting, this operation allows you to put it back to its initial adjustment position.

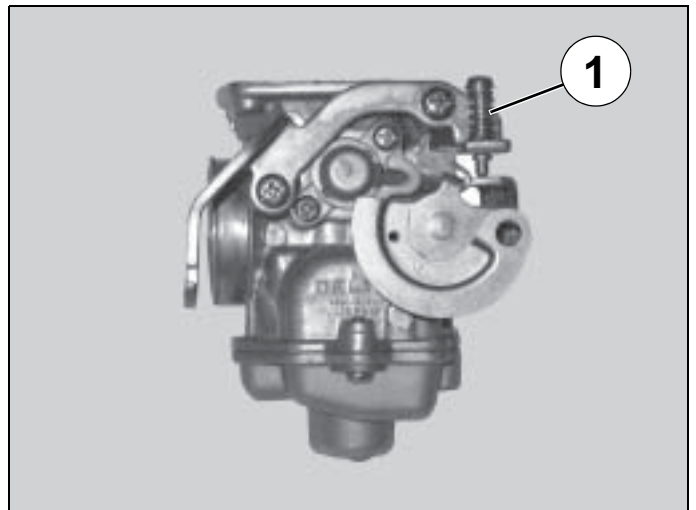

- Turn clockwise the mixture control screw (2) while counting the number of turns until it is screwed home.

Note: When re-fitting, this operation allows you to put it back to its initial adjustment position.

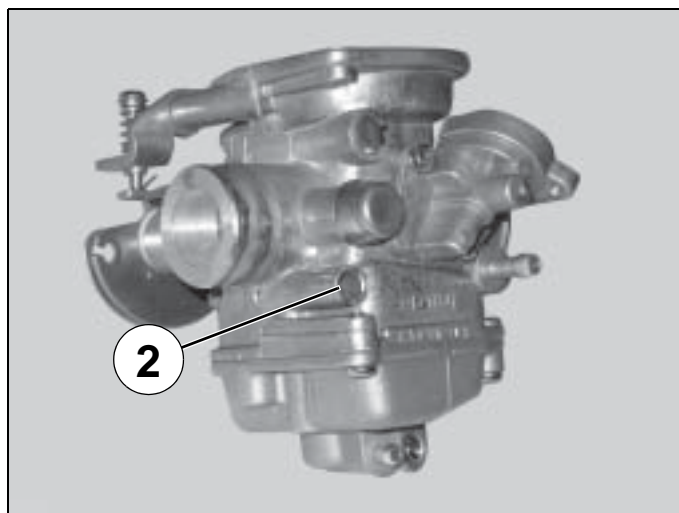

- Clean the carburettor body and its components with a cleanser Biosane P/N 754748.
- Blow into every jet and duct of the carburettor body with compressed air.

Note: Do not use any metal tool which can damage the ducts of these items.









 **UTAC**
CERTIFICATION
SYSTEMES QUALITE
ISO 9001
Certificat n° SQ/0766-3

P/N 759517

In our permanent concern to make improvements PEUGEOT MOTOCYCLES reserves the right to suppress, modify, or add any reference mentioned.

DC/PS/APV Printed in the E.U. 02/2007 (non contractual pictures)

