



SERVICE STATION MANUAL

639189



Runner RST 50 SP



SERVICE STATION MANUAL

Runner RST 50 SP

The descriptions and illustrations given in this publication are not binding. While the basic specifications as described and illustrated in this manual remain unchanged, PIAGGIO-GILERA reserves the right, at any time and without being required to update this publication beforehand, to make any changes to components, parts or accessories, which it considers necessary to improve the product or which are required for manufacturing or construction reasons.

Not all versions/models shown in this publication are available in all countries. The availability of single versions should be checked at the official Piaggio sales network.

"© Copyright 2007 - PIAGGIO & C. S.p.A. Pontedera. All rights reserved. Reproduction of this publication in whole or in part is prohibited."

PIAGGIO & C. S.p.A. - After-Sales

V.le Rinaldo Piaggio, 23 - 56025 PONTEDERA (Pi)

SERVICE STATION MANUAL

Runner RST 50 SP

This workshop manual has been drawn up by Piaggio & C. Spa to be used by the workshops of Piaggio-Gilera dealers. This manual is addressed to Piaggio service mechanics who are supposed to have a basic knowledge of mechanics principles and of vehicle fixing techniques and procedures. Any important changes made to the vehicles or to specific repair operations will be promptly reported by updates to this manual. Nevertheless, no fixing work can be satisfactory if the necessary equipment and tools are unavailable. It is therefore advisable to read the sections of this manual relating to specific tools, along with the specific tool catalogue.

N.B. Provides key information to make the procedure easier to understand and carry out.

CAUTION Refers to specific procedures to carry out for preventing damages to the vehicle.

WARNING Refers to specific procedures to carry out to prevent injuries to the repairer.



Personal safety Failure to completely observe these instructions will result in serious risk of personal injury.



Safeguarding the environment Sections marked with this symbol indicate the correct use of the vehicle to prevent damaging the environment.



Vehicle intactness The incomplete or non-observance of these regulations leads to the risk of serious damage to the vehicle and sometimes even the invalidity of the guarantee.



INDEX OF TOPICS

CHARACTERISTICS

CHAR

TOOLING

TOOL

MAINTENANCE

MAIN

TROUBLESHOOTING

TROUBL

ELECTRICAL SYSTEM

ELE SYS

ENGINE FROM VEHICLE

ENG VE

ENGINE

ENG

SUSPENSIONS

SUSP

BRAKING SYSTEM

BRAK SYS

COOLING SYSTEM

COOL SYS

CHASSIS

CHAS

PRE-DELIVERY

PRE DE

TIME

TIME

INDEX OF TOPICS

CHARACTERISTICS

CHAR

This section describes the general specifications of the vehicle.

Rules

This section describes general safety rules for any maintenance operations performed on the vehicle.

Safety rules

- If work can only be done on the vehicle with the engine running, make sure that the premises are well-ventilated, using special extractors if necessary; never let the engine run in an enclosed area. Exhaust fumes are toxic.
 - The battery electrolyte contains sulphuric acid. Protect your eyes, clothes and skin. Sulphuric acid is highly corrosive; in the event of contact with your eyes or skin, rinse thoroughly with abundant water and seek immediate medical attention.
 - The battery produces hydrogen, a gas that can be highly explosive. Do not smoke and avoid sparks or flames near the battery, especially when charging it.
 - Fuel is highly flammable and it can be explosive given some conditions. Do not smoke in the working area, and avoid naked flames or sparks.
 - Clean the brake pads in a well-ventilated area, directing the jet of compressed air in such a way that you do not breathe in the dust produced by the wear of the friction material. Even though the latter contains no asbestos, inhaling dust is harmful.
-

Maintenance rules

- Use original PIAGGIO spare parts and lubricants recommended by the Manufacturer. Non-original or non-conforming spares may damage the vehicle.
 - Use only the appropriate tools designed for this vehicle.
 - Always use new gaskets, sealing rings and split pins upon refitting.
 - After removal, clean the components using non-flammable or low flash-point solvents. Lubricate all the work surfaces, except tapered couplings, before refitting these parts.
 - After refitting, make sure that all the components have been installed correctly and work properly.
 - For removal, overhaul and refit operations use only tools with metric measures. Metric bolts, nuts and screws are not interchangeable with coupling members with English sizes. Using unsuitable coupling members and tools may damage the scooter.
 - When carrying out maintenance operations on the vehicle that involve the electrical system, make sure the electric connections have been made properly, particularly the ground and battery connections.
-

Vehicle identification

Frame prefix: ZAPC46100

Engine prefix: M461M

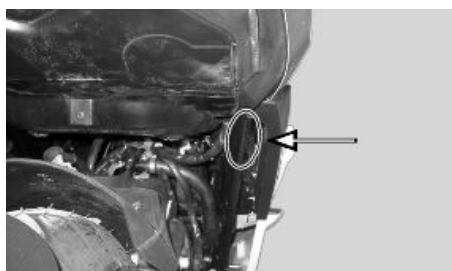

Dimensions and mass

DIMENSIONS

Specification	Desc./Quantity
Total weight when empty and ready for road	103 kg (95 kg dry)
Length	1840 mm
Width	750 mm
Wheelbase	1270 mm
Height	1210 mm

Engine

MOTORE

Specification	Desc./Quantity
Type of engine	One-cylinder 2 speed Piaggio Hi-PER2 PRO
Bore x stroke	40 X 39.3 mm
Compression ratio	11.3 ÷ 12.8 : 1
Engine capacity	49 cm ³
Carburettor	DELL'ORTO PHVA 17.5 ID
CO adjustment	3.5% ± 0.5
Engine idle speed	1800 to 2000 r.p.m.
Air filter	Sponge impregnated with fuel mixture (50% SELENIA air filter oil and 50% unleaded petrol).
Starting system	electric starter/kickstarter
Lubrication	With blend and variable oil variable according to the engine revolutions and the throttle valve opening by means of a pump controlled by the driving shaft with toothed belt.
Fuel supply:	With the fuel pump in depression, lead-free gasoline (with 95 octane minimum) by means of the carburettor
Cooling system	Through circulation of cooling liquid

Transmission

TRANSMISSION

Specification	Desc./Quantity
Transmission	With automatic expandable pulley variator, torque server, V belt, automatic clutch, gear reduction unit.

Capacities

CAPACITY

Specification	Desc./Quantity
Gas tank	In plastic, 7 lt. capacity (approximate value) including the ~ 1.7 l. reserves.
Oil tank mixer	In plastic, 1.6 l. capacity (approximate value) including the ~ 0.6 l. reserves.
Rear hub oil	Quantity: approx. 75 cm ³

Electrical system

IMPIANTO ELETTRICO

Specification	Desc./Quantity
Type of ignition	Capacitive discharge type electronic ignition, with incorporated high voltage coil
Ignition advance (before dead centre.)	16° ± 1° AT 4000 rpm
Sparkplug (One-cylinder two-stroke liquid cooled)	CHAMPION RN1C
Battery	12V-4Ah
Main fuse	7.5 A
Generator	In alternate current with three output sections

Frame and suspensions

FRAME

Specification	Desc./Quantity
Chassis type	Welded tubular steel chassis with stamped sheet reinforcements
Front suspension	Hydraulic fork with upside down rods
Front fork stroke	73 mm
Front stroke	66 mm
Rear suspension	single hydraulic shock absorber, coaxial helical spring. Frame engine attachment with swinging arm.
Rear suspension stroke	63.5 mm

Brakes

BRAKES

Specification	Desc./Quantity
Front brake	Ø 220 mm disc brake with hydraulic linkage (r.h. brake lever).
Rear brake	Ø 175 mm disc (hydraulically controlled via lever on left hand-side of handlebar)

Wheels and tyres

WHEELS AND TIRES

Specification	Desc./Quantity
Front wheel rim	In diecast aluminium alloy - 3.00x14"
Rear wheel rim	In diecast aluminium alloy - 3.50x13"
Front tire	120/70 - 14" 55L Tubeless
Rear tire	140/60 - 13" 57L Tubeless

Secondary air

To clean the sponge filters of the secondary air system, proceed as follows:

Unscrew the two studs (2) of the aluminium lid of the secondary air box to access the polyurethane sponge contained inside the box; after cleaning with water and neutral soap, dry the sponge with a clean cloth and reassemble the system, checking that the steel blade is not warped and/or does not guarantee the seal on its strike surface; replace if necessary.

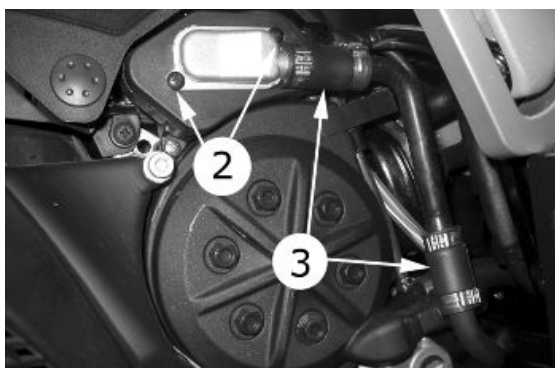

N.B.

UPON REFITTING, MAKE SURE TO CORRECTLY FIT THE TAB IN ITS FITTING ON THE TWO PLASTIC AND ALUMINIUM COVERS.

CAUTION

DURING THE OPERATION, CHECK THE INTEGRITY AND SEAL OF THE TWO SLEEVES (3) IN RUBBER LOCATED AT THE ENDS OF THE SECONDARY AIR HOSE; IF NECESSARY, REPLACE THEM USING NEW CLAMPS TO FASTEN.

Carburettor

50cc Version

Dell'Orto

DELL'ORTO CARBURETTOR

Specification	Desc./Quantity
Type	PHVA 17.5 ID
Diffuser diameter	Ø 17.5
Reference number of adjustment	8439
Maximum nozzle:	53
Maximum air nozzle (on the body):	Ø 1.5
Tapered pin stamped code:	A22
Pin position (notches from above):	1
Diffuser:	209 HA

Specification	Desc./Quantity
Minimum nozzle:	32
Minimum air nozzle (on the body):	Free
Secondary minimum air hole	Ø 2.5
Initial minimum mix screw opening:	1 1/2
Starter jet	50
Starter air nozzle (on the body):	Ø 1.5
Stroke of starter pin:	11 mm
Fuel inlet hole	Ø 1.0

Tightening Torques

TORQUE IN Nm BY TYPE OF TIGHTENED MATERIAL

Name	Torque in Nm
M4 Ø 8.8 steel screw on plastic with metallic spacers	2
M4 Ø 8.8 steel screw on brass, copper, aluminium and their alloys	2
M4 Ø 8.8 steel screw Iron, steel	3
M5 Ø 8.8 steel screw on plastic with metallic spacers	4
M5 Ø 8.8 steel screw on brass, copper, aluminium and their alloys	4
M5 Ø 8.8 steel screw Iron, steel	6
M6 Ø 8.8 steel screw on plastic with metallic spacers	6.5
M6 Ø 8.8 steel screw on brass, copper, aluminium and their alloys	6.5
M6 Ø 8.8 steel screw Iron, steel	10.5
M7 Ø 8.8 steel screw on brass, copper, aluminium and their alloys	10.5
M7 Ø 8.8 steel screw Iron, steel	17
M8 Ø 8.8 steel screw on brass, copper, aluminium and their alloys	16
M8 Ø 8.8 steel screw Iron, steel	26
M10 Ø 8.8 steel screw Iron, steel	52
M12 Ø 8.8 steel screw Iron, steel	100
M14 Ø 8.8 steel screw Iron, steel	145

STEERING ASSEMBLY

Name	Torque in Nm
Upper steering ring nut	30 ÷ 40
Lower steering ring-nut	50 ÷ 60 (therefore to loosen by 90 ÷ 100)
Handlebars stud *	65 ÷ 70

FRAME ASSEMBLY

Name	Torque in Nm
Swinging arm - engine pin*	33 ÷ 41
Frame - swing arm bolt *	33 ÷ 41
Shock-absorber - frame nut *	20 ÷ 25
Shock-absorber - engine bolt *	33 ÷ 41
Wheel axle pin*	100 ÷ 125
Stand pin	18.5 ÷ 19
Stand screws	18.5 ÷ 19

*: safety torque

FRONT SUSPENSION

Name	Torque in Nm
Fork nut *	20 ÷ 25
Fork screw	20 ÷ 25
Front wheel axle *	45 ÷ 50

*: safety torque

FRONT BRAKE

Name	Torque in Nm
Brake fluid pump - hose fitting	13 to 18 Nm
Brake fluid pipe-calliper fitting	20 ÷ 25
Support calliper tightening screw*	20 ÷ 25
Front disc tightening screw*	12 ÷ 15
Oil bleed screw	7 to 10 Nm

*: safety torque

REAR BRAKE

Name	Torque in Nm
Calliper tightening screw	20 ÷ 25
Brake fluid tube- calliper	13 ÷ 18
Brake fluid pump - hose fitting	13 to 18 Nm
Disc tightening screw	6 ÷ 6.5
Rear wheel axle	100 ÷ 125
Rear wheel hub screw	20 ÷ 25
Oil bleed screw	7 to 10 Nm

N.B.

IN ORDER TO ENSURE AN ADEQUATE LOCKING TORQUE, LUBRICATE THE NUTS BEFORE ASSEMBLING THEM.

ENGINE ASSEMBLY

Name	Torque in Nm
Head tightening nut	10 ÷ 11
Coolant bleed screw	1 ÷ 2
Temperature sensor	6 ÷ 8
Temperature sensor at the ECU	18 ÷ 22
Crankcase closure screw	12 ÷ 13
Transmission cover closing screw	12 ÷ 13
Pick-up screw	3 ÷ 4
Stator screw	3 ÷ 4
Suction connection screw	7 ÷ 8
Starter screw	12 ÷ 13
Mixer screw	3 ÷ 5
Rear hub cap screw	12 ÷ 13
Driving pulley nut	40÷ 44*
Driven pulley nut	40÷ 44*
Oil drain rear hub screw	3 ÷ 5
Clutch nut	55 ÷ 60
Mixer strip screw	3 ÷ 4
Ignition spark plug	11 ÷ 14
Head union screw	3 ÷ 4
Flywheel cover screw	1 ÷ 2
Flywheel tightening nut	40÷ 44*
Transmission strip cap screw	3 ÷ 4
Transmission cooling cap screw	3 ÷ 4
Water pump rotor	0.5 ÷ 0.4
Muffler -cylinder nut	9 ÷ 11
Engine - muffler screw	22 ÷ 24
Fuel injector to the head studs	3 ÷ 4
Crankcase compressor studs	3 ÷ 4

* Use new nuts

Overhaul data**Assembly clearances**

Cylinder - piston assy.

CYLINDER-PISTON FITTING

Name	Initials	Cylinder	Piston	Play on fitting
Standard fitting	M	39.997-40.004	39.943-39.95	0.047-0.061
Standard fitting	N	40.004-40.011	39.95-39.957	0.047-0.061
Standard fitting	O	40.011-40.018	39.957-39.964	0.047-0.061
Standard fitting	P	40.018-40.025	39.964-39.971	0.047-0.061
1st oversize fitting	M1	40.197-40.204	40.143-40.15	0.047-0.061
1st oversize fitting	N1	40.204-40.211	40.15-40.157	0.047-0.061
1st oversize fitting	O1	40.211-40.218	40.157-40.164	0.047-0.061
1st oversize fitting	P1	40.218-40.225	40.164-40.171	0.047-0.061
2nd oversize fitting	M2	40.397-40.404	40.343-40.35	0.047-0.061
2nd oversize fitting	N2	40.404-40.411	40.35-40.357	0.047-0.061
2nd oversize fitting	O2	40.411-40.418	40.357-40.364	0.047-0.061
2nd oversize fitting	P2	40.418-40.425	40.364-40.371	0.047-0.061

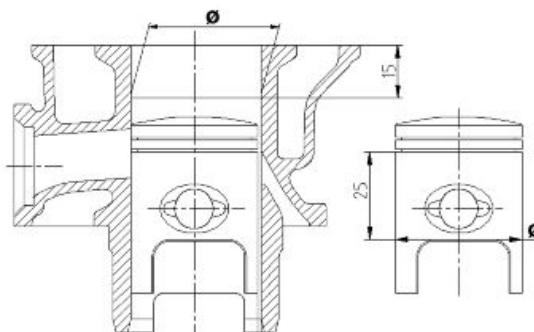

Piston rings

SEALING RINGS

Name	Description	Dimensions	Initials	Quantity
Compression ring		40	A	0.10 to 0.25
Compression ring 1st oversize		40.2	A	0.10 to 0.25
Compression ring 2nd Oversize		40.4	A	0.10 to 0.25

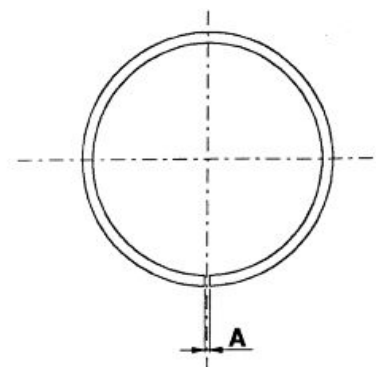

Crankcase - crankshaft - connecting rod

PISTON - TEST PROBE

Name	Description	Dimensions	Initials	Quantity
Piston		Ø 12 +0.007 +0.012	P	0.002 ÷ 0.011
Test probe		Ø 12 +0.005 +0.001	Q	0.002 ÷ 0.011

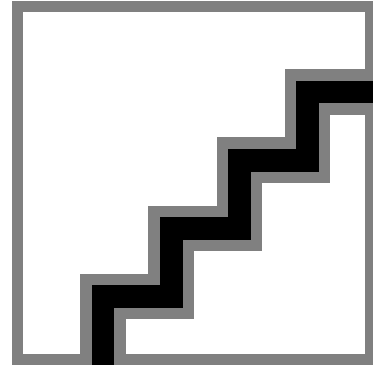

ROD SMALL END - ROLLER CASING - TEST PROBE

Name	Description	Dimensions	Initials	Quantity
Connecting rod		Ø 17 +0.011 0.001	G	0.002 ÷ 0.012
Roller casing		Ø 2.5 0 0.007	F	0.002 ÷ 0.012
Test probe		Ø 12 + 0.005 + 0.001	H	0.002 ÷ 0.012

FITTING CATEGORY ROD SMALL END - ROLLER CASING - TEST PROBE

Name	Description	Dimensions	Initials	Quantity
Rod small end	Cat. 3	Ø 17		+ 0.011 + 0.007
Rod small end	Cat. 2	Ø 17		+ 0.007 + 0.003
Rod small end	Cat. 1	Ø 17	+0.003 -0.001	
Roller casing	Cat. 1	Ø 2.5		0 -0.002
Roller casing	Cat. 2	Ø 2.5		-0.002 -0.004
Roller casing	Cat. 3	Ø 2.5		-0.004 -0.006
Roller casing	Cat. 1 Optional	Ø 2.5		-0.001 -0.003
Roller casing	Cat. 2 Optional	Ø 2.5		-0.003 -0.005
Roller casing	Cat. 3 Optional	Ø 2.5		-0.005 -0.007
Test probe				+0.005 +0.001

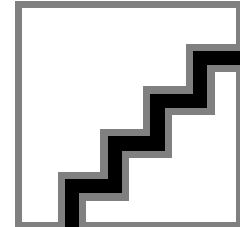

AXIAL PLAY CONNECTING ROD - CRANKSHAFT

Name	Description	Dimensions	Initials	Quantity
Connecting rod		11.75 0 -0.05	A	0.25 ÷ 0.50
Shoulder washer		0.5 ±0.03	G	0.25 ÷ 0.50
Semi-shaft, trans. side		13.75 +0.04 0	C	0.25 ÷ 0.50
Semi-shaft, flywheel side		13.75 +0.04 0	D	0.25 ÷ 0.50

Name	Description	Dimensions	Initials	Quantity
Spacer tool		40.64	H	0.25 ÷ 0.50
Casing		11.8 0 -0.35	B	0.20 ÷ 0.75
Shoulder washer		0.5 ±0.03	G	0.20 ÷ 0.75
Semi-shaft, trans. side		13.75 +0.04 0	C	0.20 ÷ 0.75
Semi-shaft, flywheel side		13.75 +0.04 0	D	0.20 ÷ 0.75
Spacer tool		40.64	H	0.20 ÷ 0.75

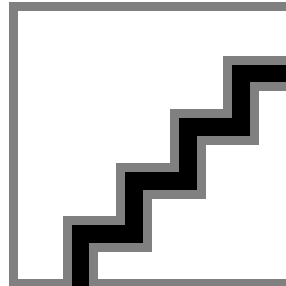

Slot packing system

Fit the cylinder without installing the gasket to the base.

Apply a centimetre dial gauge and reset it on an adjusted surface.

Fit the tool on the top of the cylinder fixing it with two nuts to the stud bolts, keeping to the torque wrench setting and take the piston to the dead centre position.

The thickness of the gasket to fit will change depending on the value found.

Three gaskets are given with the following thickness :

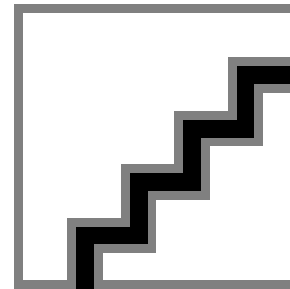

Specific tooling

020272Y Piston position check tool

Locking torques (N*m)

Locking head nuts: 10 ÷ 11 N.m

SHIMMING SYSTEM

Name	Measure A	Thickness
Shimming	2.80 ÷ 3.04	0,4
Shimming	3.04 ÷ 3.24	0,6
Shimming	3.25 ÷ 3.48	0,8

Products

TABLE OF RECOMMENDED PRODUCTS

Product	Description	Specifications
AGIP ROTRA 80W-90	Rear hub oil	SAE 80W/90 Oil that exceeds the requirements of API GL3 specifications
AGIP CITY HI TEC 4T	Oil for flexible transmission lubrication (acceleration control, mixer and odometer)	Synthetic oil that passes SAE 5W-40, API SL, ACEA A3, JASO MA specifications
AGIP CITY HI TEC 4T	Oil for air filter sponge	Synthetic oil that passes SAE 5W-40, API SL, ACEA A3, JASO MA specifications
AGIP GP 330	Grease for brake control levers, throttle, stand	White calcium complex soap-based spray grease with NLGI 2; ISO-L-XBCIB2
AGIP CITY TEC 2T	Mixer oil	synthetic oil for 2-stroke engines: JASO FC, ISO-L-EGD
AGIP GREASE MU3	Grease for odometer transmission gear case	Soap-based lithium grease with NLGI 3; ISO-L-XBCHA3, DIN K3K-20
AGIP BRAKE 4	Brake fluid	FMVSS DOT 4 Synthetic fluid
AGIP GREASE SM 2	Grease for compensating ring	NLGI 2; ISO-L-XBCHB2, DIN KF2K-20 Molybdenum disulphide grease and lithium soap
AGIP GREASE PV2	Grease for control levers on the engine	White anhydrous-calcium based grease to protect roller bearings; temperature range between -20 °C and +120 °C; NLGI 2; ISO-L-XBCIB2
AGIP PERMANENT PLUS	Coolant	Monoethylene glycol antifreeze fluid, CU-NA NC 956-16
AGIP GREASE SM 2	Greasing the driven pulley bushing	Soap-based lithium grease with NLGI 2 Molybdenum Disulphide; ISO-L-XBCHB2, DIN KF2K-20

INDEX OF TOPICS

TOOLING

TOOL

TOOLING

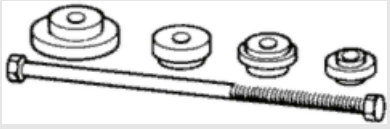
Stores code	Description	
001330Y	Tool for fitting steering seats	



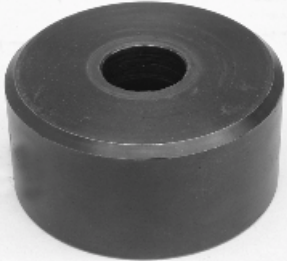



001467Y006	Pliers to extract 20 mm bearings	
------------	----------------------------------	---

001467Y007	Driver for OD 54 mm bearing	
------------	-----------------------------	--

001467Y009	Driver for OD 42-mm bearings	
------------	------------------------------	---





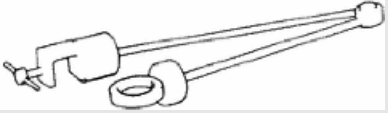

001467Y013	Pliers to extract ø 15-mm bearings	
------------	------------------------------------	--





001467Y014	Pliers to extract ø 15-mm bearings	
------------	------------------------------------	--

Stores code	Description	
001467Y017	Bell for bearings, OD 39 mm	
001467Y021	Extraction pliers for ø 11 mm bearings	
002465Y	Pliers for circlips	
006029Y	Punch for fitting fifth wheel seat on steering tube	
020004Y	Punch for removing fifth wheels from headstock	
020209Y	Spring hook	

Stores code	Description	
020055Y	Wrench for steering tube ring nut	
020074Y	Support base for checking crankshaft alignment	
020150Y	Air heater support	
020151Y	Air heater	
020162Y	Flywheel extractor	
020163Y	Crankcase splitting plate	

Stores code	Description	
020164Y	Driven pulley assembly sheath	
020165Y	Start-up crown lock	
020166Y	Pin lock fitting tool	
020167Y	Arrest key for impeller pump	
020168Y	Water seal punch mount on half-crank-case	
020169Y	Water pump crankshaft fitting and removal spanner	

Stores code	Description	
020170Y	Water pump/mixer command gear extractor	
020261Y	Starter spring fitting	
020262Y	Crankcase splitting strip	
020265Y	Bearing fitting base	
020325Y	Brake-shoe spring calliper	
020329Y	MityVac vacuum-operated pump	

Stores code	Description	
020330Y	Stroboscopic light to check timing	 A handheld stroboscopic light tool with a grey body and a black handle, connected to a black power cord.
020331Y	Digital multimeter	 A digital multimeter with a white face and black casing, featuring a large LCD display and several control buttons, with two test leads attached.
020332Y	Digital rev counter	 A black handheld digital rev counter with a small LCD screen and a single test lead attached.
020334Y	Multiple battery charger	 A large, grey, rectangular multiple battery charger with a complex control panel featuring numerous buttons, switches, and a digital display.

Stores code	Description	
020335Y	Magnetic support for dial gauge	





020350Y	Electrical system check instrument	
---------	------------------------------------	---

020357Y	32 x 35 mm adaptor	
020359Y	42x47-mm adaptor	

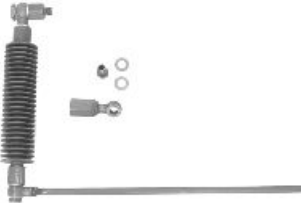

020376Y	Adaptor handle	
---------	----------------	--

020412Y	15 mm guide	
---------	-------------	---

Stores code	Description	
020456Y	Ø 24 mm adaptor	
020483Y	30 mm guide	
020565Y	Flywheel lock calliper spanner	
020625Y	Kit for sampling gas from the exhaust manifold	
494929Y	Exhaust fumes analyser	

INDEX OF TOPICS

MAINTENANCE

MAIN

Maintenance chart

EVERY 2 YEARS

Action

- Brake fluid - change
- Coolant - change

AT 1000 KM OR 4 MONTHS

50'

Action

- Hub oil - change
- Oil mixer/throttle linkage - adjustment
- Steering - adjustment
- Brake control levers - greasing
- Coolant level - check
- Brake fluid level - check
- Safety locks - check
- Electrical system and battery - check
- Tyre pressure and wear - check
- Vehicle and brake test - road test

AT 5000 KM OR 12 MONTHS, 25000 KM, 35000 KM AND 55000 KM

40'

Action

- Hub oil level - check
- Spark plug/electrode gap - replacement
- Air filter - clean
- Oil mixer/throttle linkage - adjustment
- Coolant level - check
- Brake control levers - greasing
- Brake pads - check condition and wear
- Brake fluid level - check
- Electrical system and battery - check
- Tyre pressure and wear - check
- Vehicle and brake test - road test

AT 10000 KM OR 24 MONTHS AND 50000 KM

95'

Action

- Hub oil - change
- Spark plug/electrode gap - replacement
- Air filter - clean
- Idle speed (*) - adjustment
- Oil mixer/throttle linkage - adjustment
- Variable speed rollers - replacement
- Driving belt - checking
- Coolant level - check
- Steering - adjustment
- Brake control levers - greasing
- Brake pads - check condition and wear
- Brake fluid level - check
- Transmission elements - lubrication
- Safety locks - check
- Suspensions - check
- Electrical system and battery - check
- Headlight - adjustment
- Tyre pressure and wear - check
- Vehicle and brake test - road test

(*) see the section "Idle adjustment"

AT 15000 KM AND 45000 KM

65'

Action

Hub oil level - check
Spark plug/electrode gap - replacement
Air filter - cleaning
Oil mixer/throttle linkage - adjustment
Driving belt - replacement
Coolant level - check
Brake control levers - greasing
Brake pads - check condition and wear
Brake fluid level - check
Electrical system and battery - check
Tyre pressure and wear - check
SAS box (sponge) (**) - cleaning
Vehicle and brake test - road test

(**) See the regulations of the "Secondary air system" section

AT 20000 KM AND 40000 KM

120'

Action

Hub oil - change
Spark plug/electrode gap - replacement
Air filter - clean
Idling speed (*) - adjustment
Cylinder cooling system - check/cleaning
Oil mixer/throttle linkage - adjustment
Driving belt - checking
Variable speed rollers - replacement
Mixer belt - replacement
Coolant level - check
Radiator - external cleaning/ check
Steering - adjustment
Brake control levers - greasing
Brake pads - check condition and wear
Brake fluid level - check
Transmission elements - lubrication
Safety locks - check
Suspensions - check
Electrical system and battery - check
Headlight - adjustment
Tyre pressure and wear - check
Vehicle and brake test - road test

(*) See the section "Idle adjustment"

AT 30000 KM

130'

Action

Hub oil - change
Spark plug/electrode gap - replacement
Air filter - clean
Idling speed (*) - adjustment
Oil mixer/throttle linkage - adjustment
Driving belt - replacement
Variable speed rollers - replacement
Coolant level - check
Steering - adjustment
Brake control levers - greasing
Brake pads - check condition and wear
Flexible brake tubes - replacement
Brake fluid level - check
Transmission elements - lubrication

Action

Safety locks - check
Suspensions - check
Electrical system and battery - check
Headlight - adjustment
Tyre pressure and wear - check
SAS box (sponge) (**) - cleaning
Vehicle and brake test - road test

(**) See the regulations of the "Secondary air system" section

AT 60000 KM

160'

Action

Hub oil - change
Spark plug/electrode gap - replacement
Air filter - clean
Idling speed (*) - adjustment
Oil mixer/throttle linkage - adjustment
Driving belt - replacement
Variable speed rollers - replacement
Mixer belt - replacement
Coolant level - check
Radiator - external cleaning/ check
Odometer gear - greasing
Steering - adjustment
Brake control levers - greasing
Brake pads - check condition and wear
Flexible brake tubes - replacement
Brake fluid level - check
Transmission elements - lubrication
Safety locks - check
Suspensions - check
Electrical system and battery - check
Headlight - adjustment
Tyre pressure and wear - check
SAS box (sponge) (**) - cleaning
Vehicle and brake test - road test

(**) See the regulations of the "Secondary air system" section

Checking the spark advance

- Check to made at a regime over 4000 rpm with stroboscopic gun. The advance measured must be 16° before the dead centre position.
- Before checking, remove the rubber cap shown in the figure; this makes it possible to view a fixed reference on the flywheel cover

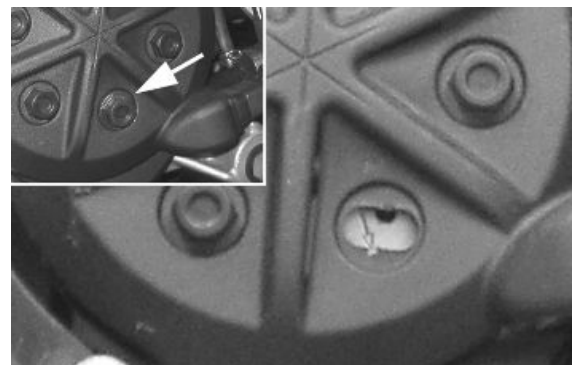

N.B.

IN CASE OF MALFUNCTION, CARRY OUT THE CHECKS PROVIDED FOR IN THE ELECTRICAL SYSTEM CHAPTER.

CAUTION

BEFORE CARRYING OUT THE ABOVE CHECKS, CHECK THE CORRECT KEYING OF THE FLYWHEEL ON THE CRANKSHAFT.

Specific tooling

020330Y Stroboscopic light to check timing

Spark plug

- Remove one of the two side panels of the footboard, unscrewing the four studs, one of which is under the passenger footboard;
 - Disconnect the cap of the H.V. coil of the spark plug;
 - Unscrew the spark plug using a socket wrench;
 - Check the conditions of the spark plug and the insulation and measure the distance between the electrodes with a feeler gauge.
 - Proceed with regulating the distance by folding the side electrode carefully.
- In case of defect, replace the spark plug with one of the prescribed types;
- Insert the sparkplug with the correct inclination, screwing it all the way in, then tighten it with the specific wrench to the correct torque;
 - Insert the cap onto the spark plug;
 - Refit the central door.

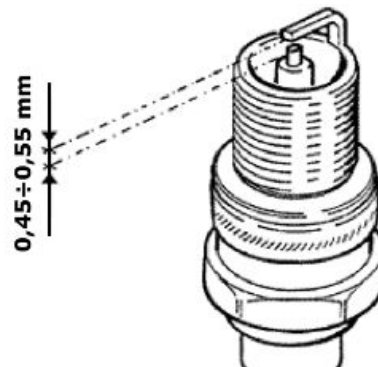

CAUTION

THE SPARK PLUG MUST BE REMOVED WHEN THE MOTOR IS COLD. THE SPARK PLUG MUST BE REPLACED EVERY 5000 KM. USE OF STARTERS NOT CONFORMING OR SPARK PLUGS NOT THOSE DESCRIBED CAN SERIOUSLY DAMAGE THE ENGINE.

Characteristic

Spark plug

CHAMPION RN1C

Electric characteristic

Electrode gap

0.45 ÷ 0.55 mm

Locking torques (N*m)

Spark plug 25 - 30 Nm

Hub oil

Check

To check the level of oil in the hub, proceed as follows:

1. Bring the vehicle to a flat surface and place it on the stand;
2. Remove the dipstick "A" dry it on a clean cloth, the reinsert it, **screwing it in all the way**;
3. Remove the dipstick again, checking that the oil level reaches **the second notch from the bottom**;
4. Screw the dipstick back in, checking that it is locked in plac
5. e;

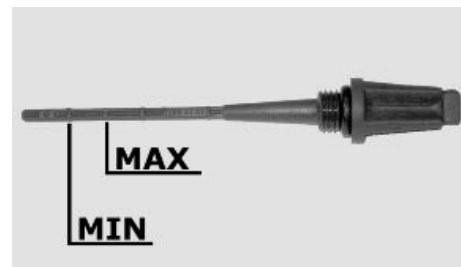
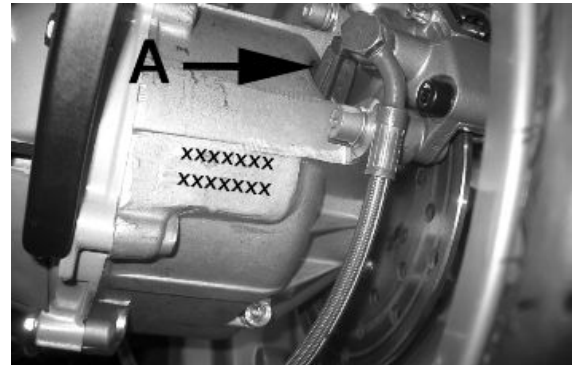

CAUTION



USING THE ENGINE WITH INSUFFICIENT LUBRICATION OR WITH THE WRONG LUBRICANTS MAY INCREASE WEAR AND TEAR ON THE MOVING PARTS AND MAY CAUSE SERIOUS DAMAGE.

CAUTION



USED OILS CONTAIN SUBSTANCES HARMFUL TO THE ENVIRONMENT. FOR OIL REPLACEMENT, CONTACT AN AUTHORISED SERVICE CENTRE, WHICH IS EQUIPPED TO DISPOSE OF USED OILS IN AN ENVIRONMENTALLY FRIENDLY AND LEGAL WAY.

N.B.

THE NOTCHES ON THE HUB OIL LEVEL DIPSTICK, EXCEPT THOSE INDICATING THE MAXIMUM AND MINIMUM LEVELS, REFER TO OTHER MODELS BY THE MANUFACTURER, AND HAVE NO SPECIFIC FUNCTION FOR THIS MODEL.

Recommended products

AGIP ROTRA 80W-90 Rear hub oil

SAE 80W/90 Oil that exceeds the requirements of API GL3 specifications

Characteristic

Rear hub oil

Quantity: approx. 75 cm³

Replacement

- Remove the oil cap «A».
- Unscrew the oil cap «B» and drain out all the oil.
- Screw the cap back on and fill up the hub with the required oil.

Characteristic

Rear hub oil

Quantity: approx. 75 cm³

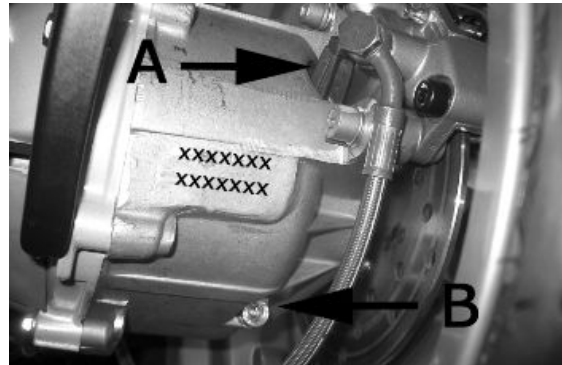

Air filter

- Remove the cap of the purifier, unscrewing the six clamping screws and removing the filter.

Cleaning:

- Wash with water and neutral soap.
- Dry with a clean cloth and short blasts of compressed air.
- Saturate with a 50% mixture of gasoline and oil.
- Drip dry the filter and then squeeze it between the hands without wringing.
- Let it dry and refit it again.



CAUTION

NEVER RUN THE ENGINE WITHOUT THE AIR FILTER, THIS WOULD RESULT IN AN EXCESSIVE WEAR OF THE PISTON AND CYLINDER.

Recommended products

AGIP FILTER OIL Oil for air filter sponge

Mineral oil with specific additives for increased adhesiveness

transmissions

During this phase, the engine must be powered with a 2% blend (at least 0.5 litres if the tank is empty).

Remove the crankcase of the carburettor cover. Start the vehicle and adjust the idle using the adjustment screw **A** on the carburettor. Adjust the control wires. Adjust the control wires:

Knob command: remove the rubber cap and adjust the wire so that there is no play on the gas knob.

Command to the carburettor: remove the rubber cap and adjust the wire so that there is no play on the sleeve.

Command to the mixer: remove the cap on the crankcase and adjust the wire so that when the gas knob is released, the reference on the rotating plate is aligned with reference made on the mixer body, as shown in the figure.

Turn the gas knob to the end stop a couple of times and check that the regulations are done correctly, then tighten all the adjustments.

N.B.

TO VERIFY THE CORRECT TIMING OF THE MIXER IT IS NECESSARY TO REMOVE THE AIR CONDUIT OF THE TRANSMISSION COVER.

CAUTION

IN CASE OF DISMANTLING OR RUNNING OUT OF OIL IN THE RESERVOIR BLEED THE MIXER AS FOLLOWS: REFILL THE OIL RESERVOIR WHEN THE MIXER IS FITTED TO THE VEHICLE AND THE ENGINE IS OFF, UNDO THE MIXER PIPE FROM THE CARBURETTOR AND LOOSEN THE BLEED SCREWS (SEE THE ARROW IN THE FIGURE) UNTIL THE OIL BEGINS TO FLOW OUT. TIGHTEN THE SCREWS, START UP THE ENGINE AND WAIT FOR OIL TO FLOW OUT OF THE TUBE. RECONNECT THE DELIVERY PIPE TO THE CARBURETTOR AND FIX IT IN PLACE WITH THE RELEVANT METAL CLIP.

Recommended products

AGIP CITY TEC 2T Mixer oil

synthetic oil for 2-stroke engines: JASO FC, ISO-L-EGD

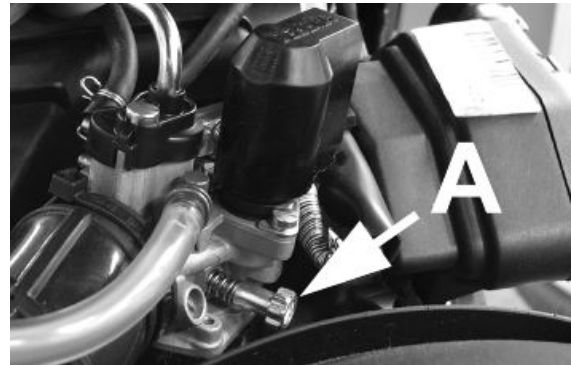

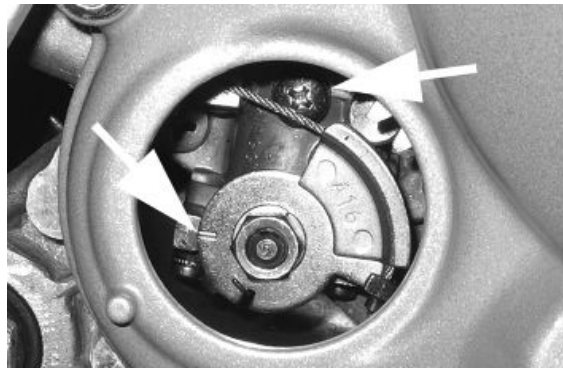

Cooling system

Level check

- Remove the front grille
 - Check that the coolant level is between the min and max reference marks.
- Top up with recommended coolant, if necessary.

Recommended products

AGIP PERMANENT PLUS Coolant

Monoethylene glycol antifreeze fluid, CUNA NC 956-16

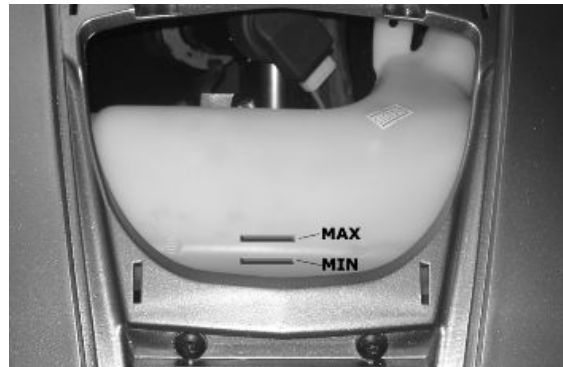

Braking system

Level check

Proceed as follows:

- Rest the vehicle on its centre stand with the handlebars perfectly horizontal;
- Check the level of liquid with the related warning light «A».

A certain lowering of the level is caused by wear on the pads.

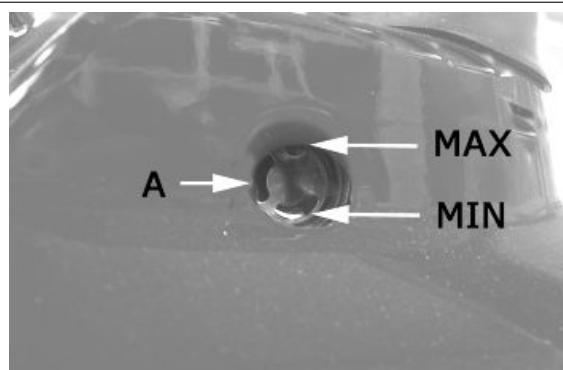

Top-up

Proceed as follows:

1. rest the vehicle on its centre stand with the handlebars perfectly horizontal;
2. remove the rear-view mirrors;
3. remove the front handlebar cover;
4. remove the tank cover «A» loosening the two fixing screws «B» and restore the level using only the prescribed fluid without exceeding the maximum level.

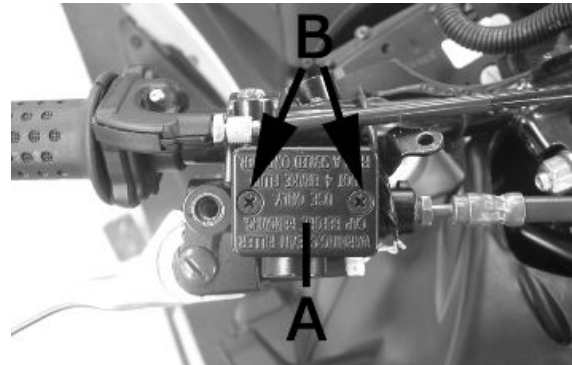

Under normal climatic conditions, the liquid should be replaced every two years. This operation must be carried out by trained technicians, please contact an **Authorised Piaggio-Gilera Service Centre**

CAUTION



TOP UPS SHOULD ONLY BE CARRIED OUT WITH DOT 4 CLASSIFIED BRAKE FLUID.

CAUTION



THE BRAKING CIRCUIT FLUID IS HIGHLY CORROSIVE. THEREFORE, WHEN TOPPING IT UP, AVOID LETTING IT COME INTO CONTACT WITH THE PAINTED PARTS OF THE VEHICLE. THE BRAKING CIRCUIT FLUID IS HYGROSCOPIC, THAT IS, IT ABSORBS HUMIDITY FROM THE SURROUNDING AIR. IF MOISTURE CONTAINED IN THE BRAKE FLUID EXCEEDS A CERTAIN VALUE, THIS WILL RESULT IN INEFFICIENT BRAKING.

WARNING



IN NORMAL CLIMATIC CONDITIONS IT IS ADVISABLE TO REPLACE THE ABOVE-MENTIONED FLUID EVERY 2 YEAR. NEVER USE BRAKE FLUID CONTAINED IN CONTAINERS WHICH ARE ALREADY OPEN OR PARTIALLY USED.

Recommended products

AGIP BRAKE 4 Brake fluid

FMVSS DOT 4 Synthetic fluid

Headlight adjustment

Proceed as follows:

1. Place the vehicle in running order and with the tyres inflated to the prescribed pressure, on a flat surface 10 m away from a white screen situated in a shaded area, making sure that the longitudinal axis of the vehicle is perpendicular to the screen;
2. Turn on the headlight and check that the borderline of the projected light beam on the screen is not lower than $\frac{9}{10}$ of the distance from the ground to the centre of vehicle headlamp and higher than $\frac{7}{10}$;
3. Otherwise, regulate the headlight by adjusting the screw «A», after removing the front grille.

N.B.

THE ABOVE PROCEDURE COMPLIES WITH THE EUROPEAN STANDARDS REGARDING MAXIMUM AND MINIMUM HEIGHT OF LIGHT BEAMS. REFER TO THE STATUTORY REGULATIONS IN FORCE IN EVERY COUNTRY WHERE THE vehicle IS USED.

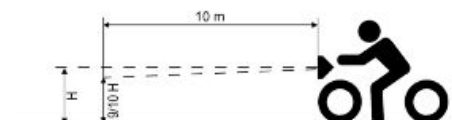
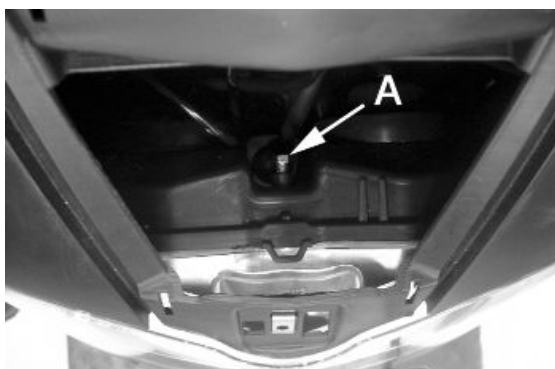

INDEX OF TOPICS

TROUBLESHOOTING

TROUBL

This section makes it possible to find the solutions to use in troubleshooting.

For each breakdown, a list of the possible causes and respective interventions is given.

Engine

Poor performance

POOR PERFORMANCE

Possible Cause	Operation
Defective fuel pump or damaged depression line	Replace the pump or control lines
Carburettor nozzles clogged or dirty	Dismantle, wash with solvent and dry with compressed air
Fuel filter on the tank outlet fitting dirty or clogged	Clean the fitting filter
Excess of encrustations in the combustion chamber	Remove the encrustations
Lack of compression wear of the piston rings or cylinder	Check the worn parts and replace them
Exhaust pipe clogged due to excessive encrustations	Replace the exhaust pipe and check the carburation and mixer timer
Air filter blocked or dirty	Clean according to the procedure
Starter inefficient (stays on)	Check the mechanical sliding, continuity of the circuit, the presence of power and electrical wiring
Clutch slipping	Check the centrifugal brake shoe assembly and /or clutch bell and replace if necessary
Defective mobile pulley sliding	Check the parts, change the faulty parts and lubricate the driven pulley using only Montblanc-Molibdenum Grease (dis. 498345) grease
Transmission belt worn	Replace
Roller wear; Presence of oil; Dirt	Clean the speed variator, replace the rollers if worn out

Rear wheel spins at idle

REAR WHEEL

Possible Cause	Operation
Idling rpms too high	Check the idling speed and, if necessary, adjust the C.O.
Clutch fault	Check the spring/friction mass and the clutch bell
Air filter housing not sealed	Correctly refit the filter housing and replace it if it is damaged

Starting difficulties

DIFFICULTY STARTING

Possible Cause	Operation
Carburettor nozzles clogged or dirty	Dismantle, wash with solvent and dry with compressed air
Defective fuel pump or damaged depression line	Replace the pump or control lines
Starter inefficient	Check: electric wiring, circuit continuity, mechanical sliding and power supply
Battery flat	Check the state of the battery. If it shows signs of sulphation replace it and bring the new battery into service charging it for eight hours at a current of 1/10 of the capacity of the battery itself
- Engine flooded.	Start up keeping the throttle fully open alternating approximately five seconds of turning it with five seconds still. If however it does not start, remove the spark plug, the engine over with the throttle open being careful to keep the cap in contact with the spark plug and the spark plug grounded but away from its hole. Refit a dry spark plug and start the vehicle.
Altered fuel characteristics	Drain off the fuel no longer up to standard; then, refill
Defective spark plug or with incorrect electrode gap	Remove the encrustation, restore the plug gap or replace being sure to use the types of spark plug recommended at all times.

Possible Cause	Operation
	Bear in mind that many problems engines have, derive from the use of the wrong spark plug
Intake joint cracked or with a bad seal	Replace the intake joint and check its tightness on the crankcase and on the carburettor
Purifier-carburettor fitting damaged	Replace

Excessive oil consumption/Exhaust smoke

EXCESSIVE OIL CONSUMPTION/SMOKEY EXHAUST

Possible Cause	Operation
Excess of encrustations in the combustion chamber	Remove the encrustations

Engine tends to cut-off at full throttle

ENGINE STOP FULL THROTTLE

Possible Cause	Operation
Maximum nozzle dirty - lean mixture	Wash the nozzle with solvent and dry with compressed air
Dirty carburettor	Wash the carburettor with solvent and dry with compressed air
Water in the carburettor	Empty the tank through the appropriate bleed nipple.
Air filter dirty	Clean or replace
Defective floating valve	Check the proper sliding of the float and the functioning of the valve
Tank breather hole obstructed	Restore the proper tank aeration

Engine tends to cut-off at idle

ENGINE STOP IDLING

Possible Cause	Operation
Minimum nozzle dirty	Wash the nozzle with solvent and dry with compressed air
Starter that stays open	Check: electric wiring, circuit continuity, mechanical sliding and power supply
Reed valve does not close	Check / replace the reed pack
Wrong idling adjustment	Correctly adjust the engine idling and check the level of the C.O.
Spark plug defective or faulty	Replace the spark plug with one with the specified degree and check the plug gap

Excessive exhaust noise

INCREASED NOISINESS

Possible Cause	Operation
Secondary metal air pipe deteriorated	Check the seal of the piping on the crankcase and on the housing, check the piping between the housing and the muffler.
Good condition of the missing secondary air circuit components	Check the individual components and the piping, check the precision of the fitting. Replace the damaged components

High fuel consumption

HIGH FUEL CONSUMPTION

Possible Cause	Operation
Air filter blocked or dirty.	Clean according to the procedure

Possible Cause

Operation

Starter inefficient

Check: electric wiring, circuit continuity, mechanical sliding and power supply

Engine overheating

ENGINE OVERHEATING

Possible Cause

Operation

Lack of liquid in the cooling circuit.

Restore the level and check the absence of losses from the circuit

Incorrect air bleeding

Repeat the operation

Thermostat remains closed

Replace

Liquid leak from the radiator

Replace radiator

Liquid leak from the system

Overhaul of the system

Coolant leaks from crankcase draining hole

Replace coolant sealing ring on half-crankcase from transmission-side

Bearings shaft support impeller blocked

Replace the bearings and the shaft with impeller

Breakage of mixer belt

Replace the belt and check that the thermal unit has not been damaged

SAS malfunctions

SLACKENING OF THE RUBBER JOINT OF THE SECONDARY AIR PIPE ON THE MUFFLER

Possible Cause

Operation

Secondary air reed blocking

Replace

Secondary air filter clogging

Clean the filter and the housing

Blockage of the secondary air fitting on the muffler

Remove the encrustations from the joint being careful not to let the debris fall into the muffler

Transmission and brakes

Clutch grabbing or performing inadequately

CLUTCH

Possible Cause

Operation

Tear or irregular functioning

Check that the masses open and return normally
 Check that there is no grease on the masses
 Check that the clutch masses' contact surface with the clutch bell is mainly in the middle with characteristics equivalent on the three masses
 Check that the clutch bell is not scored or worn abnormally
 Never operate the engine without the clutch bell

Insufficient braking

INSUFFICIENT BRAKING

Possible Cause

Operation

Inefficient braking system

Check the pad wear (1.5 min). Check that the brake discs are not worn, scored or warped. Check the correct level of fluid in the pumps and change brake fluid if necessary. Check there is

Possible Cause	Operation
Fluid leakage in hydraulic braking system	no air in the circuits; if necessary, bleed the air. Check that the front brake calliper moves in axis with the disc. Failing elastic fittings, plunger or brake pump seals, replace

Brakes overheating

OVERHEATING BRAKES

Possible Cause	Operation
Brake disc slack or distorted	Check the brake disc screws are locked; use a dial gauge and a wheel mounted on the vehicle to measure the axial shift of the disc.
Defective piston sliding	Check calliper and replace any damaged part.

Electrical system

Battery

BATTERY

Possible Cause	Operation
Battery	The battery is the electrical device in the system that requires the most frequent inspections and thorough maintenance. If the vehicle is not used for some time (1 month or more) the battery needs to be recharged periodically. The battery runs down completely in the course of 5 ÷ 6 months. If the battery is fitted on a motorcycle, be careful not to invert the connections, keeping in mind that the black ground wire is connected to the negative terminal while the red wire is connected to the terminal marked+. Follow the instructions in the ELECTRICAL SYSTEM chapter for the recharging of the batteries.

Steering and suspensions

Rear wheel

POOR ROAD HOLDING

Possible Cause	Operation
Faulty suspension	Check that the rear shock absorber and/or the front fork is/are in good working order. Replace or overhaul the front fork and/or replace the rear shock absorbers in case of malfunction
Tyres deflated or damaged	Check the correct pressure of the tyres and the condition of the tread. Inflate to the correct pressure or replace.
Loosen the anchorage points of the front and/or rear suspension unit.	Check the tightness between the frame, swinging arm and engine and the fixing of the wheels to the hub and/or the axle. Check the correct tightening of the steering ring nut.

Heavy steering

STEERING HARDENING

Possible Cause	Operation
Torque not conforming	Check the tightening of the top and bottom ring nuts.

Possible Cause	Operation
	If irregularities continue in turning the steering even after making the above adjustments, check the seats in which the ball bearings rotate: replace if they are recessed.

Excessive steering play

EXCESSIVE STEERING CLEARANCE

Possible Cause	Operation
EXCESSIVE STEERING CLEARANCE	Check the tightening of the top and bottom ring nuts. If irregularities continue in turning the steering even after making the above adjustments, check the seats in which the ball bearings rotate: replace if they are recessed.

Noisy suspension

NOISY SUSPENSION

Possible Cause	Operation
Components of the front suspension damaged.	Check the quiet operation in the compression or release phases of the fork and if necessary overhaul it. Check that there is no noise or seizing during the wheel rotation; if there is, change the wheel bearing.
Components of the rear suspension damaged.	Check the absence of noise in the compression or release of the suspension, if necessary check the proper tightness to the swinging arm unit and the absence of rust or replace the entire shock absorber. Check that there is no noise or seizing during the wheel rotation; if there is noise or seizing overhaul the final reduction assembly.

Suspension oil leakage

SUSPENSION LEAKS OIL

Possible Cause	Operation
Rear shock absorption malfunctioning	Replace the complete shock absorption unit
Hydraulic cartridge in the fork damaged.	Replace the hydraulic cartridge

INDEX OF TOPICS

ELECTRICAL SYSTEM

ELE SYS

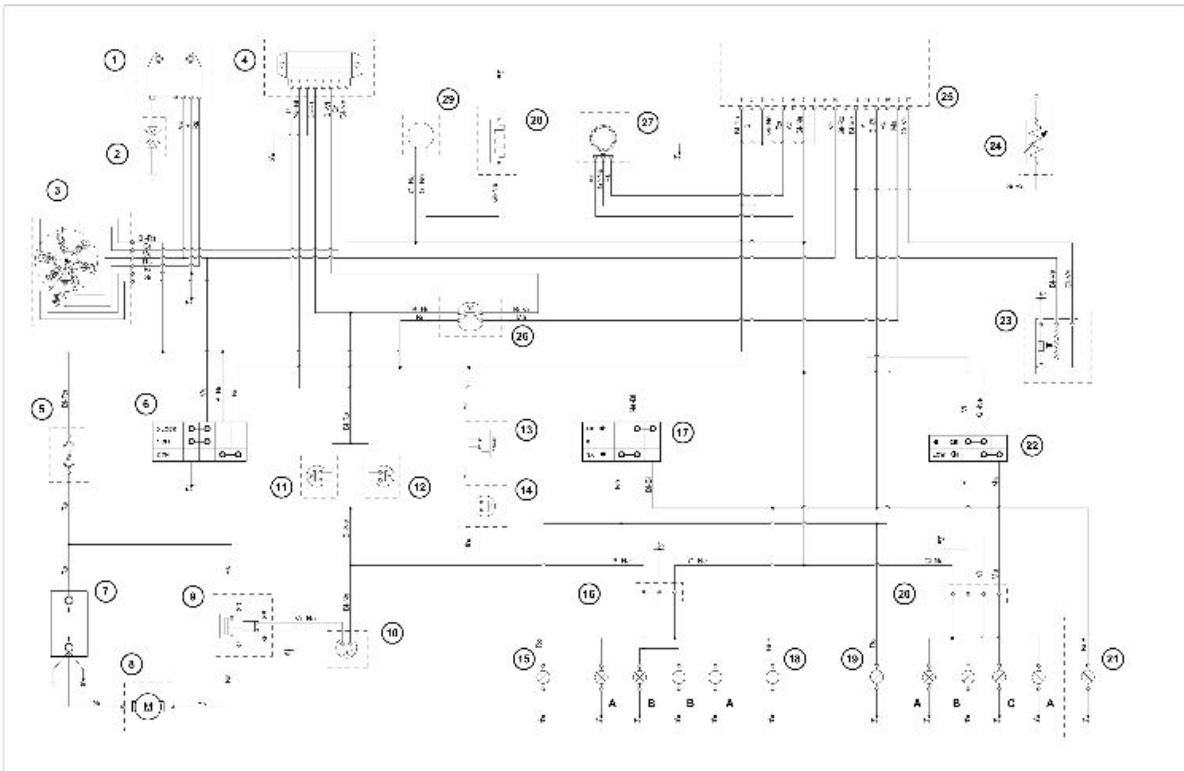

1. Electronic ignition device
2. Spark plug
3. Flywheel magneto
4. Voltage regulator
5. Main fuse 7.5 A
6. Key switch
7. Battery
8. Starter
9. Remote control ignition
10. Ignition switch
11. STOP button on rear brake
12. STOP button on front brake
13. Horn
14. Horn button
15. Left rear direction indicator light
16. Rear optical unit
 - A. Parking light
 - B. Stop light
17. Turn indicator switch
18. Right rear direction indicator light

- 19. Left front direction indicator light
- 20. Front optical unit
 - A. Parking light
 - B. High-beam headlight
 - C. Low-beam headlight
- 21. Right front direction indicator light
- 22. Light switch
- 23. Fuel level transmitter
- 24. Water temperature probe
- 25. Instruments unit
- 26. Oil control light
- 27. Phonic wheel
- 28. Automatic starter
- 29. Starter control light

Key

Ar: Orange **Az:** Sky blue **Bi:** White **Bl:** Blue **Gi:** Yellow **Gr:** Grey

Ma: Brown **Ne:** Black **Ro:** Pink **Rs:** Red **Ve:** Green **Vi:** Purple

Conceptual diagrams

Ignition

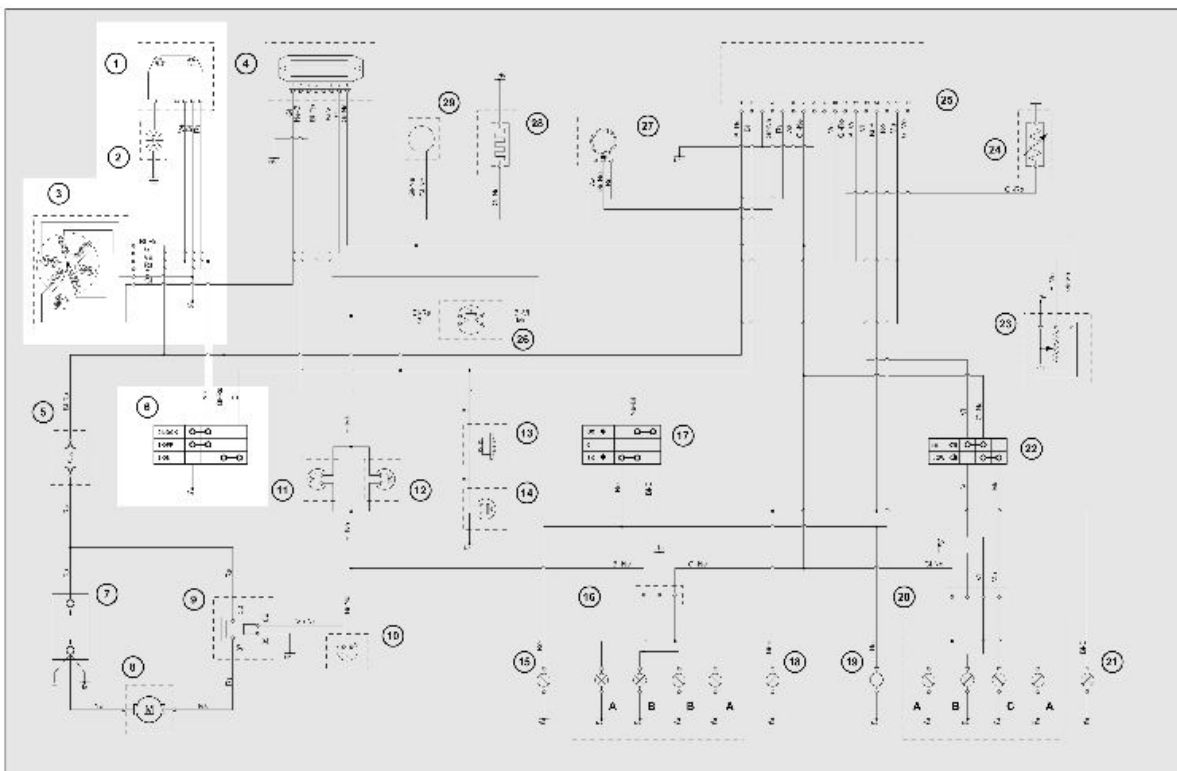

IGNITION

1. Electronic ignition device
2. Spark plug
3. Flywheel magneto
- 6 Key switch

Headlights and automatic starter section

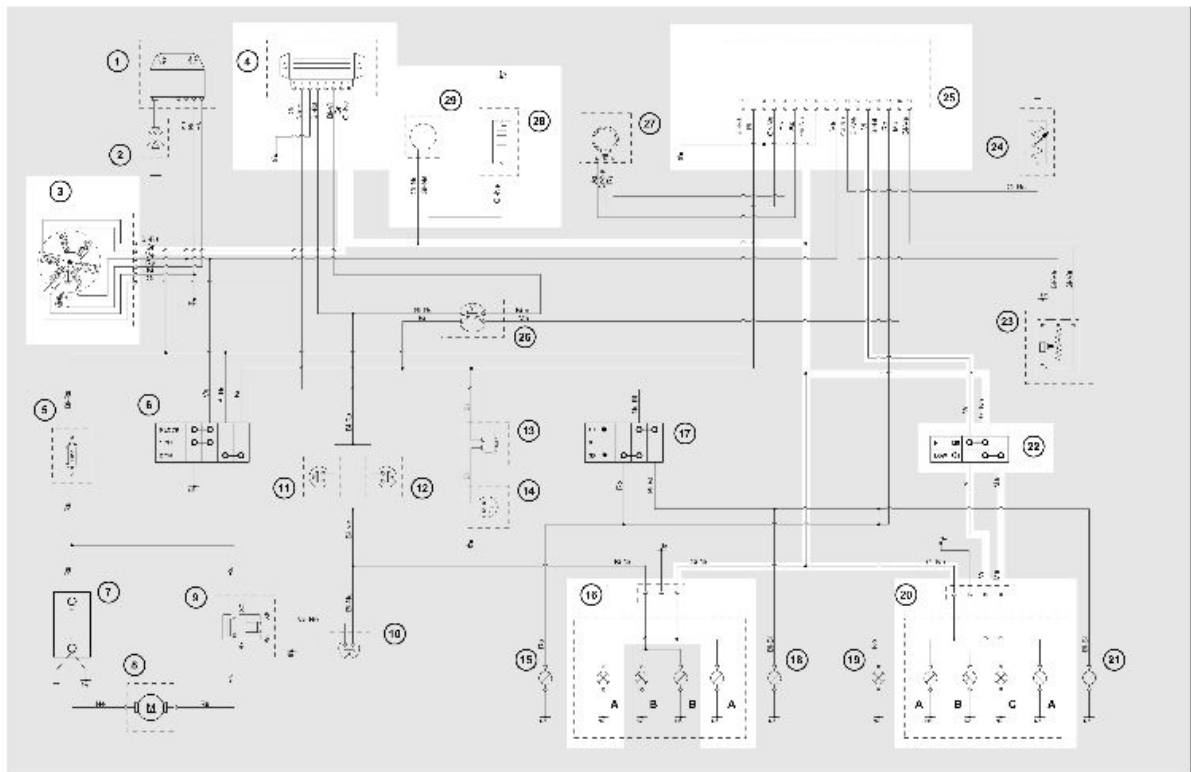

LIGHTS

- 3. Flywheel magneto
- 4 Voltage regulator
- 16. Rear optical unit
 - A. Parking light
 - B. Stop light
- 20. Front optical unit
 - A. Parking light
 - B. High-beam headlight
 - C. Low-beam headlight
- 22. Light switch
- 25. Instruments unit
- 28. Automatic starter
- 29. Starter control light

Battery recharge and starting

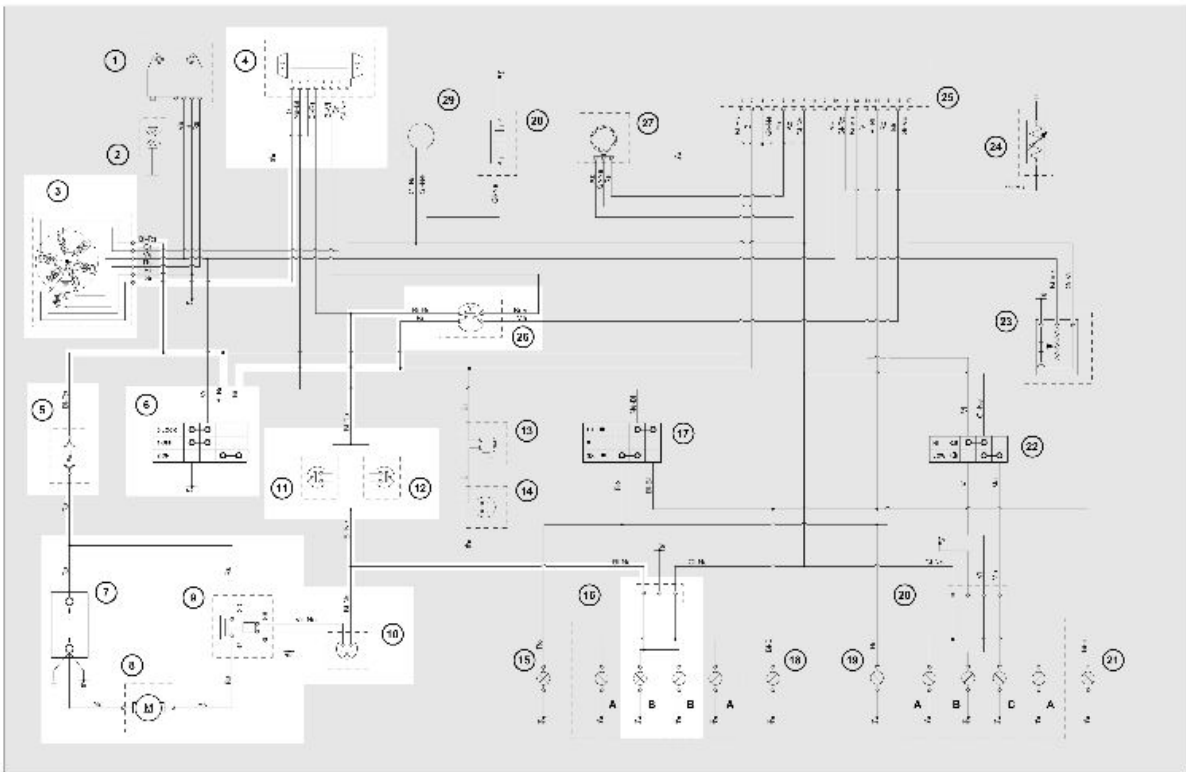

BATTERY CHARGER AND STARTER

- 3. Flywheel magneto
- 4 Voltage regulator
- 5. Main fuse 7.5 A
- 6 Key switch
- 7. Battery
- 8. Starter
- 9. Remote control ignition
- 10. Ignition switch
- 11. STOP button on rear brake
- 12. STOP button on front brake
- 16. Rear optical unit
- A. Parking light
- B. Stop light
- 26. Oil control light

Level indicators and enable signals section

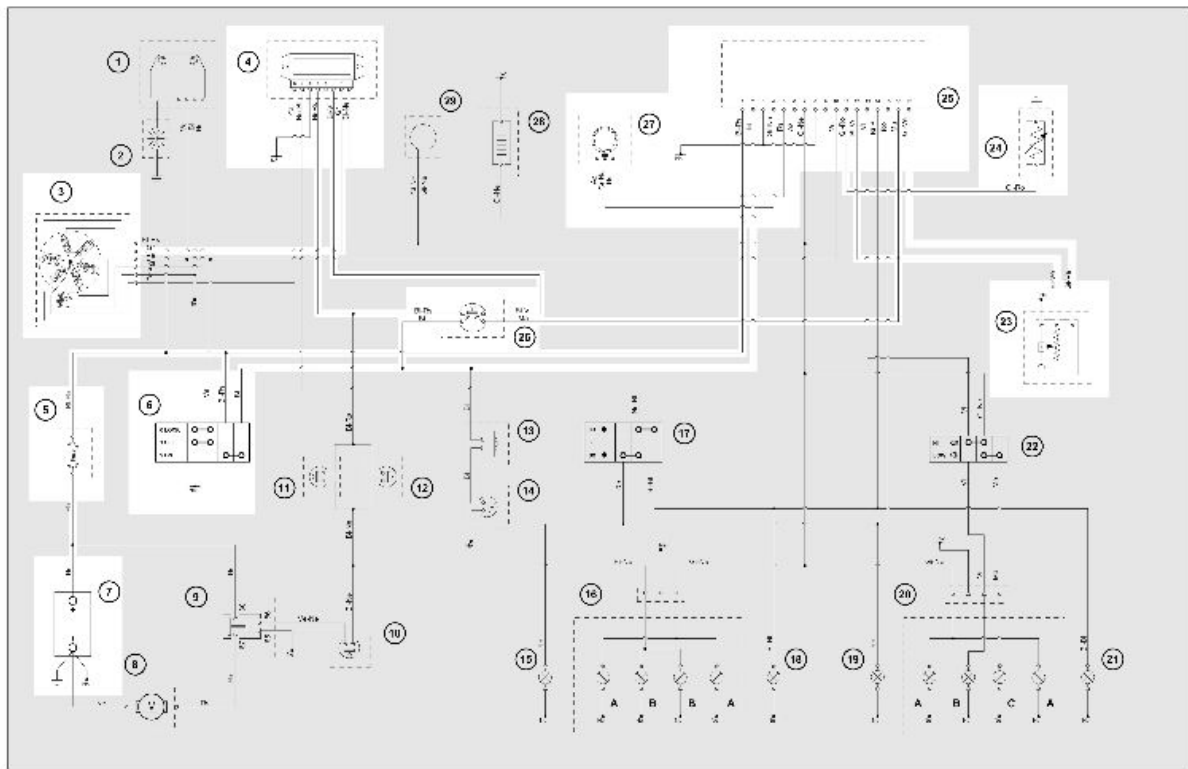

CONSENSUS AND LEVEL INDICATOR

- 3. Flywheel magneto
- 4 Voltage regulator
- 5. Main fuse 7.5 A
- 6 Key switch
- 7. Battery
- 23. Fuel level transmitter
- 24. Water temperature probe
- 25. Instruments unit
- 26. Oil control light
- 27. Phonic wheel

Turn signal lights

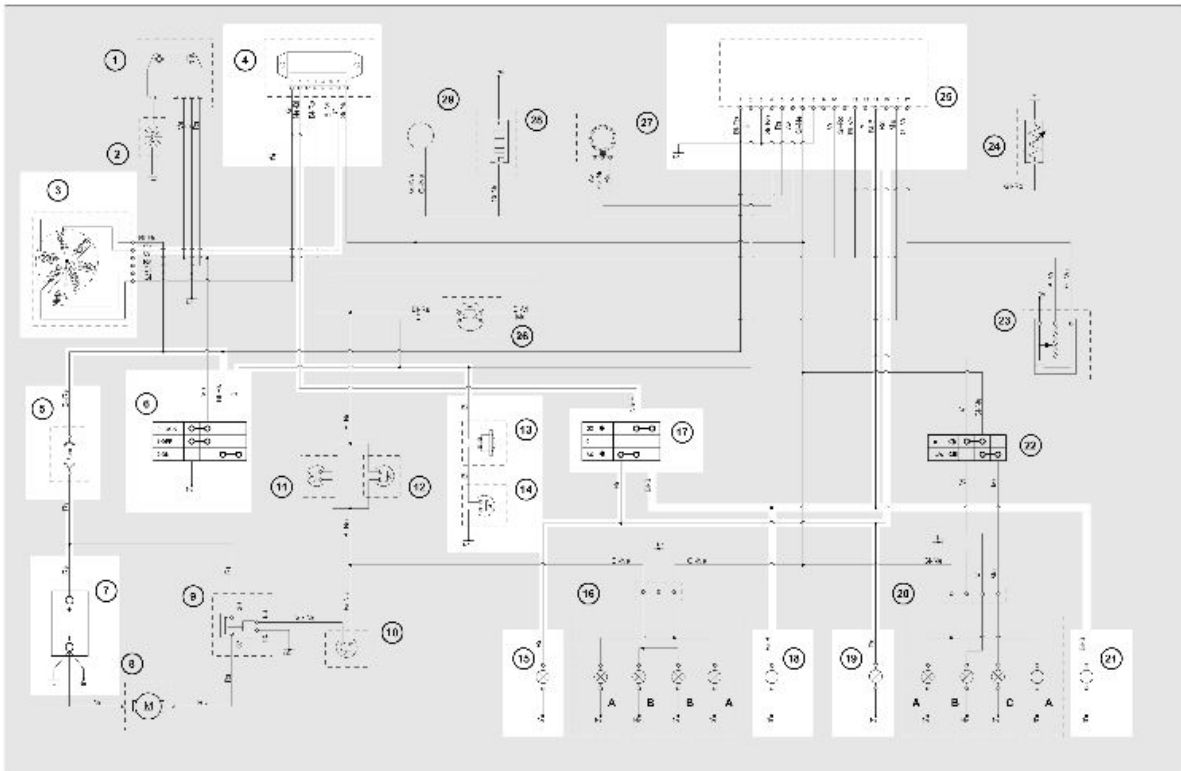

TURN INDICATORS AND HORN

- 3. Flywheel magneto
- 4 Voltage regulator
- 5. Main fuse 7.5 A
- 6 Key switch
- 7. Battery
- 13. Horn
- 14. Horn button
- 15. Left rear direction indicator light
- 17. Turn indicator switch
- 18. Right rear direction indicator light
- 19. Left front direction indicator light
- 21. Right front direction indicator light
- 25. Instruments unit

Digital instrument panel

instrument unit

- A= High-beam indicator light;
- B= Oil reserve mixer indicator light;
- C= Direction indicator light;
- D= Fuel reserve indicator light;
- E= Lights indicator light;
- F= Rev counter;
- G= "Mode" key;
- H= "Clock" key;
- L= "Set" key;
- M= Total/Trip odometer;
- N= Speedometer;
- O= Clock;
- P= Coolant temperature indicator (for liquid-cooled vehicles);
- S= Fuel level indicator;

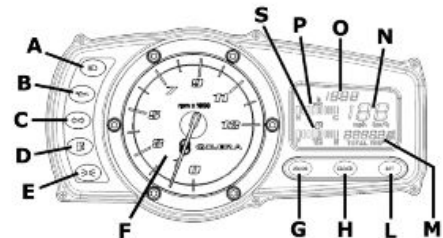

DIGITAL DISPLAY

- A= Fuel level gauge;
- B= Coolant temperature gauge;
- C= Digital clock;
- D= Speedometer;
- E= Odometer;
- F= Partial odometer gauge;
- G= Total odometer gauge;



INSTRUMENT UNIT CONNECTOR

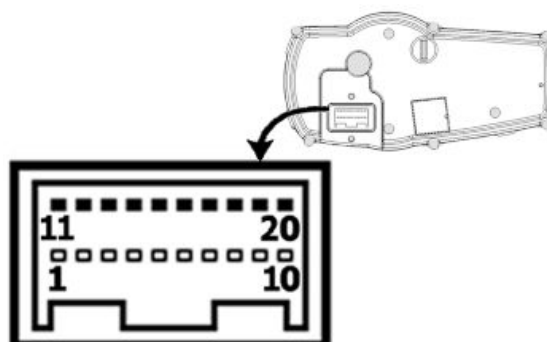

INSTRUMENT UNIT CONNECTOR

	Specification	Desc./Quantity
1	+ Battery	
2	+ permanent power supply	
3	Ground lead	

	Specification	Desc./Quantity
4	Grounding for phonic wheel	
5	Power supply to phonic wheel	
6	Phonic wheel signal	
7	Instrument light and parking light indicator	
8	Instrument temperature mass	
9	Not connected	
10	Rpm indicator signal	
11	Instrument temperature signal	
12	Fuel level sensor	
13	High-beam warning light	
14	+ Right direction indicator	
15	+ Left direction indicator	
16	Low-oil warning light	
17	Low fuel warning light	
18	Not connected	
19	Not connected	
20	Not connected	

Checks and inspections

Checks to be made in the case of ignition irregularities and/or no spark on the spark plug

1. Check the condition of the spark plug (clean it with a metal brush, remove the encrustations, blast it with compressed air and, if necessary, replace it).
2. Without removing the stator, carry out the following checks:

After visually checking the electrical wiring, perform measurements on the loading reel, the pickup (see chart) and the continuity using the appropriate tester.

If checks on the loading reel, pickup and continuity show abnormalities, replace the stator; otherwise replace the central unit. Remember that disconnections due to replacement of the central unit must be done with the engine off.

Specific tooling

020331Y Digital multimeter

CHECK ON THE PICK UP

	Specification	Desc./Quantity
1	Red and white cable	90±140 ohm

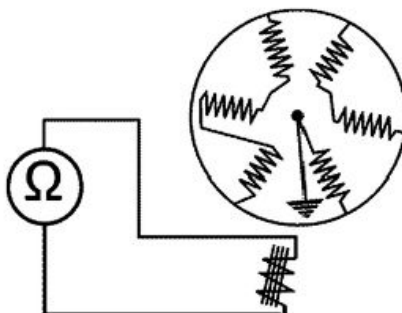

CHECK ON THE RELOAD REEL

	Specification	Desc./Quantity
1	Yellow and red-blue cable	800±1100 ohm

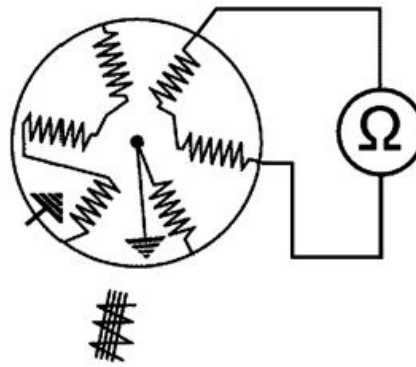

CHECK CONTINUITY

	Specification	Desc./Quantity
1	White cable-frame	continuity
2	White cable-engine	continuity

Ignition circuit

All the control operations of the system that require the disconnection of cables (checks of the connections and the devices making up the ignition circuit) must be done with the engine off: if this is not done, the controls might be irreparably damaged.

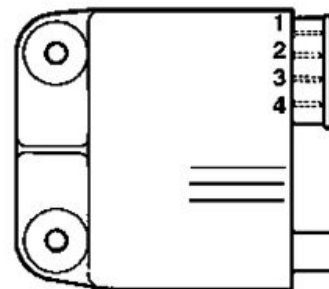

Stator check

- Using a tester, check the resistance between the red-ground and green-ground terminal.

N.B.

VALUES ARE STATED AT AMBIENT TEMPERATURE. A CHECK WITH THE STATOR AT OPERATING TEMPERATURE LEADS TO VALUES HIGHER THAN THOSE STATED.

Electric characteristic

Stator : green - ground

~ 1 Ω (Stator)

Pick-Up: red - ground

approx. 170 Ω (Pick-Up)

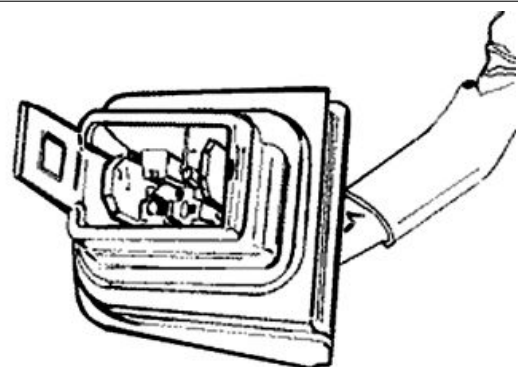

Voltage regulator check

The malfunctioning of the voltage regulator might cause the following problems depending on the type of fault:

1. The lighting system bulbs burn out.
2. The lighting system bulbs stop working.
3. The battery overcharges (the main fuse blows).
4. Non-recharging of the battery.
5. Non functioning of the turn indicators.

Interventions

BREAKDOWN 1

Replace the regulator due to inefficiency.

BREAKDOWN 2

Check the efficiency of the lamps.

With the vehicle in gear, check the presence of voltage to the battery on the yellow-black cable of the light deviator. If there is voltage present, check the correct voltage distribution of the stator: without disconnecting the connector of the regulator and with the vehicle in gear, use an alternating voltage tester to check that the voltage distributed at the connection between the grey cable and the black cable is included in the values indicated. If there are abnormalities, replace the stator.

If the checks made do not show abnormalities, replace the regulator.

If replacing the regulator still does not restore proper functioning, make the controls on the connections of the electrics.

Specific tooling

020331Y Digital multimeter

Characteristic

Voltage distributed at 3000 rpms

25 to 30V

FAULT 3

After checking that there are no short circuits in the system towards the earth, replace the regulator because it is certainly inefficient and replace it with a protective fuse.

Following the replacement, measure the current and the recharging voltage on the battery end.

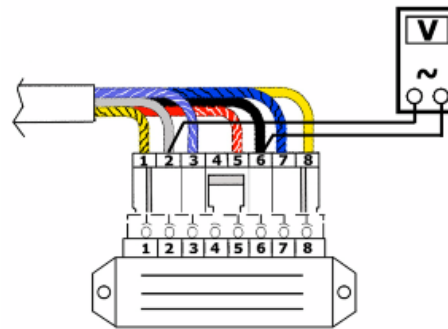

BREAKDOWN 4

Put the vehicle in gear and place the alternating voltage tester between the insertion of the blue-red cable and the yellow cable on the stator to check that the voltage distributed by the generator is between the values indicated. In the event of abnormalities, check the continuity of the stator, or continue with testing.

Insert the ammeter between the stator (blue-red cable) and the battery and using the tester to check that the current distributed at 3000 rpm is between 12V and 13V as indicated. If the values are lower than necessary, replace the regulator or the battery.

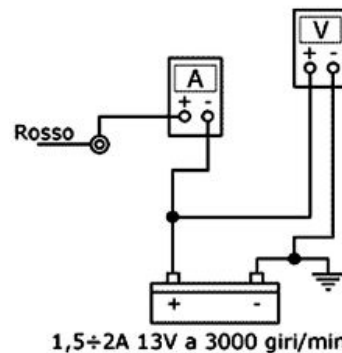
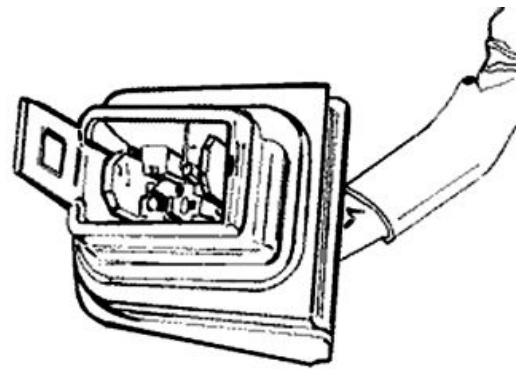

N.B.

BEFORE CARRYING OUT THE CHECKS ON THE REGULATOR AND RELATIVE SYSTEM, IT IS ALWAYS GOOD PRACTICE TO CHECK THAT THERE IS CONTINUITY BETWEEN THE BLACK CABLE AND THE GROUND.

N.B.

TO KEEP THE BATTERY BETWEEN 12 AND 13V, CAUSING CURRENT ABSORPTION BY THE SYSTEM, A 12V - 35W BULB CONNECTED BETWEEN THE + BATTERY AND GROUND CAN BE USED.

Specific tooling

020331Y Digital multimeter

Characteristic

Distributed current

1.5 to 2A

Voltage distributed at 3000 rpms

25 to 30V

FAULT 5

If the turn indicators do not work, do the following:

- Without removing the connector from the voltage regulator, move the key-controlled switch to ON and verify the presence of intermittent voltage between contact 7 and the ground. If there is voltage, the failure must be attributed to the flashing indicator switch

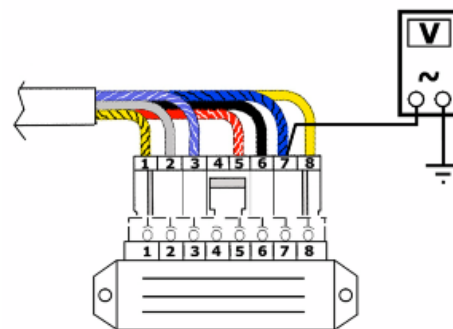

or the wiring, otherwise carry on with tests.

- With the engine off, remove the regulator connector, and insert the ends of the tester between contact 5 and the ground.
- Move the key controlled switch to ON and check there is battery voltage. If no voltage is detected, check the wiring and the contacts on the key switch and on the battery.

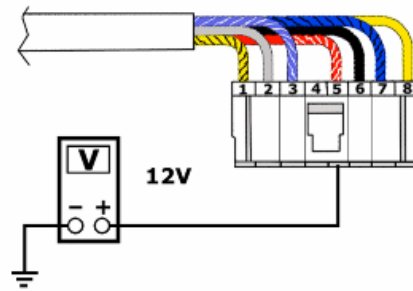

- Repeat the same procedure with the ends of the tester inserted between contact 5 (+) and 6 (-) and check the presence of the battery voltage with the key switch at on. If this does not happen, check the regulator's ground cable.

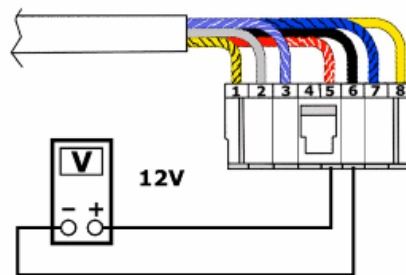

- If these last two tests have a positive result replace the regulator because it is certainly not functioning properly.

Specific tooling

020331Y Digital multimeter

Fuses

The electrics are protected by a fuse located on the right side next to the battery well. To replace it, remove the transparent protection mounted on the fuse holder. The ignition system, front headlight and rear taillight are not protected by fuses.

CAUTION

BEFORE REPLACING THE BLOWN FUSE, SEARCH AND ELIMINATE THE BREAKDOWN THAT HAS LED TO THE BLOW OUT. NEVER TRY TO REPLACE A FUSE USING DIFFERENT MATERIAL (FOR EXAMPLE A PIECE OF ELECTRIC WIRE) OR A FUSE FOR A HIGHER AMPERAGE THAN THE INDICATED ONE.

Electric characteristic

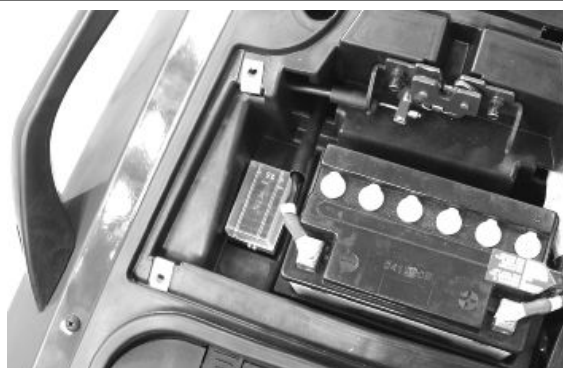

Fuse7.5 A

Sealed battery**Using the sealed battery for the first time**

INSTRUCTIONS FOR REFRESHING THE STOCK CHARGE OF AN OPEN CIRCUIT

1) Voltage check

Before installing the battery on the vehicle, check the open circuit voltage with a normal tester.

- If the voltage exceeds 12.60 V, the battery may be installed without any renewal recharge.
- If voltage is below 12.60 V, a renewal recharge is required as explained in 2).

2) Constant voltage battery charge mode

- Constant voltage equal to 14.40÷14.70V
- Initial charge voltage equal to 0.3÷0.5 for nominal capacity
- Duration of the charge: 10 to 12 h recommended

Minimum 6 h

Maximum 24 h

3) Constant current battery charge mode

- Charge current equal to 1/10 of the nominal capacity of the battery
- Duration of the charge: 5 h

WARNING

-WHEN THE BATTERY IS REALLY FLAT (WELL BELOW 12.6V) IT MIGHT BE THAT 5 HOURS OF RECHARGING ARE NOT ENOUGH TO ACHIEVE OPTIMAL PERFORMANCE. IN THESE CONDITIONS IT IS HOWEVER ESSENTIAL NOT TO EXCEED EIGHT HOURS OF CONTINUOUS RECHARGING SO AS NOT TO DAMAGE THE BATTERY ITSELF.

Dry-charge battery**WARNING**

THE BATTERY ELECTROLYTE IS POISONOUS AS IT MAY CAUSE SERIOUS BURNS. IT CONTAINS SULPHURIC ACID. AVOID CONTACT WITH THE EYES, THE SKIN AND CLOTHING. IF COMING INTO CONTACT WITH EYES OR SKIN, WASH ABUNDANTLY WITH WATER FOR APPROX. 15 MIN. AND SEEK IMMEDIATE MEDICAL ATTENTION.

IN THE EVENT OF ACCIDENTAL INGESTION OF THE LIQUID, IMMEDIATELY DRINK LARGE QUANTITIES OF WATER OR MILK, MAGNESIUM MILK, BATTERED EGG OR VEGETABLE OIL. SEEK IMMEDIATE MEDICAL ATTENTION.

THE BATTERIES PRODUCE EXPLOSIVE GAS; KEEP CLEAR OF NAKED FLAMES, SPARKS OR CIGARETTES; VENTILATE THE AREA WHEN RECHARGING INDOORS.

ALWAYS WEAR EYE PROTECTION WHEN WORKING IN THE PROXIMITY OF BATTERIES. KEEP OUT OF REACH OF CHILDREN

Use of dry-cell batteries :

1. Having removed the short, closed tube and removed the caps, put into the elements sulphuric acid of the type for specific weight 1.26 accumulators corresponding to 30° Bé at a temperature of no less than 15°, until you reach the upper level.
-

2. Leave to stand for at least 2 hours; afterwards top-up to the level with sulphuric acid.
3. Within twenty four hours, recharge with the special (single or multiple) battery charger that recharges at an intensity the same as approximately 1/10 the rated capacity of the said battery. At the end of the charge, make sure that the density of the acid is around 1.27, corresponding to 31° Bé and that these values are stabilised.
4. Once the charge is over, level the acid (by adding distilled water). Close and clean carefully.
5. Once the above operations have been performed, install the battery in the vehicle ensuring that it is wired up properly..

WARNING

- ONCE THE BATTERY HAS BEEN INSTALLED IN THE VEHICLE IT IS NECESSARY TO REPLACE THE SHORT TUBE (WITH CLOSED END) NEAR THE + POSITIVE TERMINAL WITH THE CORRESPONDING LONG TUBE (WITH OPEN END), THAT YOU FIND FITTED TO THE VEHICLE, TO ENSURE THAT THE GASES THAT FORM CAN ESCAPE PROPERLY.

Specific tooling

020333Y Single battery charger

020334Y Multiple battery charger

- 1 Hold the vertical tube
- 2 Look at the level
- 3 The float must be freed

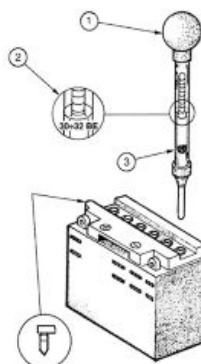
**Battery maintenance**

The battery is an electrical device which requires careful monitoring and diligent maintenance. The maintenance rules are:

1) Check the level of the electrolyte

The electrolyte level must be checked frequently and must reach the upper level. Only use distilled water, to restore this level. If it is necessary to add water too frequently, check the vehicle's electrical system: the battery works overcharged and is subject to quick wear.

2) Load status check

After restoring the electrolyte level, check its density using an appropriate densitometer (see the figure). When the battery is charged, you should detect a density of 30 to 32 Bé corresponding to a specific weight of 1.26 to 1.28 at a temperature of no lower than 15° C.

A density reading of less than 20° Bé indicates that the battery is completely flat and it must therefore be recharged.

If the scooter is not used for a given time (1 month or more) it will be necessary to periodically recharge the battery.

The battery runs down completely in the course of three months. If it is necessary to refit the battery in the vehicle, be careful not to reverse the connections, remembering that the ground wire (**black**) marked (-) must be connected to the **-negative** clamp while the other two **red** wires marked (+) must be connected to the clamp marked with the **+positive** sign.

3) Recharging the battery

Remove the battery from the vehicle removing the negative clamp first.

The normal bench charging must be carried out with the specific (single or multiple) battery charger, placing the battery charger selector on the type of battery to be recharged. The connections to the power supply must be made by connecting to the corresponding poles (+ with+ and -with -).

4) Battery cleaning

The battery should always be kept clean, especially on its top side, and the terminals should be coated with Vaseline.

WARNING

BEFORE RECHARGING THE BATTERY, REMOVE THE PLUGS OF EACH CELL. KEEP SPARKS AND NAKED FLAMES AWAY FROM THE BATTERY WHILE RECHARGING.

CAUTION

NEVER USE FUSES WITH A CAPACITY HIGHER THAN THE RECOMMENDED CAPACITY. USING A FUSE OF UNSUITABLE RATING MAY SERIOUSLY DAMAGE THE VEHICLE OR EVEN CAUSE A FIRE.

CAUTION

ORDINARY AND DRINKING WATER CONTAINS MINERAL SALTS THAT ARE HARMFUL FOR THE BATTERY. FOR THIS REASON, YOU MUST ONLY USE DISTILLED WATER.

CAUTION

CHARGE THE BATTERY BEFORE USE TO ENSURE OPTIMUM PERFORMANCE. INADEQUATE CHARGING OF THE BATTERY WITH A LOW LEVEL OF ELECTROLYTE BEFORE IT IS FIRST USED SHORTENS THE LIFE OF THE BATTERY.

Specific tooling

020334Y Multiple battery charger

020333Y Single battery charger

INDEX OF TOPICS

ENGINE FROM VEHICLE

ENG VE

Exhaust assy. Removal

- Rimuovere le due viti del coperchio scatola SAS
 - Rimuovere la marmitta agendo sui fissaggi del collettore di scarico e del carter motore.
- Per il montaggio eseguire le operazioni in ordine inverso.

Locking torques (N*m)

Muffler -cylinder nut 9 ÷ 11 Engine - muffler screw 22 ÷ 24

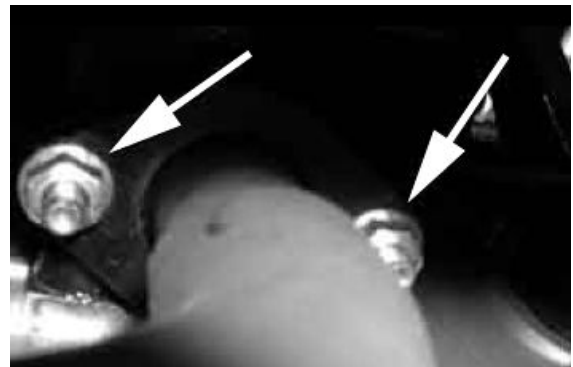
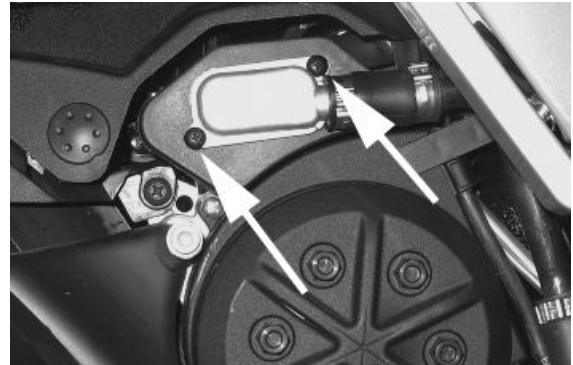

Removal of the engine from the vehicle

- Remove the rear mudguard by removing the three screws.
- Remove the rear brake calliper by removing the two screws, then remove the two supports of the brake tube and move the callipers toward the front of the vehicle to make subsequent removal operations easier.
- Remove the carburettor cover by removing the 4 screws.



- Remove the air filter by removing the two studs from the engine crankcase.
- Remove the air distribution intake cover by removing the four screws.
- Disconnect the transmission of the mixer command after removing the rubber plug on the transmission crankcase cover.





- Disconnect the electrical connection of the fly-wheel magneto.
- Disconnect the electrical connections of the starter.
- Disconnect the transmission of the accelerator command by using the screw.
- Disconnect the electrical connection of the thermostat and the H.V. coil of the spark plug.
- Remove the automatic starter, by removing on the two screws.

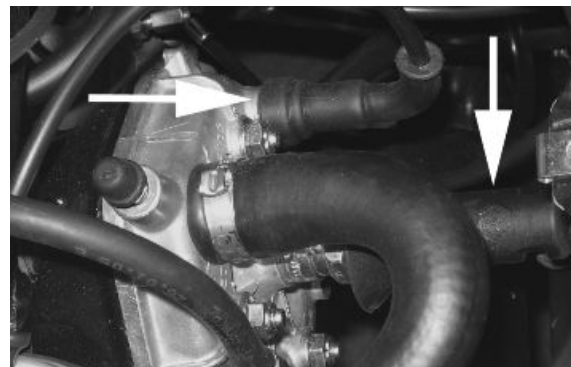



- Disconnect the mixer oil line from the oil tank.
- Remove the clamp to disconnect the fuel line and the fuel pump control line.
- Empty the cooling system and disconnect the supply and return lines using the respective clamps.

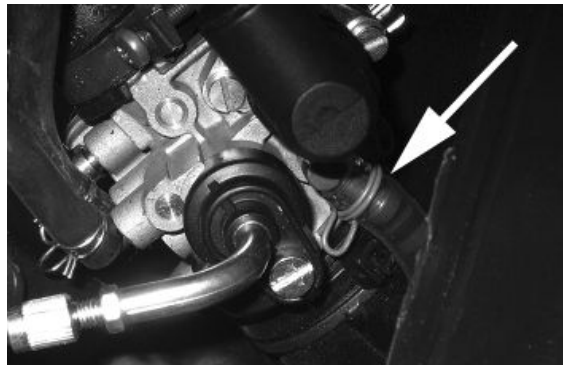
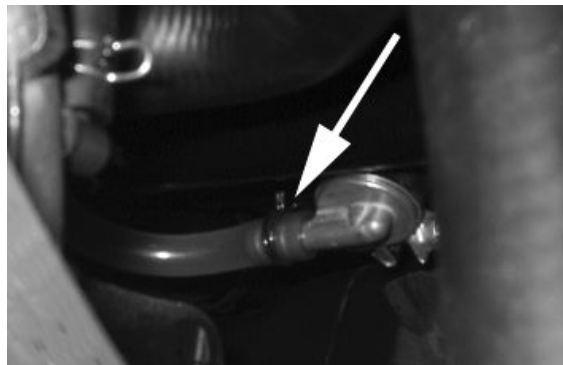

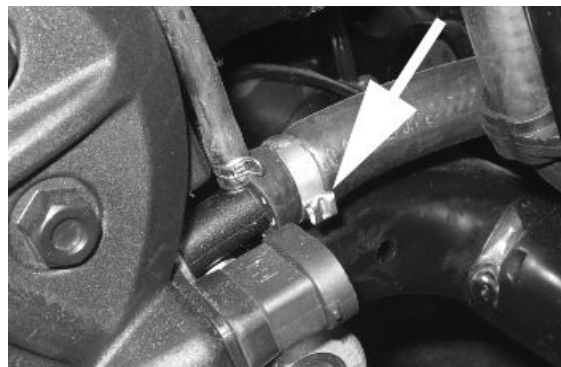

- Remove the bolt of the rear shock absorber of the engine crankshaft.
- Support the engine and remove the stud of the engine crankshaft at the swing arm.

Locking torques (N*m)

Swinging arm - engine pin* 33 ÷ 41 Shock-absorber - engine bolt * 33 ÷ 41

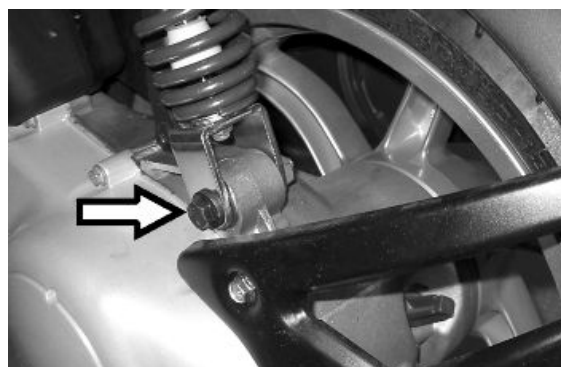

INDEX OF TOPICS

ENGINE

ENG

this section is under processing

Automatic transmission

Transmission cover

- Loosen the 15 screws and remove the transmission cover with the aid of a mallet.

N.B.

THE CRANKCASE IS SLIGHTLY BLOCKED BY THE TIGHT FIT BETWEEN THE SHAFT OF THE DRIVEN HALF-PULLEY AND THE BEARING HOUSED ON THE CRANKCASE.

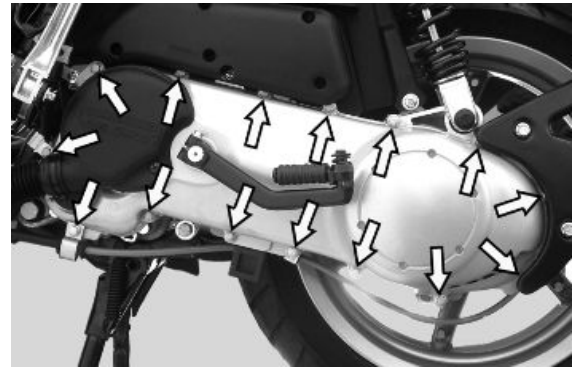

Kickstart

- Remove the seeger ring located on the exterior of the crankshaft.
- Dismantle the dog gear from its seat, slackening the tension that the toothed sector applies to it by means of the spring; to do this, it is necessary to rotate the toothed sector slightly (see the figure).

CAUTION

WHILE REMOVING THE TOOTHED SECTOR, BE VERY CAREFUL OF THE SPRING TENSION: IT COULD CONSTITUTE A HAZARD FOR THE OPERATOR.

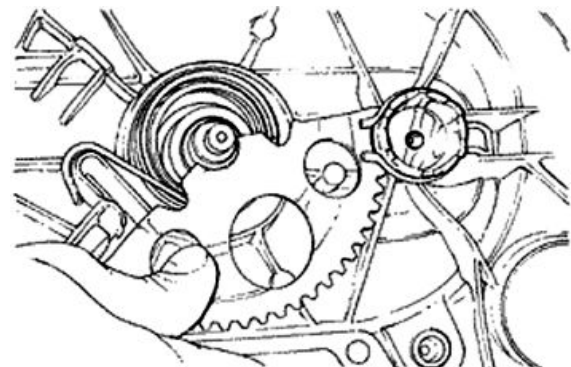

- Remove the screws shown in the figure and remove the engine starting lever.
- For the assembly, work in reverse and tighten the screws to the prescribed torque..

Locking torques (N*m)

Starter lever replacement 12 to 13 Nm

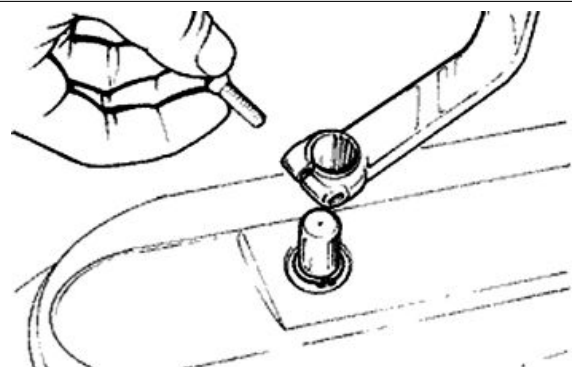

- Upon refitting, apply the recommended grease to the bushing, to the spring and along the toothed sector.
- Use the special tool for the charging of the spring, as shown in the figure.
- Refit the seeger ring after checking that it is in good condition.

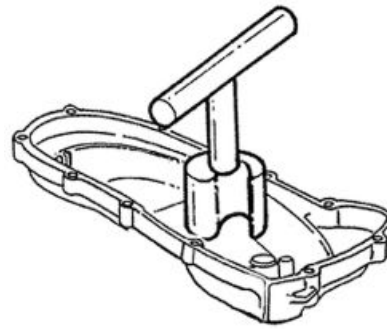

Specific tooling

020261Y Starter spring fitting

Recommended products

AGIP GREASE MU3 Grease for odometer transmission gear case

Soap-based lithium grease with NLGI 3; ISO-L-XBCHA3, DIN K3K-20

Removing the driven pulley shaft bearing

- Slightly heat the crankshaft from the inside side to avoid damaging the coated surface and use the driven pulley shaft or a pin of the same diameter to remove the bearing.

N.B.

IN CASE OF DIFFICULTY A STANDARD 8MM-INSIDE DIAMETER EXTRACTOR CAN BE USED.

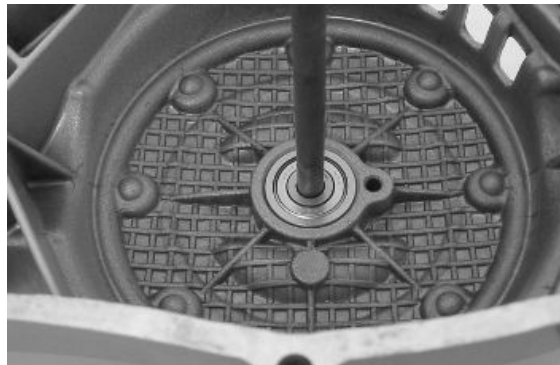

Refitting the driven pulley shaft bearing

- Refit the bearing with the aid of a bushing with the same diameter as the external plate of the bearing after slightly heating the crankcase from the inside.

N.B.

WHEN REFITTING, ALWAYS REPLACE THE BEARING WITH A NEW ONE.

CAUTION

WHEN REMOVING/REFITTING THE BEARING, TAKE CARE NOT TO DAMAGE THE PAINTED SURFACE.

Removing the driven pulley

- Lock the clutch bell housing with the specific tool.
- Remove the nut, the clutch bell housing and the whole of the driven pulley assembly.

N.B.

THE UNIT CAN ALSO BE REMOVED WITH THE DRIVE PULLEY MOUNTED.

Specific tooling

020565Y Flywheel lock calliper spanner



Inspecting the clutch drum

- Check that the clutch bell is not worn or damaged.
- Measure the inner diameter of the clutch bell.

Characteristic

Clutch bell diameter/standard value

Ø 107+0.2 +0 mm

Clutch bell diameter/max. value allowed after use

Ø 107.5 mm

Eccentricity measured /max.

0.20 mm



Removing the clutch

- Equip the tool with long pins screwed into position «A» from the outside, insert the entire driven pulley in the tool and put the central screw under stress.

CAUTION

THE TOOL WILL BE DEFORMED IF THE CENTRAL SCREW IS TIGHTENED UP TOO FAR.

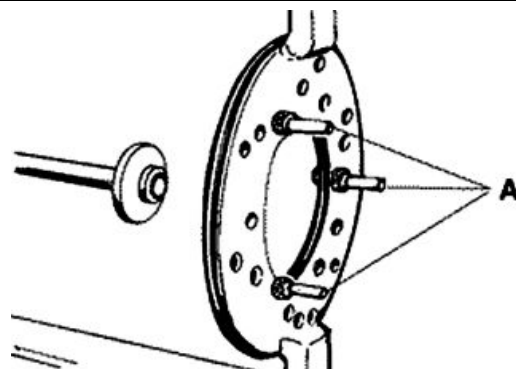

- Using a 34 mm socket wrench remove the clutch locking nut.
- Loosen the central screw thereby undoing the driven pulley unit
- Separate the components.

Specific tooling

020444Y Tool for fitting/ removing the driven pulley clutch

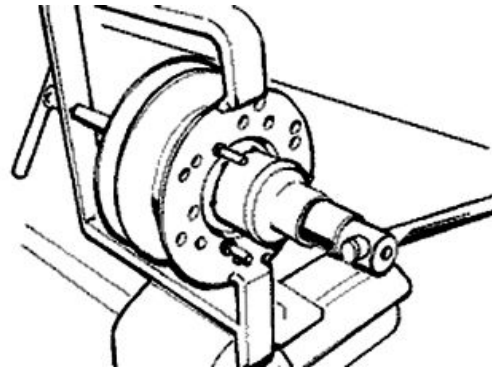

Inspecting the clutch

- Check the thickness of the clutch mass friction material.
- The masses must not show traces of lubricants; otherwise, check the driven pulley unit seals.

N.B.

UPON RUNNING-IN, THE MASSES MUST EXHIBIT A CENTRAL CONTACT SURFACE AND MUST NOT BE DIFFERENT FROM ONE ANOTHER.

VARIOUS CONDITIONS CAN CAUSE THE CLUTCH TO TEAR.

CAUTION

DO NOT OPEN THE MASSES USING TOOLS TO PREVENT A VARIATION IN THE RETURN SPRING LOAD.

Characteristic

Check minimum thickness

1 mm



Pin retaining collar

- Remove the collar with the aid of 2 screwdrivers.



- Remove the three guide pins and the mobile half pulley.



Removing the driven half-pulley bearing

- Remove the roller bearing with the special extractor inserted from the bottom of the fixed half-pulley.

CAUTION

POSITION THE HOLDING EDGE OF THE EXTRACTION PLIERS BETWEEN THE END OF THE BEARING AND THE BUILT IN SEALING RING.

Specific tooling

001467Y029 Bell for bearings, O.D. 38 mm



- Remove the ball bearing retention snap ring.
- Expel the ball bearing from the side of the clutch housing by means of the special tool.

N.B.

PROPERLY SUPPORT THE HALF-PULLEY SO AS NOT TO DEFORM THE SLIDING SURFACE OF THE DRIVING BELT

Specific tooling

020376Y Adaptor handle

020363Y 20 mm guide



Inspecting the driven fixed half-pulley

- Check that there are no signs of wear on the work surface of the belt. If there are, replace the half-pulley..
- Make sure the bearings do not show signs of unusual wear.
- Measure the external diameter of the pulley bushing.

Characteristic

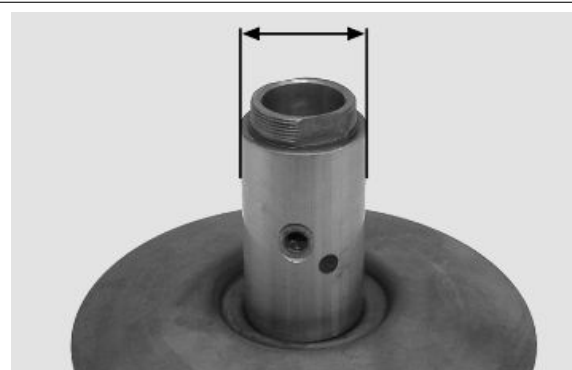

Stationary driven half-pulley/Standard diameter

Ø 33.965 to 33.985 mm

Stationary driven half-pulley / Minimum diameter admitted after use

Ø 33.96 mm

Inspecting the driven sliding half-pulley

- Remove the 2 inner sealing rings and the two O-rings.
- Measure the inside diameter of the mobile half-pulley bushing.

Characteristic**Mobile driven half-pulley/ Maximum diameter allowed**

Ø 34.08 mm

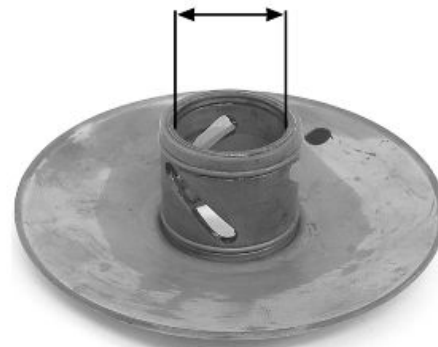

- Check the belt contact surfaces.
- Insert the new oil seal and O-rings on the mobile half-pulley.
- Fitting the half-pulley on the bushing.

Recommended products**AGIP GREASE SM 2 Grease for the tone wheel revolving ring**

Soap-based lithium grease containing NLGI 2 Molybdenum disulphide; ISO-L-XBCHB2, DIN KF2K-20



- Make sure the pins and collar are not worn, reassemble the pins and collar.
- Use a greaser with a curved spout to lubricate the driven pulley unit with around 6 gr. of grease. This operation must be done through one of the holes inside the bushing until grease comes out of the opposite hole. This procedure is necessary to prevent the presence of grease beyond the O-ring.

Recommended products**AGIP GREASE SM 2 Grease for the tone wheel revolving ring**

Soap-based lithium grease containing NLGI 2 Molybdenum disulphide; ISO-L-XBCHB2, DIN KF2K-20

Refitting the driven half-pulley bearing

- Fit a new ball bearing with the specific tool.
- Fit the ball bearing retention snap ring.
- Fit the new roller bearing with the wording visible from the outside.

CAUTION

PROPERLY SUPPORT THE HALF-PULLEY TO PREVENT DAMAGE TO THE THREADED END WHILE THE BEARINGS ARE BEING FITTED.

Specific tooling

020376Y Adaptor handle

020456Y Ø 24 mm adaptor

020362Y 12 mm guide

020171Y Punch for Ø 17 mm roller case



Inspecting the clutch spring

- Check that the contrast spring of the driven pulley does not show signs of deformation
- Measure the free length of the spring

Characteristic

Standard length

118 mm

Minimum length allowed after use

XXXX

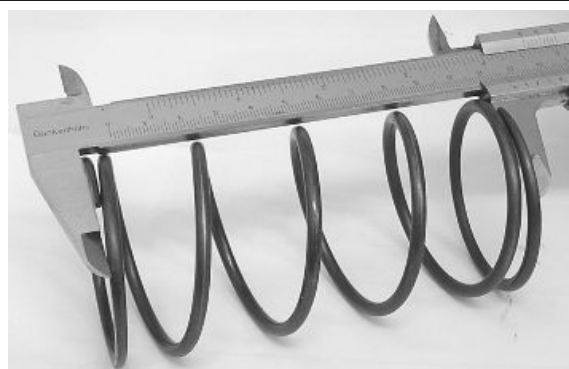

Refitting the clutch

- Preassemble the driven pulley group with spring, sheath and clutch.
- Position the spring with the sheath
- Insert the components in the tool and preload the spring being careful not to damage the plastic sheath and the end of the threaded bar.



- Reassemble the nut securing the clutch and tighten to the prescribed torque.

CAUTION

SO AS NOT TO DAMAGE THE CLUTCH NUT USE A SOCKET WRENCH WITH SMALL CHAMFER.

CAUTION

POSITION THE NON-CHAMFERED SURFACES OF THE NUT IN CONTACT WITH THE CLUTCH

Locking torques (N*m)

Nut locking clutch unit on pulley 55 ÷ 60 Nm

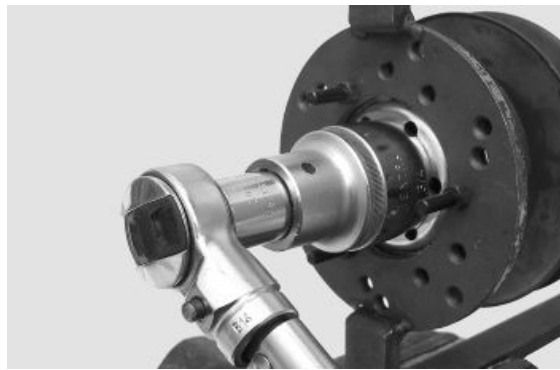

Refitting the driven pulley

-Refit the driven pulley assembly, the clutch bell and the nut, using the specific tool.

Specific tooling

020565Y Flywheel lock calliper spanner

Locking torques (N*m)

Driven pulley shaft nut 40 to 44 Nm

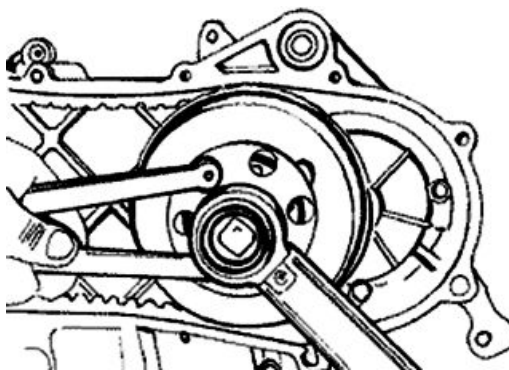

Drive-belt

- Make sure the driving belt is not damaged and does not have cracks in the toothed grooves.

- Check the width of the belt.

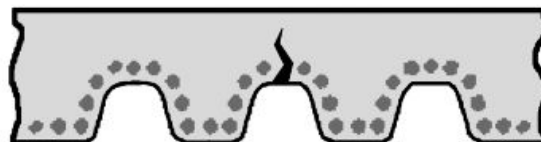

Characteristic

Transmission belt/Minimum width

17.5 mm



Removing the driving pulley

- Lock the driving pulley using the appropriate tool.
- Remove the central nut with the related washer, then remove the drive and the plastic fan.
- Remove the stationary half-pulley.

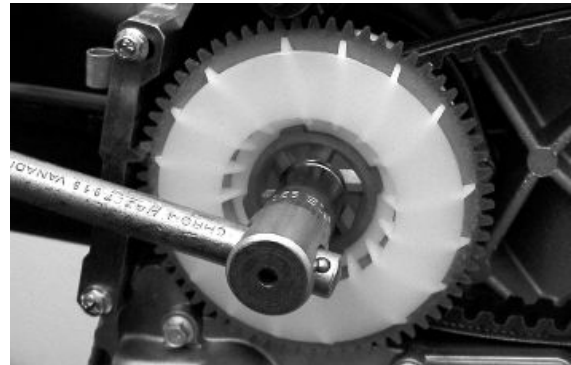

- Remove the belt, washer and remove the mobile half-pulley with its bushing, being careful that the rollers and contrast plate fitted loosely on it do not come off.

Specific tooling

020451Y Starting ring gear lock

Mixer gears and belt

- Remove gear and belt.

CAUTION

PAY PARTICULAR ATTENTION TO NOT TOUCHING OR BENDING THE BELT BECAUSE THIS COULD BREAK SUD- DENLY DURING OPERATION.

CAUTION

ON REFITTING, MAKE SURE THAT DIRT DOES NOT GET INTO THE INNER BUSHING OF THE MIXER CONTROL GEAR AND THAT IT DOES NOT EXERT ANY STRESS ON THE CRANKCASE PIN.

N.B.

REPLACE THE BELT EVERY 20000 KM.

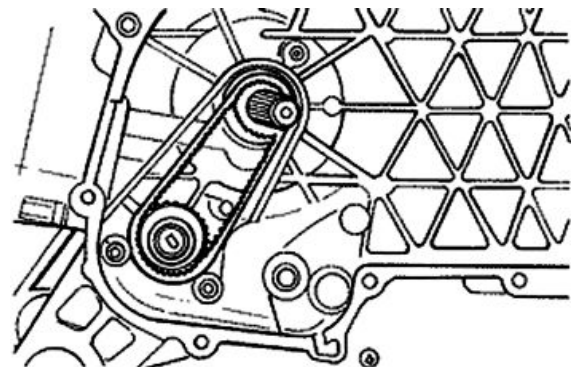

Inspecting the rollers case

- 1) Check that the bushing and the sliding rings of the mobile pulley do not show signs of scoring or deformation.
- 2) Check the roller running tracks on the contact pulley; there must not be signs of wear and check the condition of the contact surface of the belt on the half-pulleys (mobile and stationary).
- 3) Check that the rollers do not show signs of marked facetting on the sliding surface and that the metallic insert does not come out of the plastic shell borders.

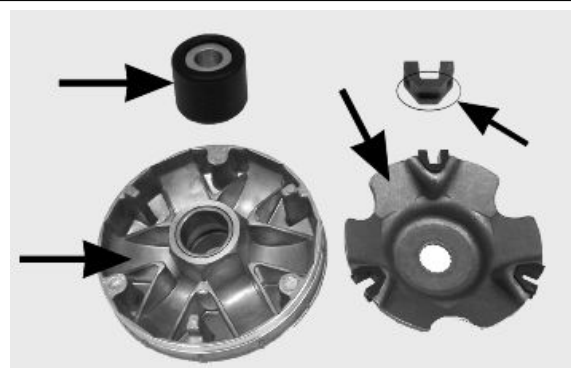

4) Check the integrity of the sliding blocks of the contact plate.

- Check that the internal bushing shown in the figure is not abnormally worn and measure inside diameter «A».

- Measure outside diameter «B» of the pulley sliding bushing shown in the figure.

CAUTION

DO NOT LUBRICATE OR CLEAN THE BUSHING.

Characteristic

Driving pulley / Maximum diameter:

20.12 mm

Driving pulley/ Standard diameter:

20.021 mm

Driving pulley bushing/ Diameter maximum:

XXX mm

Driving pulley bushing/ Standard diameter:

20 -0.020/-0.041mm

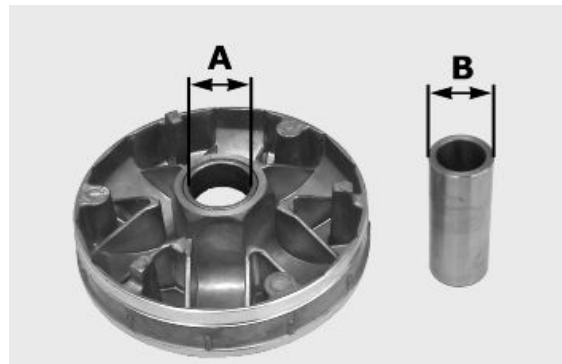

Refitting the driving pulley

- Manually move the movable driven half-pulley away by pulling it towards the clutch unit and insert the belt observing the direction of rotation of the first fitting.

N.B.

IT IS GOOD PRACTICE ALWAYS TO FIT THE BELT SO THAT THE WORDS CAN BE READ IN CASE IT DOES NOT SHOW A FITTING SIDE.



- Reassemble the unit parts (roller housing unit with bushing, washer, stationary half pulley, belt cooling fan with intake, washer and nut).

N.B.

REPLACE THE NUT WITH A NEW ONE AT EVERY REFIT

CAUTION

UPON FITTING THE DRIVING PULLEY UNIT IT IS OF UTMOST IMPORTANCE THAT THE BELT IS FREE INSIDE IN ORDER TO AVOID WRONG TIGHTENING AND CONSEQUENTLY DAMAGING THE CRANKSHAFT KNURLING.



Specific tooling

020451Y Starting ring gear lock

Locking torques (N*m)

Driving pulley nut 40÷ 44*

End gear

Removing the hub cover

- Remove the transmission cover
- Remove the clutch assembly
- Discharge the rear hub oil.
- Remove the 5 screws indicated in the figure.
- Remove the hub cover with driven pulley shaft.

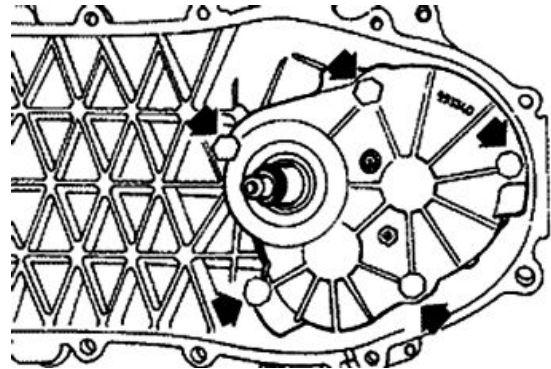

See also

[Refitting the clutch](#)

Removing the wheel axle

- Remove the intermediate gear and the complete gear wheel axle.
- When removing the intermediate gear pay attention to the various shim adjustments.

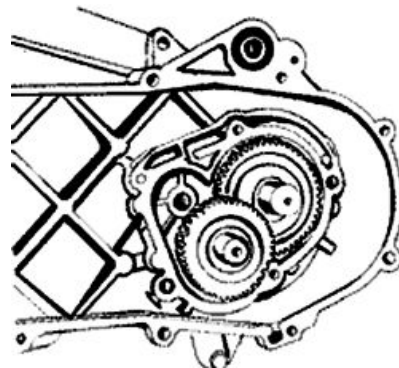

Removing the wheel axle bearings

- Remove the oil seal and the seeger ring.
- Remove the bearing by pushing from the outside towards the inside of the gear compartment, using the appropriate punch.

Specific tooling

020363Y 20 mm guide

020376Y Adaptor handle

020358Y 37x40-mm adaptor

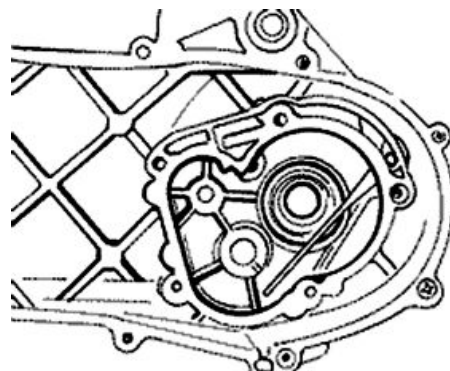

Removing the driven pulley shaft bearing

- Remove the seeger ring inside the cover.
- Remove the oil seal from the outside.
- Remove the centring dowels and position the cover on a plane.
- Position the special tool on the internal track of the bearing and remove said bearing with the aid of a press.

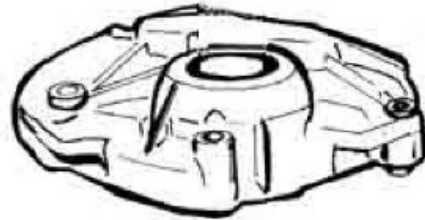

Specific tooling

020452Y Tube for removing and refitting the driven pulley shaft

- Position the special tube on the internal raceway of the bearing and from the shaft toothed side as indicated in the figure. Expel the driven pulley shaft with the aid of a press.

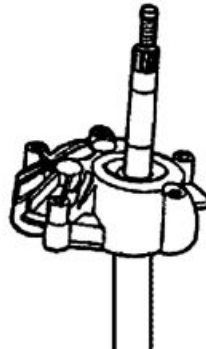

Specific tooling

020452Y Tube for removing and refitting the driven pulley shaft

Inspecting the hub shaft

- Check that the three shafts exhibit no wear or deformation on the toothed surfaces, at the bearing housings and at the oil guards.
- In case of anomalies, replace the damaged components.
- Check that the fitting surface is not dented or distorted.
- If faults are found, replace the hub cover.

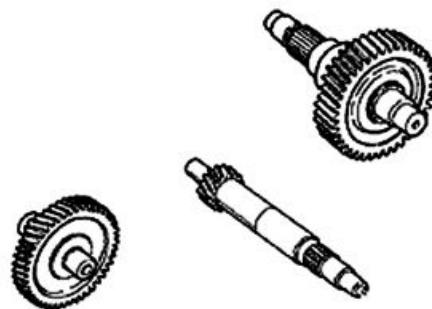

Inspecting the hub cover

- Check that the fitting surface is not dented or distorted.
 - If faults are found, replace the hub cover.
-

Refitting the driven pulley shaft bearing

- Support the inner track of the bearing from the outside of the hub cover with the specific tool positioned under the press and insert the driven pulley axle.
- Refit the oil seal flush with the cover.

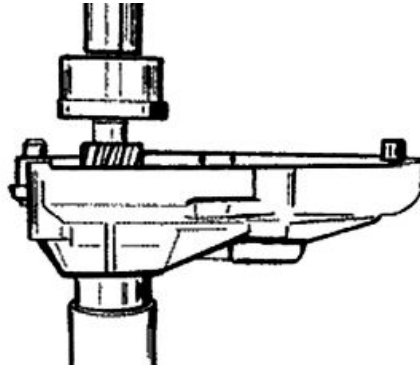

Specific tooling

020452Y Tube for removing and refitting the driven pulley shaft

- Heat the hub cover and insert the bearing with the specific punch.
- Fit the snap ring with the concave or radial part on the bearing side.

N.B.

FIT THE BALL BEARING WITH THE SHIELD FACING THE OIL SEAL.

Specific tooling

020151Y Air heater

020376Y Adaptor handle

020439Y 17 mm guide

020358Y 37x40-mm adaptor

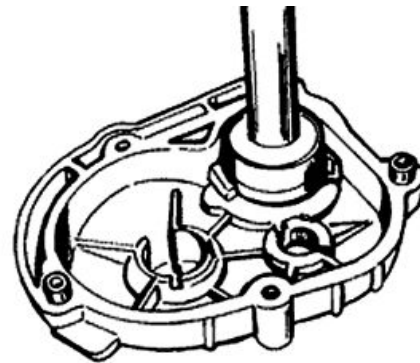

Refitting the wheel axle bearing

- Heat the half crankcase on the transmission side using a thermal gun.
- After lubricating its outer strip, insert the bearing with the special adapter with the aid of a hammer.
- Refit the seeger ring and the oil seal using the 42 x 47 mm adaptor and the handle.

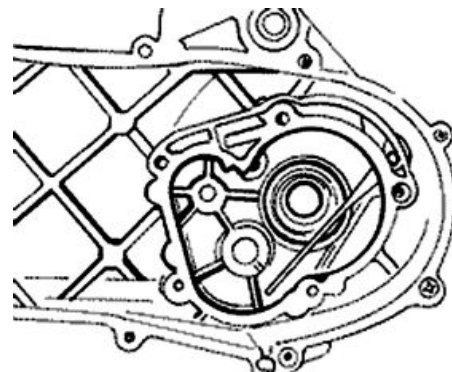

Specific tooling

020151Y Air heater

020376Y Adaptor handle

020363Y 20 mm guide

020359Y 42x47-mm adaptor

Refitting the ub cover

- Refit the whole wheel axle.
- Refit the intermediate gear paying attention to the two shim thicknesses.
- Apply LOCTITE 510 for surfaces to the hub covers and refit the same with driven pulley shaft.
- Refit the 5 screws and tighten them to the specified torque.

N.B.

CLEAN THE CONTACT SURFACES OF THE HUB COVER AND THE HALF CRANKCASE OF RESIDUE FROM PREVIOUS GASKETS BEFORE APPLYING A NEW ONE.

Locking torques (N*m)

Locking torque: 11 to 13 Nm

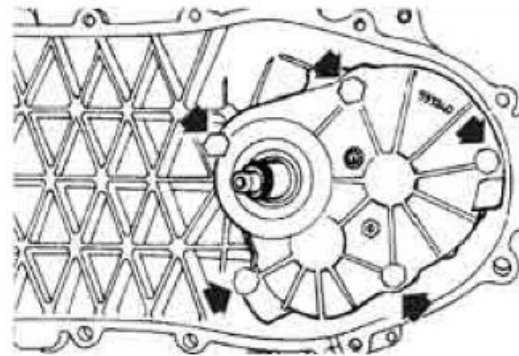
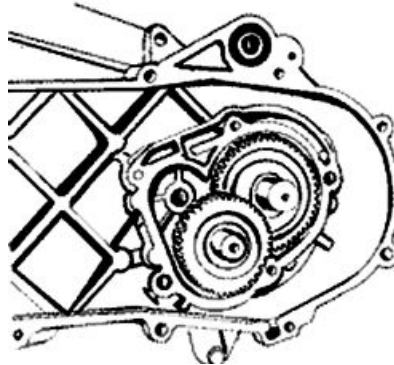

Flywheel cover

Removing the stator

- Remove the three stator fixings shown in the photo
- Remove the two pick-up fixings shown in the photo
- Remove the stator with the wiring

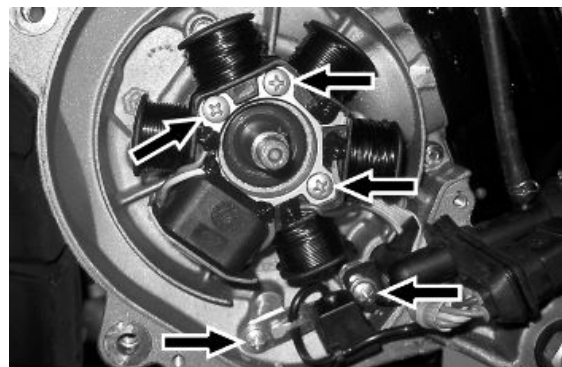

Refitting the stator

- Refit the stator and flywheel proceeding in the inverse direction, tightening the studs to the prescribed torque.

THREAD THE CABLE OF THE STATOR INTO THE SPECIFIC HOUSING OF THE CRANKCASE AND MAKE SURE THAT IT IS LOCKED BY THE TAB OF THE RETURN LINE OF THE COOLING SYSTEM.

Locking torques (N*m)

Pick-up screws 3 ÷ 4 Stator screws 3 ÷ 4



Refitting the flywheel cover

- Fit the rubber seal on the flywheel connector and around the inlet coolant hose.

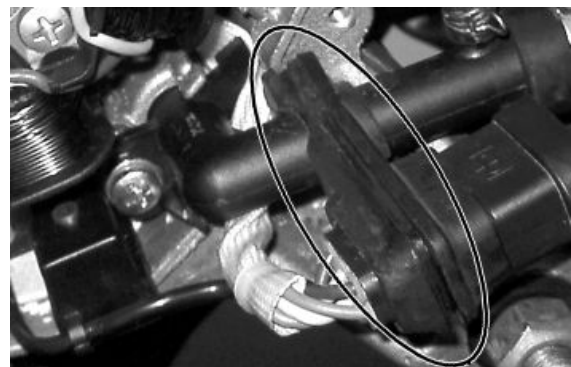

- Keeping the flywheel connector rubber clamp on the coolant inlet hose, refit the flywheel cover paying attention in inserting the strap in the groove.
- Tighten the 4 studs, noting that the two longer golden screws are inserted in the 2 top holes and are also responsible for restraining the secondary air-box.

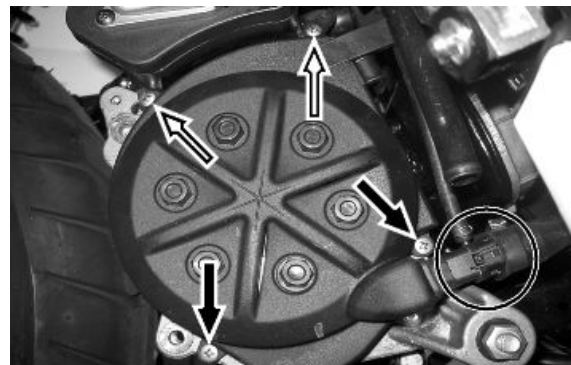

Flywheel and starting

Removing the starter motor

- Remove the center stand by unscrewing the four clamping screws (two per side) of the engine block
- R

Remove the two clamps shown in the figure

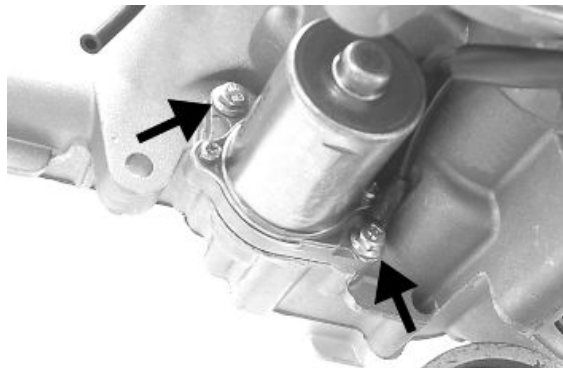

Removing the flywheel magneto

- Lock the rotation of the flywheel using the calliper spanner.
- Remove the nut.

CAUTION

THE USE OF A CALLIPER SPANNER OTHER THAN THE ONE SUPPLIED COULD DAMAGE THE STATOR COILS



- Extract the flywheel with the extractor.

Specific tooling

020565Y Flywheel lock calliper spanner

020162Y Flywheel extractor



Inspecting the flywheel components

- Check the condition of the flywheel and any distortions that might cause rubbing on the stator and on the Pick-Up.



Refitting the flywheel magneto

- Fit the flywheel being careful to insert the key properly.
- Lock the flywheel nut at the prescribed torque
- Check the Pick-Up air gap.
- The air gap may not be modified in the fitting of the Pick-Up.
- Other values derive from deformations visible on the Pick-Up support.



N.B.

A VARIATION OF THE AIR GAP DISTANCE CAN LEAD TO A VARIATION IN THE IGNITION ADVANCE SUCH AS TO CAUSE PINGING, KNOCKING ETC.

Locking torques (N*m)

Flywheel nut 40 to 44 N.m

Refitting the starter motor

- Fit a new O-ring on the starter and lubricate it.
- Fit the starter on the crankcase, locking the two screws to the prescribed torque.

N.B.

REFIT THE REMAINING PARTS AS DESCRIBED IN THE CYLINDER HEAD, TIMING, LUBRICATION, FLYWHEEL AND TRANSMISSION CHAPTERS.

Locking torques (N*m)

Starter motor screws 11 ÷ 13

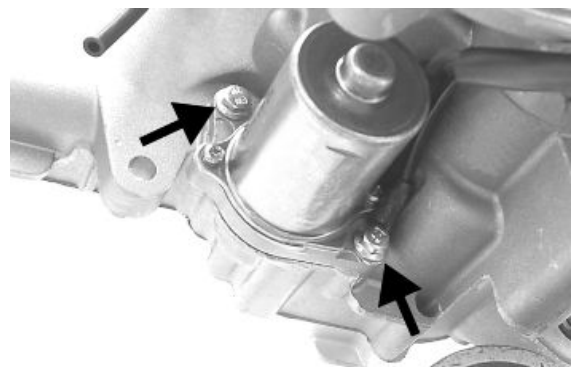

Cylinder assy. and timing system

Removing the intake manifold

Use an anti-tampering TORX spanner to remove the two clamping screws of the intake manifold

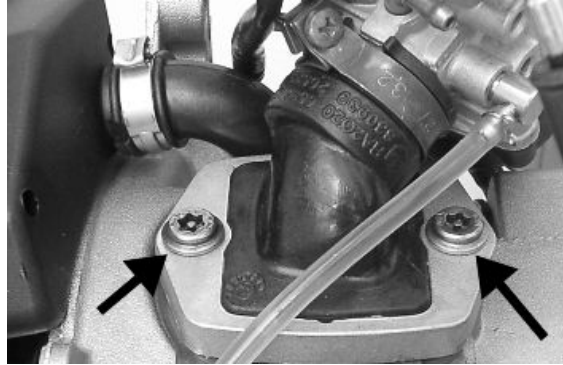

Removing the cylinder head

Remove the 4 screws shown in the figure

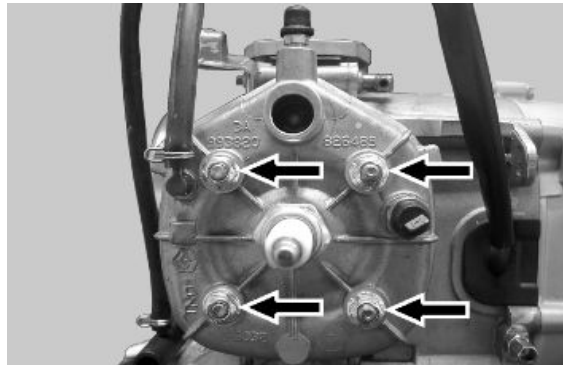

Removing the cylinder - piston assy.

- Remove the cylinder holding the piston in order to prevent damage



- Remove the 2 plug stops by a screwdriver inserted into the special slits on the piston
- Remove piston pin and remove the piston

N.B.

USE PAPER OR A CLOTH TO CLOSE THE CYLINDER HOUSING MOUTH ON THE CRANKCASE TO PREVENT SLIPPAGE OF ONE OF THE PIN LOCKING RINGS INTO THE CASE.



- Remove the roller from the connecting rod as shown in the figure

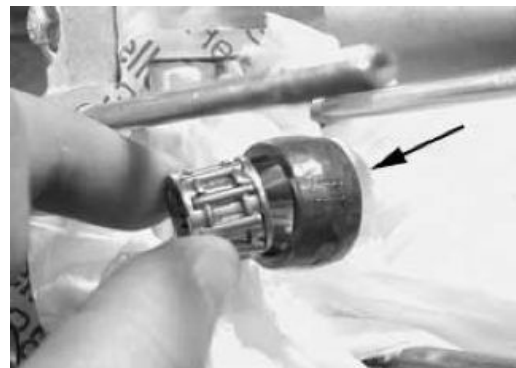

- Remove the piston sealing rings

CAUTION

NOTE THE ASSEMBLY POSITIONS OF THE LININGS TO PREVENT INVERTING THE POSITION IN CASE OF REUSE.

N.B.

BE CAREFUL NOT TO DAMAGE THE SEALING RINGS DURING REMOVAL.



Inspecting the small end

- Measure the internal diameter of the small end using an internal micrometer.

N.B.

IF THE DIAMETER OF THE ROD SMALL END EXCEEDS THE MAXIMUM DIAMETER ALLOWED, SHOWS SIGNS OF WEAR OR OVERHEATING REPLACE THE CRANKSHAFT AS DESCRIBED IN THE "CRANKCASE AND CRANKSHAFT" CHAPTER".

Characteristic

Rod small end: standard diameter

17 +0.011-0.001

Rod small end: maximum allowable diameter

17,060 mm



Inspecting the wrist pin

- Check the wrist pin external diameter using a micrometer

Characteristic

Wrist pin: standard diameter

12 +0.005 +0.001 mm



Inspecting the piston

- Measure the bearings on the piston using a bore meter
- Calculate the piston-pin coupling clearance.

Characteristic

Wrist pin housing: standard diameter

12 +0.007 +0.012

Wrist pin housing: standard clearance

0.002 ÷ 0.011 mm



- Measure the outer diameter of the piston, perpendicular to the pin axis.
 - Take the measurement in the position shown in the figure
- To classify the cylinder-piston fitting, check the appropriate table

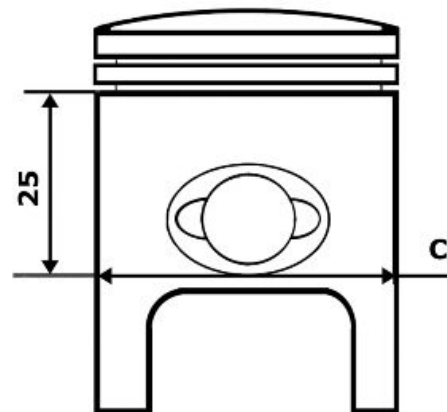

See also

[Cylinder - piston assy.](#)

Inspecting the cylinder

- Check that the cylinder does not show seizures. Otherwise, replace it or adjust it respecting the allowable increases
- Measure the internal diameter of the cylinder with a bore meter, according to the directions given in the figure
- Check that the fitting surface with the head is not dented or distorted.

To classify the cylinder-piston fitting, check the appropriate table

See also

[Cylinder - piston assy.](#)

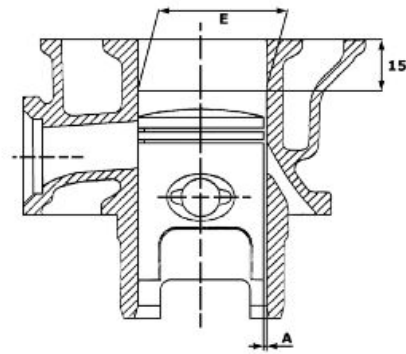

Inspecting the piston rings

- Alternatively insert the two sealing rings in the cylinder
- Using the piston, insert the seals perpendicularly to the cylinder axis.
- Measure the opening of the sealing rings using a thickness gauge as shown in the photograph
 - If the values are higher than the values prescribed in the chart, substitute the rings

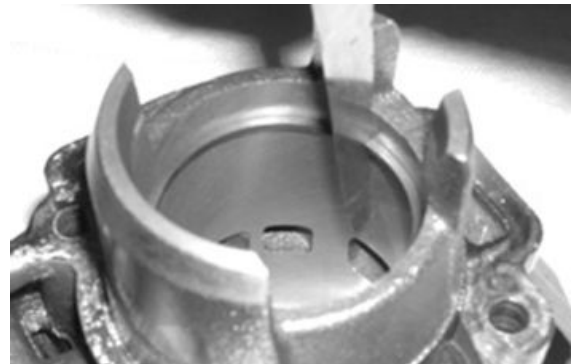

Removing the piston

- Insert the roller in the connecting rod



- Fit piston and wrist pin on the connecting rod, with piston facing the outlet

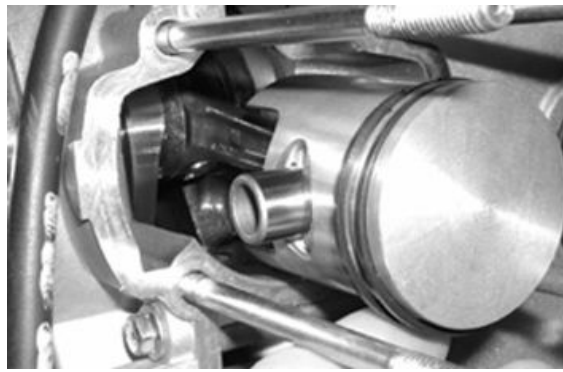

- Insert the wrist pin stop ring in the specific tool with the aperture in the position shown on the tool, as in the figure



- Place the wrist pin stop ring into position using a punch

Specific tooling

020166Y Pin lock fitting tool



- Fit the wrist pin stop using the plug as shown in the figure

Specific tooling

020166Y Pin lock fitting tool



Choosing the gasket

- Temporarily fit the cylinder on the piston, without the basic gasket.
- Fit a dial gauge on the specific tool, using the short union as shown in the figure.



Use a reference plane to reset the dial gauge with a pre-load of a few millimetres.

Set the dial gauge.

Check that tracer slides smoothly.

Fit the tool on the cylinder without changing the dial gauge position.

Lock the tool by the nuts used to secure the head.



Turn the engine shaft to the dead centre position (dial gauge rotation inversion point).

Measure the difference with the reset value.

Refer to the table to identify the thickness of the cylinder base gasket to use for refitting. The correct identification of the thickness of the cylinder base gasket allows maintaining the correct compression ratio.

Remove the specific tool and the cylinder.

Specific tooling

020272Y Piston position check tool

See also

[Cylinder - piston assy.](#)

Inspecting the timing system components

CAUTION

CHECK THE CORRECT REED UNIT SEAL; NO LIGHT MUST PASS BETWEEN THE SUPPORT AND LAMELLA.

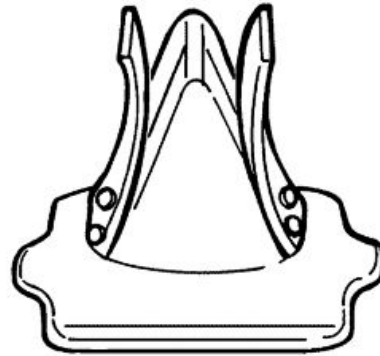

Crankcase - crankshaft

Splitting the crankcase halves

Remove the eight crankcase union fasteners.

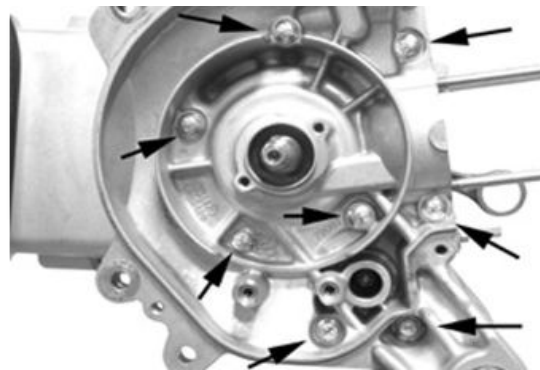

Install the special strip on the half crankcase on the flywheel side and separate the half crankcase on the flywheel side from the transmission side

Specific tooling

020163Y Crankcase splitting plate

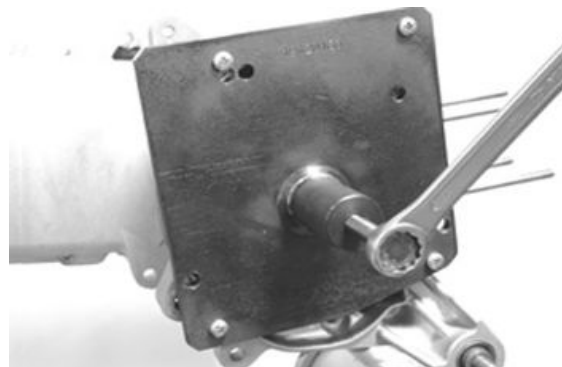

Removing the crankshaft

- Install the specific tool on the half crankcase on the transmission side using four M6 screws of an adequate length.
- Remove the crankshaft from the transmission side half crankcase

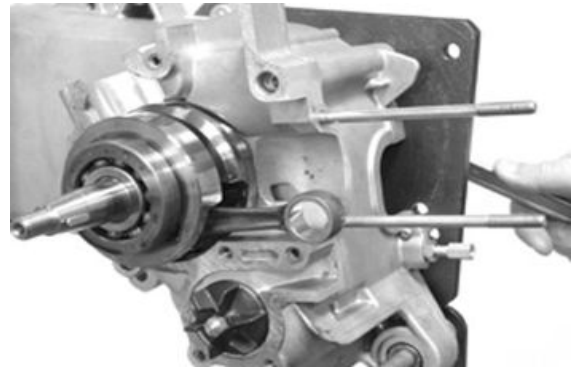

Specific tooling

020163Y Crankcase splitting plate

Removing the crankshaft bearings

- The bearings can stay on either the half crankcase or the crankshaft indifferently
- Using the special tool, remove any bearings that have been left on the crankshaft



N.B.

The half rings must be inserted on the bearings with a few mallet blows.

Specific tooling

004499Y001 Bearing extractor bell

004499Y006 Bearing extractor ring

004499Y002 Bearing extractor screw

004499Y007 Half rings

- Using the specific tool remove any bearings left on the half crankcase



Specific tooling

001467Y007 Driver for OD 54 mm bearing

001467Y006 Pliers to extract 20 mm bearings

Refitting the crankshaft bearings

- This operation requires assembly by temperature
- Dip the bearings in oil bath when this is still cold.
Avoid contact between bearings and container.
- Use an appropriate amount of oil (approx. 1 l)



- Gradually heat the container with a thermal gun until the oil temperature reaches approx. 150°.
- Check the temperature using a multimeter provided with thermal probe

N.B.

IF THE BEARINGS WERE IMMERSED INTO HOT OIL, THEY WOULD BE IMMEDIATELY DAMAGED.



- Place the crankshaft on the special support
- Alternately introduce the 2 bearings to insert them home.
- If required, use a specific pipe to ensure their insertion.

N.B.

THIS OPERATION SHOULD BE PERFORMED QUICKLY AND WITH PRECISE MOVES. OTHERWISE, START OVER.

Specific tooling

020265Y Bearing fitting base

008119Y009 Tube to assemble shafts and axles



Inspecting the crankshaft alignment

With the specific tool shown check that the eccentricity of the surfaces of diam. «A»-«B»-«C» are within 0.03 mm. (reading limit on the dial gauge); in addition, check the eccentricity of diam. «D», for which a maximum reading of 0.02 mm is permitted. In the case where eccentricity is not much above prescribed levels, **straighten** the shaft by acting on the counterweights with a shim or tighten them in a clamp (with an aluminium bushing) as required..

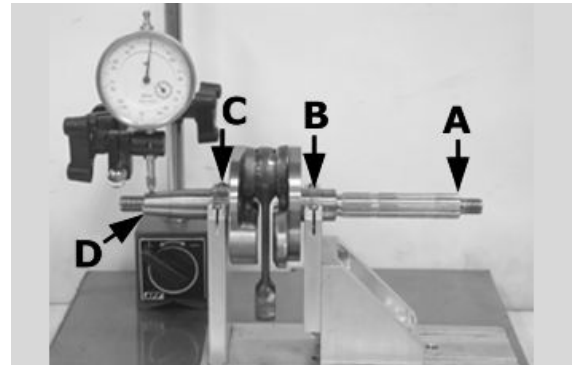

Specific tooling

020335Y Magnetic support for dial gauge

020074Y Support base for checking crankshaft alignment

Refitting the crankshaft

- Position the transmission side half crankcase on two wooden supports
- Using a thermal gun, heat the bearing seat about 120°



- Firmly insert the crankshaft until the bearing reaches the end-of-stroke stop



- Let the temperature of the half crankcase settle at the temperature of the crankshaft.
- Again install the special crankcase separation plate **NOT** installing the crankshaft protection
- During the assembly phase keep the central thrust screw loose.
- Take the four clamping screws to the end of the stroke and loosen them again with the same angle (e.g. 90°)
- When the temperature has settled, preload the thrust screw of the tool manually until the ball bearing clearance is cancelled out.

Specific tooling

020163Y Crankcase splitting plate

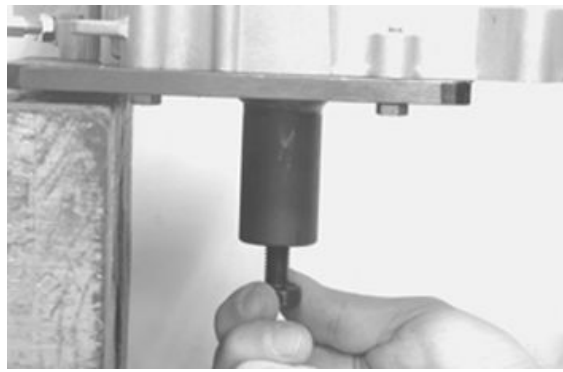

Refitting the crankcase halves

- Prepare the coupling surface with LOCTITE 510 applying a thin layer of it after degreasing the surface using a suitable solvent (e.g. trichloroethylene)
- Heat the flywheel-side half crankcase with a thermal gun.

Recommended products

Loctite 510 Liquid sealant

Gasket

- Keeping the half crankcase on the transmission side, insert the flywheel side half crankcase with a clean precise movement
- Insert at least three clamping screws and tighten up rapidly
- Insert the other 5 screws and tighten them to the specified torque.

Locking torques (N*m)

crankcase coupling screws 11 - 13

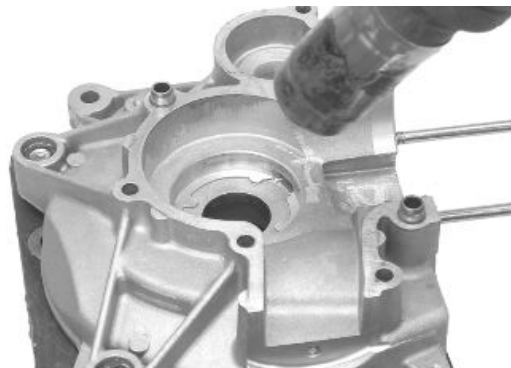

- Move the crankcase separation plate in a position back from the one indicated in the figure
- Install the special magnetic support with dial gauge at the end of the crankshaft
- Check the axial clearance of the crankcase
If this is not within the maximum limit allowed, repeat the crankcase coupling procedure

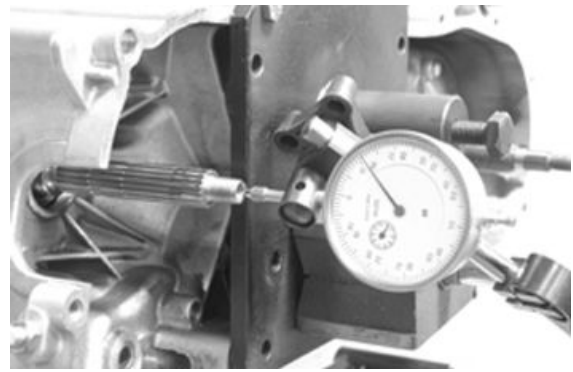

Specific tooling

020335Y Magnetic support for dial gauge

Characteristic

Axial clearance with warm crankcase

0.10 ÷ 0.12 mm

Axial clearance with cold crankcase

0.06 to 0.08 mm

Limit value with cold crankcase

0.02 ÷ 0.03 mm

Lubrication

Crankshaft oil seals

Refitting

- Install a new flywheel-side oil seal only with the special tool's punch
- The flywheel-side oil seal is recognised by its smaller diameter

N.B.

THE USE OF THE SPECIFIC TOOL IS NOT COMPATIBLE WITH THE FITTED WRENCH

Specific tooling

020340Y Flywheel and transmission oil seals fitting punch



- Install a new transmission side oil seal using the special tool with adapter ring.

The transmission-side oil seal is recognised by the larger diameter

Specific tooling

020340Y Flywheel and transmission oil seals fitting punch



Oil pump

Removal

- Remove the 2 screws shown in the figure

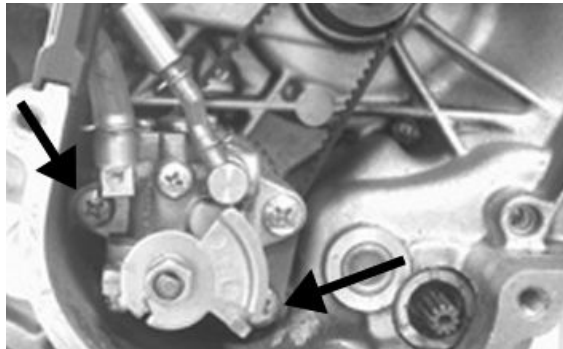

Remove the tube passage seal from the crankcase shown in the figure

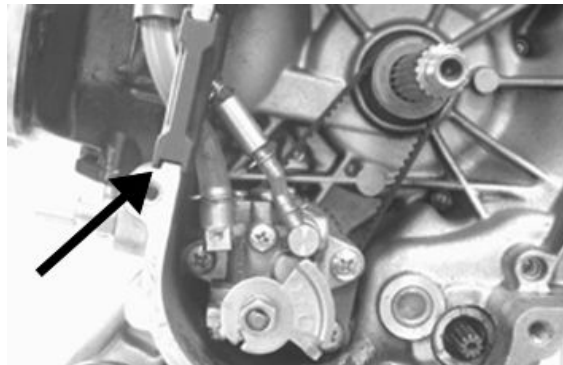

Refitting

To refit, perform the steps in the reverse direction to disassembly

Remember to drain after refitting using the screw shown in the figure

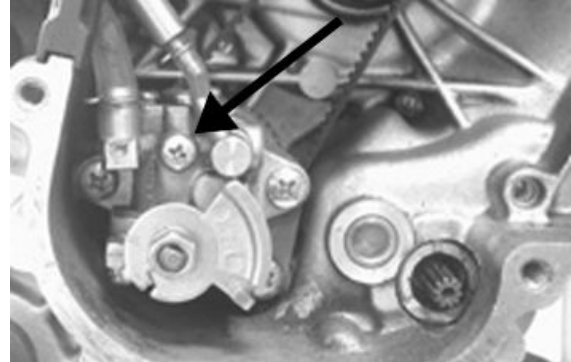

Fuel supply

The vehicle comes with a membrane pump controlled by the depression that is generated in the intake manifold. Therefore, the tank has an intake in the lowest point that sends the fuel to the pump and from here to the carburettor.

To determine the correct functioning of the pump, the following measurements can be made on the amounts distributed:

- 1) Start up the engine, bring it to normal operating temperature and then shut it off.
- 2) Disconnect the fuel adduction line on the carburettor and insert it into a graduated tube.
- 3) Start up the engine without the accelerator and keep it idle.
- 4) After the engine is started, count to 10 and then turn it off.
- 5) Check that the quantity of fuel is not less than the prescribed value.

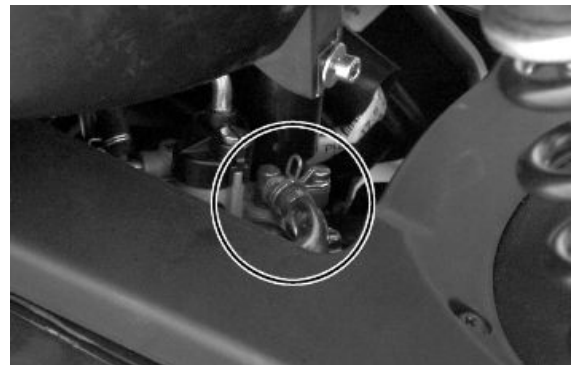

Characteristic

Fuel distributed

~100cc X 10"

INDEX OF TOPICS

SSUSPENSIONS

SUSP

Front suspension

This section is devoted to operations that can be carried out on the suspension.

Front

Removing the front wheel

- Remove the fixing nut from the wheel axle on the left side of the vehicle.
- Loosen the fixing screw of the wheel axle clamp and remove it.

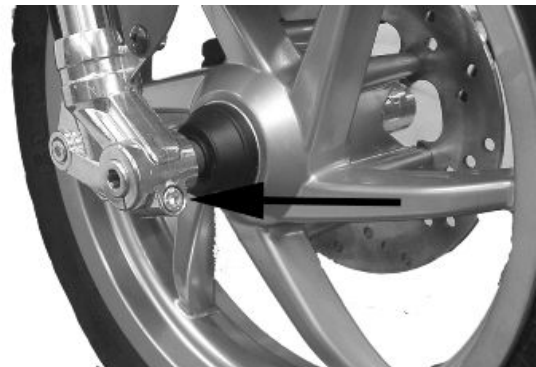
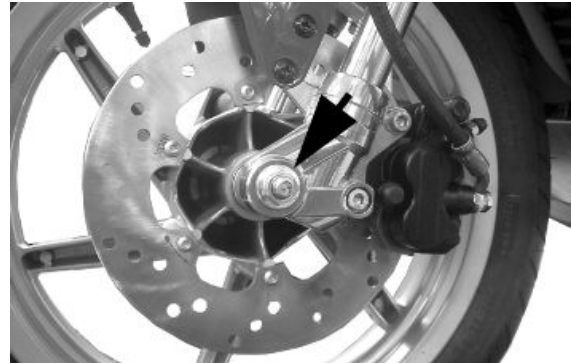

Front wheel hub overhaul

- Remove the front wheel
- Keep the wheel level by means of two wooden wedges
- With the appropriate pliers and tool remove the wheel bearing on the side the rpm indicator detects movement, as shown in the photograph

Specific tooling

001467Y014 Pliers to extract \varnothing 15-mm bearings

001467Y009 Driver for OD 42-mm bearings



- Remove the internal spacer
- Use appropriate handle, adaptor and guide and hit with a mallet to extract the bearing and the spacer bushing on the brake disk side; insert handle on the side the rpm indicator detects movement, as shown in the photo



Specific tooling

020376Y Adaptor handle

020456Y Ø 24 mm adaptor

020412Y 15 mm guide

- Check that the bearings do not show flaws or jamming. If there is, replace it.
- Check that the internal spacer does not show abnormal wear. If there is, replace it.
- With a hot air gun heat the seat of the bearing on the brake calliper side
- With an appropriate tool remove the bearing on the brake disk side
- Insert the spacer bushing on the brake disk side



Specific tooling

020376Y Adaptor handle

020357Y 32 x 35 mm adaptor

020412Y 15 mm guide

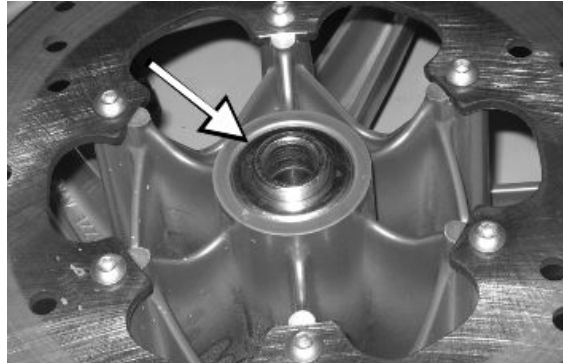

- With a hot air gun heat the seat of the bearing on the side the rpm indicator detects movement
- Insert the internal spacer with the centring ring facing to the brake disk side, as shown in the photo
- Use an appropriate tool to insert the bearing on the rpm indicator movement detector side



Specific tooling

020376Y Adaptor handle

020357Y 32 x 35 mm adaptor

020412Y 15 mm guide

See also

Removing the front wheel

Refitting the front wheel

- When refitting, pay attention in repositioning the odometer drive correctly.

Locking torques (N*m)

Wheel axle nut 45 ÷ 50 Wheel axle clamp screws 6 - 7 Nm

Handlebar

Removal

- Remove the front handlebar cover.
- Remove the rear handlebar cover.
- After removing the transmissions and disconnecting the electrical terminals, remove the bolt «A» and the handlebar
- Check all components and replace faulty parts.

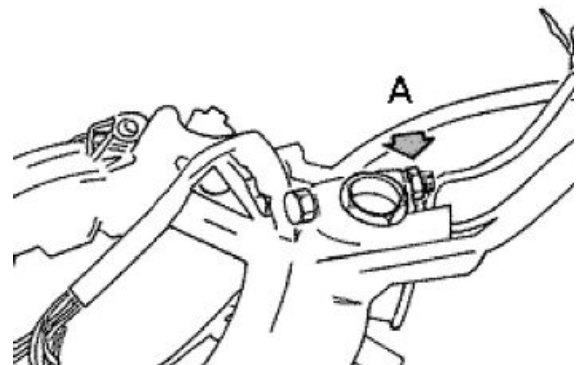

N.B.

IF THE HANDLEBAR IS BEING REMOVED TO REMOVE THE STEERING, TILT THE HANDLEBAR FORWARD TO AVOIDING DAMAGING THE TRANSMISSIONS.

Refitting

When refitting, tighten to the prescribed torque and apply the recommended grease to the threaded cone.

Recommended products

AGIP GREASE PV2 Grease for control levers on the engine

White anhydrous-calcium based grease to protect roller bearings; temperature range between -20 ° C and +120 °C; NLGI 2; ISO-L-XBCIB2

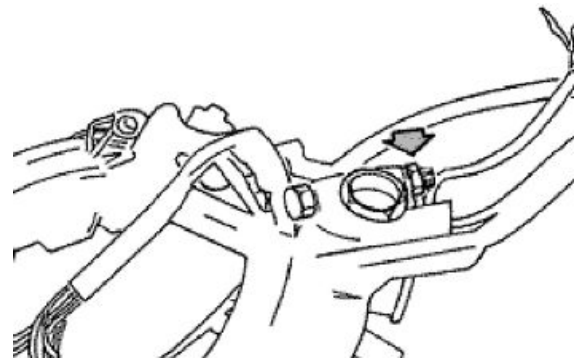

Locking torques (N*m)

Locking torque: 65 to 70 N*m

Front fork

Removal

- Remove the front brake calliper.
- Remove the odometer cable from the reduction gear box.
- Remove the front mudguard.
- Remove the handlebar.

After removing the steering ring-nut using the special tool, lean the vehicle on one side and extract the steering tube.

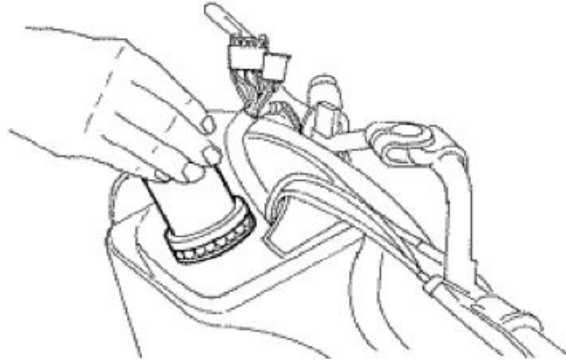

Specific tooling

020055Y Wrench for steering tube ring nut

See also

[Handlebar](#)
[Front mudguard](#)
[Front
brake calliper](#)

Overhaul

Removing damper

- Remove screw 1 fixing the screw to the stem and remove the stanchion heating it if necessary with the specified heater, then remove sealing ring 2 and seeger 3.
 - Using nut 4, remove the spring stem and bushing.
- The damper is an integral part of the stem and cannot therefore be overhauled, so if you need to work on the damper (loss of fork oil), carry out the operations mentioned above and replace the shock absorber-stem unit.

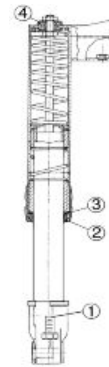

When refitting, tighten to the prescribed torque and apply the recommended grease to the threadlock nut.

Specific tooling

020150Y Air heater support

020151Y Air heater

Recommended products

Loctite 243 Medium strength threadlock

Loctite 243 medium-strength threadlock

Locking torques (N*m)

Stud-stanchion fixing screw 20 to 25 N*m Nut tightening torque 20 to 25 N*m

Replacing sealing ring

- Remove the wheel axle.
- Remove the screw (4).
- Remove the stanchion (3).
- Remove the dust guard (1).
- Insert the new sealing ring after lubricating the inside parts of the ring and paying attention not to damage it.
- Insert the stanchion applying the recommended product to the clean surface.
- Lock the screw (4).

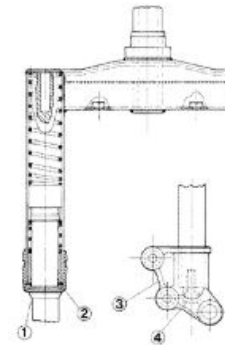

Recommended products

Loctite 243 Medium strength threadlock

Loctite 243 medium-strength threadlock

Removing stanchion bracket

- Remove the dust guard (1) using a screwdriver to prise it out.
- Remove the seeger (2) and remove the power pipe.

N.B.

GREASE THE SPRINGS AND THE BUSHINGS BEFORE REFITTING, WITH A SMALL QUANTITY OF GREASE (AROUND 3 GR.)

Recommended products

AGIP GREASE MU3 Grease for odometer transmission gear case

Soap-based lithium grease with NLGI 3; ISO-L-XBCHA3, DIN K3K-20

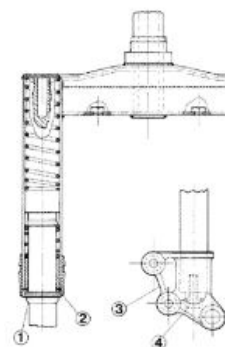

Refitting

Lubricate the seats and the balls with the grease recommended.



- Lock at the prescribed torque and turn the key anticlockwise by 90° to 100°.

Specific tooling**020055Y Wrench for steering tube ring nut****Recommended products****AGIP GREASE PV2 Grease for control levers on the engine**

White anhydrous-calcium based grease to protect roller bearings; temperature range between -20 °C and +120 °C; NLGI 2; ISO-L-XBCIB2

Locking torques (N*m)**Locking torque: 50 to 60 Nm**

Steering column

Removal**Removing upper and lower frame housing**

- Only remove the seats if it is strictly necessary.
- Using the special tool remove the upper fifth wheel seat by putting the special tool into the lower part of the headstock as indicated in the figure.
- By inserting the punch into the top of the tube, remove the lower fifth wheel seat from the headstock.

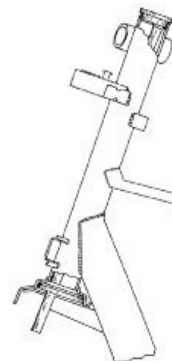
**Specific tooling****020004Y Punch for removing fifth wheels from headstock**

Refitting**Refit lower and upper area on the frame**

- Using the special tool, refit the upper and lower bearing seats on the headstock.

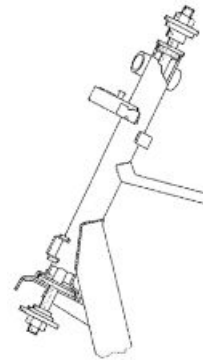
Specific tooling**001330Y Tool for fitting steering seats**

Steering bearing

Removal**Overhaul fifth wheel housing on fork**

Check the condition of the fifth wheel and the fifth wheel seat on the fork (steering tube). Replace if there are faults.

- Support the fork properly.
- Using the special tool, remove the fifth wheel seat on the steering tube as shown in the photograph by applying small mallet blows.

**Specific tooling****020004Y Punch for removing fifth wheels from headstock**

Always use a new fifth wheel seat on refitting.

- Using the special tool, refit the fifth wheel seat with the aid of a few mallet blows and bring it as far as the stop shown in the photo.

Specific tooling**006029Y Punch for fitting fifth wheel seat on steering tube**

Removing steering lock nut

- Remove the handlebar.
- Remove the bearing of steering ring nut using the specific tool.

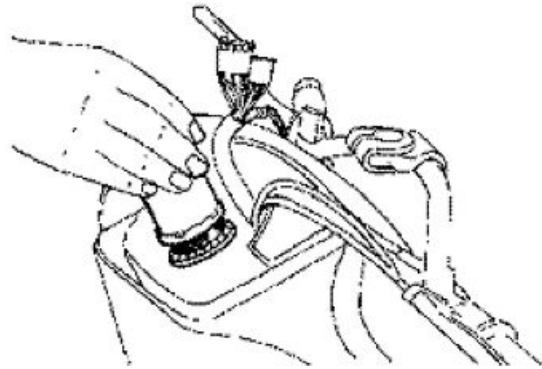
Specific tooling**020055Y Wrench for steering tube ring nut****See also**[Handlebar](#)**Refitting****Refit steering lock nut**

- After locking the first ring nut in place, lock the second ring nut using a specific tool.

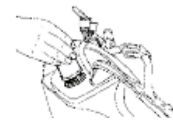
Specific tooling**020055Y Wrench for steering tube ring nut****Locking torques (N*m)****Locking torque: 30 to 40 Nm****Rear****Removing the rear wheel**

- Remove the wheel loosening the five clamps.



Refitting the rear wheel

- On refitting, tighten to the prescribed torque in a cross over pattern.

Locking torques (N*m)

Rear wheel: 20 - 25 Nm

Shock absorbers

Removal

To replace the shock absorber, simply remove the door to access the tool bag and remove the shock absorber / chassis nut. Then remove the shock absorber / engine anchor bolt.

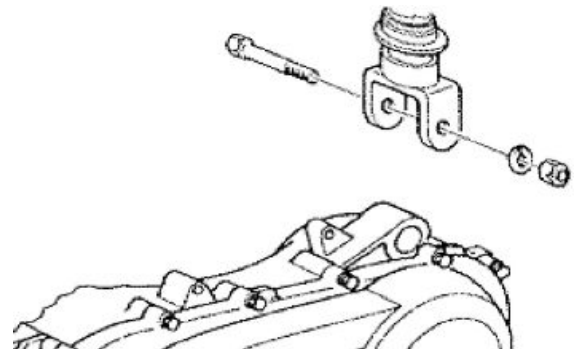
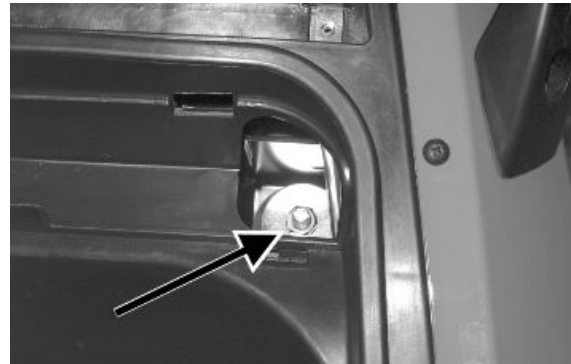

Refitting

When refitting, tighten the shock absorber/frame anchorage nut and the shock absorber/engine pin at the prescribed torque.

Locking torques (N*m)

Shock absorber/frame nut torque 20 to 25 Nm Shock absorber/engine pin torque 33 to 41 N-m

Centre-stand

Expulsion of kickstand bracket fastening pin

- Remove the stand support bracket from the engine.
- Drill a 5 mm hole in the bracket so that the pin «P» can come out.

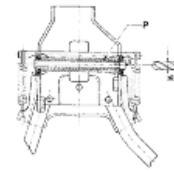

Fitting and caulking the kickstand pin to the bracket

- Caulk the end of the pin «P» between the two punches shown in the figure.
- After caulking it must be possible for the stand to turn freely.

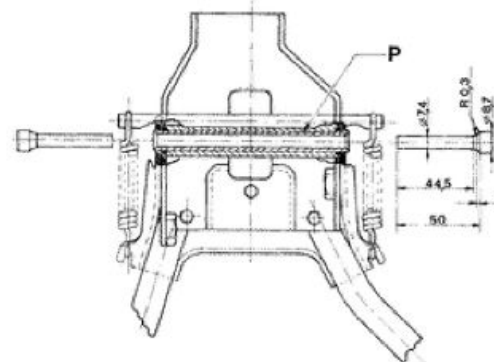

N.B.

UPON REFITTING USE NEW O-RING AND PIN, GREASE THE SPRING ATTACHMENTS AND THE PIN.

Replace complete kickstand

- Work on the screws shown in the figure.
- When refitting, secure to the prescribed torque.

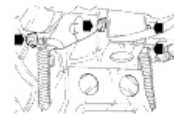

Locking torques (N*m)

Stand screw torque 18.5 to 19 Nm

INDEX OF TOPICS

BRAKING SYSTEM

BRAK SYS

Rear brake calliper

Removal

- Disconnect the hydraulic union collecting the oil in an appropriate container.
- Loosen the two support calliper clamps.



Front brake calliper

Removal

- Check that the brake piping, gasket and fitting are in good condition. If you see any oil on the brake calliper and/on the components of the system, it is necessary to replace them.
- - Disconnect the oil line from the calliper, collecting the oil in a container.
- - Remove the two clamps highlighted in the diagram.

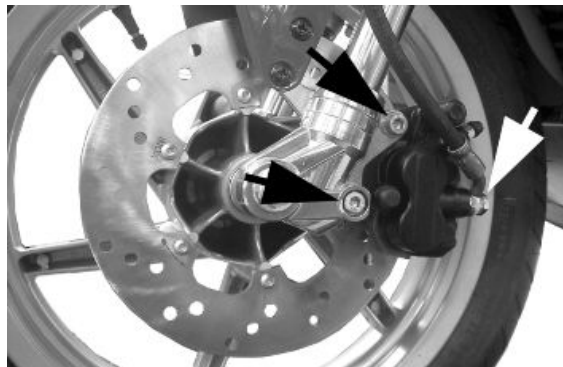

Overhaul

Proceed as follows:

- 1) remove the two male hexagonal screws (1) and take out the two pads (10);
- 2) remove the two male hexagonal screws (2) and remove the reaction plate (3);
- 3) take out the fixed plate (4) from the guide;
- 4) remove the internal elements from the floating body (5) with the help of short blows of com-

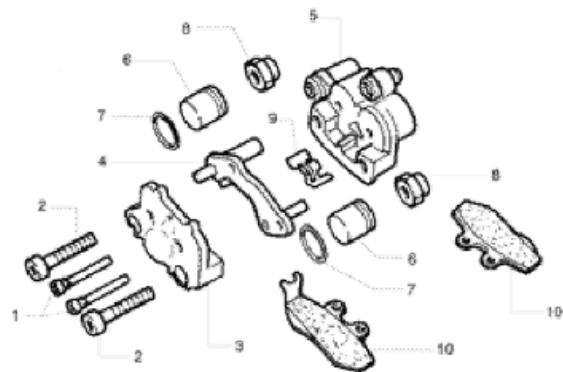

pressed air through the brake fluid pipe in order to facilitate the expulsion of pistons (6).

5) Check:

- that the plates and the body are whole and in good condition;
- that the cylinder and the floating body of the calliper do not show signs of scratches or erosion, otherwise replace the entire calliper;
- that the guides of the fixed plate are not scratched or eroded, otherwise replace the entire plate;
- that the brake pad check spring works properly.

Reassembly

- 1) insert the pistons (6) and the sealing rings (7) in the body;
- 2) place the guide rubbers (8) and refit the fixed plate (4);
- 3) assemble the reaction plate (3) tightening the screws (2), insert the brake pad check spring (9) and then the pads, fixing them with the corresponding screws (1);
- 5) place the calliper on the disc and lock it to the strut by tightening the fixing screws;
- 6) fix the pipe joint on the calliper at the prescribed torque.

Functioning

This is a floating type calliper.

It takes advantage of the action and reaction principle to obtain the thrust for both pads.

The body and the reaction plate body work integrally and can move axially with respect of the fixed plate that is integral to the strut.

The pistons, forced by pressure to push the pad to the disk, cause the reaction plate to push in turn the other pad towards the disc.

The brake pad lock spring

1. Pad fixing screws
2. Reaction plate fixing screws
3. Reaction plate

4. Fixed plate
5. Floating body
6. Piston
7. Piston sealing rings
8. Guide protection rubbers
9. Brake pad check spring
10. Pads

CAUTION

ALL THE SEALS AND GASKETS MUST BE REPLACED EVERY TIME THE CALLIPER IS SERVICED.

Locking torques (N*m)

Calliper tightening screw 24 ÷ 27 Brake fluid pipe-calliper fitting 19 ÷ 24

Refitting

- Refit the pincer on the support and tighten the screws at the prescribed torque.
- Refit the tube complete with fitting with new copper gaskets.
- Bleed the air from the system.

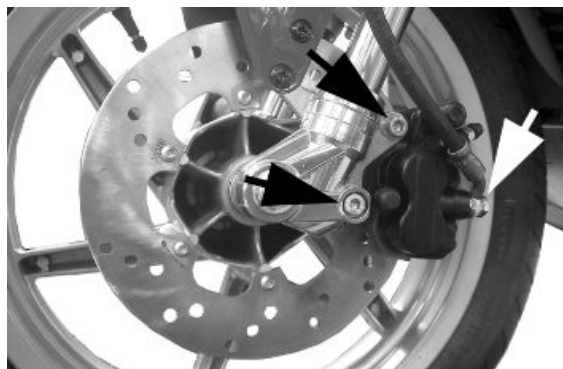
**Locking torques (N*m)**

Brake fluid tube calliper 20 ÷ 25 Nm Fastening screws calliper to the crankcase 20 - 25 Oil bleed screw 7 to 10 Nm

Front brake disc**Removal**

- Remove the front wheel loosening the axle clamp.
- Remove the six fastenings of the disc.

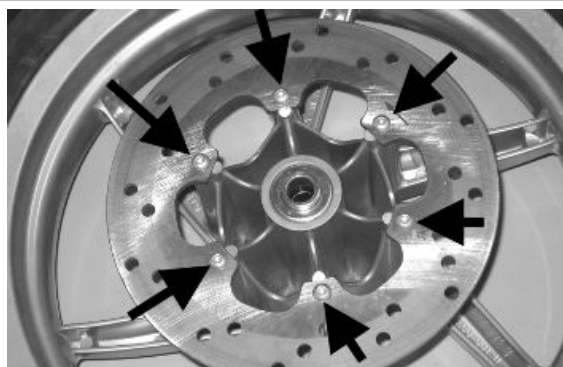

Refitting

-When refitting, position the disc correctly making sure that it rotates in the right direction.

Locking torques (N*m)

Disc tightening screw 8 - 12

Disc Inspection

- Use the micrometer to check the thickness of the disc as shown in the photograph



Characteristic

Standard thickness:

4 +02-01mm

- Using the appropriate tool, measure how much the disc protrudes when the wheel is fitted properly. The protrusion, measured near the external edge of the disc, must be less than 0.1 mm.
- If a value is measured other than the specified value, remove the front wheel (Front/Rear Suspension chapter) and check the protrusion of the disc. Maximum permissible out of true is 0.1 mm. If the value measured is greater, replace the disc and repeat the check.
- If the problem persists, check and replace the wheel hub if necessary.



Specific tooling

020335Y Magnetic support for dial gauge

Front brake pads

Removal

Proceed as follows:

- Remove the front calliper.
- Loosen the two pins shown in the figure that lock the two pads.
- Remove the pads, being careful with the pad spring clamp.
- Check the thickness of the pads.



Characteristic

Minimum value

1.5 mm

See also

[Front](#)
brake calliper

Refitting

To fit, proceed as follows:

- Insert the two pads in the callipers.
- Screw the two pad lock pins to the correct torque, and apply the recommended product.
- Fit the calliper on its support, tightening the two screws to the prescribed torque.

N.B.

IF IT IS NOT POSSIBLE TO CORRECTLY POSITION THE CALLIPER ON THE DISC DURING FITTING, GENTLY EXPAND THE PADS.

Recommended products

Loctite 243 Medium strength threadlock

Loctite 243 medium-strength threadlock

Locking torques (N*m)

Screw tightening calliper to the support 20 ÷ 25 Pad fastening pin 19.6 ÷ 24.5

Fill

-Once the bleed valve is closed, fill the system with brake liquid to the maximum level.

-Undo the bleed screw.

-Apply the tube of the special tool to the bleed screws.

When bleeding it is necessary to fill the oil tank in continuation while working with a MITYVAC pump on the bleed screws until no more air comes out of the system.

The operation is finished when just oil comes out of the bleed screws.

-Do up the bleed screw.

-When the operation is over, tighten up the oil bleed screw to the prescribed torque.

N.B.

IF AIR CONTINUES TO COME OUT DURING PURGING, EXAMINE ALL THE FITTINGS: IF SAID FITTINGS DO NOT SHOW SIGNS OF BEING FAULTY, LOOK FOR THE AIR INPUT AMONG THE VARIOUS SEALS ON THE PUMP AND CALLIPER PISTONS.

CAUTION

- DURING THE OPERATIONS, THE VEHICLE MUST BE ON THE STAND AND LEVEL.

N.B.

DURING PURGING FREQUENTLY CHECK THE LEVEL TO PREVENT AIR GETTING INTO THE SYSTEM THROUGH THE PUMP.

WARNING

- BRAKING CIRCUIT FLUID IS HYGROSCOPIC. IT ABSORBS HUMIDITY FROM THE SURROUNDING AIR.

IF THE LEVEL OF HUMIDITY IN THE BRAKING FLUID EXCEEDS A GIVEN VALUE, BRAKING EFFICIENCY WILL BE REDUCED.

THEREFORE, ALWAYS USE FLUID FROM SEALED CONTAINERS.

UNDER NORMAL DRIVING AND CLIMATIC CONDITIONS YOU SHOULD CHANGE THIS LIQUID EVERY TWO YEARS.

IF THE BRAKES ARE USED INTENSELY AND/ OR IN HARSH CONDITIONS, CHANGE THE FLUID MORE FREQUENTLY.

CAUTION

WHEN CARRYING OUT THE OPERATION, BRAKE FLUID MAY LEAK FROM BETWEEN THE BLEED SCREW AND ITS SEAT ON THE CALLIPER.

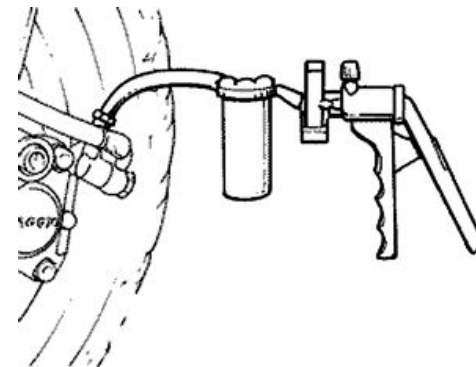

CAREFULLY DRY THE CALLIPER AND DE-GREASE THE DISC SHOULD THERE BE OIL ON IT.

Specific tooling

020329Y MityVac vacuum-operated pump

Recommended products

AGIP BRAKE 4 Brake fluid

FMVSS DOT 4 Synthetic fluid

Locking torques (N*m)

Oil bleed screw 8÷12

Front brake pump

- After removing the front and rear handlebar covers, act on the two stand fixing points (see the figure).
- Disconnect the tube, collecting the brake oil in a container.

- On refitting, perform the operation in reverse.
- Tighten the hydraulic line to the prescribed torque and bleed the system.

Locking torques (N*m)

Brake fluid pump - hose fitting 20 ÷ 25 Nm

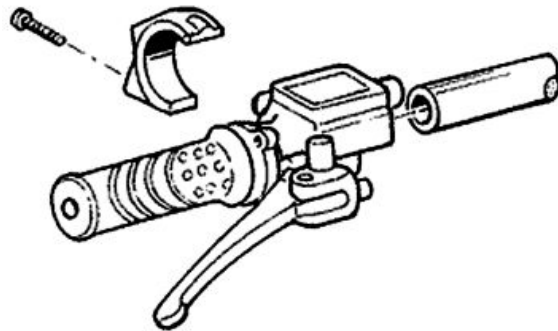

INDEX OF TOPICS

COOLING SYSTEM

COOL SYS

System bleed

1. Fill the circuit through the expansion tank to the maximum level.
2. Fasten the rubber line to the drain fitting on the head and thread it into the expansion tank mouth..
3. Loosen the fitting and restore the tank level.
4. Start up the engine and wait until only coolant exits from the line, then tighten the fitting on the head..
5. Turn off the engine, restore the level of liquid to the maximum level, then close the expansion tank..
6. Heat up the engine to normal operating temperature in order to eliminate any air formation in the main lines..
7. Stop the engine and let it cool, then check that the level of coolant in the expansion tank to the maximum;; refill it.



Water pump - overhaul

- Remove the rpm sensor /coolant delivery hose clamp
- Remove the transmission cover
- Remove the mixer
- Position the tool as shown in the picture

N.B.

WHEN SECURING THE TOOL, PAY ATTENTION NOT TO OVERLOAD THE PLASTIC IMPELLER.

Specific tooling

020620Y Water pump impeller stop



- Remove the mixer/water pump drive-belt with the two crown wheels

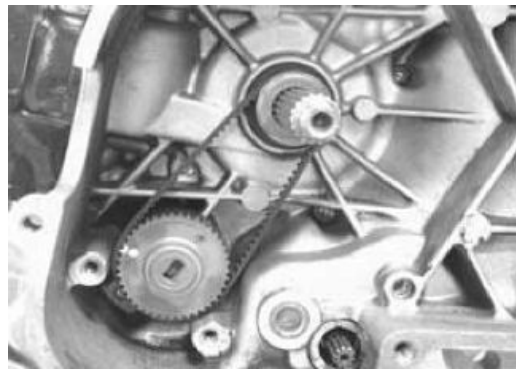

- Remove the snap ring of the pump bearing stay
- Remove the steel washer



- Using the air heater, warm up the crankcase in the area around the water pump bearings as shown in the picture.



- Using the special tool, loosen the impeller shaft turning the spanner clockwise (left-handed thread)
- As the thread is fully disengaged, extract the shaft using pliers.

Specific tooling

020169Y Water pump crankshaft fitting and removal spanner



-
- Using the special hook, remove the sealing ring from its housing as shown in the picture.

Specific tooling**020209Y Spring hook**

-
- Ensure the shaft is not abnormally worn and the bearings not noisy. Otherwise, replace shaft and bearings
 - Carefully clean oil seal and bearing housings



-
- Use a new oil seal to refit
 - Position the new oil seal on the special tool with the main lip facing the bearings as shown in the picture



-
- Lubricate the oil seal and push it home using the special tool as shown in the picture

Specific tooling**020168Y Water seal punch mount on half-crankcase**

Using the air heater, warm up the water pump bearing housing, without directing the air flow directly against the oil seal

- Lubricate the end of the water pump shaft on the oil seal side, using the recommended product.

Recommended products

AGIP GREASE MU3 Grease for odometer transmission gear case

Soap-based lithium grease with NLGI 3; ISO-L-XBCHA3, DIN K3K-20



- Insert the shaft, with bearings, into its housing by pushing and turning it at the same (turn anticlockwise for tightening)

- Turn it rapidly to the end of the threading.

- Should this operation prove difficult, do not carry on; instead, start over by reheating the crankcase

N.B.

FAILURE TO OBSERVE THIS RULE MAY RESULT IN DAMAGE TO THE THREAD OF THE COPPER INSERT ON THE IMPELLER, OR SEPARATION OF THIS FROM THE IMPELLER ITSELF.



Specific tooling

020169Y Water pump crankshaft fitting and removal spanner

See also

[Removal](#)

Thermostat

Removal

- Detach the coolant hose from the head, partially draining the system.
- Remove the cylinder head.
- Remove the two fixing screws and hence the thermostat.

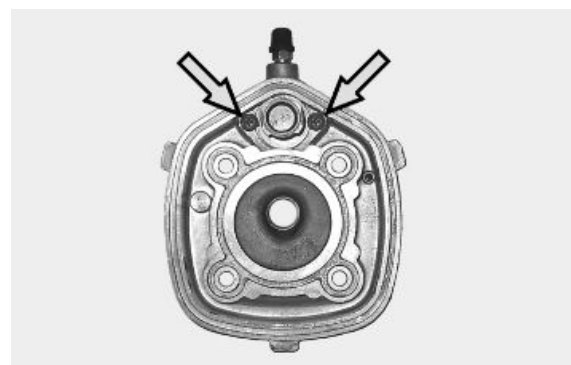

Check

1) Visually check that the thermostat is not damaged.

2) Fill a metallic container with approx. 1 litre of water.

Immerse the thermostat, and keep it in the centre of the bowl.

Immerse the multimeter temperature probe, and keep it close to the thermostat.

Heat up the bowl using the thermal gun.

Check the thermostat opening start temperature:

Heat up until the thermostat is completely open.

3) Replace the thermostat if not working properly.

CAUTION

TO EXECUTE THE TEST CORRECTLY, MAKE SURE NEITHER THE THERMOSTAT NOR THE THERMOMETER TOUCHES THE CONTAINER.

Specific tooling

020331Y Digital multimeter

020151Y Air heater

Characteristic

Thermostat check: Opening start temperature

60±2°C



Refitting

- Refit the thermostat onto the head, following the removal operations in the reverse order, and paying attention in inserting the groove on the thermostat on the reference on the head.





INDEX OF TOPICS

CHASSIS

CHAS

Seat

Lift the saddle and remove the screws indicated in the photograph

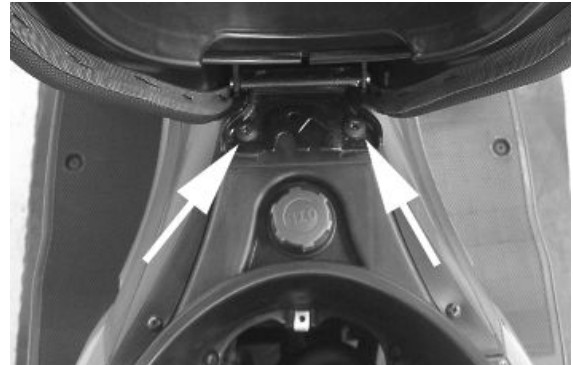

Rear handlebar cover

- Remove the front handlebar cover
- Remove the 3 screws indicated in the figure
- After disconnecting the wiring remove the rear handlebar.

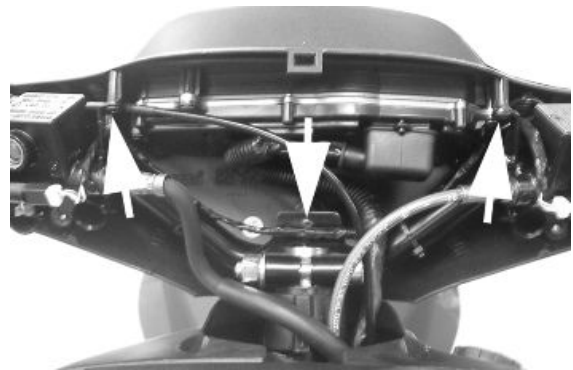
**See also**

[Front handlebar cover](#)

Headlight assy.

- Remove the front shield
- Remove the 2 screws indicated in the photograph at the back of the shield, then disconnect the wiring and remove the headlight assembly.

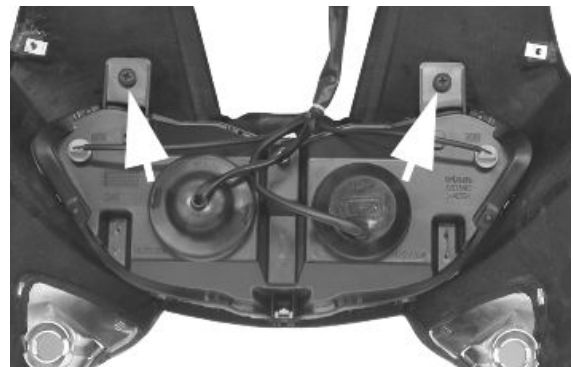
**See also**

[Legshield](#)

Frame central cover

Remove the saddle and the two screws indicated in the photograph.

- Remove the air ducts, then operate the screw indicated in photograph.

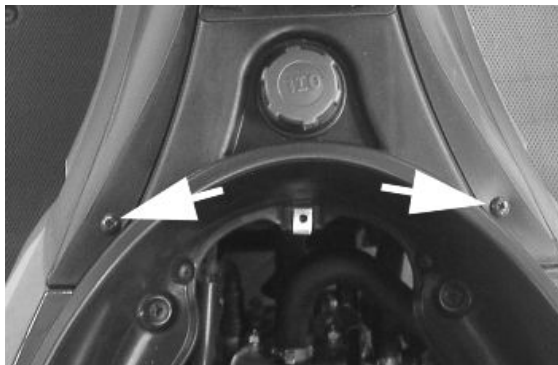

- Remove the ring nut of the fuel tank cap by unscrewing the 3 screws indicated in the photograph.

- Remove the filling hole unit of the fuel tank by loosening the 3 screws <A> indicated in the photograph and the metal clamp.

- Remove the screw indicated in the photograph, then remove the chassis central cover by pulling it upwards.



To fit, repeat the procedure in reverse order being careful to replace the metal clamp of the fuel tank filling hole.

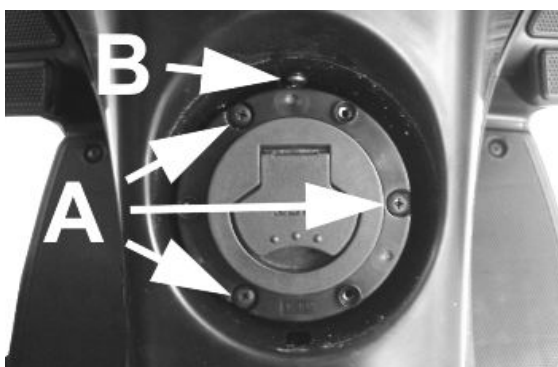

Legshield

- Remove the shield central cover.
- Remove the 2 screws shown in the photograph.
- Remove the 10 screws (5 per side) indicated in the photograph.
- Remove the 7 screws indicated in the photograph from the front wheel compartment.
- Lever on the plastic parts creating enough space to remove the 4 screws (2 per side) <A> indicated in the photograph.
- Remove the front shield after disconnecting the wiring of the front headlight assembly and of the taillights.

Assembly following the procedure in reverse order.

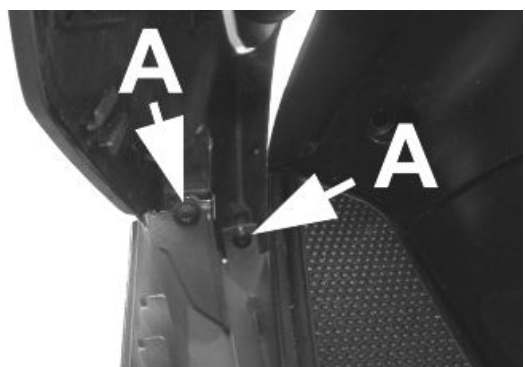
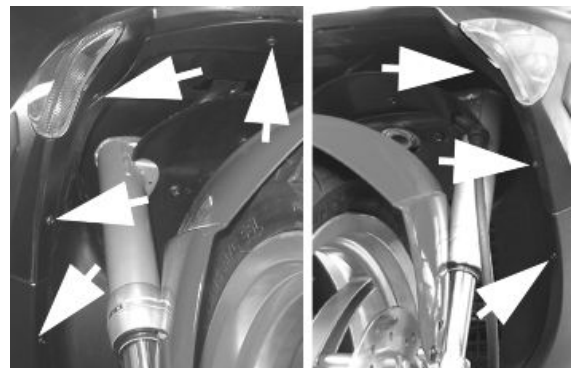
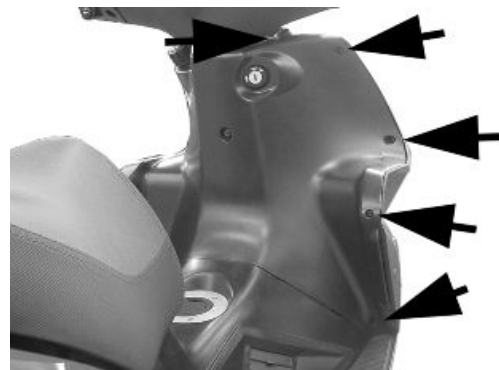
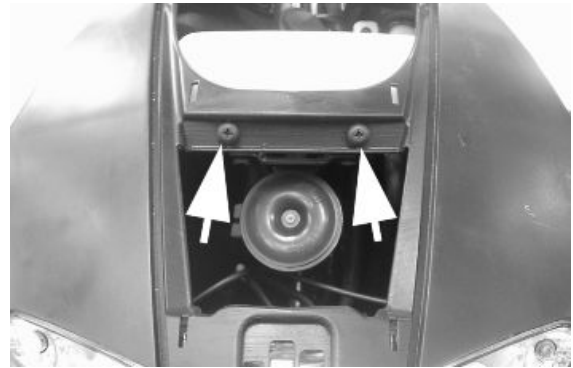

See also

[Front central cover](#)

Knee-guard

- Remove the central chassis cover.
- Remove the shield central cover and remove the supporting screws for the expansion tank.
- Remove the 10 screws (5 per side) of the shield back plate indicated in the photograph.
- Remove the central screw <A> indicated in the photo, then remove the shield back plate.

Follow the procedure in reverse order to refit.

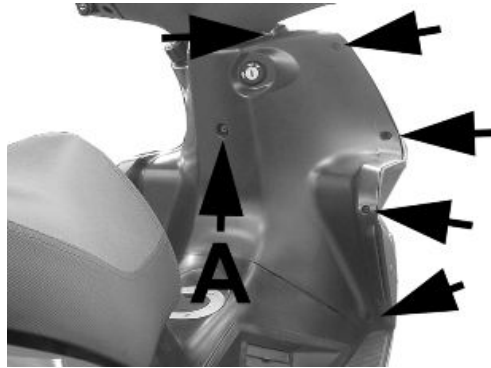

See also

[Frame central cover](#)

[Front central cover](#)

Removing the ignition key-switch when on *off*

- Remove the front shield and back shield.
 - Insert a small awl in the groove shown in the photo and pry up until the clamp is removed.
 - Remove the lock body.
- To fit, repeat the procedure in the reverse direction.



See also

[Legshield](#)

[Knee-guard](#)

Removing the ignition key-switch when on *lock*

- Remove the shield.
- Remove the switch of the key switch.
 - Make a hole on the block using a drill as shown in the figure.
 - Insert the wheel cylinder with the key and with the anchoring tab facing down halfway on the lock body taking care that the insertion phase of the key is oriented matching "ON" (the only position that enables the cylinder to get into the lock body); now

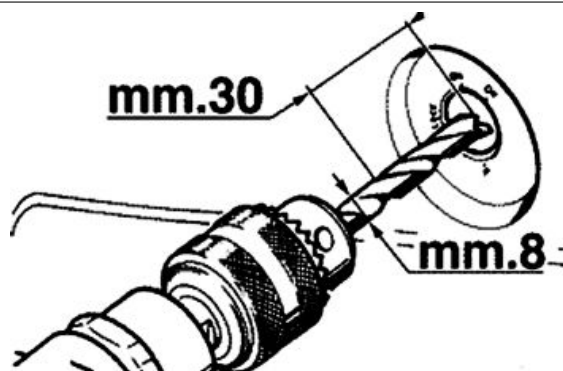

turn the key leftwards to "OFF" and at the same time press until the cylinder is completely in.

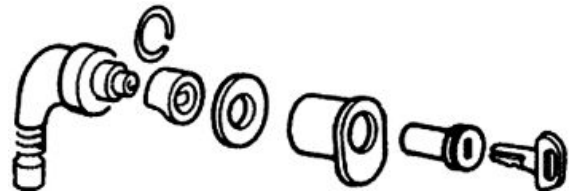

See also

[Knee-guard](#)
[Legshield](#)

Front wheel housing

- Remove the front fork;
- Unscrew the central stud of the wheel well at the frame;
- Disconnect the brake pipe to the pump and pull it out;;
- Remove the odometer transmission..



Taillight assy.

Remove the two screws and take out the whole unit.

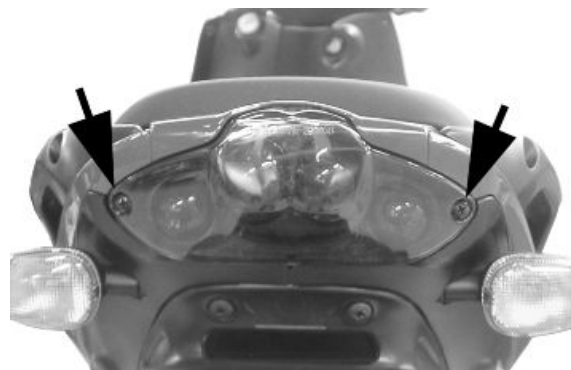

Footrest

Remove the 3 screws indicated in the figure and remove the footrest.



Side fairings

The side fairing consists of 3 parts as described in the figure.

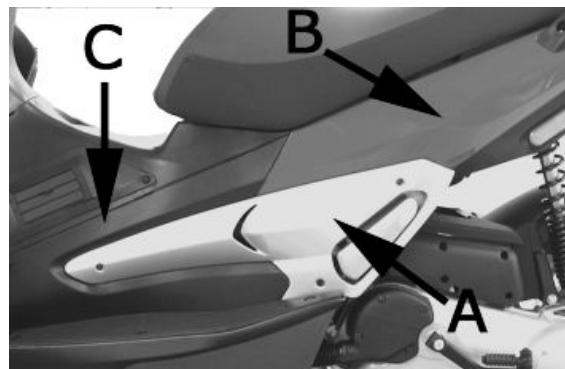

Fairing A

- Remove the 4 screws indicated in the figure and take out the casing.

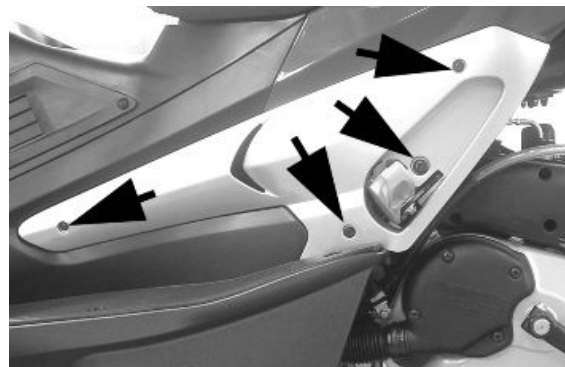

Fairing B

- Remove fairing A
- Remove the passenger handles.
- Remove the rear light assembly.
- Remove the license plate holder undoing the 4 screws indicated in the figure.
- Remove the screw of the rear wheel compartment.
- Remove the 2 screws indicated in the figure.



- Remove the screw located below the fairing **A**
- Pull out the fairing.

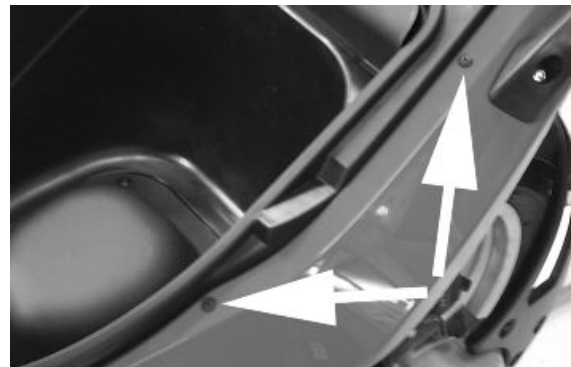
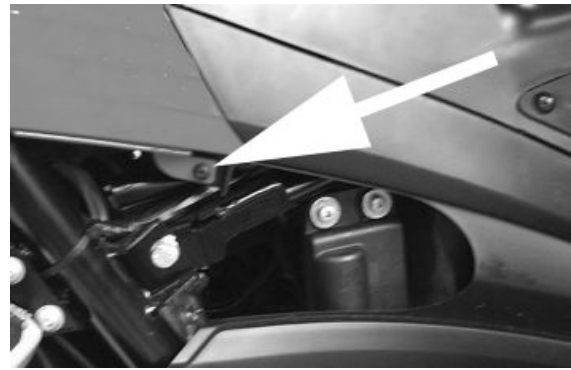

Fairing C

- Remove the central chassis cover.
- Remove the lateral fairings **A** and **B**.
- Remove the fairing by pulling it upwards.

Air filter

- Remove the protective crankcase of the carburettor by removing the four screws.
- Remove the two screws shown in the photo then disconnect the air manifold at the carburettor and remove it.

When refitting, be careful to correctly install the air manifold into the air filter housing.

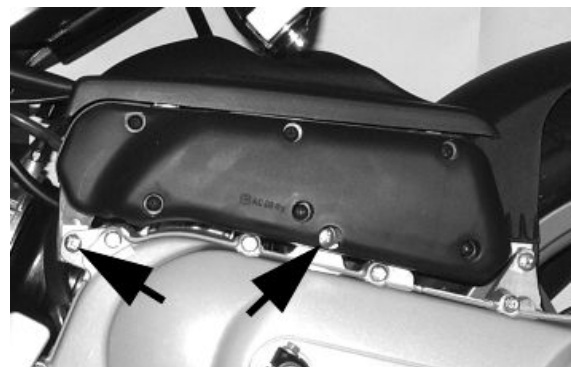

Helmet bay

- Remove the battery.
- Remove the saddle.
- Remove the rear central cover.
- Remove the side panels
- Remove the mix. oil reservoir cap.
- Remove the wiring found in the battery compartment.
- Disconnect the cable of the saddle opening device.
- Remove the 5 screws indicated in the figure located on the front part of the helmet compartment.
- Remove the 2 screws indicated in the figure located on the rear part of the helmet compartment.
- Remove the screw indicated in the figure located on the rear wheel compartment, and then remove the helmet compartment.

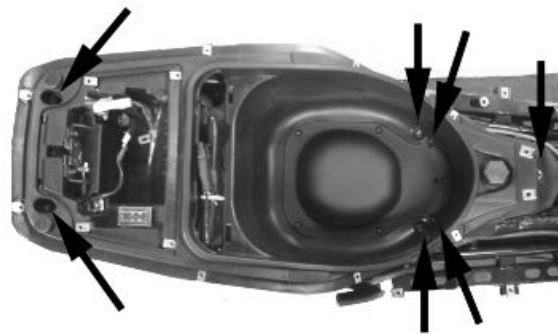

See also

[Seat](#)
[Side fairings](#)

Fuel tank

- Remove the central chassis cover.
- Remove the side fairings and the helmet compartment.
- Remove the screw <C> indicated in the figure at both sides.
 - Remove the bolt <A> and loosen the nut indicated in the figure.
 - Lift the chassis very gently, being careful with the cables affixed to it.
 - Disconnect the electrical connections and the fuel tank pipes when extracting the chassis.

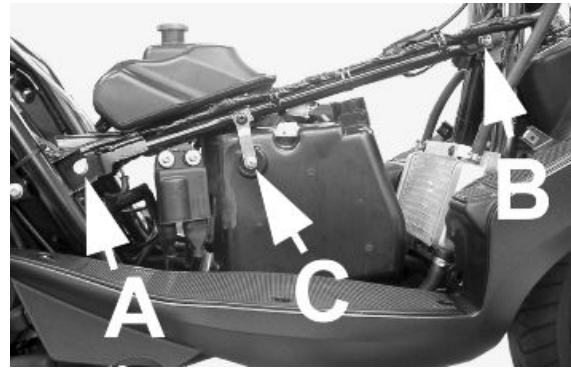
**N.B.**

this operation should preferably be carried out with the tank empty.

See also

[Frame central cover](#)

[Helmet bay](#)

[Side fairings](#)

Front mudguard

Loosen the four screws fixing the fender to the fork.

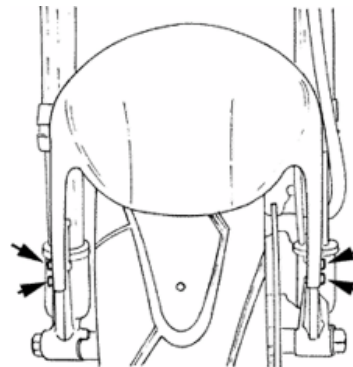

Radiator fan

- Set up a receptacle to collect coolant.
- Remove the fuel tank.
- Loosen the clamps and disconnect the 4 lines from the radiator.
- Remove the radiator by the 4 studs shown in the figure.

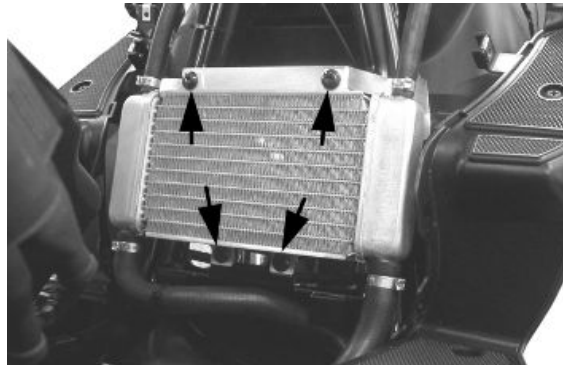

See also

Fuel tank
[Frame central cover](#)

Expansion tank

- Remove the front shield.
- Remove the screw indicated in the photograph.
- Remove the cap momentarily to disconnect it from the shield back plate by pulling it downwards.
 - Disconnect the expansion tank from the support anchored to the chassis.
 - Prepare a container to collect the coolant.
 - Remove the coolant in (top) and return (bottom) pipes.



Assembly following the procedure in reverse order.

See also

[Legshield](#)

Mixture oil tank

- Remove the helmet compartment.
 - Disconnect the connector of the oil gauge light and the oil pipe and remove the tank
-

Front central cover

- Remove the Gilera emblem placing a screwdriver in the emblem right groove.
- Remove the screw indicated in the photograph and remove the cover by pulling it upwards.



Battery

Dopo aver rimosso il coperchio batteria installare la batteria rispettando le polarità come mostrato in foto



Lower cover

- Remove the footrests.
- Remove the 4 screws (2 per side) indicated in the photograph of the front wheel compartment.
- Remove the two bottom screws (1 per side) of the shield back plate, then lever the plastic parts to reach the screws <A> indicated in the photograph.
- Remove the lower cover.

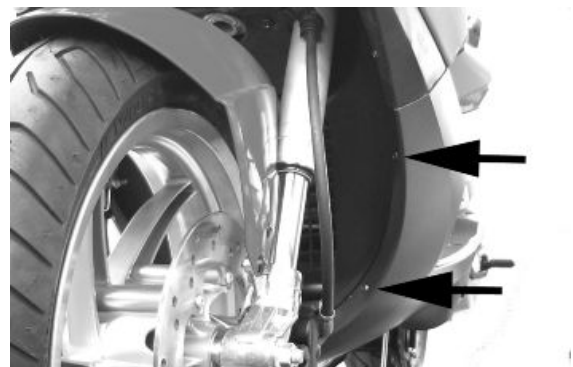

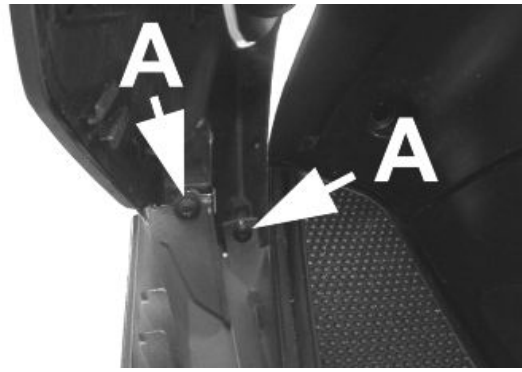

INDEX OF TOPICS

PRE-DELIVERY

PRE DE

Aesthetic inspection

Appearance check:

- Paintwork
 - Fitting of plastics
 - Scratches
 - Dirt
-

Tightening torques inspection

Lock check

- Safety locks
- clamping screws

Safety locks

Rear shock absorber upper fixing

Rear shock absorber lower fixing

Front wheel axle nut

Wheel hub nut

Frame - swinging arm bolt *

Swinging arm bolt - Engine

Engine arm pin - Frame arm

Handlebar lock nut

Steering lower ring nut

Upper steering ring nut

Electrical system

Electrical system:

- Main switch
 - Headlamps: high beam, low beam, position and parking lights and the respective warning lights
 - Adjusting the headlights according to the regulations currently in force
 - Rear light, parking light, stop light
 - Front and rear stop light switches
 - Turn indicators and their warning lights
 - Instrument panel lights
 - Instrument panel: fuel and temperature indicator
 - Instrument panel warning lights
 - Horn
 - Starter
-

CAUTION

TO ENSURE MAXIMUM PERFORMANCE, THE BATTERY MUST BE CHARGED BEFORE USE. INADEQUATE CHARGING OF THE BATTERY WITH A LOW LEVEL OF ELECTROLYTE BEFORE IT IS FIRST USED SHORTENS BATTERY LIFE.

WARNING

BEFORE RECHARGING THE BATTERY, REMOVE THE CAPS OF EACH CELL. KEEP THE BATTERY AWAY FROM NAKED FLAMES OR SPARKS WHILE IT IS CHARGED. REMOVE THE BATTERY FROM THE SCOOTER, DISCONNECTING THE NEGATIVE TERMINAL FIRST.

CAUTION

WHEN INSTALLING THE BATTERY, ATTACH THE POSITIVE LEAD FIRST AND THEN THE NEGATIVE LEAD.

WARNING

BATTERY ELECTROLYTE IS TOXIC AND IT MAY CAUSE SERIOUS BURNS. IT CONTAINS SULPHURIC ACID. AVOID CONTACT WITH EYES, SKIN AND CLOTHING.

IN CASE OF CONTACT WITH EYES OR SKIN, RINSE WITH ABUNDANT WATER FOR ABOUT 15 MINUTES AND SEEK MEDICAL ATTENTION AT ONCE.

IF IT IS SWALLOWED, IMMEDIATELY DRINK LARGE QUANTITIES OF WATER OR VEGETABLE OIL. SEEK IMMEDIATE MEDICAL ATTENTION.

BATTERIES PRODUCE EXPLOSIVE GAS; KEEP THEM AWAY FROM NAKED FLAMES, SPARKS AND CIGARETTES. IF THE BATTERY IS CHARGED IN A CLOSED PLACE, TAKE CARE TO ENSURE ADEQUATE VENTILATION. ALWAYS PROTECT YOUR EYES WHEN WORKING CLOSE TO BATTERIES.

KEEP OUT OF THE REACH OF CHILDREN

CAUTION

NEVER USE FUSES WITH A CAPACITY HIGHER THAN THE RECOMMENDED CAPACITY. USING A FUSE OF UNSUITABLE RATING MAY SERIOUSLY DAMAGE THE VEHICLE OR EVEN CAUSE A FIRE.

Levels check

Level check:

- Hydraulic braking system fluid level.
 - Rear hub oil level
 - Engine coolant level.
-

Road test

Test ride

- Cold start
 - Instrument operations
 - Response to the throttle control
 - Stability on acceleration and braking
 - Rear and front brake efficiency
 - Rear and front suspension efficiency
 - Abnormal noise
-

Static test

Static control after the test ride:

- Starting when warm
- Starter operation
- Minimum hold (turning the handlebar)
- Uniform turning of the steering
- Possible leaks

CAUTION

CHECK AND ADJUST TYRE PRESSURE WITH TYRES AT AMBIENT TEMPERATURE.

CAUTION

NEVER EXCEED THE RECOMMENDED INFLATION PRESSURES OR TYRES MAY BURST.

Functional inspection

Functional check up:

Braking system (hydraulic)

- Lever travel

Braking system (mechanical)

- Lever travel

Clutch

- Proper functioning check

Engine

- Throttle travel check

Others

- Check documentation
 - Check the frame and engine numbers
 - Tool kit
 - License plate fitting
 - Check locks
 - Check tyre pressures
 - Installation of mirrors and any accessories
-

INDEX OF TOPICS

TIME

TIME

This section is devoted to the time necessary to carry out repairs.

The description and code for each operation is indicated.



Engine

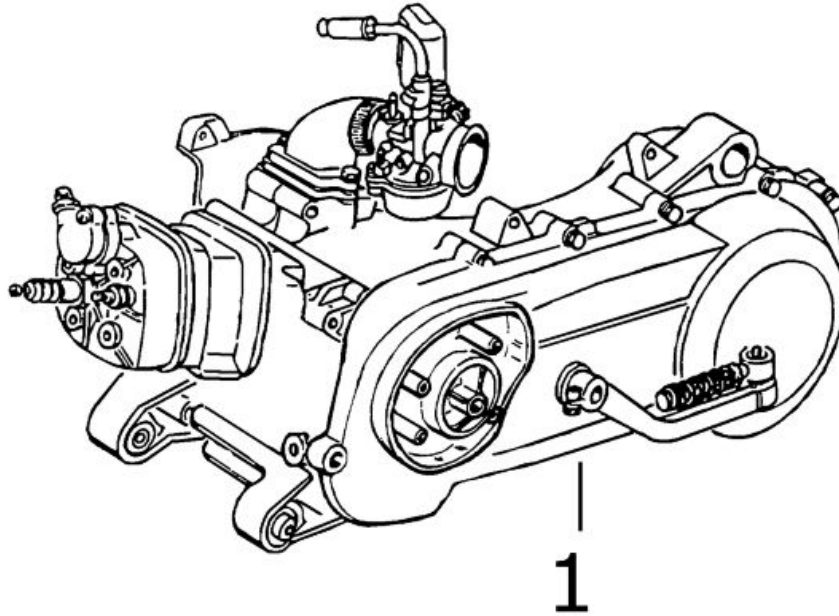

ENGINE

	<u>Code</u>	<u>Action</u>	<u>Duration</u>
1	001001	Engine to chassis - Replacement	

Crankcase

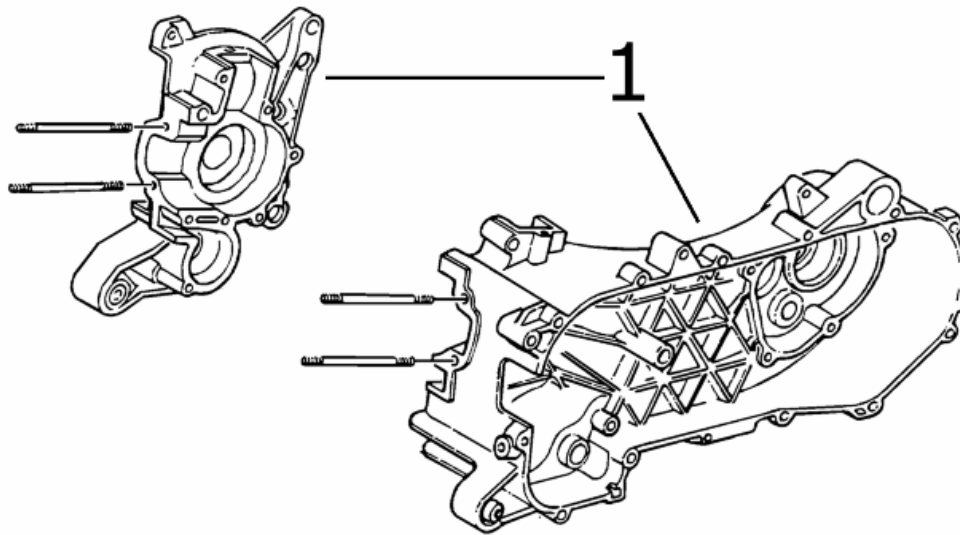

CRANKCASE

	Code	Action	Duration
1	001133	Engine crankcase - Replacement	

Crankshaft

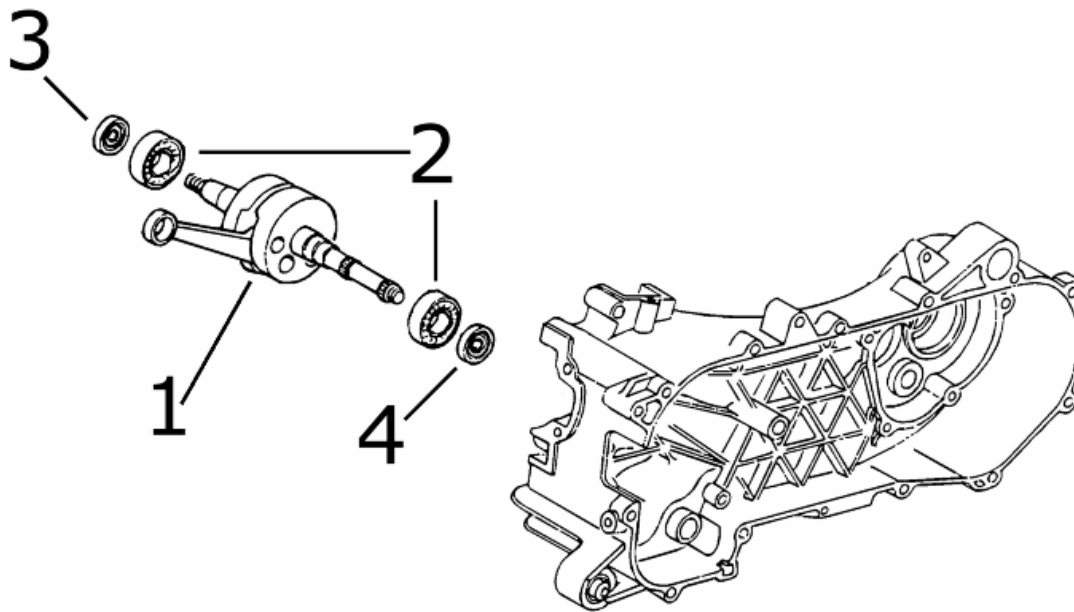

CRANKSHAFT

	Code	Action	Duration
1	001117	Crankshaft - Replacement	
2	001118	Main bearings - Replacement	
3	001099	Oil seal, flywheel side - Replacement	
4	001100	Oil seal, clutch side - Replacement	

Cylinder assy.

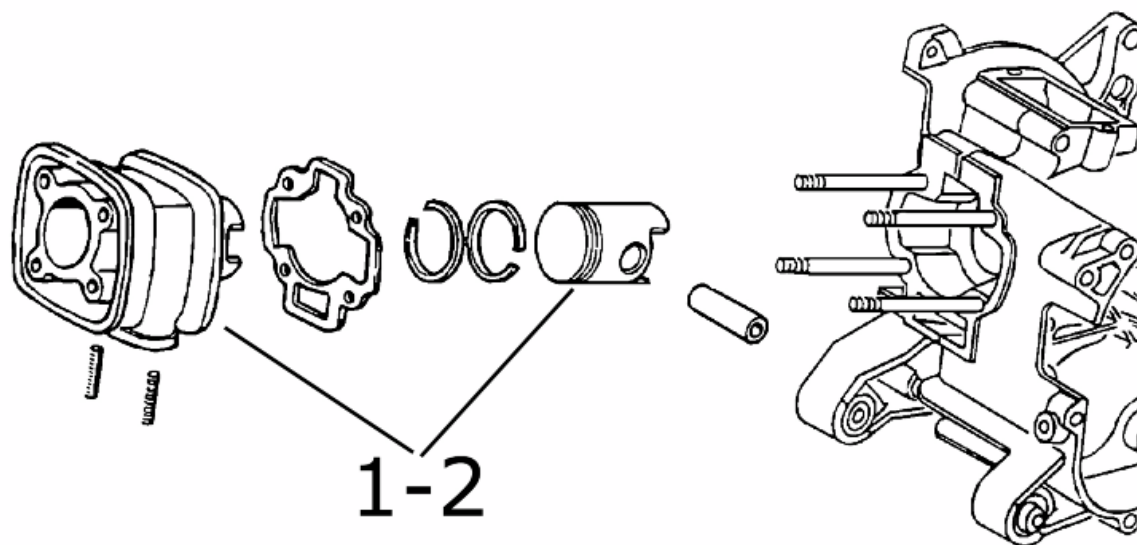

CYLINDER / PISTON

	Code	Action	Duration
1	001002	Cylinder piston - Replacement	
2	001107	Cylinder / piston - Inspection / cleaning	

Cylinder head cover

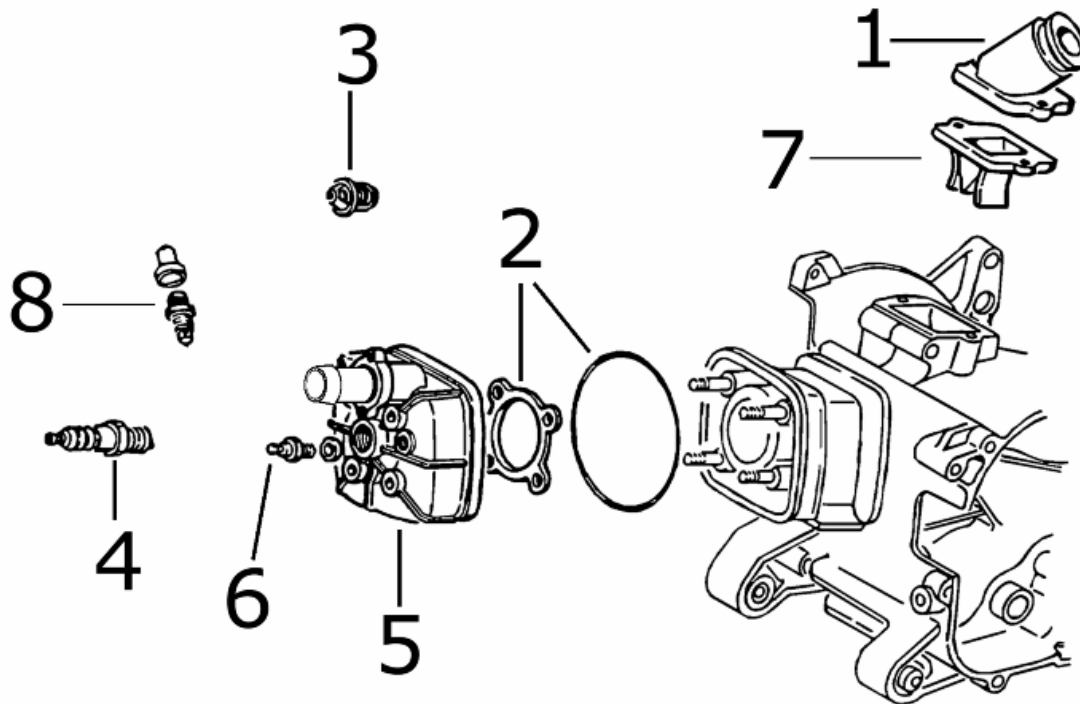
HEAD ASSEMBLY

	Code	Action	Duration
1	001013	Intake manifold - Replacement	
2	001056	Head gasket - change	
3	001057	Thermostat - Replacement	
4	001093	Spark plug - Replacement	
5	001126	Head - Replacement	
6	007010	Bleed valve - Replacement	
7	001178	Disc pack - Replacement	
8	001083	Thermistor - Replacement	

Driven pulley

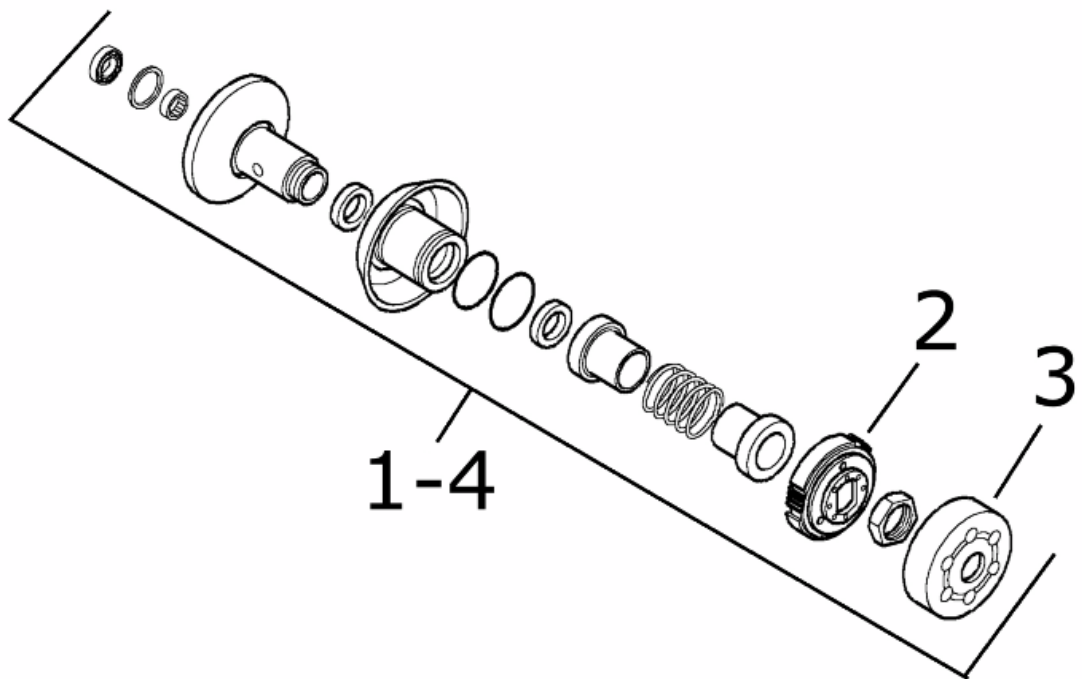

DRIVEN PULLEY

	Code	Action	Duration
1	001110	Driven pulley - Replacement	
2	001022	Clutch - Replacement	
3	001155	Clutch bell housing - Replacement	
4	001012	Driven pulley - Service	

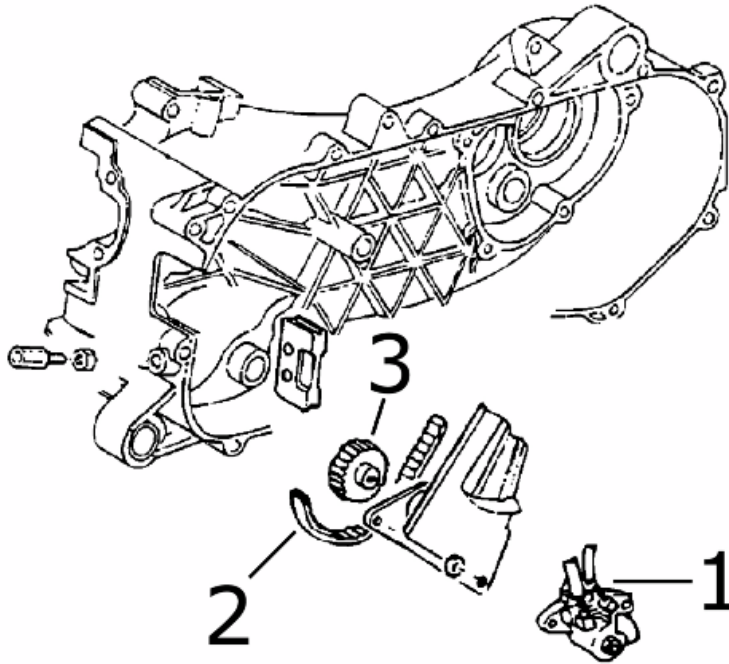
Oil pump**OIL MIX PUMP**

	Code	Action	Duration
1	001018	Mixer - Replacement	
2	001019	Mixer belt - replacement	
3	001028	Mix movement gear socket - Replacement	

Final gear assy.

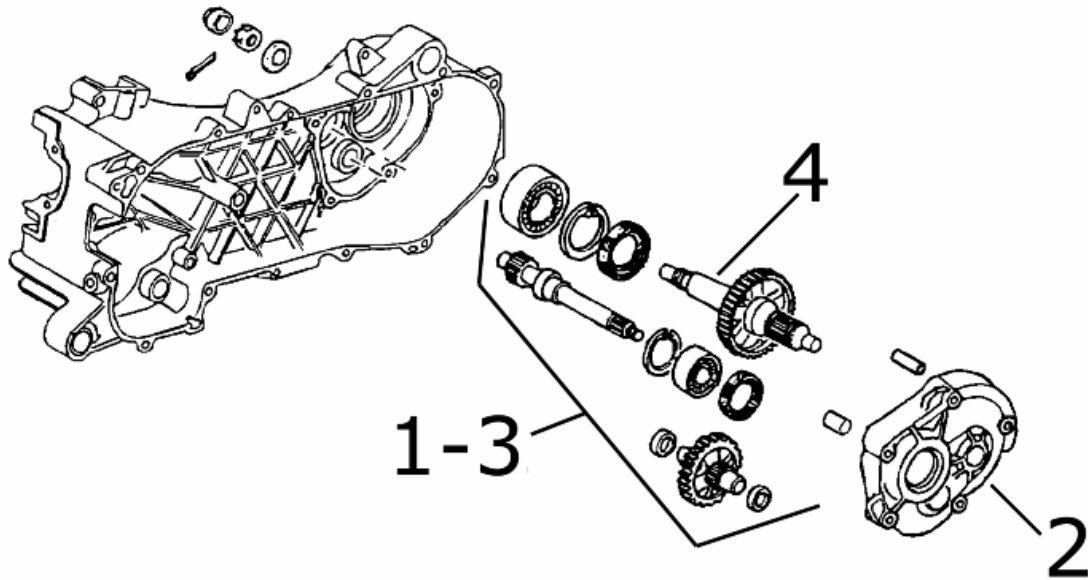

FINAL REDUCTION GEAR

	Code	Action	Duration
1	001010	Geared reduction unit - Service	
2	001156	Gear reduction unit cover - Replacement	
3	003065	Gear box oil - Replacement	
4	004125	Rear wheel axle - Replacement	

Driving pulley

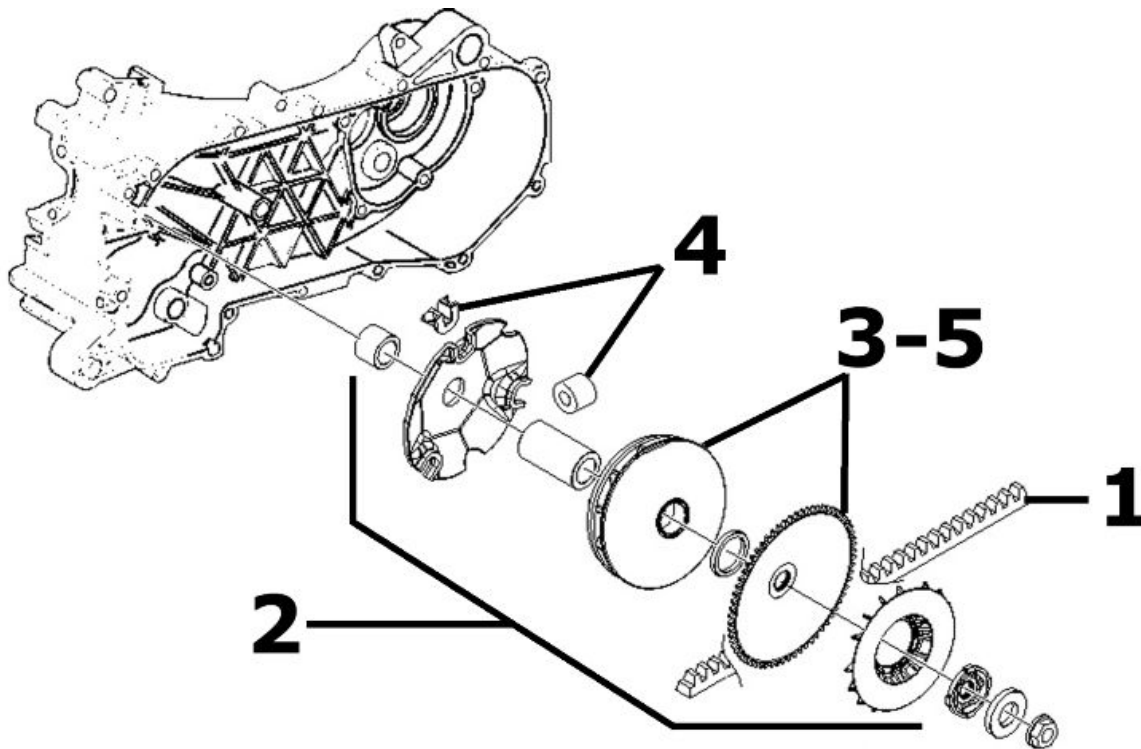
**PULEGGIA MOTRICE**

	Code	Action	Duration
1	001011	Driving belt - Replacement	
2	001066	driving pulley - Replacement	
3	001006	rear-view pulley - Service	
4	001177	Variator rollers / shoes - Replacement	
5	001086	Driving half-pulley - replace	

Transmission cover

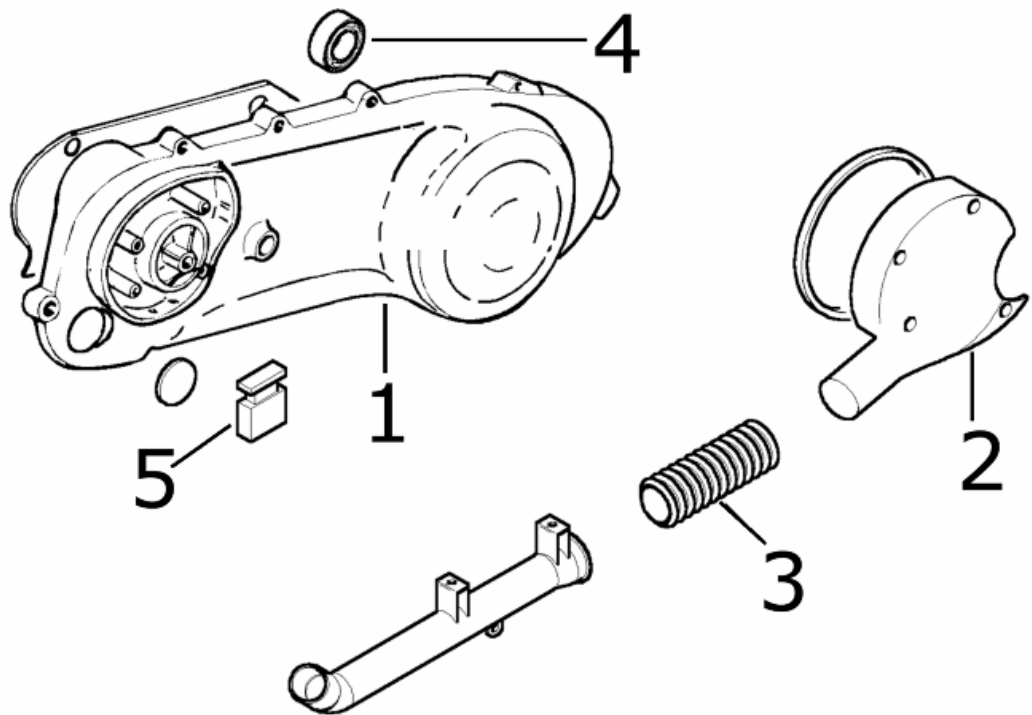

TRANSMISSION COVER

	Code	Action	Duration
1	001096	Transmission crankcase cover - Replacement	
2	001131	Transmission air intake - Replacement	
3	001132	Transmission air inlet pipe - Replacement	
4	001135	Transmission cover bearing - Replacement	
5	004179	Stand buffer - Replacement	

Water pump

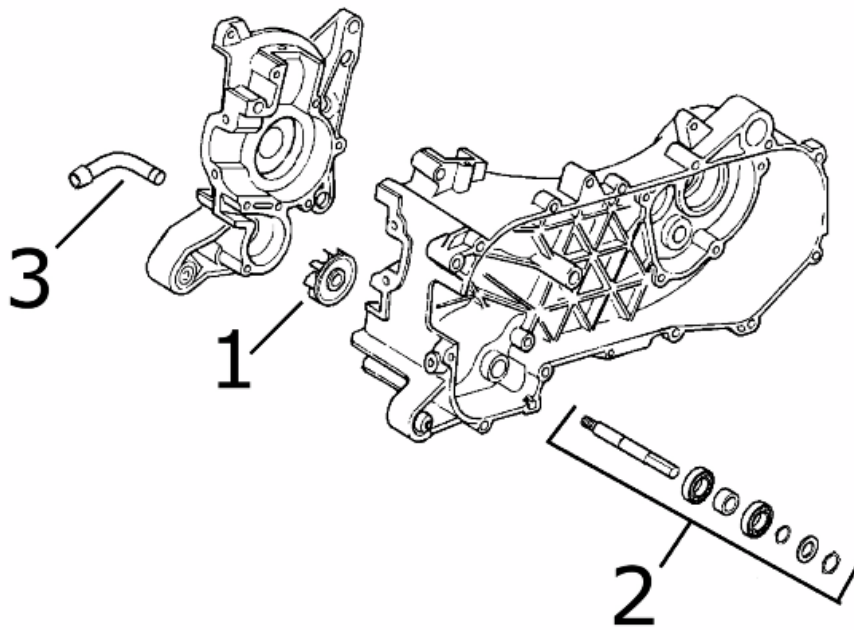

WATER PUMP

	Code	Action	Duration
1	001113	Water pump - Replacement	
2	001062	Water pump command shaft - Replacement	
3	007019	Connection water pump pipe / return pipe - Replacement	

Starter motor

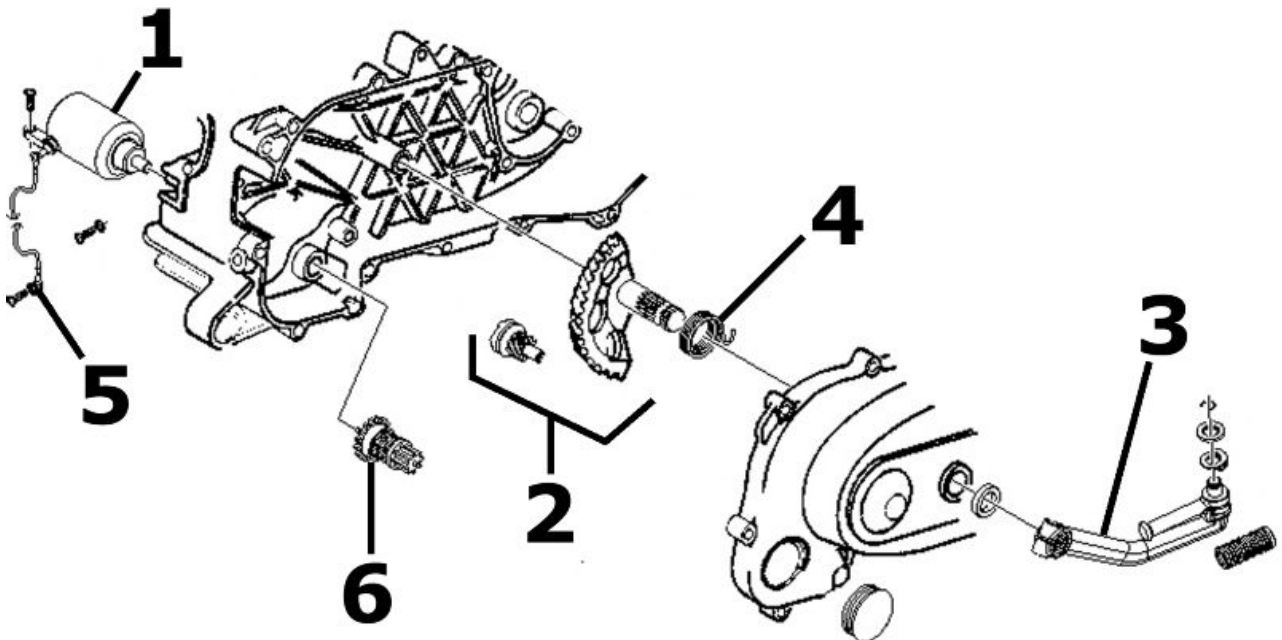

MOTORINO AVVIAMENTO E KICK STARTER

	Code	Action	Duration
1	001020	Starter motor - Replacement	
2	001021	Kick starter - Inspection	
3	001084	Starter lever - Replacement	
4	008008	Starter spring pack - Replacement	
5	005045	Starter motor cable harness - Replacement	
6	001017	Start-up pinion - Replacement	

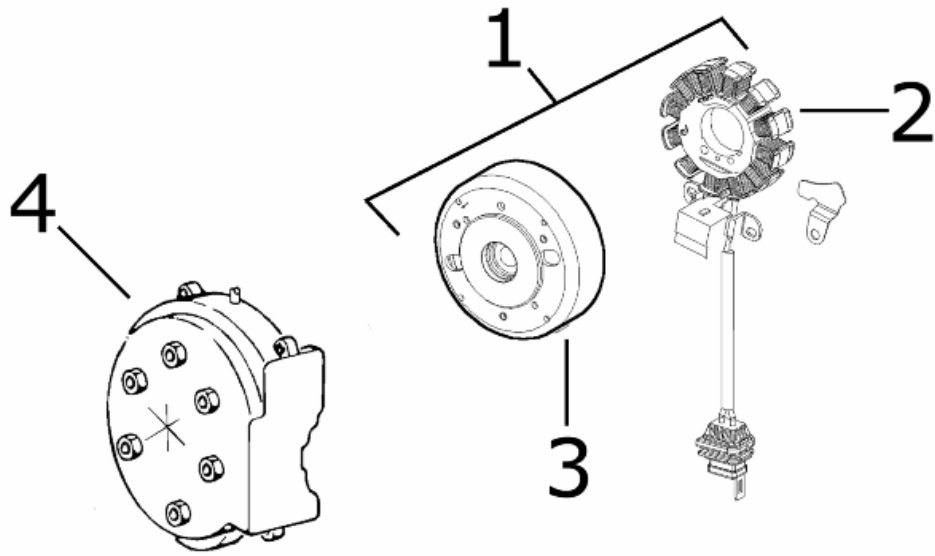
Flywheel magneto**FLYWHEEL MAGNETO**

	Code	Action	Duration
1	001058	Flywheel - Replacement	
2	001067	Stator - Replacement	
3	001173	Rotor - Replacement	
4	001087	Flywheel cover - Replacement	

Carburettor

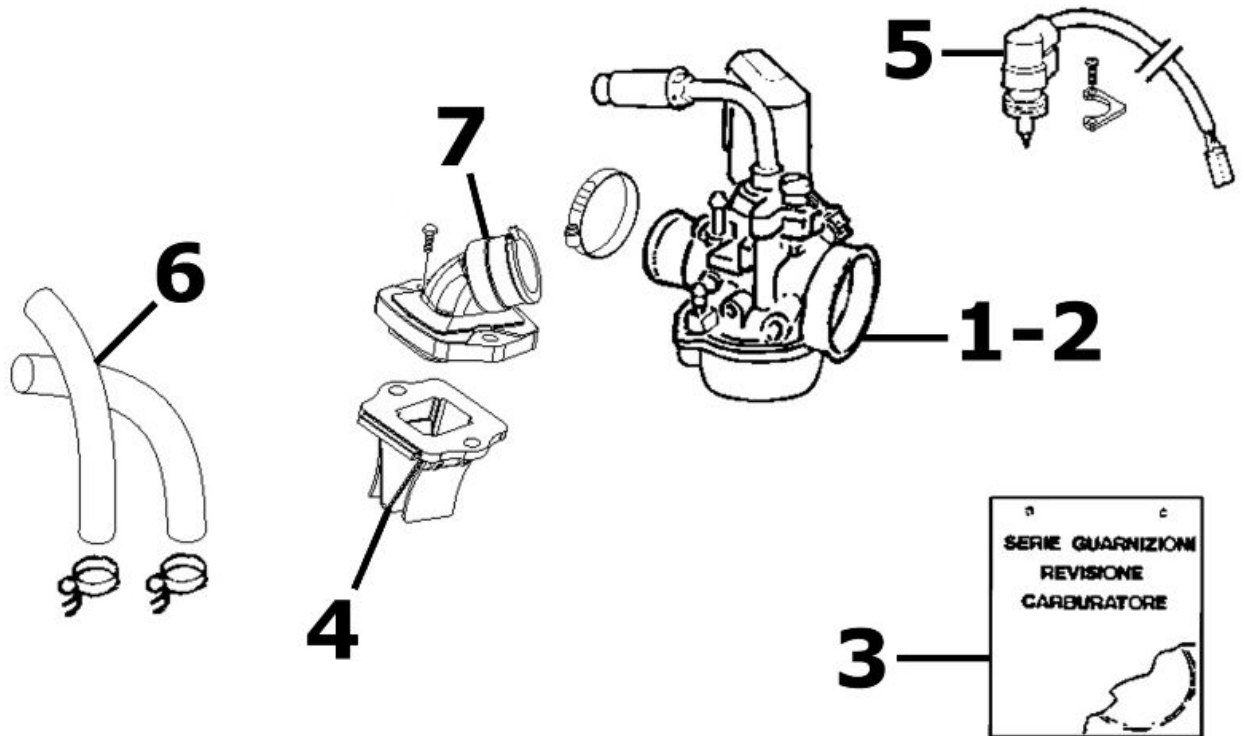

CARBURATORE

	Code	Action	Duration
1	001063	Carburettor - Replacement	
2	003058	Carburettor - Adjustment	
3	001008	Carburettor - Inspection	
4	001178	Disc pack - Replacement	
5	001081	Automatic choke - Replacement	
6	007020	Carburettor heating tubing - replacement	
7	001013	Intake manifold - Replacement	

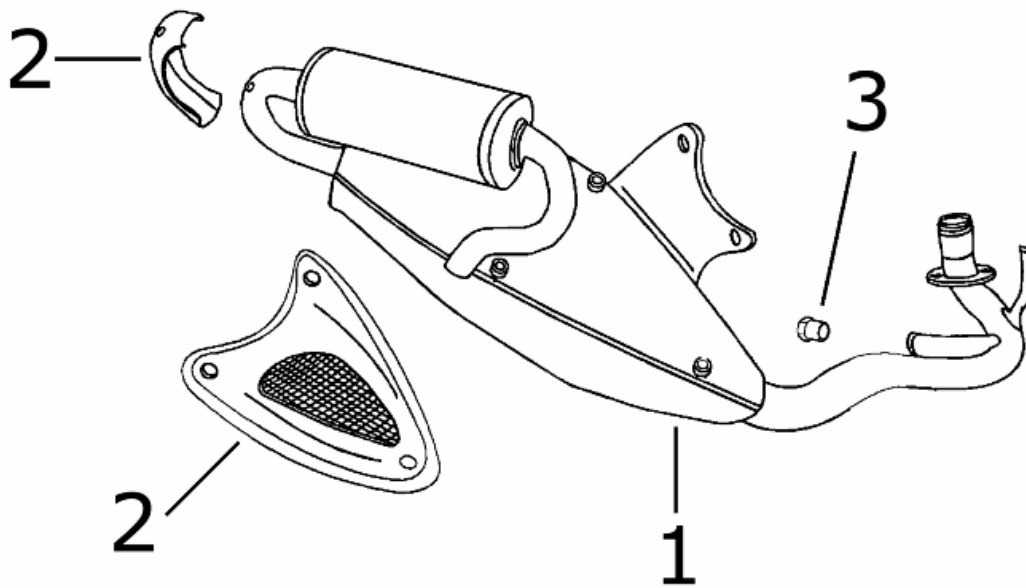
Exhaust pipe**MUFFLER**

	Code	Action	Duration
1	001009	Muffler - Replacement	
2	001095	Muffler guard - Replacement	
3	001136	Exhaust emissions - Adjustment	

Air cleaner

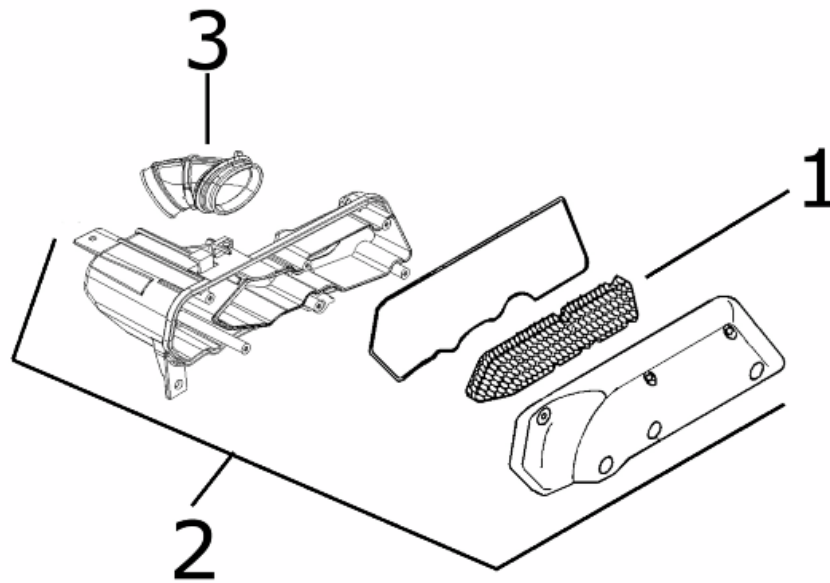

AIR FILTER

	Code	Action	Duration
1	001014	Air filter - Replacement / cleaning	
2	001015	Air filter box - Replacement	
3	004122	Air cleaner carburettor fitting - Replacement	

Frame

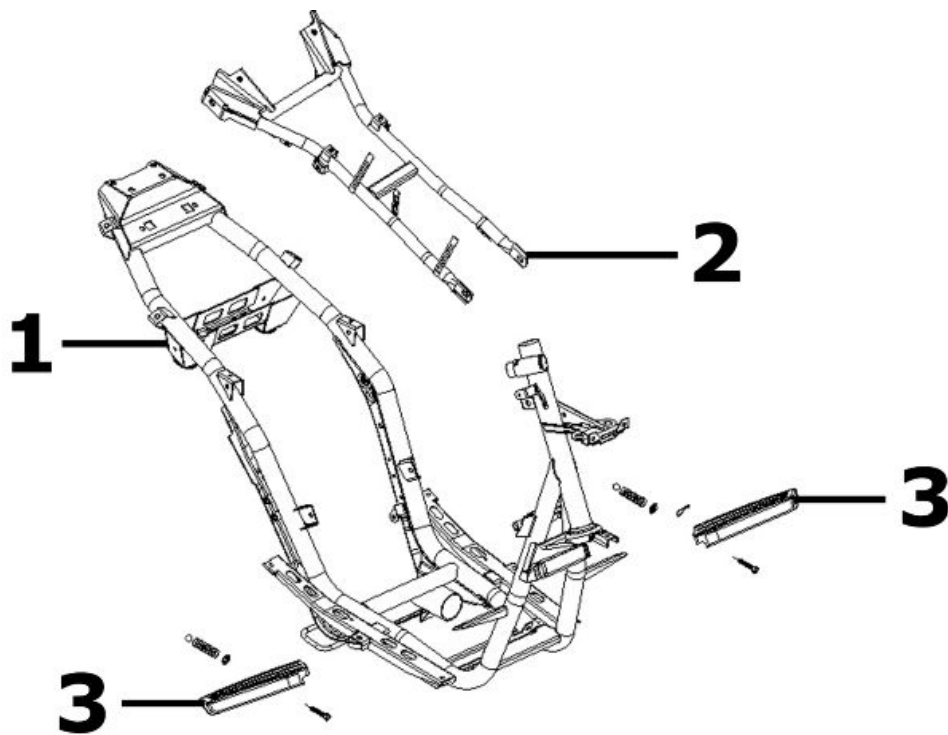
**CHASSIS**

	Code	Action	Duration
1	004001	Frame - replace	
2	004116	Rear frame - Replacement	
3	004015	Footrest - Replacement	

Centre-stand

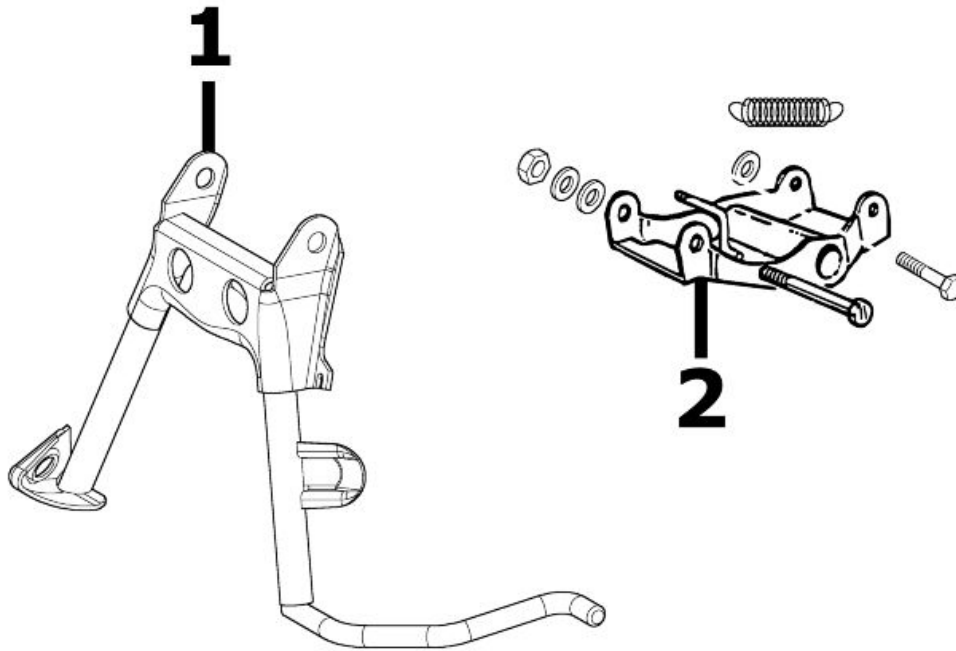

STAND

	Code	Action	Duration
1	004004	Stand - Replacement	
2	004171	Stand support plate - Replacement	

Legshield spoiler

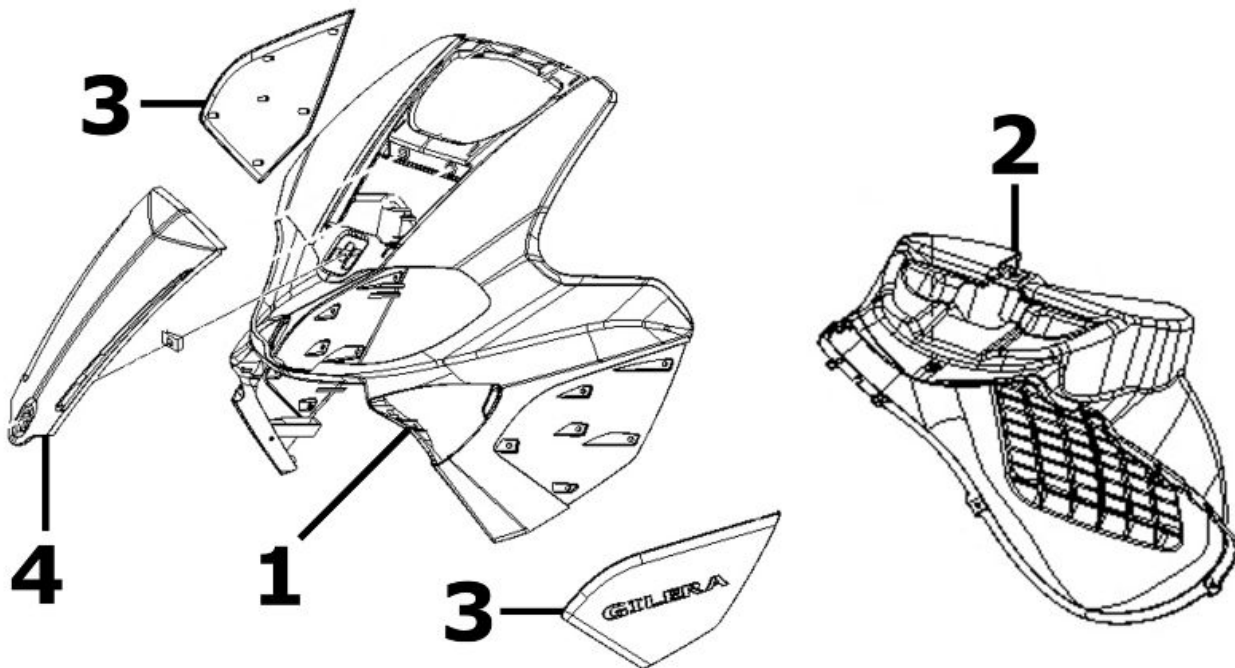
**FRONT SHIELD**

	Code	Action	Duration
1	004064	Front shield - Replacement	
2	004053	Spoiler - Replacement	
3	004182	Side cover - Replacement	
4	004149	Shield central cover - Replacement	

Side fairings

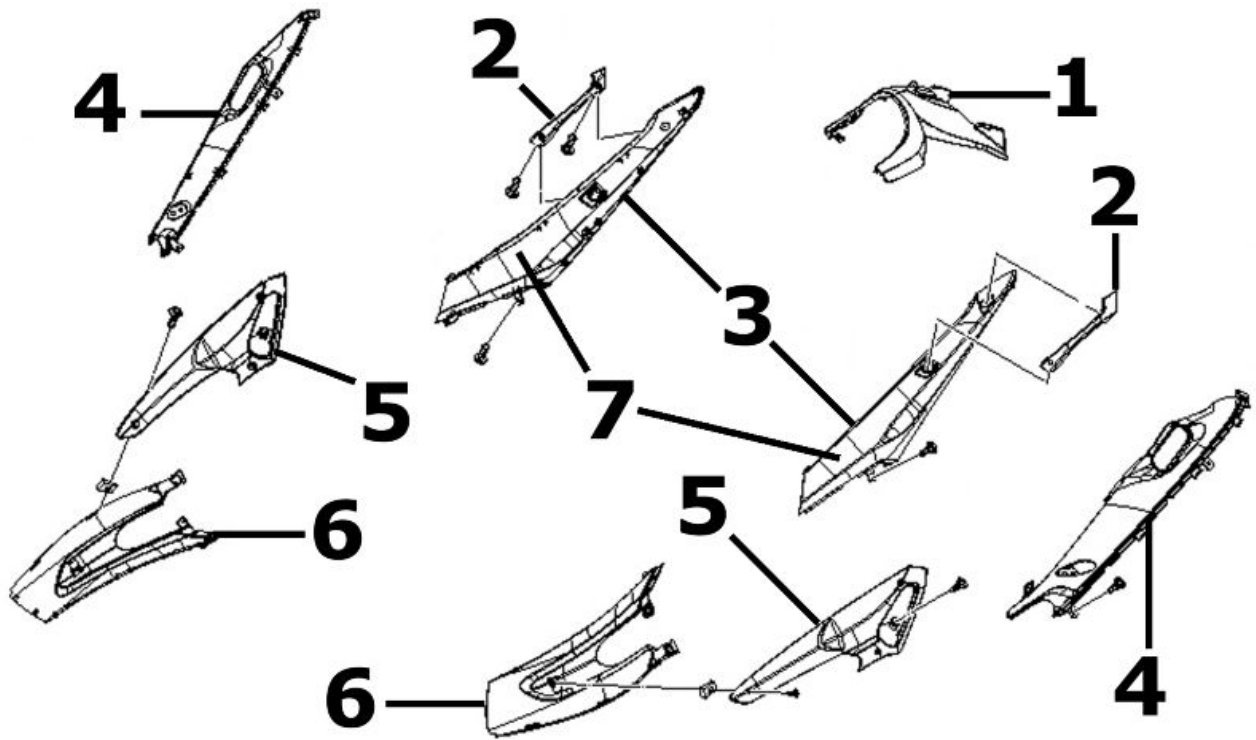

SIDE COVERS

	Code	Action	Duration
1	004057	Taillight lower cover - Replacement	
2	004068	Passenger handgrip - Replacement	
3	004012	Rear fairings - Removal and refitting	
4	004129	Rear fairing - Replacement	
5	004085	Fairing (1) - Replacement	
6	004036	Lower chassis cover - Replacement	
7	004159	Plates / Stickers - Replacement	

Underseat compartment

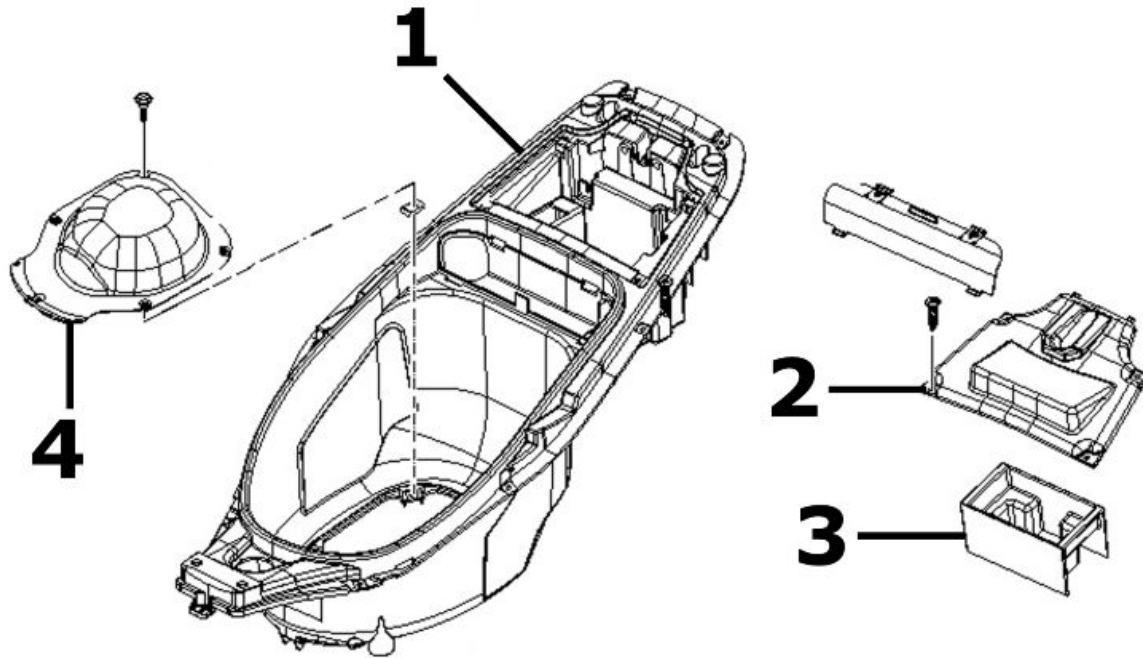

VANO PORTACASCO

	Code	Action	Duration
1	004016	Helmet compartment - Replacement	
2	005046	Battery cover - Replacement	
3	004071	Battery compartment - replacement	
4	004059	Spark plug inspection flap - Replacement	

Mudguard

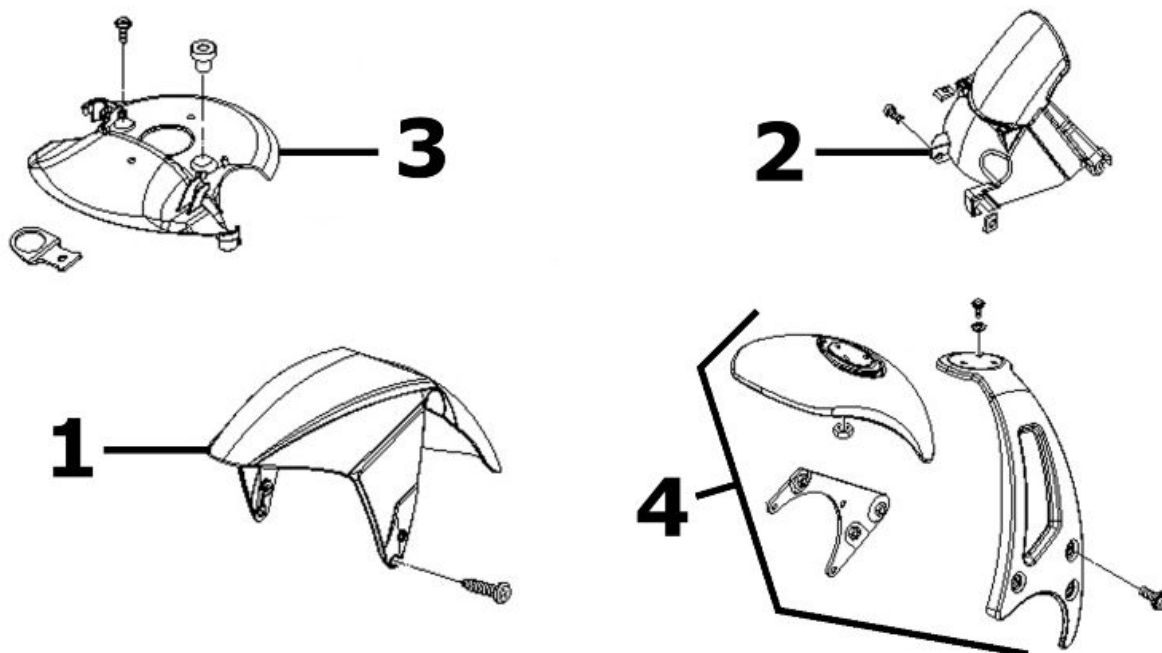

PARAFANGHI

	Code	Action	Duration
1	004002	Front mudguard - Replacement	
2	004009	Rear mudguard - Replacement	
3	003044	Shock absorber cover - Replacement	
4	004052	Bumper - Replacement	

Fuel tank

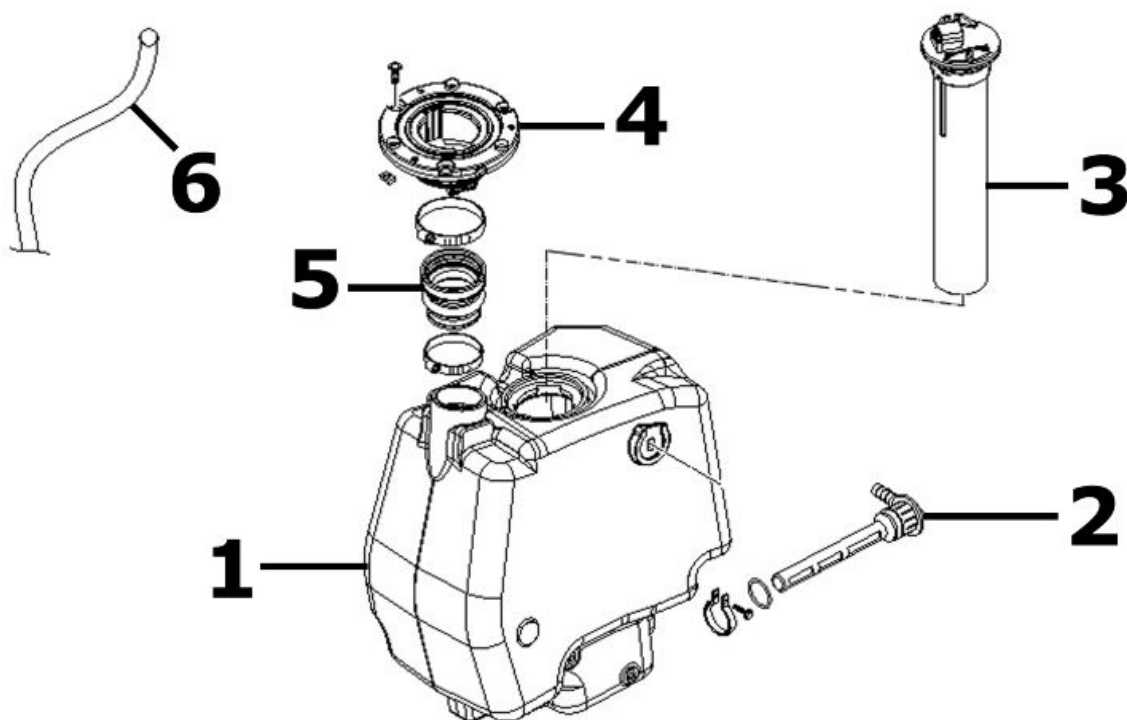
**SERBATOIO CARBURANTE**

	Code	Action	Duration
1	004005	Fuel tank - Replacement	
2	004007	Fuel valve - Replacement	
3	005010	Tank float - Replacement	
4	004170	Tank filler neck - Replacement	
5	004110	Fuel tank hose - Replacement	
6	004109	Fuel tank breather - Replacement	

Tank oil

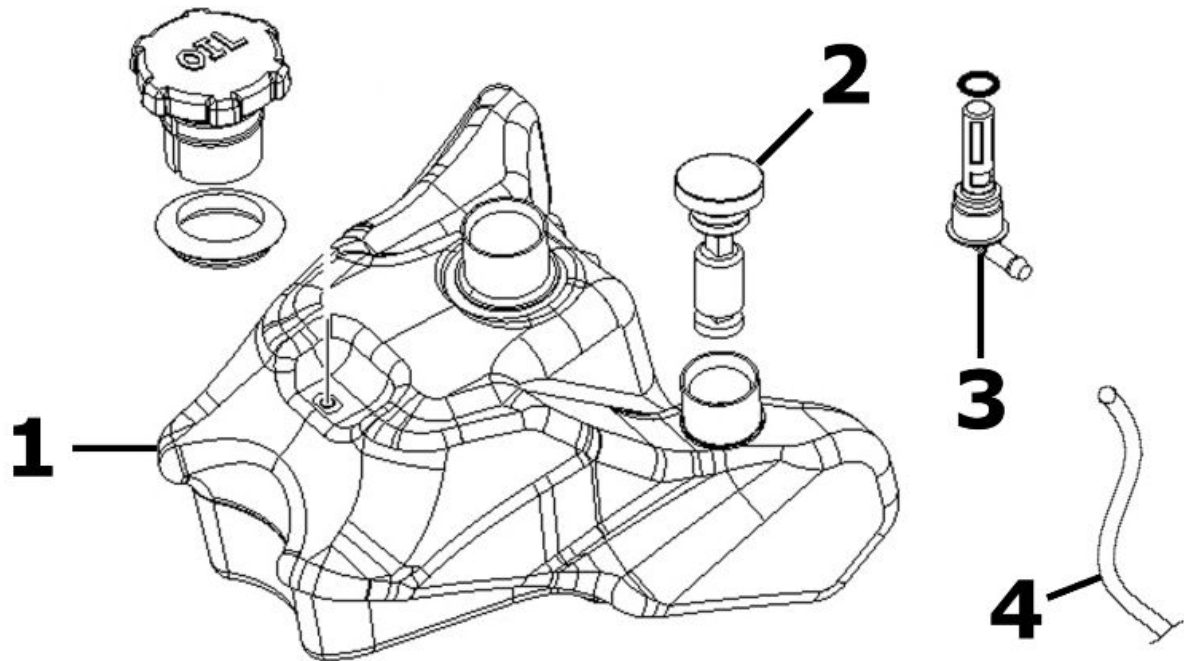

OIL TANK

	Code	Action	Duration
1	004017	Oil reservoir - Replacement	
2	005018	Oil reservoir float - Replacement	
3	004095	Oil reservoir cock - Replacement	
4	004091	Oil reservoir hose - Replacement	

Rear shock-absorber

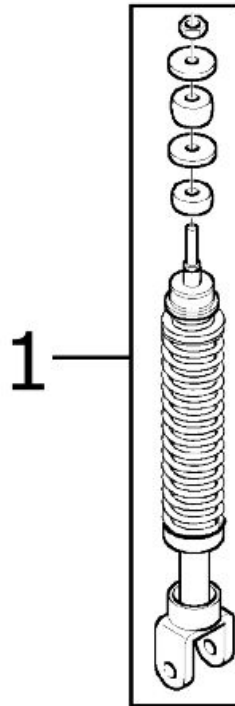

REAR SHOCK ABSORBER

	Code	Action	Duration
1	003007	Rear shock absorbers - Replacement	

Steering column bearings

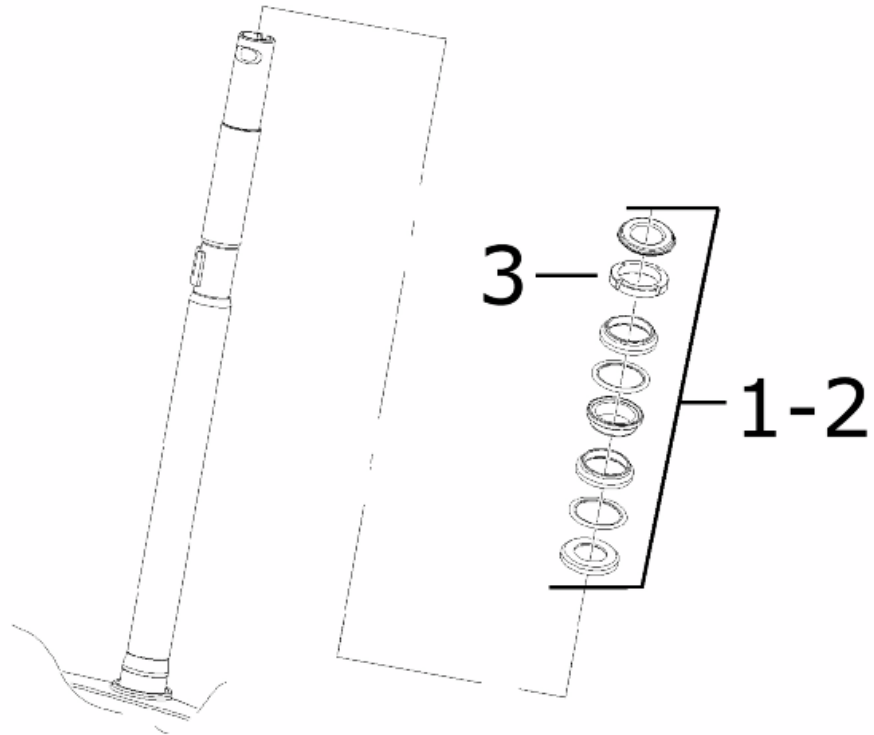

STEERING FIFTH WHEELS

	Code	Action	Duration
1	003002	Steering fifth wheel - Replacement	
2	003073	Steering clearance - Adjustment	
3	004119	Bearing / upper steering fifth wheel - Replacement	

Handlebar components

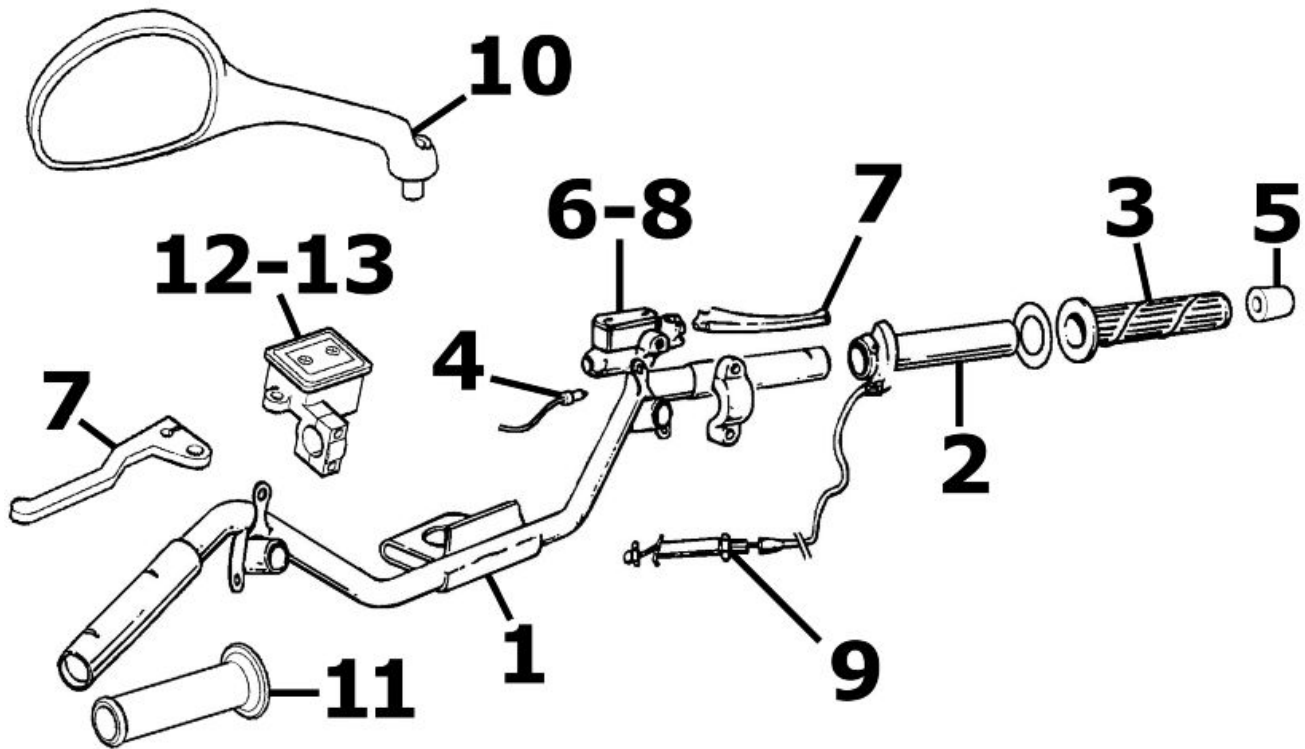

HANDLEBAR COMPONENTS

	Code	Action	Duration
1	003001	Handlebar - Replacement	
2	002060	Complete throttle control - Replacement	
3	002059	Right hand grip - Replacement	
4	005017	Stop switch - Replacement	
5	003059	Counterweight - Replacement	
6	002024	Front brake pump - replace	
7	002037	Brake or clutch lever - Replacement	
8	002047	Front brake fluid and air bleeding system - Replacement	
9	003061	Accelerator transmission - Adjustment	
10	004066	Driving mirror - Replacement	
11	002071	Left hand grip - Replacement	
12	002067	Rear brake pump - Replacement	
13	002080	Rear brake oil bleeding system - Replacement	

Swing-arm

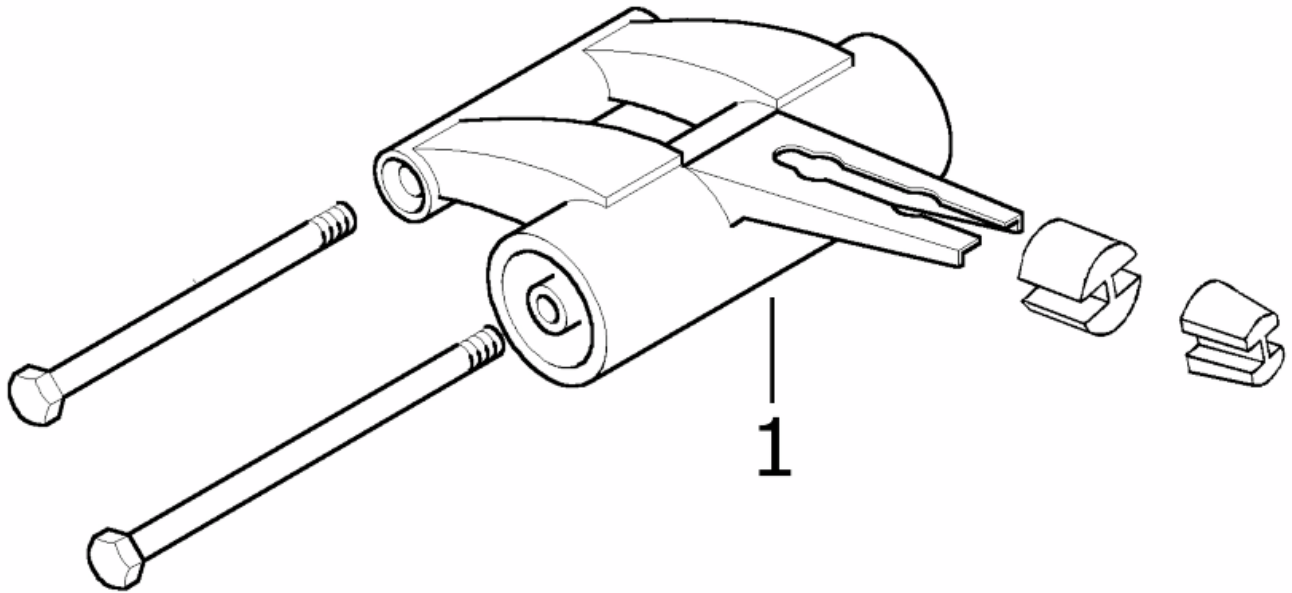

SWINGING ARM

	Code	Action	Duration
1	001072	Engine / frame swinging arm fitting - Replacement	

Seat

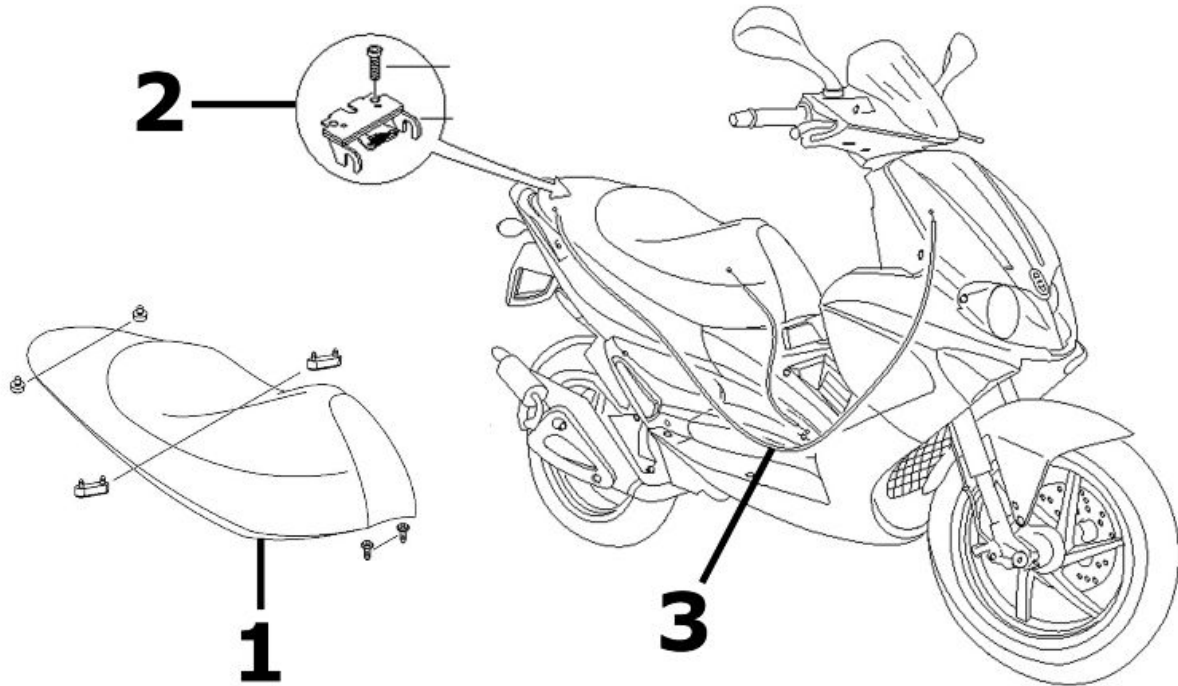
**SELLA**

	Code	Action	Duration
1	004003	Saddle - Replacement	
2	004054	Seat lock hook - Replacement	
3	002083	Saddle opening transmission - Replacement	

Instrument panel

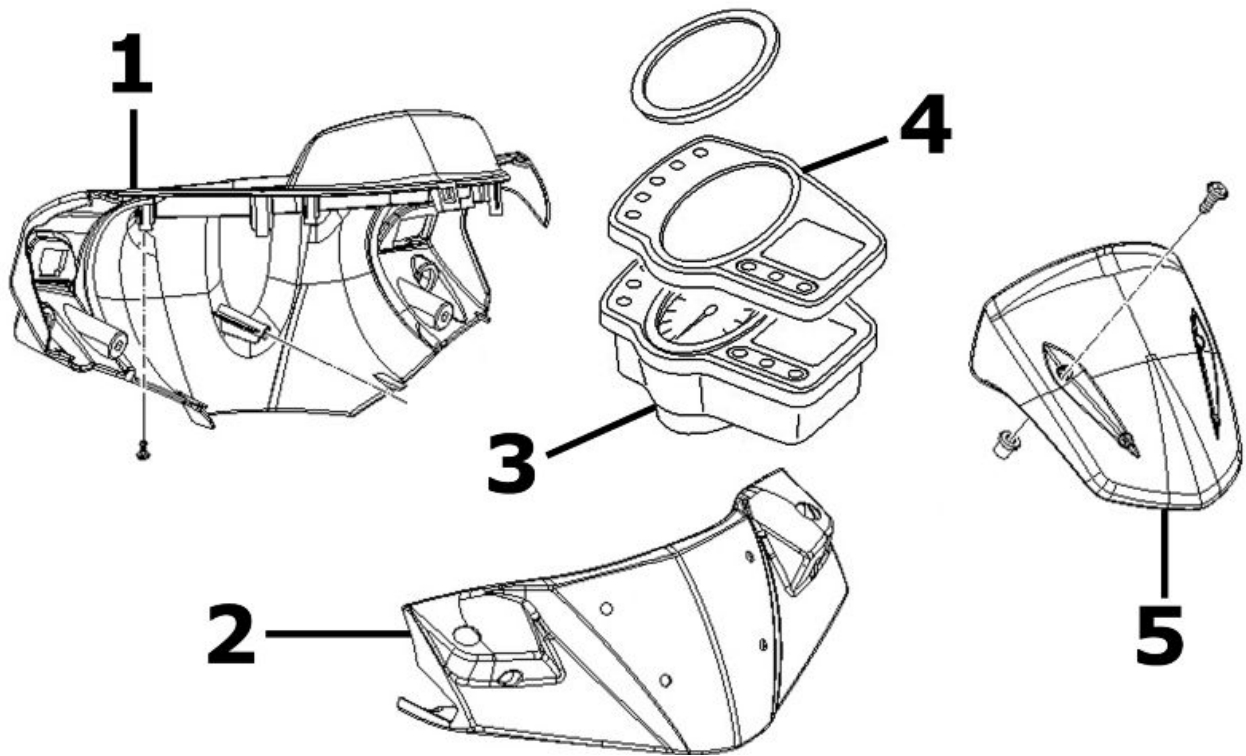

GRUPPO STRUMENTI E COPRIMANUBRIO

	Code	Action	Duration
1	004019	Handlebar rear section - Replacement	
2	004018	Handlebar front section - Replacement	
3	005014	Odometer - Replacement	
4	005078	Odometer glass - Replacement	
5	004117	Top fairing - Replacement	

Turn signal lights

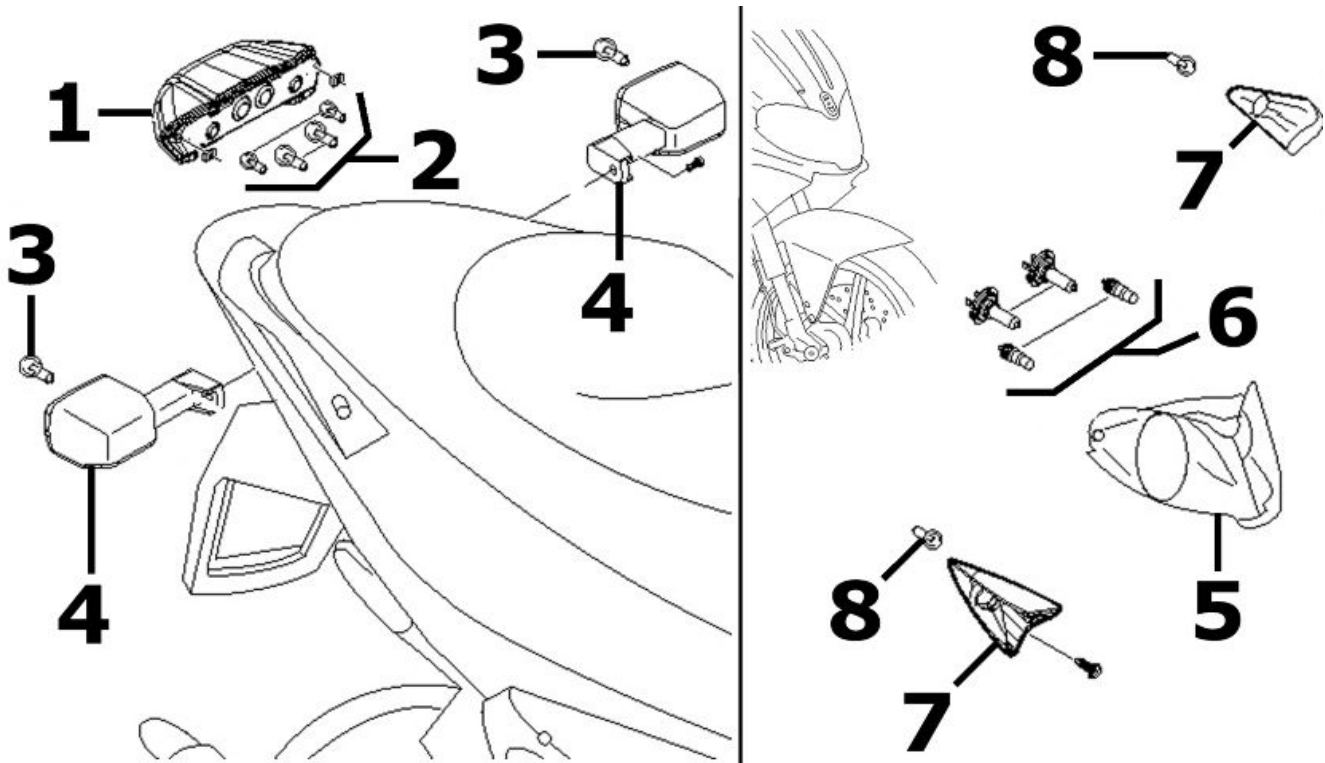
**FANALE ANTERIORE**

	Code	Action	Duration
1	005005	Taillight - Replacement	
2	005066	Rear light bulbs - Replacement	
3	005068	Rear turn indicator bulb - Replacement	
4	005022	Rear turn indicators - Replacement	
5	005002	Front headlamp - Replacement	
6	005008	Front headlamp bulbs - Replacement	
7	005012	Front turn indicator - Replacement	
8	005067	Front turn indicator bulb - Replacement	

Front wheel

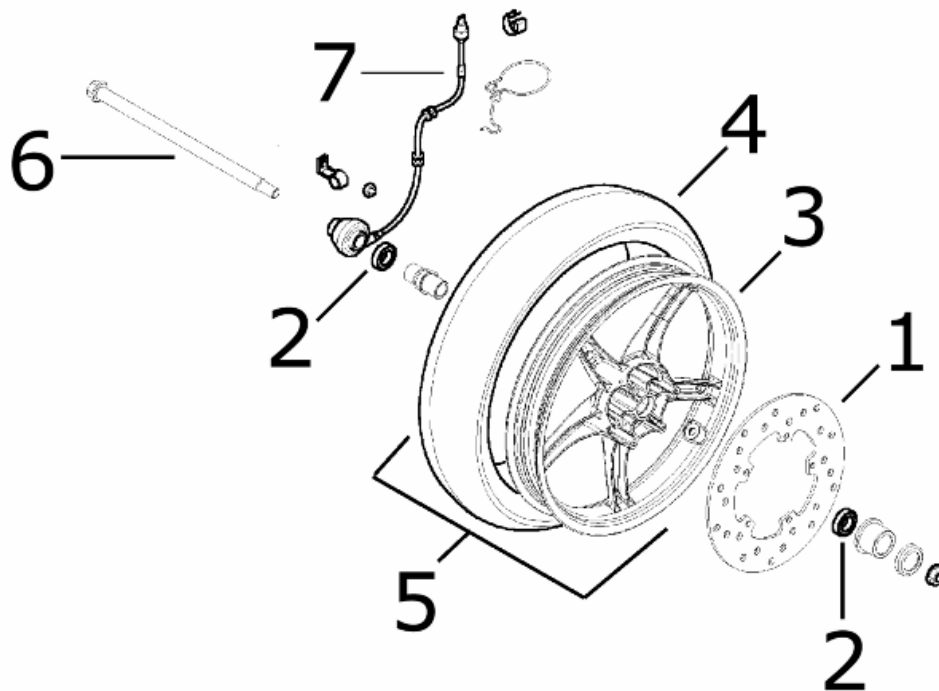

FRONT WHEEL

	Code	Action	Duration
1	002041	Front brake disc - Replacement	
2	003040	Front wheel bearings - Replacement	
3	003037	Front wheel rim- Replacement	
4	003047	Front tyre - replace	
5	004123	Front wheel - Replacement	
6	003038	Front wheel axle - Replacement	
7	005089	Tone wheel - Replacement	

Grease tone wheel or drive

Please take note that the code has been introduced:

900001 - Tone wheel / drive greasing - 15'.

Never mistake the codes 002011 (movement sensor replacement) and 005089 (tone wheel replacement) in the event of noise of the indicated components. The grease recommended is TUTE-LA MRM 2 (soap-based lithium grease with Molybdenum disulphide).

In the following points we indicate with an arrow the area to be greased (1 - Drive, 2 - Tone wheel)

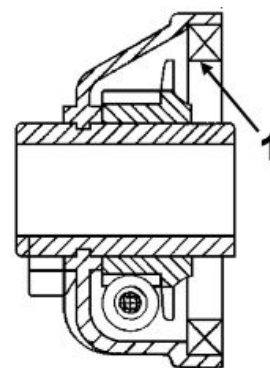

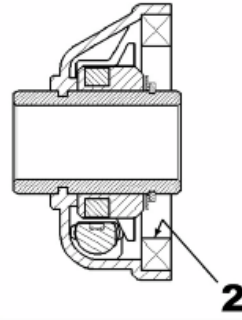

Rear wheel

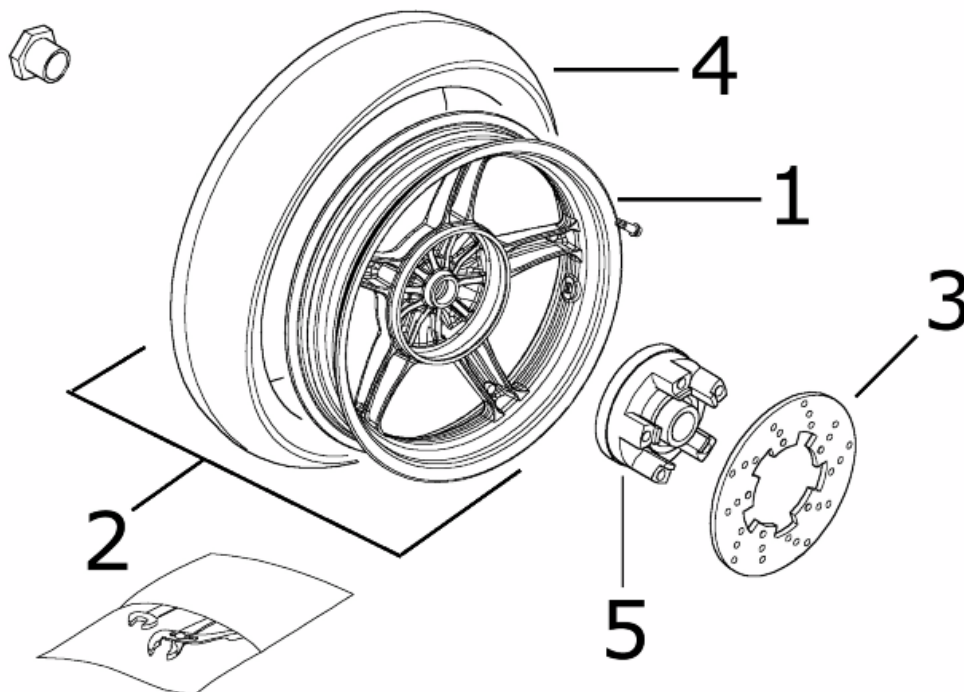

REAR WHEEL

	Code	Action	Duration
1	001071	Rear wheel rim - Replacement	
2	001016	Rear wheel - Replacement	
3	002070	Rear brake disc - Replacement	
4	004126	Rear wheel tyre - Replacement	
5	002028	Rear wheel hub - Replacement	

Fuel pump

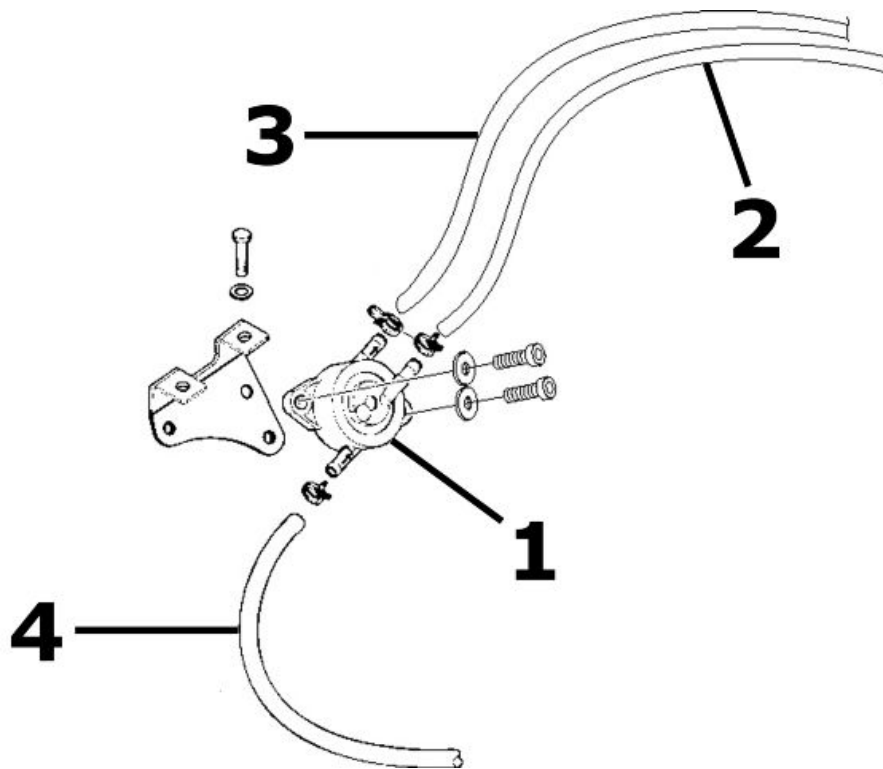

POMPA CARBURANTE

	Code	Action	Duration
1	004073	Fuel pump - Replacement	
2	004137	Pump / carburettor hose - Replacement	
3	004086	Petrol pump depression tube - Replacement	
4	004089	Tank / petrol pump pipe - Replacement	

Electric devices

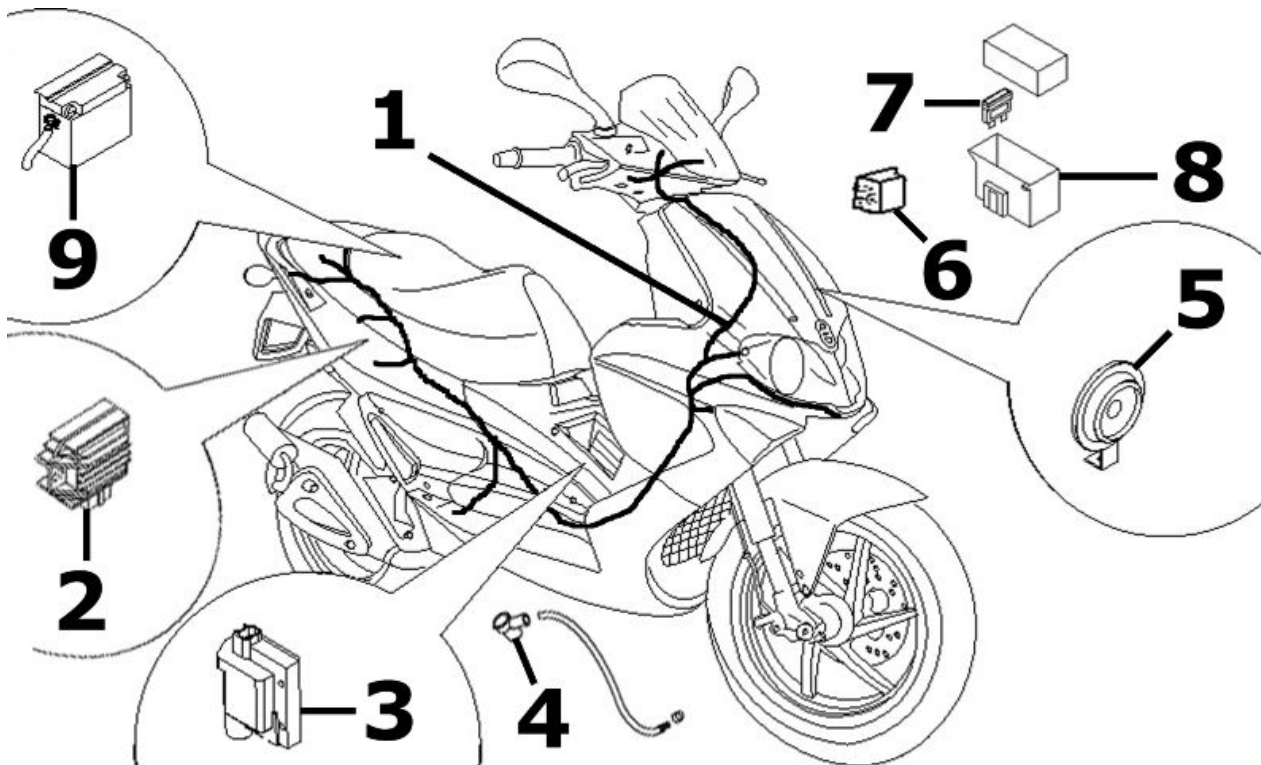
**IMPIANTO ELETTRICO**

	Code	Action	Duration
1	005001	Electrical system - Replacement	
2	005009	Voltage regulator - Replacement	
3	001023	Control unit - Replacement	
4	001094	Spark plug cap - Replacement	
5	005003	Horn - Replacement	
6	005011	Start-up remote control switch - Replacement	
7	005052	Fuse (1) - Replacement	
8	005054	Fuse block (1) - Replacement	
9	005007	Battery - Replacement	

Electronic controls

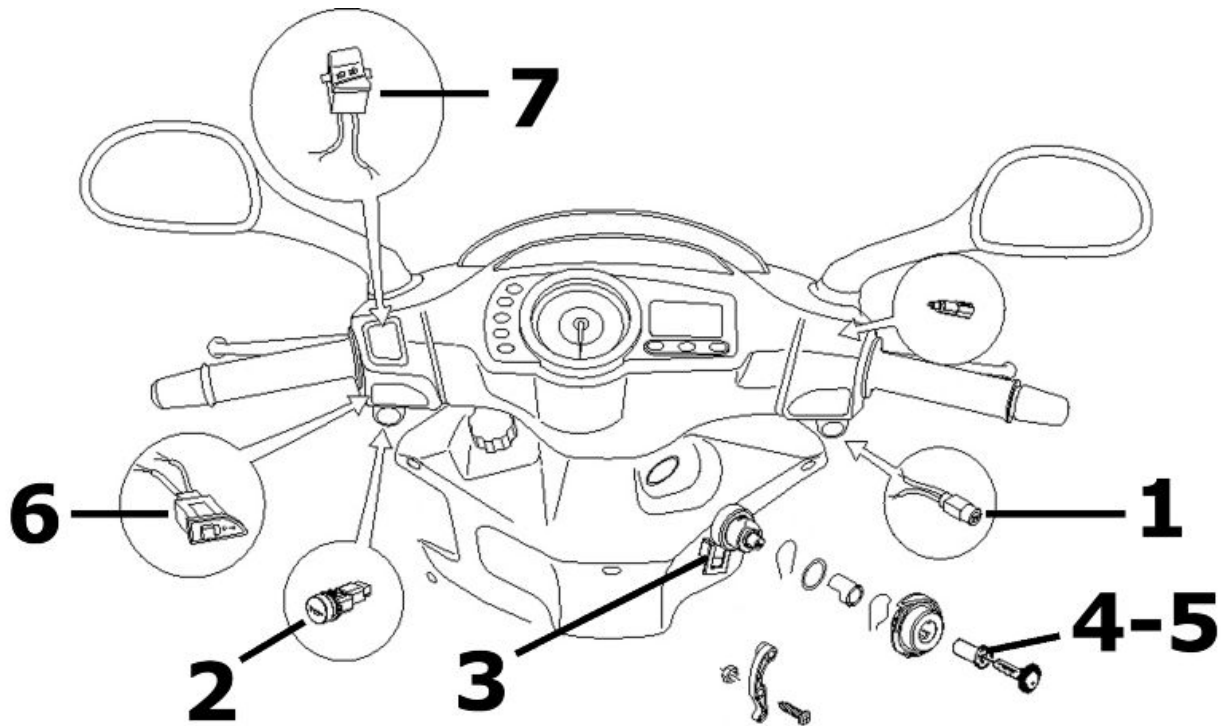

COMANDI ELETTRICI

	Code	Action	Duration
1	005041	Starter button - Replacement	
2	005040	Horn button - Replacement	
3	005016	Key switch - Replacement	
4	004096	Lock series - Replacement	
5	004010	Antitheft lock - replace	
6	005006	Light switch or turn indicators - Replacement	
7	005039	Headlight switch - Replacement	

Brake callipers

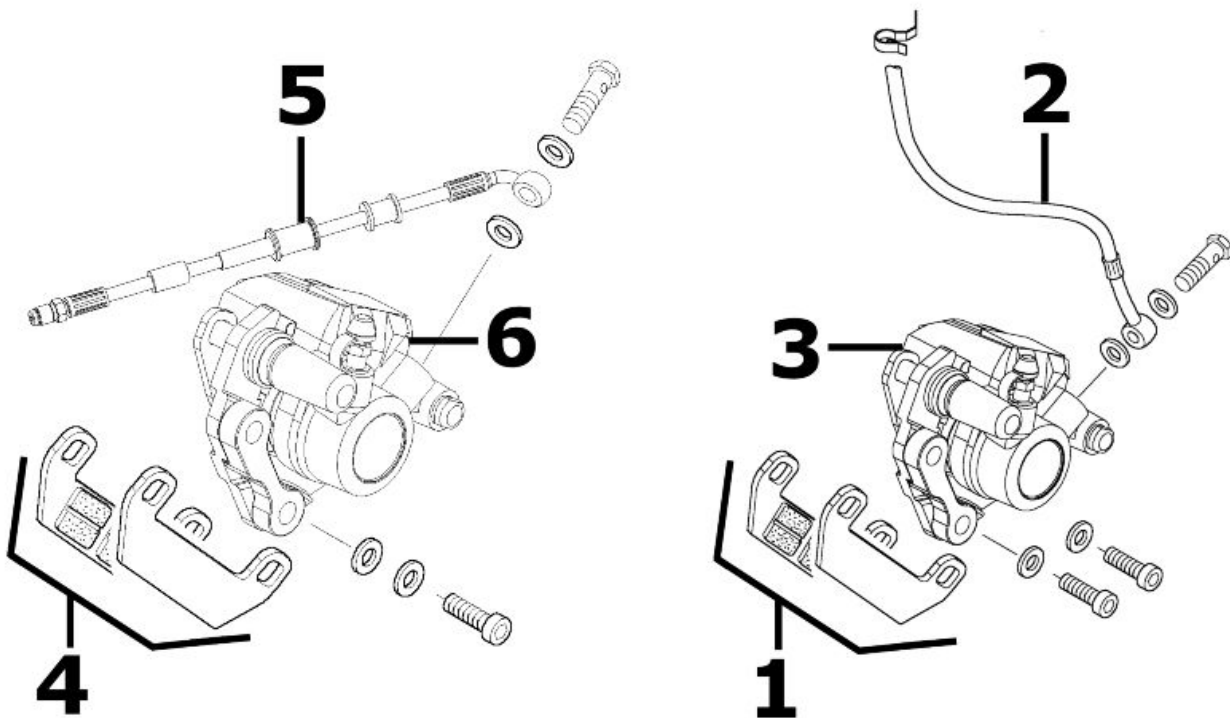

BRAKE CALLIPERS

	Code	Action	Duration
1	002007	Front brake pads - Replacement	
2	002021	Front brake piping - Replacement	
3	002039	Front brake calliper - Replacement	
4	002002	Rear brake pads - Replacement	
5	002020	Rear brake disc piping - Replacement	
6	002048	Rear brake calliper - Replacement	

Rear side fairings

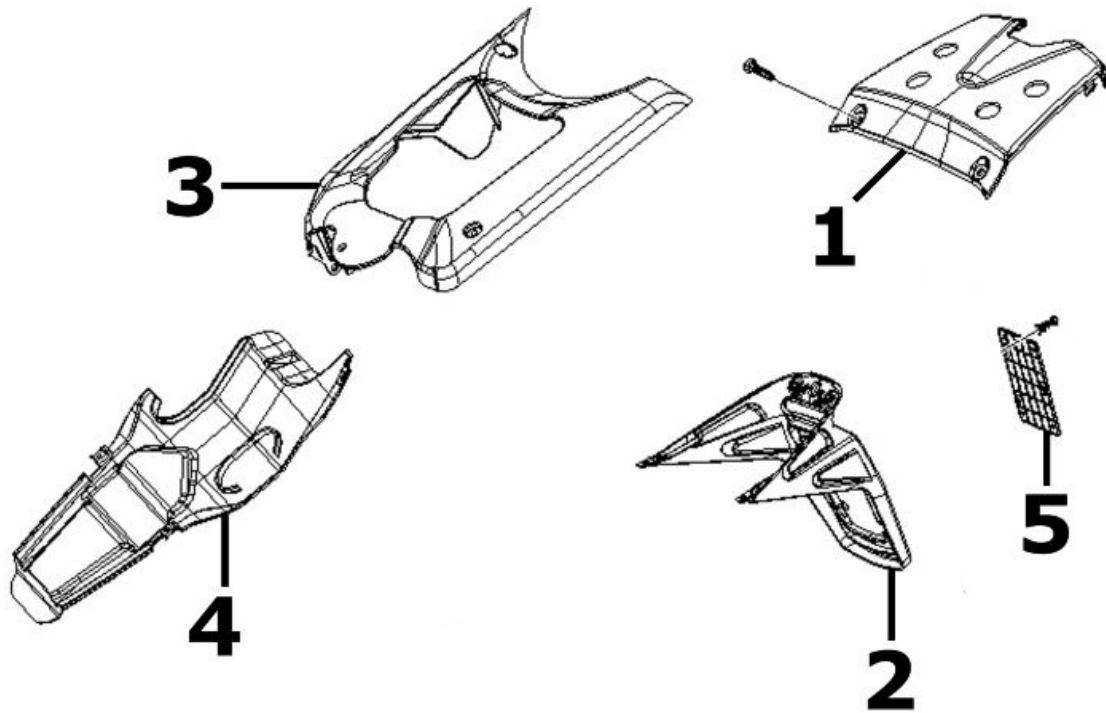

REAR COVERS

	Code	Action	Duration
1	004056	Upper rear light cover - Replacement	
2	004136	License plate support - Replacement	
3	004183	Cover for engine components - Replacement	
4	004181	Lower cover - Replacement	
5	005048	Licence plate holder - Replacement	

Front suspension

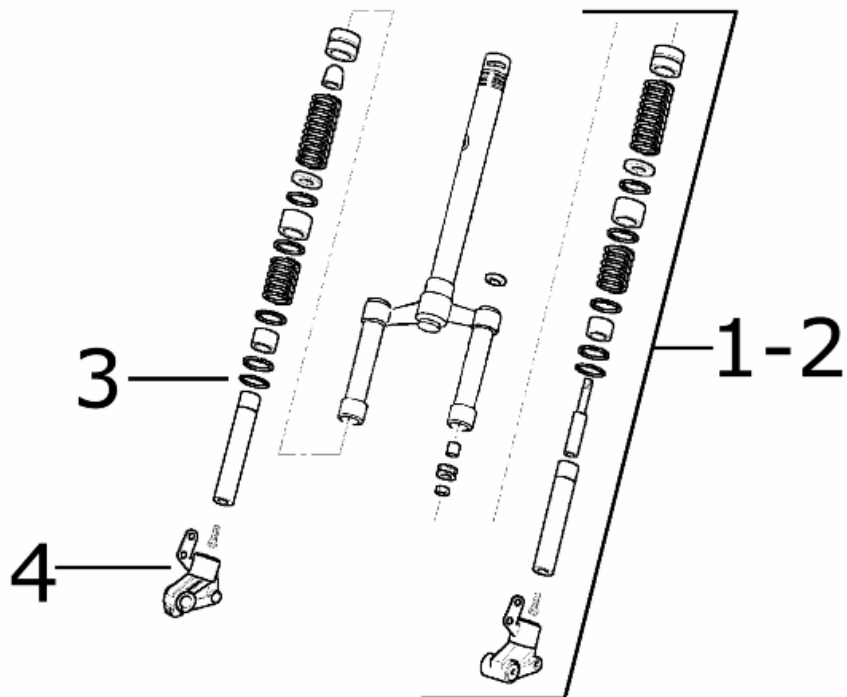

FORK

	Code	Action	Duration
1	003010	Front suspension - Service	
2	003051	Complete fork - replace	
3	003048	Fork oil seal - Replacement	
4	003041	Fork stanchion - Replacement	

Cooling system

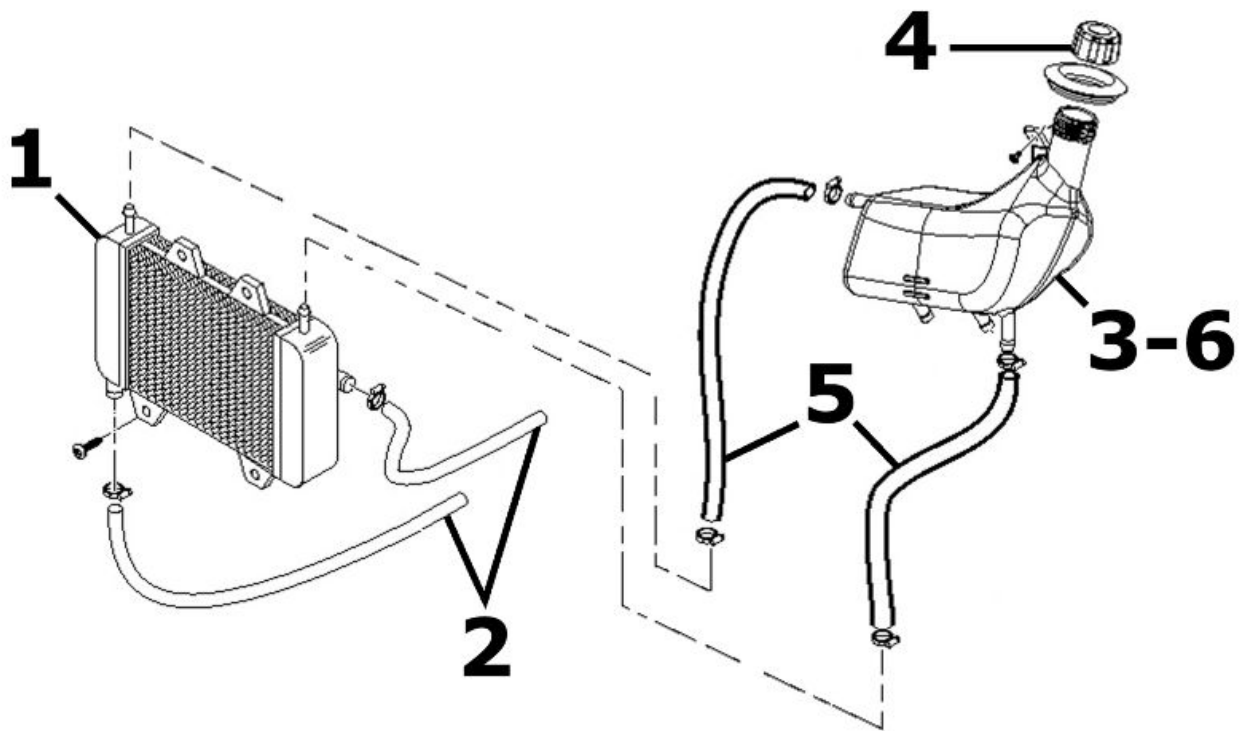

IMPIANTO DI RAFFREDDAMENTO

	Code	Action	Duration
1	007002	Water cooling radiator - Replacement	
2	007003	Delivery line and coolant return - Replacement	
3	007001	Expansion tank - Replacement	
4	007024	Expansion tank cap - Replacement	
5	007013	Expansion tank / radiator connecting hose - Replacement	
6	001052	Coolant and air bleed - Replacement	

Secondary air box

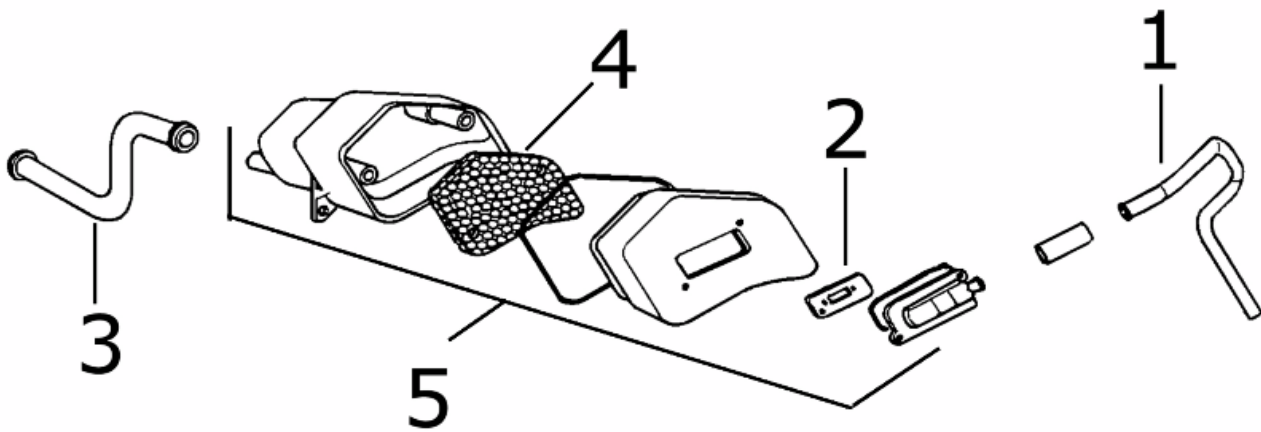

SECONDARY AIR SYSTEM

	Code	Action	Duration
1	001163	Muffler secondary air connection - Replacement	
2	001165	Secondary air reed - Replacement	
3	001164	Crankcase secondary air connection - Replacement	
4	001161	Secondary air filter - Replacement / Cleaning	
5	001162	Secondary air housing - Replacement	

A

Air filter: 32, 131

B

Battery: 41, 48, 57, 135

Brake: 102, 110, 112–114, 116, 178

C

Carburettor: 10, 155

E

Engine stop:

F

Fuel: 39, 97, 133, 134, 164, 175

Fuses: 56

H

Headlight: 36, 125

Hub oil: 30

I

Identification: 8

Instrument panel: 50, 171

M

Maintenance: 7, 27

S

Shock absorbers: 107

Spark plug: 30

Stand:

T

Tank: 133, 134, 164, 165

Transmission: 9, 40, 67, 151

Tyres: 10