



E-TON POWER

EV3 E-MO



SERVICE MANUAL

E-MO
SERVICE MANUAL
2009 by E-TON POWER TECH CO., LTD.
First edition, April 2009
All rights reserved.
Any reproduction or unauthorized use
without the written permission of
E-TON POWER TECH CO., LTD.
is expressly prohibited.

IMPORTANT

This manual was produced by the E-TON POWER TECH CO., LTD., primarily for use by E-TON dealers and their qualified mechanics. It is not possible to include all the knowledge of a mechanic in one manual. Therefore, anyone who uses this book to perform maintenance and repairs on E-TON vehicles should have a basic understanding of the mechanics and the techniques to repair these types of vehicles. Repair and maintenance work attempted by anyone without this knowledge is likely to render the vehicle unsafe and unfit for use.





E-TON POWER TECH CO., LTD., is continually striving to improve all of its models. Modifications and significant changes in specifications or procedures will be forwarded to all authorized E-TON dealers and will appear in future editions of this manual where applicable.

NOTE: _____

Designs and specifications are subject to change without notice.

IMPORTANT INFORMATION

Particularly important information is distinguished in this manual by the following notations:

	This is the safety alert symbol. It is used to alert you to potential personal injury hazards. Obey all safety messages that follow this symbol to avoid possible injury or death.
	A WARNING indicates a hazardous situation which, if not avoided, could result in death or serious injury.
	A NOTICE indicates special precautions that must be taken to avoid damage to the vehicle or other property.
	A TIP provides key information to make procedures easier or clearer.

* Product and specifications are subject to change without notice.

TABLE OF CONTENTS

GENERAL INFORMATION

**GEN
INFO**



SPECIFICATIONS

SPEC



**PERIODIC CHECKS AND
ADJUSTMENTS**

**CHK
ADJ**



CONTROLLER SYSTEM

CONT

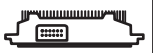

BATTERY/ CHARGER

**BAT
CHA**

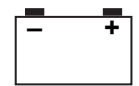

ELECTRICAL SYSTEM

ELEC



CHASSIS

CHAS



TROUBLESHOOTING

**TRBL
SHTG**



CHAPTER 1

GENERAL INFORMATION

GENERAL INFORMATION	1-1
FRAME SERIAL NUMBER	1-1
MOTOR SERIAL NUMBER	1-1
IMPORTANT INFORMATION	1-2
REPLACEMENT PARTS	1-2
GASKETS, OIL SEALS AND O-RINGS	1-2
CHECKING THE CONNECTIONS	1-3
SPECIAL TOOLS	1-4

IDENTIFICATION OF SCOOTER

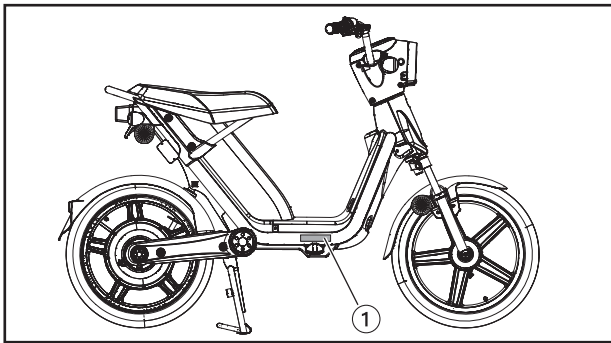

GENERAL INFORMATION SCOOTER IDENTIFICATION

FRAME SERIAL NUMBER

The frame serial number ① is stamped on the chassis.

TIP

The fourth to the sixth digits of these numbers are for identifying the model; the remaining digits constitute the production number of the unit.

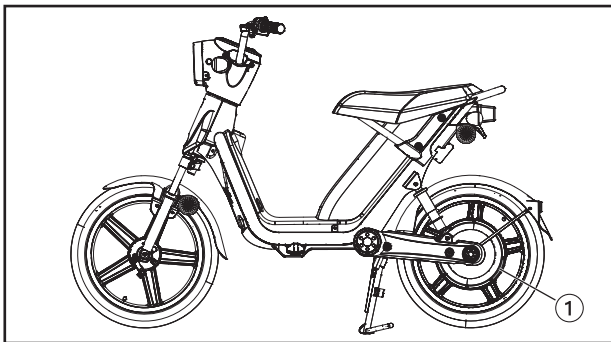

MOTOR SERIAL NUMBER

The serial number of the motor ① is stamped on the portion of the left section of the motor box.

TIP

Designs and specifications are subject to change without notice.

IMPORTANT INFORMATION

REPLACEMENT PARTS

1. Use only genuine E-TON parts for all replacements. Use the oil and/or grease recommended by E-TON for assembly and adjustment.

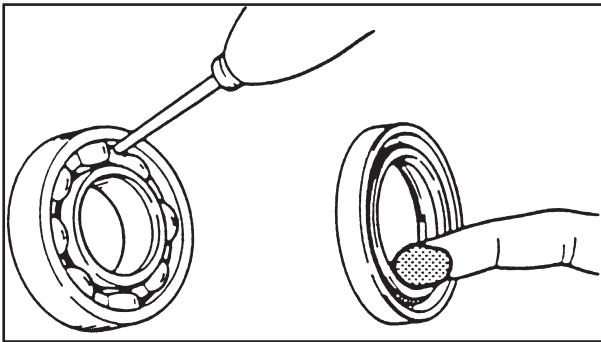

GASKETS, OIL SEALS AND O-RINGS

1. Replace all gaskets, seals and O-rings when overhauling the rim. All gasket surfaces, oil seal lips and O-rings must be cleaned.
2. Properly oil all mating parts and bearings during reassembly. Apply grease to the oil seal lips.

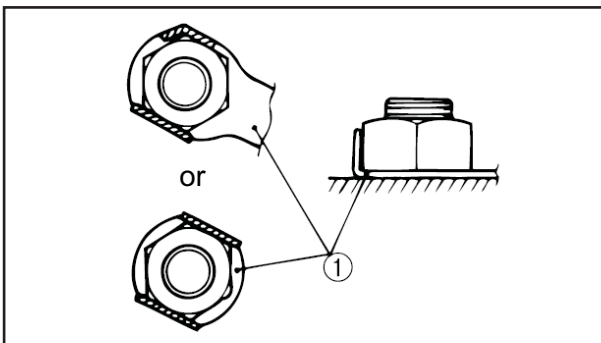

LOCK WASHERS/PLATES AND COTTER PINS

1. Replace all lock washers/plates ① and cotter pins after removal. Bend lock tabs along the bolt or nut flats after the bolt or nut has been tightened to specification.

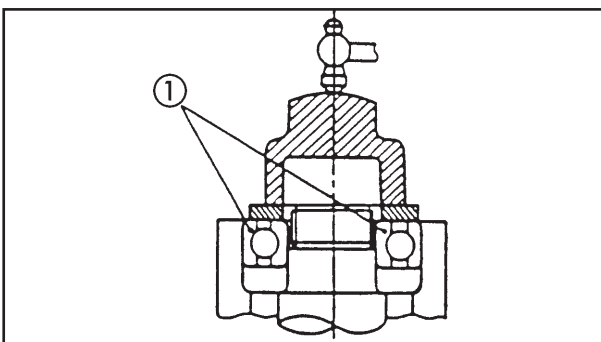

BEARINGS AND OIL SEALS

1. Install the bearings ① and oil seals ② with their manufacturer brands or numbers facing outwards. (In other words, the stamped letters should be on the side exposed to view.) When installing oil seals, apply a light coating of lightweight lithium base grease to the seal lips. Put oil on the bearings when installing.

NOTICE

Do not use compressed air to spin the bearings dry. This will damage the bearing surface.

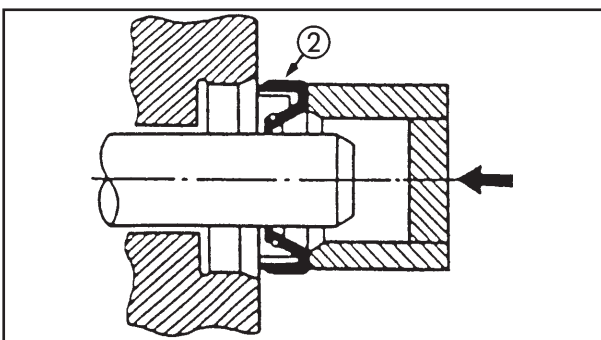

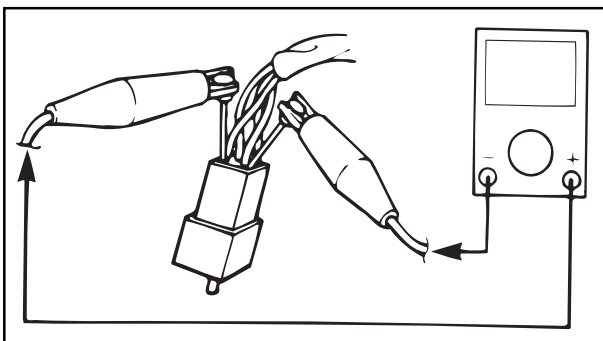
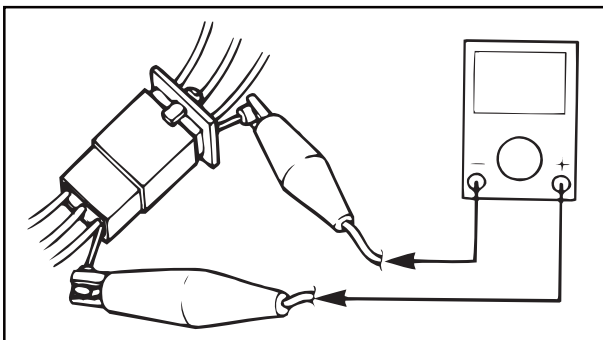
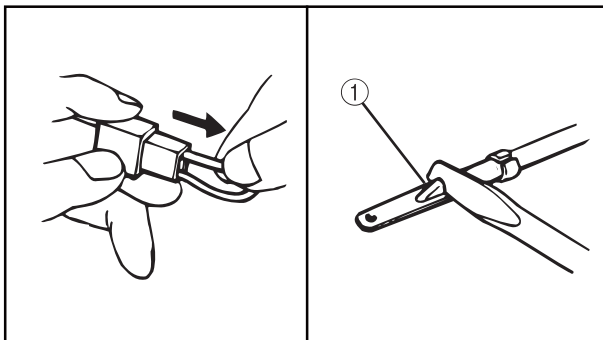
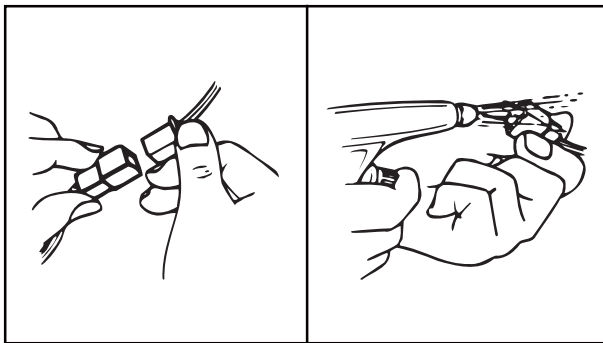

CHECKING THE CONNECTIONS

Check the leads, couplers, and connectors for stains, rust, moisture, etc.

1. Disconnect:

- lead
- coupler
- connector

2. Check:

- lead
- coupler
- connector

Moisture → Dry with an air blower.

Rust/stains → Connect and disconnect several times.

3. Check:

- all connections

Loose connection → Connect properly.

TIP

If the pin ① on the terminal is flattened, bend it up.

4. Connect:

- lead
- coupler
- connector

TIP

Make sure all connections are tight.

5. Check:

- continuity (with the pocket tester)

TIP

- If there is no continuity, clean the terminals.
- When checking the wire harness, perform steps 1 to 3.
- As a quick remedy, use a contact revitalizer available at most part stores.

SPECIAL TOOLS





SPECIAL TOOLS

The following special tools are necessary for complete and accurate tune-up and assembly. Use only the appropriate special tools as this will help prevent damage caused by the use of inappropriate tools or improvised techniques.

Tool NO.	Tool name / Function	Picture
SE3200-5BA0-0FA1	<p>Tool name: Six legs socket</p> <p>Function: To disassemble and assemble the nut of front fork component.</p>	 
SA6100-A26-0FA1	<p>Tool name: Bearing inner puller set</p> <p>Function: To disassemble the bearing of front wheel.</p> <p>Specification: 8, 10, 12, 15, 17, 20, 22, 25, 30, 32/ mm</p>	 
SA6100-A26-0FA2	<p>Tool name: Oil seal & bearing installer set</p> <p>Function: Used for installing the bearing of the front wheel and oil seal.</p> <p>Specification: 27, 32, 35, 40, 42, 45, 47, 48, 52, 58, 64/ mm</p>	 
SD4712-EGC2-0FA1	<p>Tool name: Tire valve driver</p> <p>Function: To disassemble and assemble an air needle in the inner tube of a tire.</p> <p>Specification: Double head (6.2mm& 5.4mm)</p>	 
SD4711-EGC2-0FA1	<p>Tool name: Tire lever component</p> <p>Function: To disassemble and assemble the inner tube of a tire.</p> <p>Specification: 11 inch and 15 inch.</p>	 

SPECIAL TOOLS

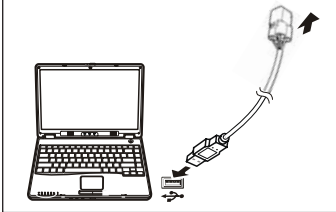
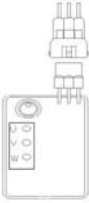

Tool NO.	Tool name / Function	Picture
SC9003-EGC2-0000	Tool name: Testing interface software Function: Only for testing driver.	
SC9004-EGC2-0000	Tool name: Testing interface connector Function: Only for connecting the driver connector and USB connector of the computer.	
SC130A-EGC2-0FG1	Tool name: Motor checking tool Function: Testing the Hall data of motor.	
SC7200-EGC2-0FG1	Tool name: Instrument panel check tools Function: Only for testing the instrument panel quality.	

CHAPTER 2

SPECIFICATIONS

SPECIFICATIONS	2-1
GENERAL SPECIFICATIONS	2-1
MAINTENENCE SPECIFICATIONS.....	2-2
CONVERSION TABLE/ GENERAL TIGHTENING	
TORQUE SPECIFICATIONS	2-4
CONVERSION TABLE	2-4
GENERAL TIGHTENING TORQUE SPECIFICATIONS	2-4
TIGHTENING TORQUES	2-5
CHASSIS TIGHTENING TORQUES.....	2-5
CABLE ROUTING	2-6



SPECIFICATIONS

GENERAL SPECIFICATIONS

Item	Standard
Dimensions Overall length Overall width Overall height Wheelbase Minimum ground clearance Minimum turning radius	1,550 mm (61.0 in) 650 mm (25.6 in) 1,000 mm (39.4 in) 1,050 mm (41.3 in) 115 mm (4.5 in) 1,600 mm (63.0 in)
Basic weight	50 kg (110.2 lb)
Chassis Frame type Caster angle Trail	Steel tube FRAME 24°00' 73.5 mm (2.9 in)
Tire Size front Size rear Manufacturer front Manufacturer rear Type front Type rear	2.25-14 27B 2.25-14 27B MAXXIS MAXXIS C-109R-X C-109R-X
Tire pressure (cold tire) Maximum load* *Load in total weight of rider and accessories front rear	98kg (215 LBS) 225 kPa (2.25 kgf/cm ² , 32 psi) 225 kPa (2.25 kgf/cm ² , 32 psi)
Brake Front brake type operation Rear brake type operation	Drum brake Right hand operation Drum brake Left hand operation

MAINTENANCE SPECIFICATIONS



ELECTRICITY

Item	Standard	Limit
Battery Type Battery capacity	Li-ion Mn battery 48.0 V/ 10AH	
Lights X number Headlight Tail/ brake light Turn signal light	12V 35/ 35W X1 12V 21/ 5W X1 12V 10W X4	
Fuse Fuse (main) Fuse (turn signal)	30A 10A	
Controller system Power input DC transformer output Driver output	voltage current 48V ±10V 0A ~ 30A voltage current 12V ± 1V 7A ± 0.5A voltage current 48V ± 10V 25A ± 1A	
Charger Voltage range	115V/ 230V	
Motor Type	48V Brushless DC Motor	

CONVERSION TABLE/GENERAL TIGHTENING TORQUE SPECIFICATIONS



CONVERSION TABLE

All specification data in this manual are listed in SI and METRIC UNITS.

Use this table to convert METRIC unit data to IMPERIAL unit data.

Ex.

METRIC		MULTIPLIER	=	IMPERIAL
** mm	x	0.03937	=	** in
2 mm	x	0.03937	=	0.08 in

CONVERSION TABLE

METRIC TO IMPERIAL			
	Metric unit	Multiplier	Imperial unit
Torque	m · kg	7.233	ft · lb
	m · kg	86.794	in · lb
	cm · kg	0.0723	ft · lb
	cm · kg	0.8679	in · lb
Weight	kg	2.205	lb
	g	0.03527	oz
Speed	km/h	0.6214	mph
Distance	km	0.6214	mi
	m	3.281	ft
	m	1.094	yd
	cm	0.3937	in
	mm	0.03937	in
Volume/ Capacity	cc (cm ³)	0.03527	oz (Imp liq.)
	cc (cm ³)	0.06102	cu · in
	lt (liter)	0.8799	qt (Imp liq.)
	lt (liter)	0.2199	gal (Imp liq.)
Misc.	kg/mm	55.997	lb/in
	kg/cm ²	14.2234	psi (lb/in ²)
	Centigrade (°C)	9/5+32	Fahrenheit (°F)

GENERAL TIGHTENING TORQUE SPECIFICATIONS

This chart specifies tightening torques for standard fasteners with a standard ISO thread pitch. Tightening torque specifications for special components or assemblies are provided for each chapter of this manual. To avoid warpage, tighten multi-fastener assemblies in a crisscross pattern and progressive stages until the specified tightening torque is reached. Unless otherwise specified, tightening torque specifications require clean, dry threads. Components should be at room temperature.

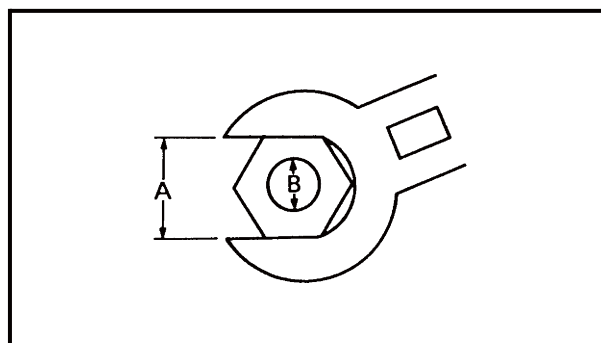

A: Distance between flats

B: Outside thread diameter

A (nut)	B (bolt)	General tightening torques		
		Nm	m · kg	ft · lb
10 mm	6 mm	6	0.6	4.3
12 mm	8 mm	15	1.5	11
14 mm	10 mm	30	3.0	22
17 mm	12 mm	55	5.5	40
19 mm	14 mm	85	8.5	61
22 mm	16 mm	130	13.0	94

TIGHTENING TORQUES



CHASSIS TIGHTENING TORQUES

Part to be tightened	Part name	Thread size	Q'ty	Tightening torque			Remarks
				Nm	m•kg	ft•lb	
Chassis							
Rear fork	Nut	M10	1	35	3.5	25.3	
Front fork	Nut	M25	2	50	5.0	36.2	See chapter 3 "ADJUSTING THE STEERING HEAD"
Rear shock absorber (up)	Bolt	M10	1	35	3.5	25.3	
Bar footrest	Bolt	M8	4	25	2.5	18.1	
Controller system	Bolt	M6	4	10	1.0	7.2	
Horn	Bolt	M6	1	10	1.0	7.2	
Hinge of seat	Bolt	M6	1	10	1.0	7.2	
Body cover	Bolt	M6	24	4	0.4	2.9	
Battery seat	Bolt	M6	4	4	0.4	2.9	
Rear fork							
Rear wheel axle	Nut	M14	2	80	8.0	57.9	
Rear shock absorber (down)	Bolt	M10	1	35	3.5	25.3	
Main stand	Bolt	M8	2	25	2.5	18.1	
Rear fender bracket	Bolt	M6	1	10	1.0	7.2	
Body cover	Bolt	M6	3	4	0.4	2.9	
Body cover	Bolt	M6	2	4	0.4	2.9	
Front fork							
Handle bar	Nut	M10	1	45	4.5	32.5	
Front shock absorber (down)	Bolt	M10	1	35	3.5	25.3	
Body cover	Bolt	M6	4	4	0.4	2.9	
Handle bar							
Speedometer comp	Bolt	M6	2	4	0.4	2.9	
Seat							
Hinge of seat	Bolt	M6	2	6	0.6	4.3	
Brake disk							
Front brake arm cam/ brake arm	Bolt	M6	2	9	0.9	6.5	

CABLE ROUTING



- | | | | |
|----|-------------------------|----|----------------------------------|
| 1 | Wire harness | 11 | UVW motor three-phases connector |
| 2 | Cable brake, rear | 12 | 6 pin connector |
| 3 | Main switch lead | 13 | Positive battery lead |
| 4 | Horn lead | 14 | Negative battery lead |
| 5 | EMI coil | 15 | tail/brake light |
| 6 | wire clamp | 16 | Turn light connector |
| 7 | Turn signal lead | A | Main switch comp |
| 8 | 12 pin connector | B | Horn |
| 9 | Starter controller lead | C | EMI coil |
| 10 | DC 12V connector | D | Turn signal relay |

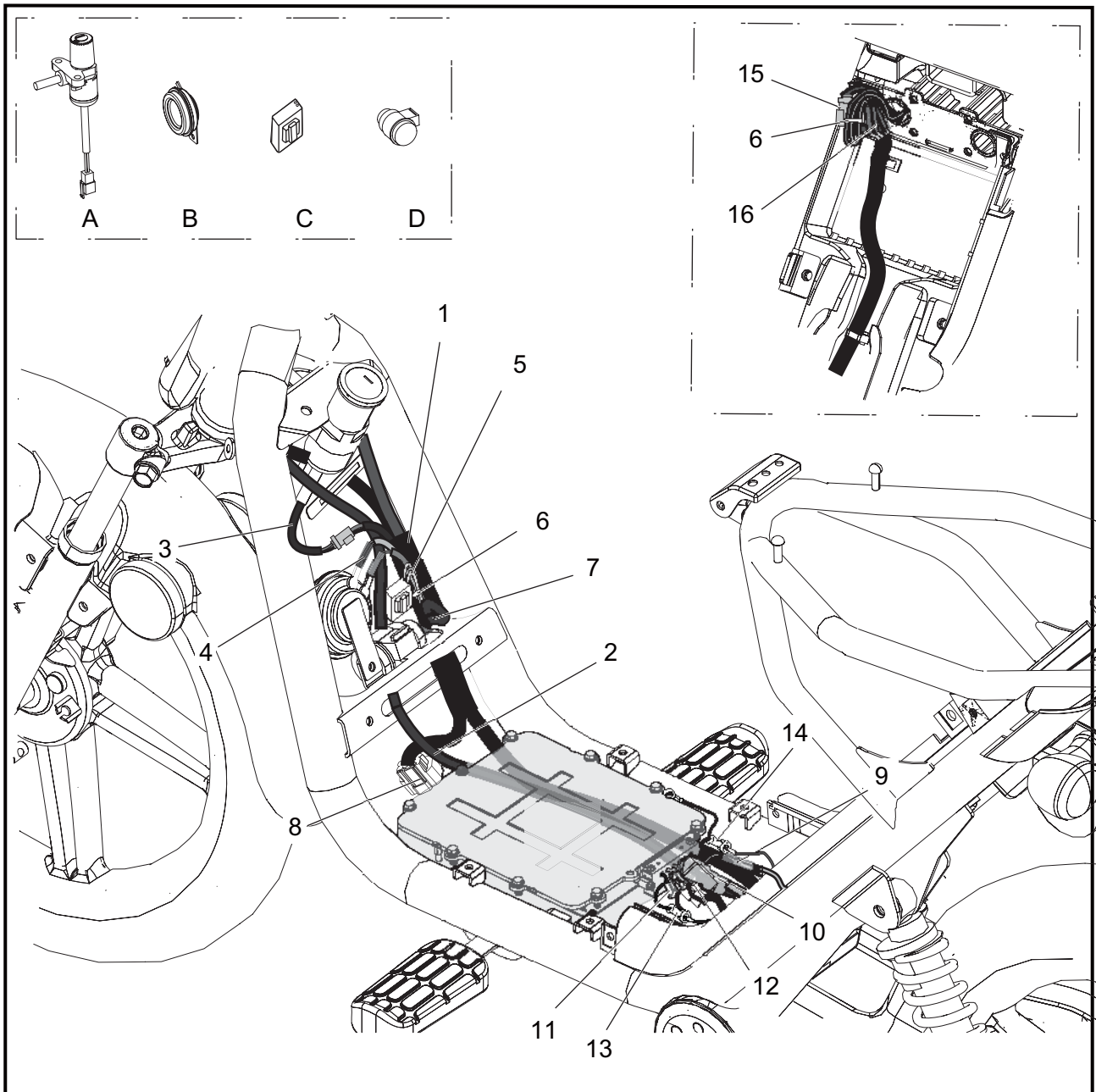

CABLE ROUTING

SPEC



- 1 Right turn light lead
- 2 Right brake lead
- 3 Cable brake, front
- 4 Throttle lead
- 5 Headlight lead
- 6 Meter connector
- 7 Horn lead
- 8 Cable brake, rear
- 9 Left brake lead
- 10 Left turn light lead

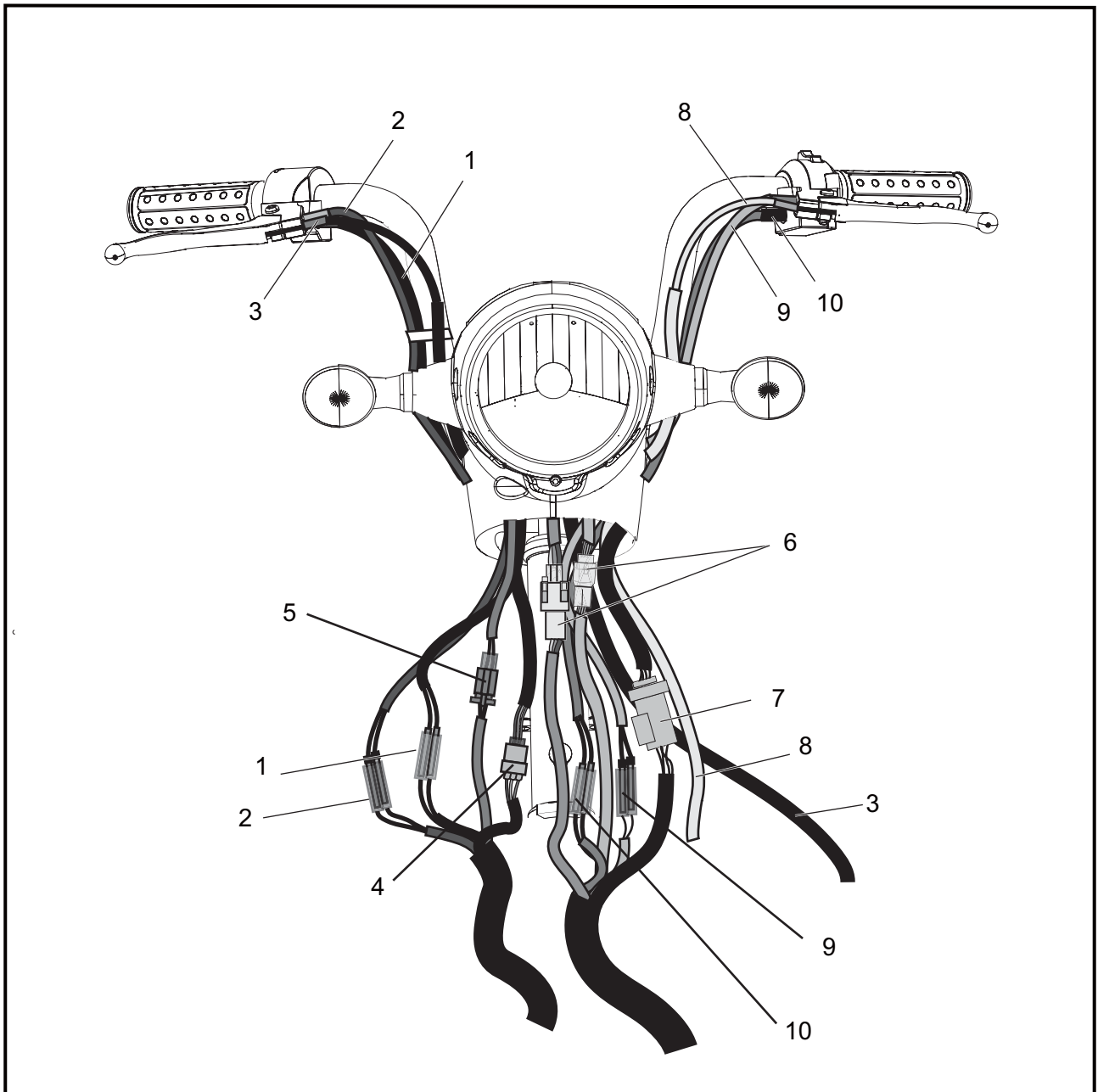

CHAPTER 3

PERIODIC CHECKS AND ADJUSTMENTS

INTRODUCTION/ PERIODIC MAINTENANCE/ LUBRICATION	3-1
SIDE COVER/ BODY COVER/ HEADLIGHT/ METER REMOVE AND INSTALL	3-2
REMOVING THE SIDE COVER AND THE BODY COVER	3-2
REMOVING SEAT/ BATTERY SEAT/ DRIVER ASSY/ BAR FOOTREST	3-3
REMOVING HEADLIGHT/ METER/ METER SIDE COVER	3-4
REMOVING AND INSTALLING REAR BOTTOM COVER/ REAR FENDER	3-5
ADJUSTMENT FRONT/REAR BRAKE FREE PLAY	3-6
CHECKING THE BRAKE SHOE	3-7
CHECKING THE STEERING SYSTEM	3-8
CHECKING THE FRONT FORK	3-9
CHECKING THE REAR SHOCK ABSORBER	3-10
CHECKING THE TIRES	3-10
CHECKING THE WHEELS	3-11
REPLACING THE HEADLIGHT BULB	3-12
REPLACING THE FRONT/ REAR TURN LIGHT BULB	3-13
REPLACING THE TAIL LIGHT BULB	3-14

PERIODIC CHECKS AND ADJUSTMENTS

INTRODUCTION

This chapter includes all information necessary to perform recommended checks and adjustments. These preventive maintenance procedures, if followed, will ensure more reliable motorcycle operation and a longer service life. The need for costly overhaul work will be greatly reduced. This information applies to motorcycles already in service as well as to new motorcycles that are being prepared for sale. All service technicians should be familiar with this entire chapter.

PERIODIC MAINTENANCE CHART FOR THE EMISSION CONTROL SYSTEM

No.	ITEM	CHECKS OR MAINTENANCE JOB	ODOMETER READING (km)							ANNUAL CHECK
			First 500km or 1 month	3000km or 3 month	5500km or 6 month	8000km or 9 month	10500km or 12 month	13000km or 15 month	15500km or 18 month	
1	* Brake (drum)	<ul style="list-style-type: none"> • Check operation and adjust brake lever free play. • Checking and replace the hose if necessary. 	Every 1,000km							
2	Tires	<ul style="list-style-type: none"> • Check tread depth and for damage. • Replace if necessary. 		√	√	√	√	√	√	
3	* Wheel bearings	<ul style="list-style-type: none"> • Check bearing for looseness or damage. Replace if necessary. 		√	√	√	√	√	√	
4	* Front fork	<ul style="list-style-type: none"> • Check operation and correct if necessary. • Replace if necessary. 		√	√	√	√	√	√	
5	* Steering bearings	<ul style="list-style-type: none"> • Check bearing play and steering for roughness. • Replace if necessary. • Lubricate with lithium-soap-based grease. 	√	√	√	√	√	√	√	
6	* Rear shock absorber assembly	<ul style="list-style-type: none"> • Check operation and for oil leakage. • Replace if necessary. 	√	√	√	√	√	√	√	
7	Main stand	<ul style="list-style-type: none"> • Check operation and lubricate. 		√	√	√	√	√	√	√
8	* Battery	<ul style="list-style-type: none"> • Check battery box for cracks or damage. • Clean 	√	√	√	√	√	√	√	√
9	Chassis fasteners	<ul style="list-style-type: none"> • Make sure that all nuts, bolts and screws are properly tightened. 	√	√	√	√	√	√	√	
10	Moving parts and cables	<ul style="list-style-type: none"> • Lubricate. 			√		√		√	√
11	Wheels	<ul style="list-style-type: none"> • Check runout and for damage, and replace if necessary. 			√		√		√	
12	Lights, signals and switches	<ul style="list-style-type: none"> • Check operation and correct if necessary • Adjust headlight beam. 	√	√	√	√	√	√	√	√
13	Front and rear brake switches	<ul style="list-style-type: none"> • Check operation and correct if necessary. 	√	√	√	√	√	√	√	√

* Since these items require special tools, data and technical skills, have an E-TON dealer perform the service.

TIP

- After 15,500 mileages has been reached or 18 months has been past, an additional maintenance shall be conducted in every 2,500 km or 2 months.
- It should check and replace ahead of time in a dirt area or rainy day.
- Please check and replace ahead of time after by long riding distance or heavy load.
- Replace the brake cable every two years or if cracked or damaged. If find the cracks or damage, should replace the new one immediately.

SIDE COVER/ BODY COVER/ HEADLIGHT/ METER REMOVE AND INSTALL



REMOVING THE SIDE COVER AND THE BODY COVER

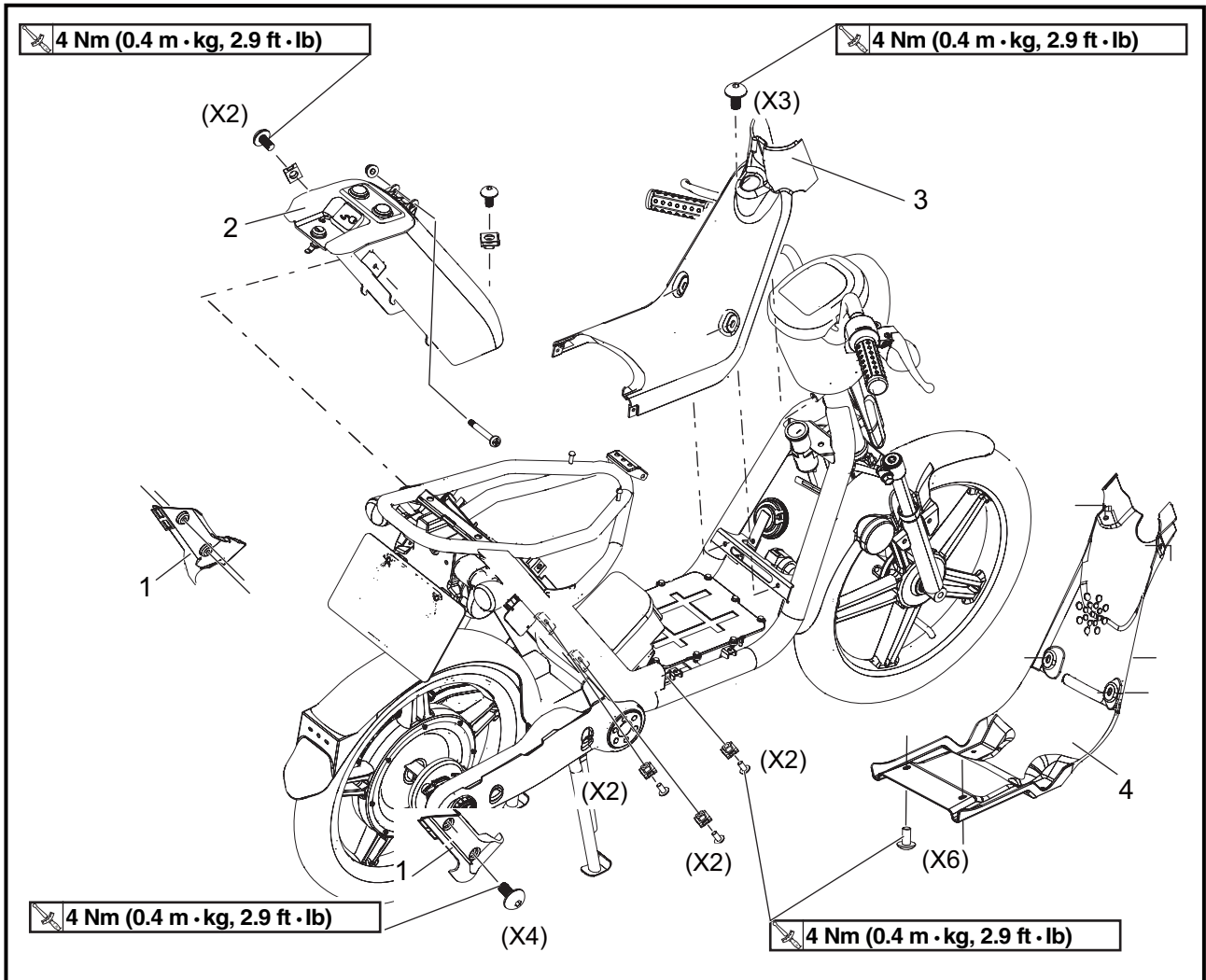

Order	Job/Part	Q'ty	Remarks
	Removing the side cover and the body cover		Remove the parts in the order listed.
1	Side cover	2	
2	Top cover (Rear)	1	
3	Top cover (Front)	1	
4	Bottom cover (Rear)	1	
			For installation, reverse the removal procedure.

SIDE COVER/ BODY COVER/ HEADLIGHT/ METER REMOVE AND INSTALL



REMOVING SEAT/ BATTERY SEAT/ DRIVER ASSY/ BAR FOOTREST

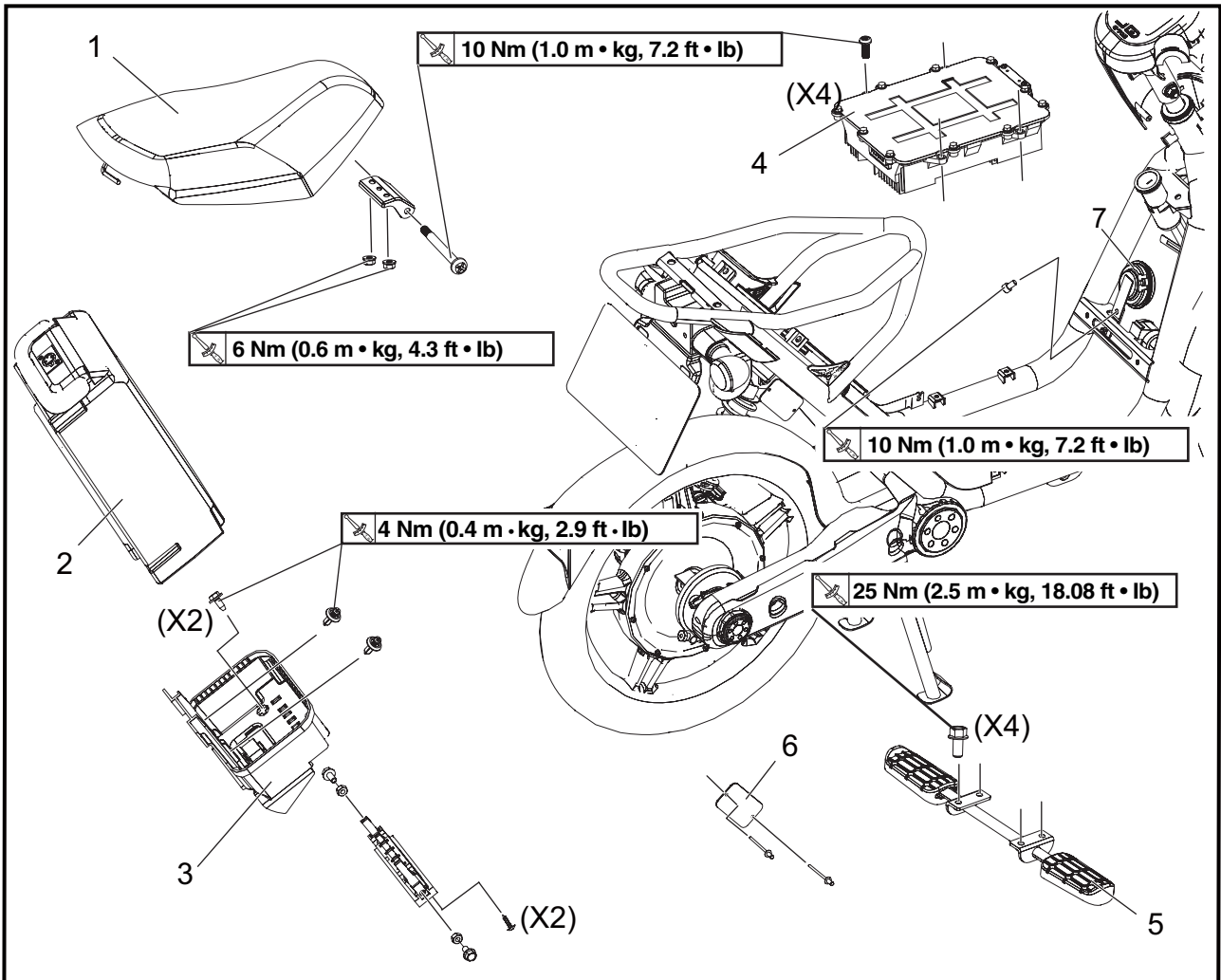

Order	Job/Part	Q'ty	Remarks
	Removing seat/ battery seat/ driver assy/ bar footrest		Remove the parts in the order listed.
1	Seat	1	
2	Battery	1	
3	Battery seat	1	
4	Driver assy	1	
5	Bar footrest	1	
6	Frame vin plate	1	
7	Horn	1	
			For installation, reverse the removal procedure.

SIDE COVER/ BODY COVER/ HEADLIGHT/ METER REMOVE AND INSTALL



REMOVING HEADLIGHT/ METER/ METER SIDE COVER

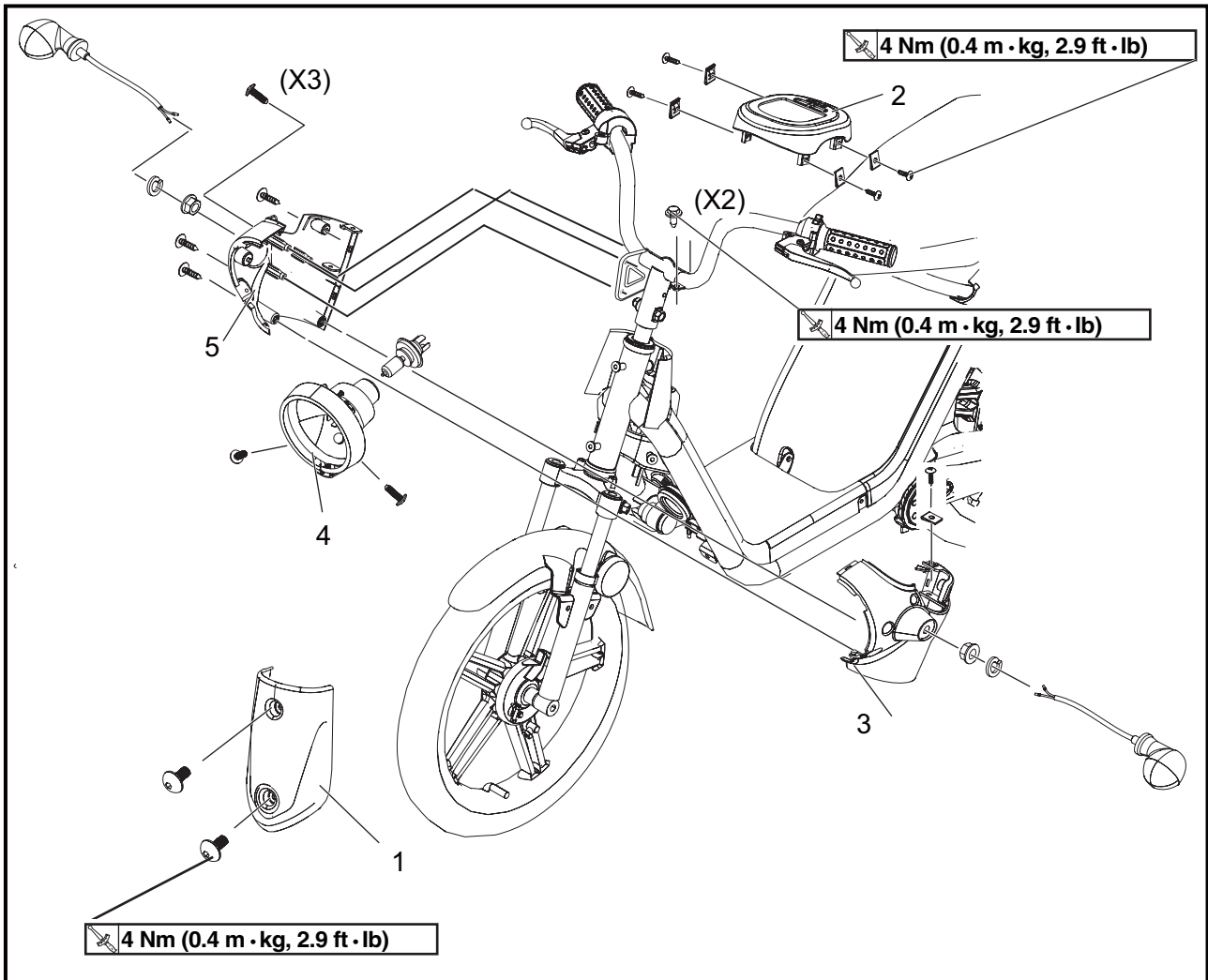

Order	Job/Part	Q'ty	Remarks
	Removing headlight/ meter/ meter side cover		Remove the parts in the order listed.
1	Front cap	1	
2	Meter	1	
3	Meter side (L)	1	
4	Headlight	1	
5	Meter side (R)	1	
			For installation, reverse the removal procedure.

REMOVING AND INSTALLING REAR BOTTOM COVER/ REAR FENDER



REMOVING REAR BOTTOM COVER/ REAR FENDER

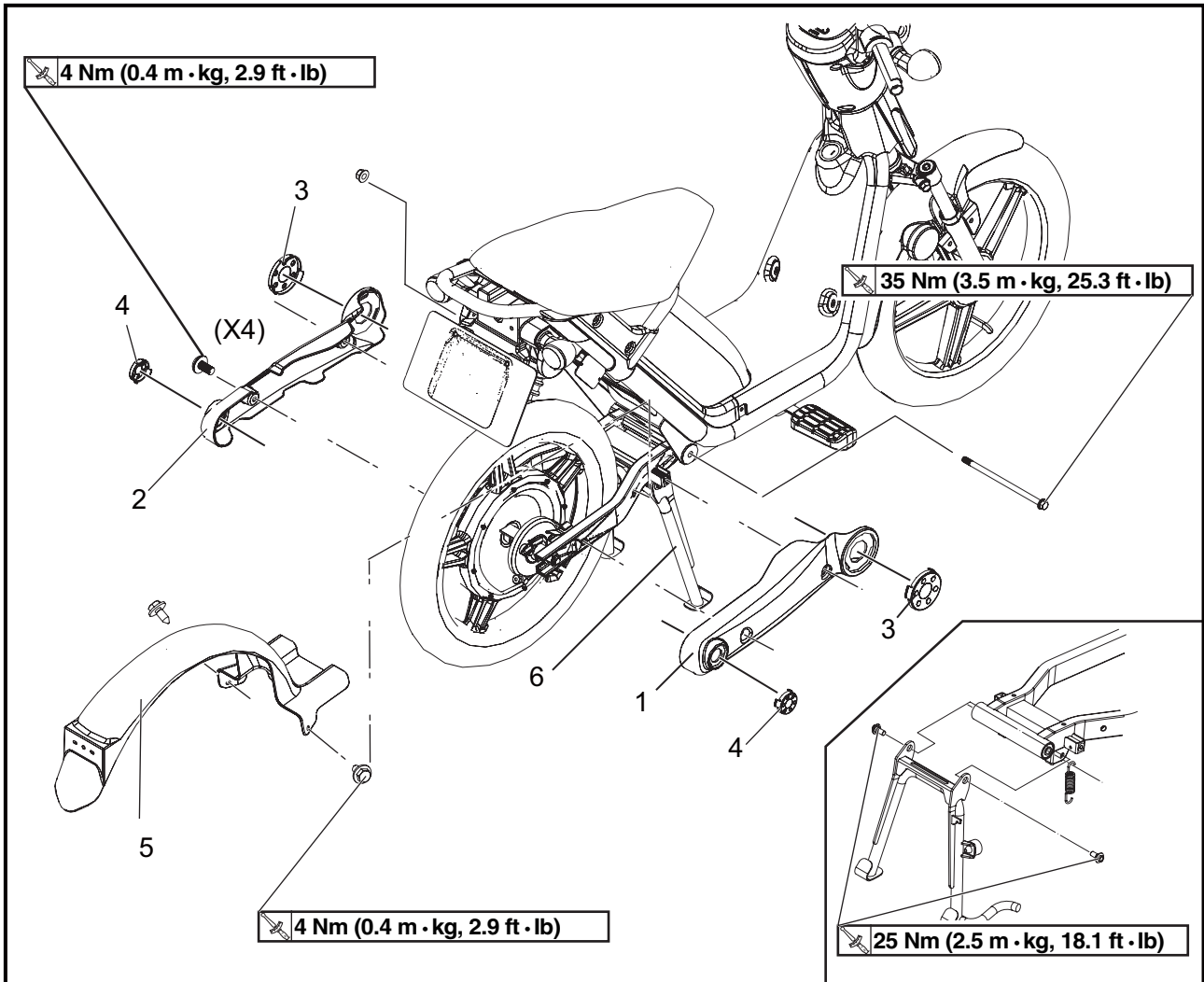

Order	Job/Part	Q'ty	Remarks
	Removing rear bottom cover/ rear fender		Remove the parts in the order listed.
1	Rear bottom cover (L)	1	
2	Rear bottom cover (R)	1	
3	Cap A	2	
4	Cap B	2	
5	Rear fender	1	
6	Main stand	1	
			For installation, reverse the removal procedure.

ADJUSTING THE FRONT/REAR BRAKE CHECKING THE BRAKE SHOES

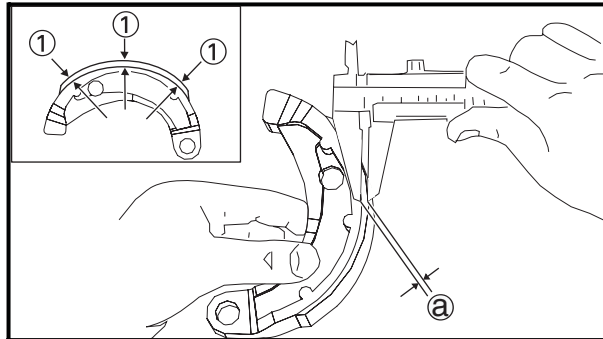
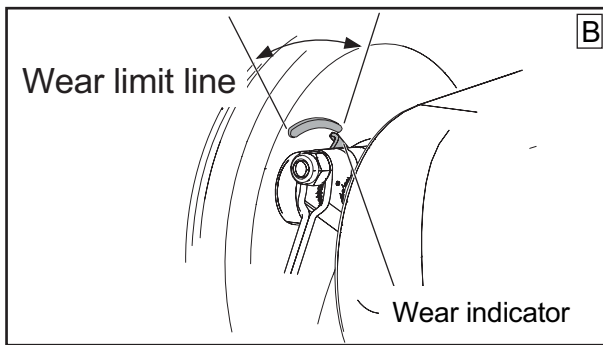
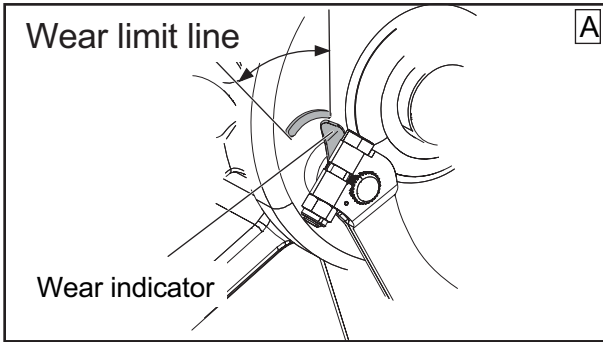

CHECKING THE BRAKE SHOES

1. Operate the brake.
2. Check
 - brake shoes
 - Wear indicators reaches the wear limit line
→ Replace the brake shoes as a set.
Refer to "REAR BRAKE" in chapter 7.
3. Adjust the front and rear brake lever free play after replace the brake shoes.

A Front brake

B Rear brake

① Measure position.

 **Brake lining wear limit ②**
1.0 mm (0.04 in)

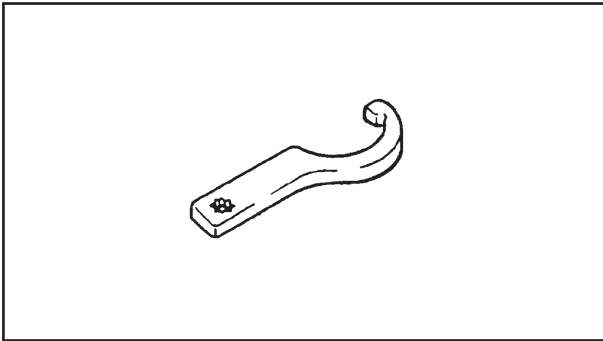

- d. Loosen the lower ring nut 1/2 turn counter-clockwise then tighten it to specification with a steering nut wrench.

	Lower ring nut (final tightening torque) 12 Nm (1.2 m • kg, 8.7 ft • lb)
---	---

- e. Check the steering head for looseness or binding by turning the front fork all the way in both directions. If any binding is felt, remove the front fork and check the upper and lower bearing. Refer to "STEERING HEAD" in chapter 7.

- f. Hold the lower ring nuts with a ring nut wrench and tighten the upper ring nut with a steering nut wrench.

	Upper ring nut 50 Nm (5.0 m • kg, 36.2 ft • lb)
---	--



6. Install
- Side cover (R)
 - Headlight
 - Side cover (L)
 - Meter
 - Front cap

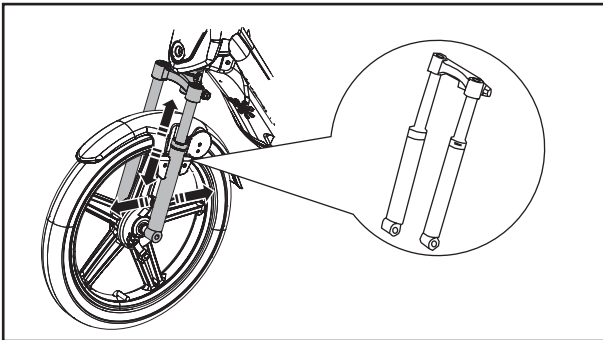

CHECKING THE FRONT FORK

1. Stand the scooter on a level surface.
2. Check
 - Front fork
Scrape/ damage → replace
3. Operation
Push down hard on the handlebar several times and check if the front fork rebounds smoothly.
Rough movement → Replace
Refer to "FROENT FORK" in chapter 7.

! WARNING

- **Securely support the scooter so that there is no danger of it falling over.**
- **If there is any abnormal sound, please replace immediately.**

CHECKING THE REAR SHOCK ABSORBER

1. Stand the scooter on a level surface.
2. Check:
 - Oil leakage/ crack/ damaged → Replace the rear shock absorber assembly.
 - Spring Damage/wear → the rear shock absorber assembly.
Refer to " REAR SHOCK ABSORBER " in chapter 7.
 - Bolts
Loosen → tighten.
Upper/lower Bolts ①.

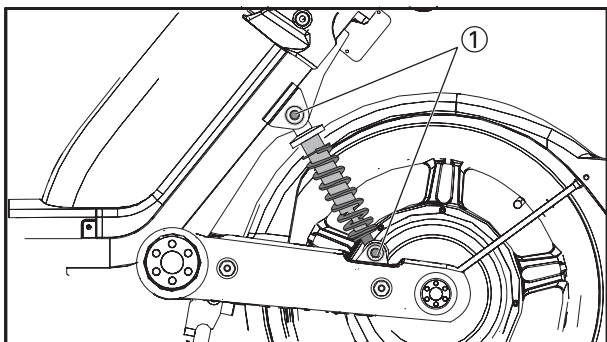

 Upper Bolt, 35 Nm (3.5 m • kg, 25.3 ft • lb)

 Lower Bolt, 35 Nm (3.5 m • kg, 25.3 ft • lb)

⚠ WARNING

The rear shock absorbers can't disassemble, improper one overhaul can cause performance reduce.

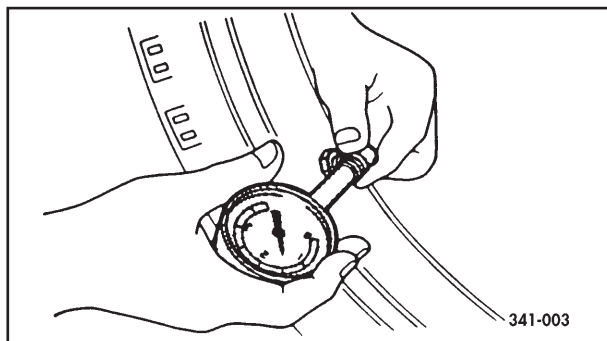

CHECKING THE TIRES

• TIRE CHARACTERISTICS

The tire characteristic effect the operation of E-MO, so the front and rear tires should always be by the same manufacturers and the specification. After extensive tests, the tires listed below have been approved by E-TON POWER TECH Co., Ltd. Using the other brands tire, because is unable to measure its characteristic of tire, may lead to the danger happen while riding, so not propose using.

	Manufacturer	Size	Type
Front	MAXXIS	2.25-14 27B	C-109R-X
Rear	MAXXIS	2.25-14 27B	C-109R-X

⚠ WARNING

Ride conservatively after installing a tire to allow it to seat itself properly on the rim.

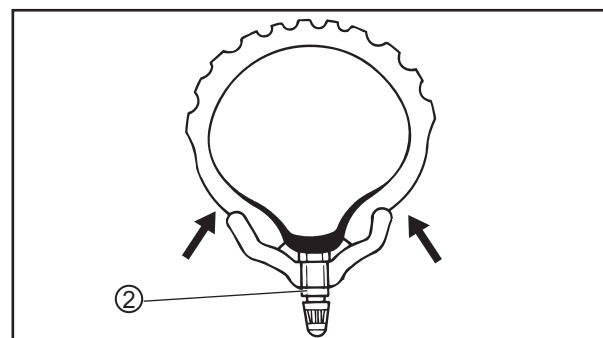
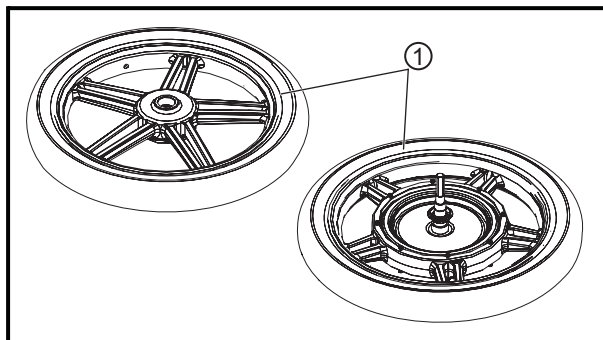
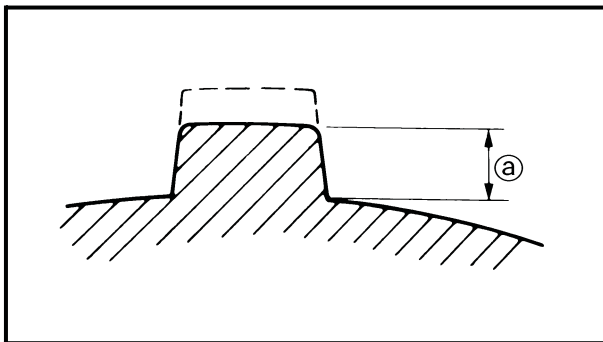
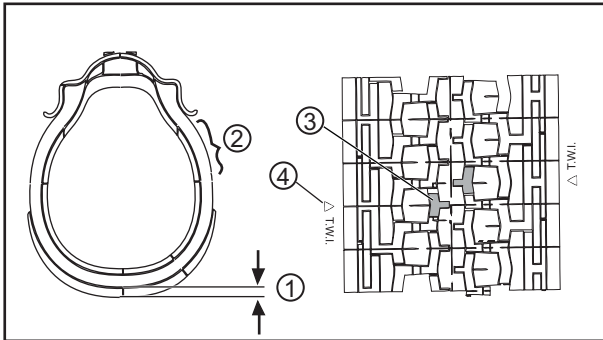

• TIRE PRESSURE

1. Measure
 - Tire pressure
 - Over specified value → Adjust.

Maximum load *	98 kg	
	Front	Rear
* Total weight of rider and accessories	225kpa. (2.25kg/cm ²)	225kpa. (2.25kg/cm ²)

2. Check:
 - Tire surfaces
 - Damage/wear → Replace the tire.



Minimum depth of thread of tires ①
0.8 mm (0.03 in)

- ① Thread depth
- ② Side wall
- ③ Wear limit line
- ④ Wear indicator

⚠ WARNING

It is dangerous to ride with a worn-out tire. When tire wear is out of specification, replace the tire immediately.

CHECKING THE WHEELS

1. Check:
 - wheel ①
 - Damage/out-of-round → Replace.
2. While adjusting and replacing the wheels, please put the inner tube into the tire and make sure the valve ② can be in the firm position.

⚠ WARNING

Never attempt to make any repairs to the wheel.

TIP

After a tire or wheel has been changed or replaced, always balance the wheel.

REPLACING THE HEADLIGHT BULB

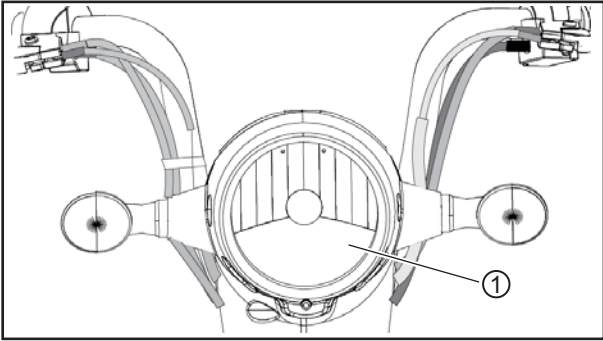

REPLACING THE HEADLIGHT BULB

1. Remove
• Headlight ① .
Refer to " REMOVING AND INSTALLING THE COVER".

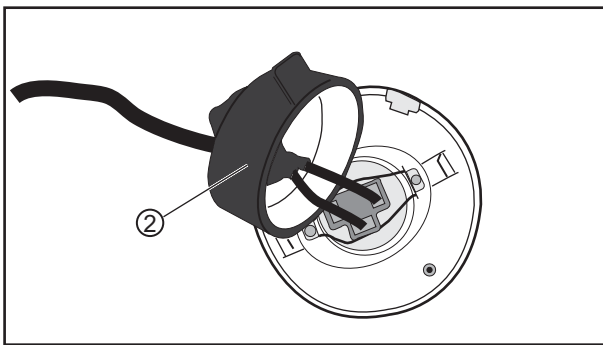

- Opening the headlight bulb holder cover ② .

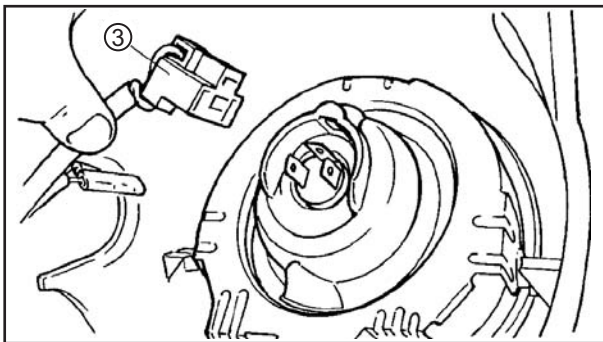

- Remove headlight coupler ③ .

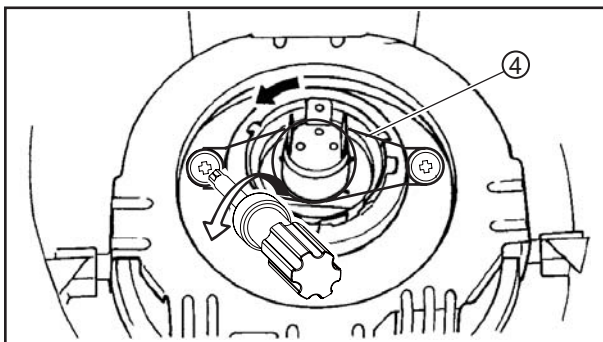

- Loosen the screw of bulb fixer ④ and the fixer will open.

REPLACING THE HEADLIGHT BULB/ REPLACING THE FRONT/ REAR TURN LIGHTS

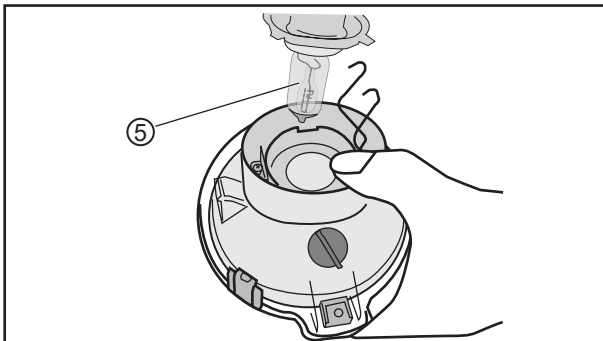

2. Change
 - Headlight bulb ⑤ (burned).

WARNING

Since the headlight bulb gets extremely hot, keep flammable products and your hands away from the bulb until it has cooled down.

3. Install
 - Headlight bulb. **New**
 - Bulb fixer.
 - Headlight coupler.
 - Bulb holder cover.
 - Headlight.

TIP

- Make sure the triangle flange of bulb connect with coupler.
- Make sure the bulb fixer infix to groove.

NOTICE

Avoid touching the glass part of the headlight bulb to keep it free from oil, otherwise the transparency of the glass, the life of the bulb and the luminous flux will be adversely affected. If the headlight bulb gets soiled, thoroughly clean it with a cloth moistened with alcohol or lacquer thinner.

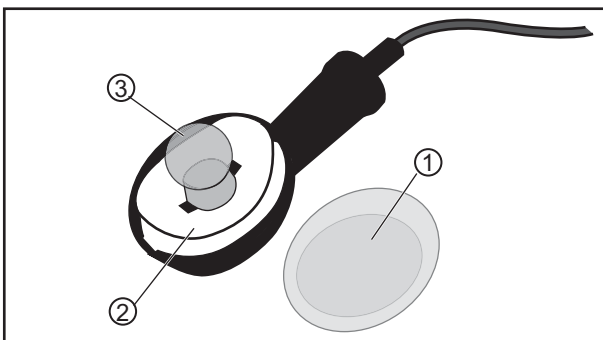

REPLACING THE FRONT/ REAR TURN LIGHT BULB

1. Remove
 - Lens ①.
 - Turn light holder site ②.
 - Bulb ③.

2. Replace
 - Bulb (burned).

TIP

- Counterclockwise (a) revolving the bulb will take it out.

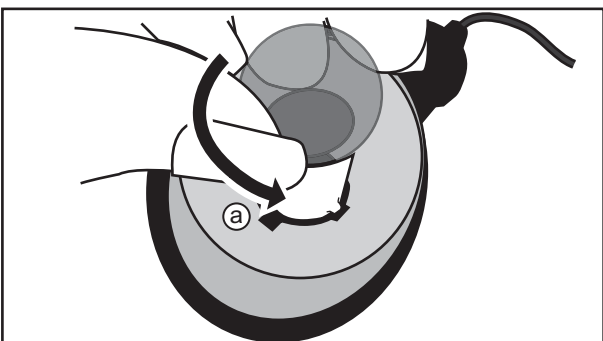

REPLACING THE FRONT/ REAR TURN LIGHTS BULB/ REPLACING TAIL LIGHT BULB

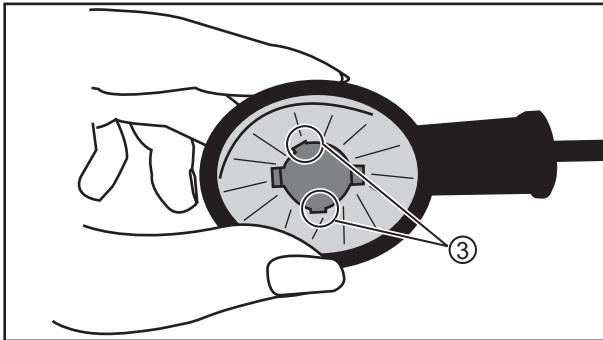

⚠ WARNING

Since the light bulb gets extremely hot, keep flammable products and your hands away from the bulb until it has cooled down.

2. Install

- Bulb. **New**
- The turn light holder site.
- Lens.
- Left/ right turn light.

TIP

- Make sure the bulb infix to groove ③.

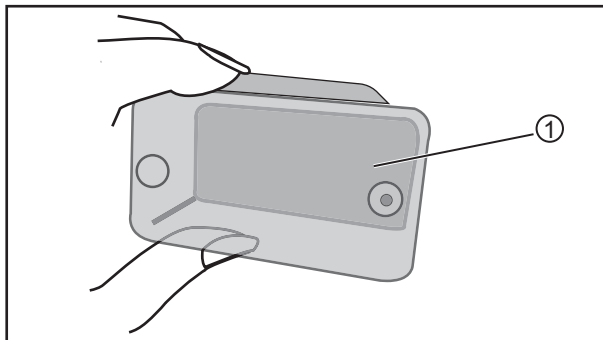

REPLACING THE TAIL LIGHT BULB

1. Remove

- Lens ①.
- Bulb ②.

TIP

- Press the bulb in and counterclockwise ② revolving will take it out.

2. Replace

- Bulb (burned).

⚠ WARNING

Since the light bulb gets extremely hot, keep flammable products and your hands away from the bulb until it has cooled down.

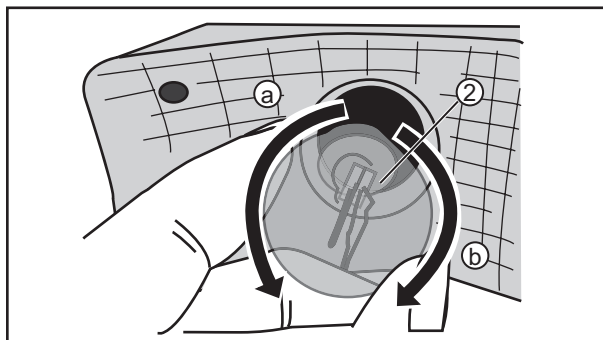

3. Install

- Bulb.
- Lens.

TIP

- Press the bulb in and clockwise ② revolving will insert into the holder site.
- Make sure the bulb infix to groove.

CHAPTER 4

CONTROLLER SYSTEM

MOTOR	4-1
CHECK AND TROUBLESHOOTING	4-1
REMOVING THE MOTOR	4-2
MOTOR INSTALLATION	4-4
DRIVER	4-5
SPECIFICATION	4-5
CHECK AND TROUBLESHOOTING	4-5
LEV INTERFACE (TESTING INTERFACE)	4-7
STATUS	4-10
INSTRUMENT PANEL	4-11
HOW TO READ INSTRUMENT PANEL	4-11
CHECK AND TROUBLESHOOTING	4-11

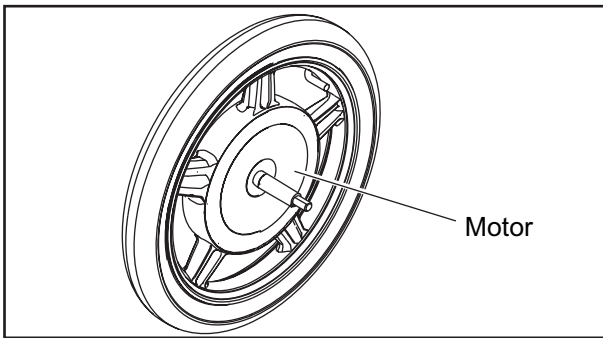

CHECK AND TROUBLESHOOTING

- When the rider control motor speed via acceleration handle, and if the motor can't run and smoothly and the instrument panel sends out a warning signal, it is necessary to check the motor.

TIP

- It is necessary to confirm relevant motorcycle components are free of failure or damage before testing.
- It is necessary to confirm the connector between the motor and controller is loosened or damaged.

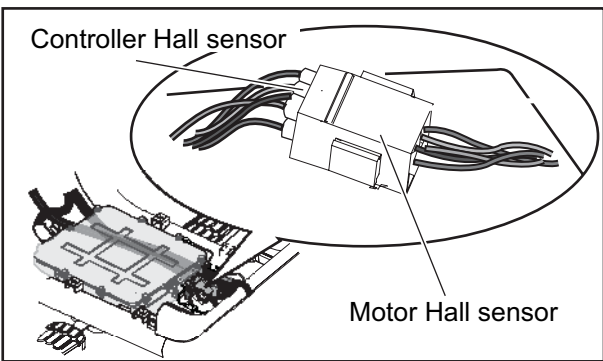

1. Testing on check tools

- Remove the Hall sensor between the motor and controller.
- Connect motor Hall sensor ① and the Hall sensor ② on the check tools and switch on the power of check tool ③.
- Turn the rear wheel by hand to confirm whether the Hall indicator (U, V, W) ④ can function normally by conducting the checking steps as in the following:

a. How to confirm Hall sensor signal functions regularly :

- Turn the rear wheel by hand. If none of Hall signal indicators doesn't remain on light-on or light-off and every indicator remains on flashing, the Hall signal can function normally.

b. How to confirm Hall Sensor signal function irregularly :

- Turn the rear wheel by hand. If any of Hall signal indicator remains on light-on or light-off and any indicator doesn't remain on flashing, the Hall signal functions irregularly. Please replace the motor.

c. If the instrument panel sends out a warning tone or warning signal :

If the instrument panel sends out a warning tone, the control system can't detect the signals of motor Hall Sensor and the motor Hall Sensor functions irregular.

The check procedures are as below:

- When the instrument panel sends out a warning tone and the Hall sensor sends out a warning signal (as illustrated in the left), please check whether motor Hall sensor and controller Hall sensor is loosened or there is poor contact.

- If wiring is regular, but there still sends out a warning signal during riding, Please replace the motor.

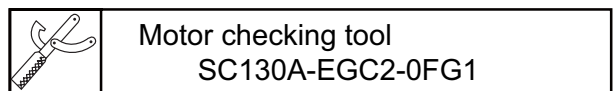
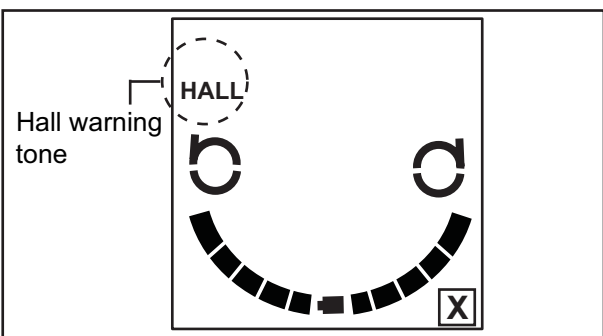
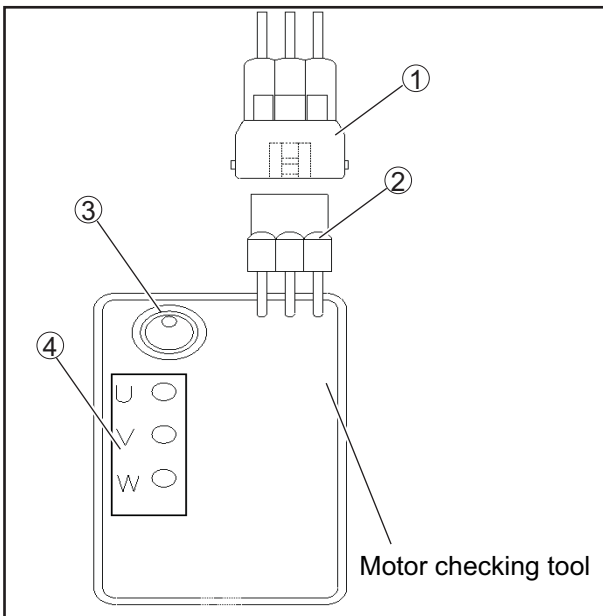

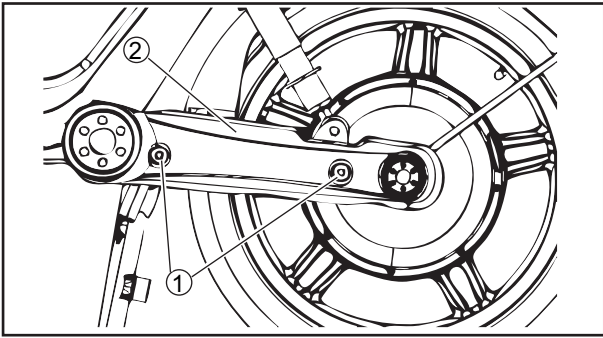

REMOVING THE MOTOR

- Remove the bolts ① and rear bottom cover L ②.

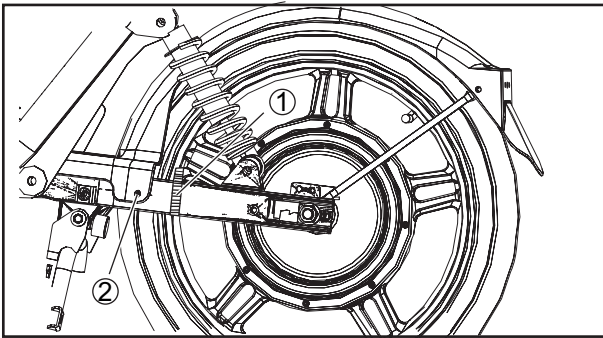

- Remove the band ① and rear fender bolt ②.

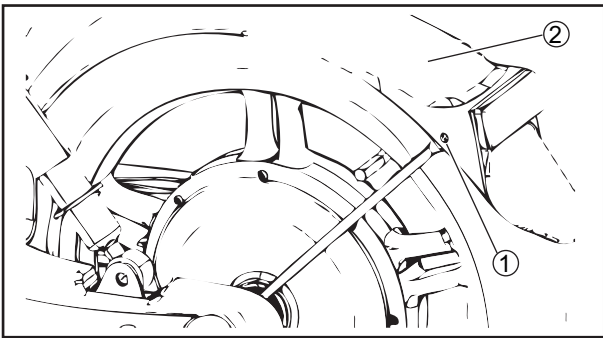

- Remove the rear fender bracket bolt ① and rear fender ②.

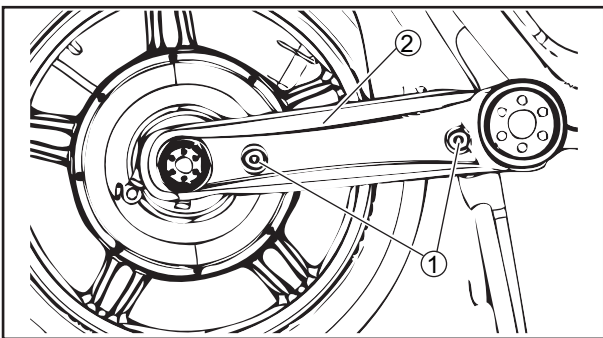

- Remove the bolts ① and rear bottom cover R ②.

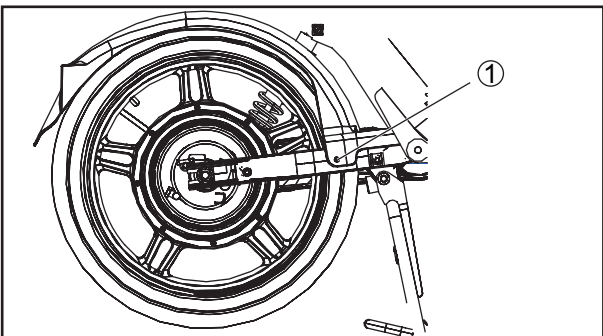

- Remove the rear fender bolt ①.

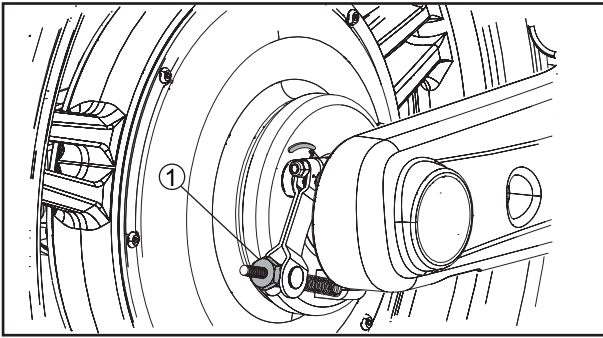

- Remove brake cable adjusting bolt ①.

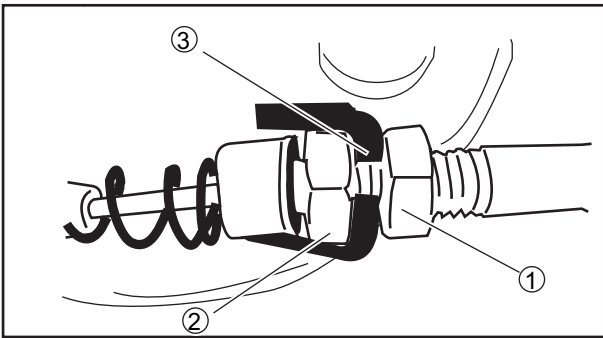

- Remove brake cable set nut ① to rear end.
- Adjust the adjusting nut ② to loosening position and fix the groove ③ across the brake drum.
- Remove brake cable.

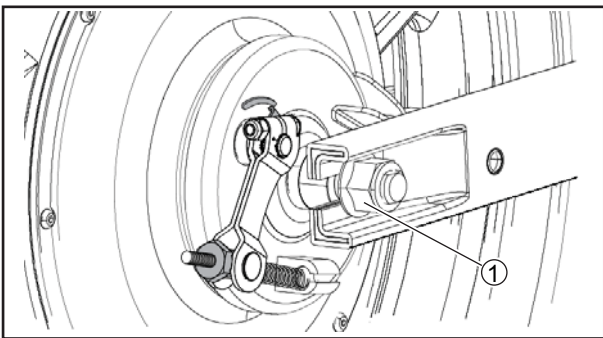

- Loosen set nuts on left and right motor and frame as illustrated.

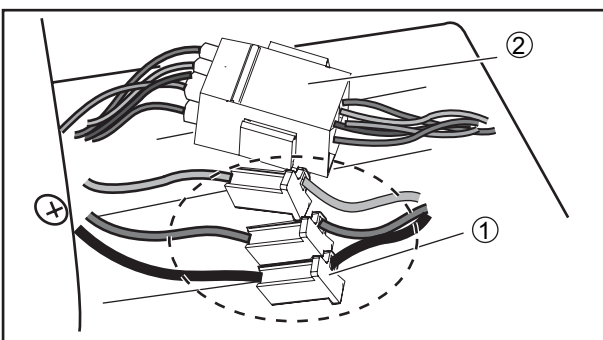

- Remove motor three-phase circuit ① and Hall connector ② as illustrated.
- Pull the three-phase circuit and Hall connector across frame gap.
- Remove the motor.

⚠ WARNING

When failed, the precise circuits and electronic component in the motor must be replaced or repaired by the authorized dealer immediately and are forbidden to be removed and decomposed by the rider to insure riding safety.

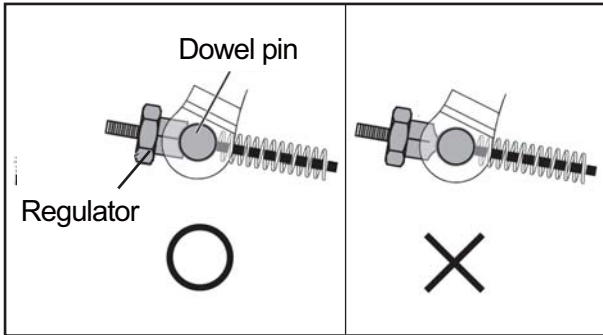

MOTOR INSTALLATION

- Reverse the removal procedure for installation.

NOTICE

- It is necessary to confirm whether the regular and dowel pin are fastened tightly during brake cable installation.
- It is necessary to check and adjust the brake clearance to maintain at 5~10mm.

⚠ WARNING

It is necessary to confirm whether brake indicator can light on and function regularly after adjusting brake.

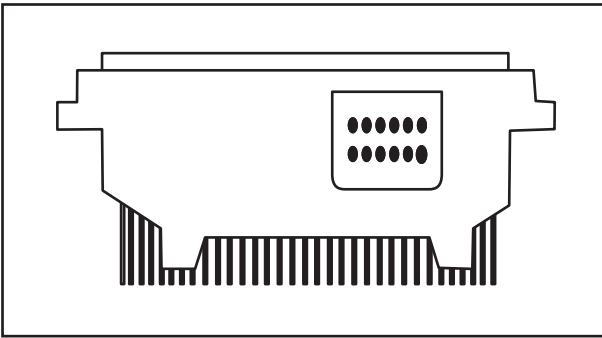

SPECIFICATION

	Voltage	Electric current
Power input	48 V ± 10 V	0 A ~ 30 A
DC transfer output	12 V ± 1 V	7 A ± 0.5 A
Motor driver output	48 V ± 10 V	25 A ± 1 A

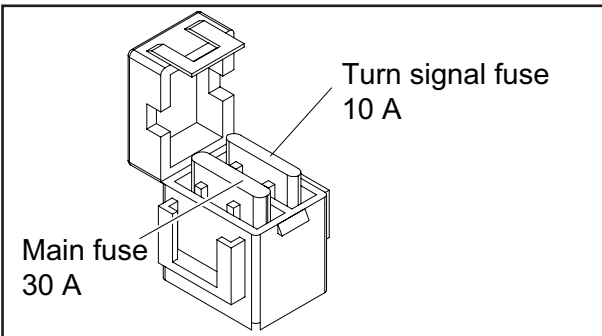

CHECK AND TROUBLESHOOTING

- Check the fuse whether blow or not.

Remove

1. Open the upper fuse cover.
2. Use a long nose pliers and pull out the fuse.

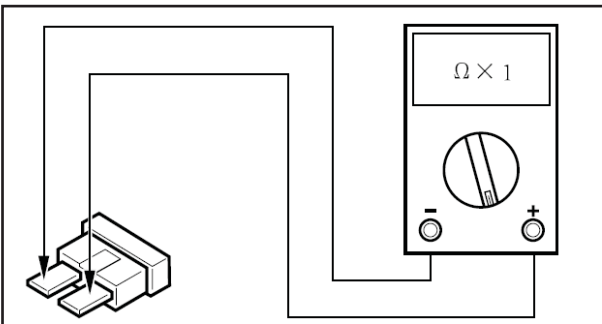

Check

1. Connect the pocket tester to the fuse and check the continuity.

TIP

Set the pocket tester selector to "Ω x 1".

- If an Avometer displays "∞", please replace the fuse.

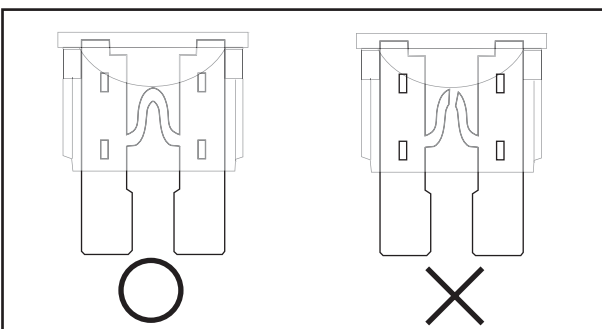

Installation

Turn the main switch to "OFF".

- Install a new fuse of the same specification and press the fuse to the bottom.
- Close and press the fuse folder cover tightly.
- Turn the main switch to "ON" and confirm each circuit system can function regularly.
- If the fuse blows out quickly again, please check each circuit system.

! WARNING

- Never use the fuse of a different specification or other metal to replace the fuse.
- Using the fuse exceeding the specified capacity will lead to wiring over-heating or blowing out.

2. Remove out wiring assembly after testing the driver according to the illustration and list below (indicated by the sign “●”): Use a pocket tester to measure. If there is any short-circuit (sending out a “Beep” tone or a measurement value of less than 0.2), it can be judged as failed.
3. Remove out wiring assembly after testing the driver according to the illustration and list below (indicated by the sign “○”): If there is not any short-circuit (without sending out a “Beep” tone or a measurement value of less than 0.2), it can be judged as failed.
4. Remove out wiring assembly after testing the driver according to the illustration and list below (indicated by digital value) and use a pocket tester to conduct ohmmeter measurement. If the measurement value exceeds the corresponding value, it can be judged as failed.

⚠ WARNING
 When failed, the precise circuits and electronic component in the controller must be replaced or repaired by the authorized dealer immediately and are forbidden to be removed and decomposed by the rider to insure riding safety.

Data for controller cable outlet

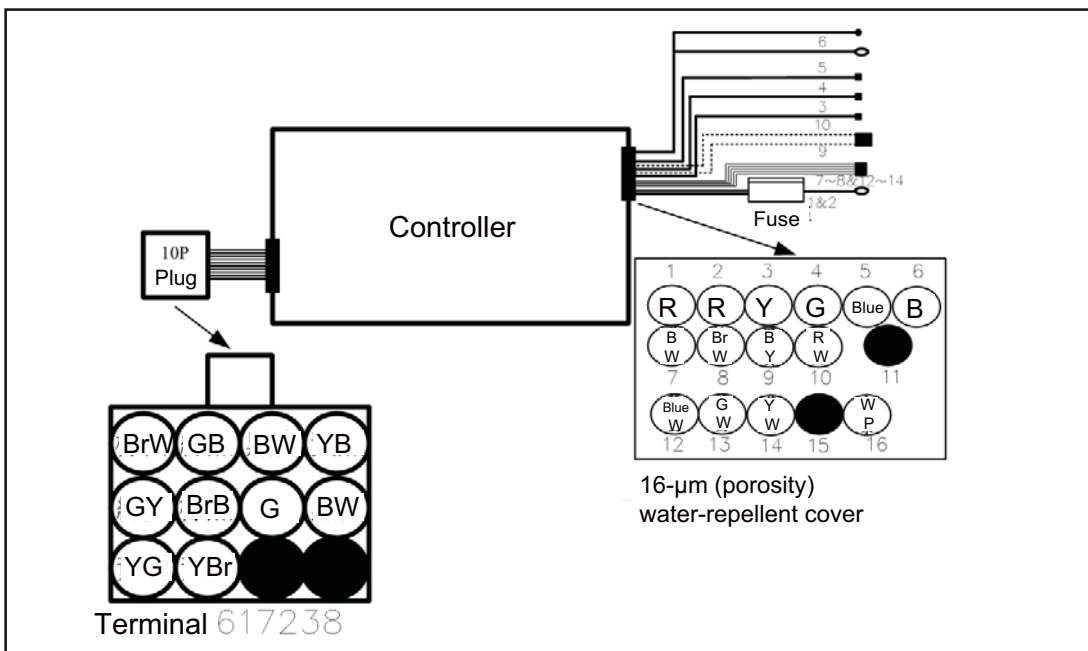

Comparison list for controller cable outlet

Cable outlet serial	3	4	5	6	7	8	9	10	12	13	14	16
1 & 2	●	●	●	●	-	-	-	●	-	-	-	-
6	●	●	●	-	○	●	○	●	3kΩ~10kΩ	3kΩ~10kΩ	3kΩ~10kΩ	120kΩ~140kΩ

" - " indicates exemption of testing.

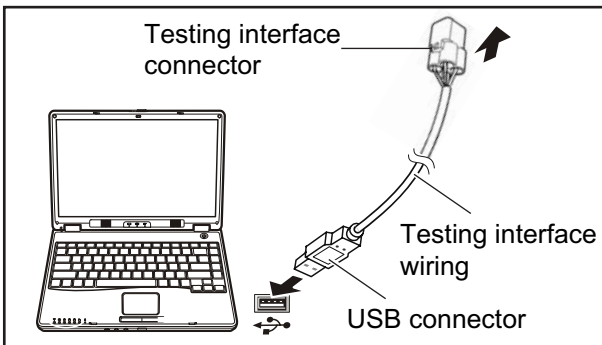
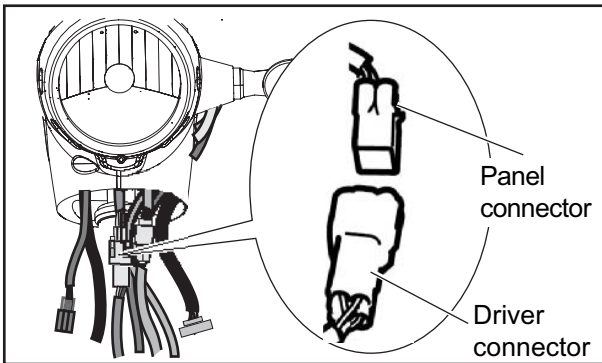

LEV INTERFACE (TESTING INTERFACE)

1. Testing: Lev Interface (testing interface)

	Testing interface software SC9003-EGC2-0000
---	--

NOTICE

List the all possible causes according to trouble-shooting and be sure to check and confirm all other causes shall be excluded before testing driver according to testing interface

How to operate testing interface

- Remove frontal fender
- Remove the connector between instrument panel and driver (as illustrated in the left) and connect the 4 pin connector of the testing interface with the driver connector and the other end connects with the UBS connector of the computer.
- Inert the key to switch on the power. Please install the testing interface software and testing interface driver by first use.

	Testing interface connector SC9004-EGC2-0000
--	---

- Start the testing interface software on the software as illustrated in the following:

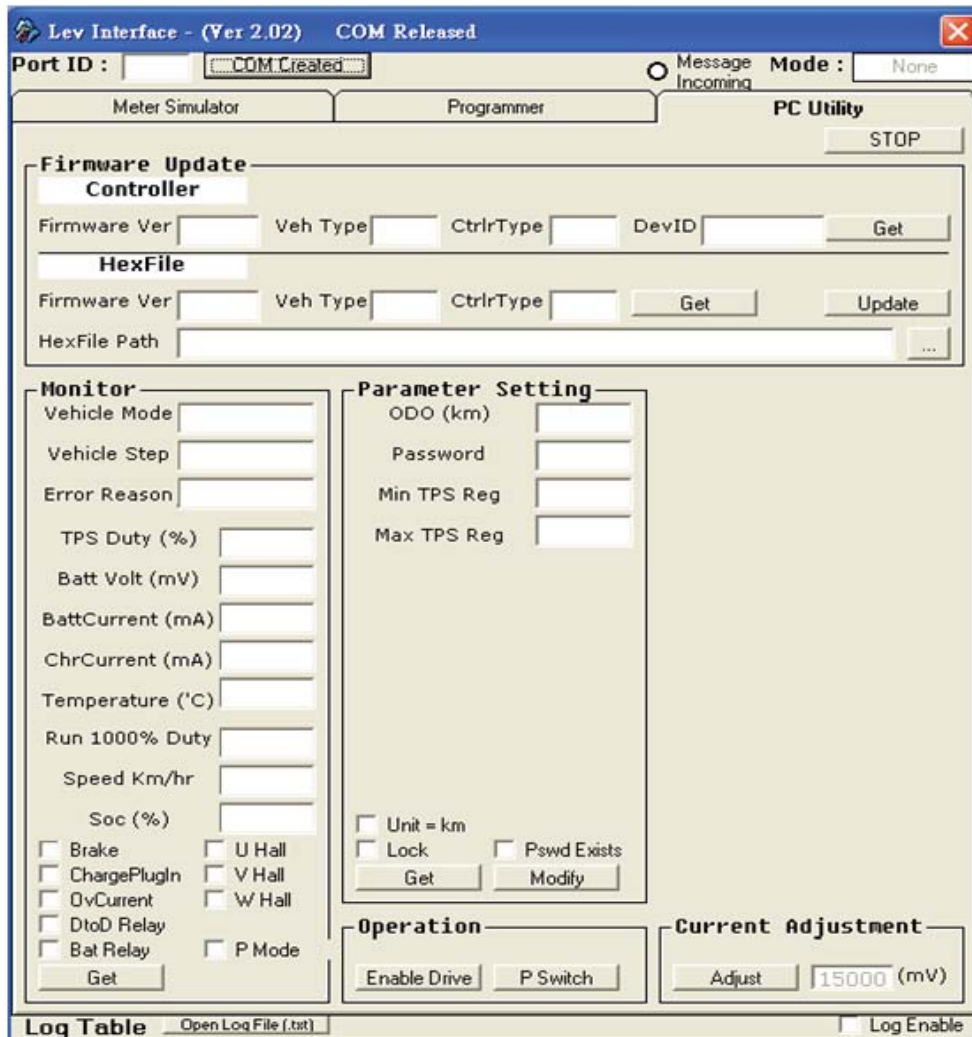

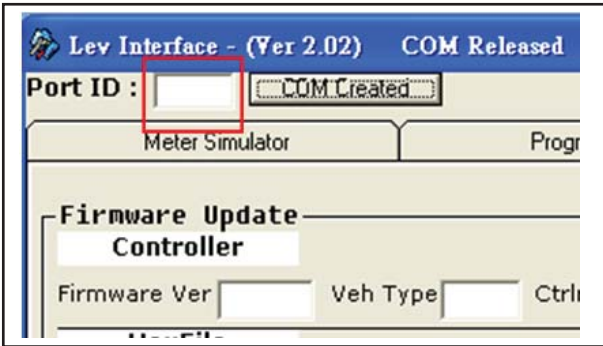

- Fill in LEV in the selected frame for connecting to the COM port of the computer, such as filling 3 for COM 3 after clicking **COM Created**.

TIP

The COM port position has gotten by click my computer → click right keyboard → click contents → click hardware → device keeper after install the testing interface software and connect driver and computer.

(The software of Windows 98, 2000, XP, Vista are suitable for use the steps.)

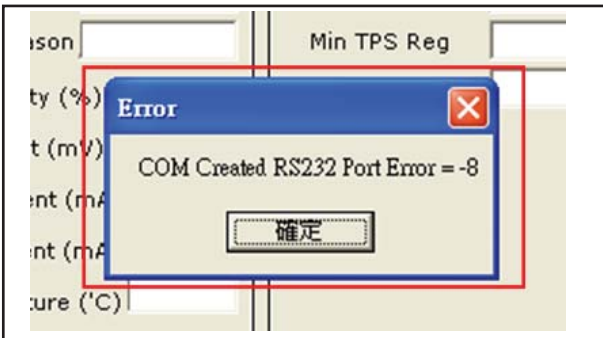

- If on-line connection fails, a wrong message window will appear as illustrated in the left. Please confirm whether the wiring connection is installed completely and COM port setting is correct.

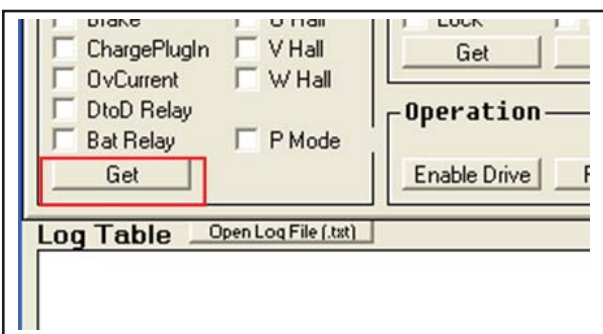

- After successful on-line connection, please click on the frame **Get**.

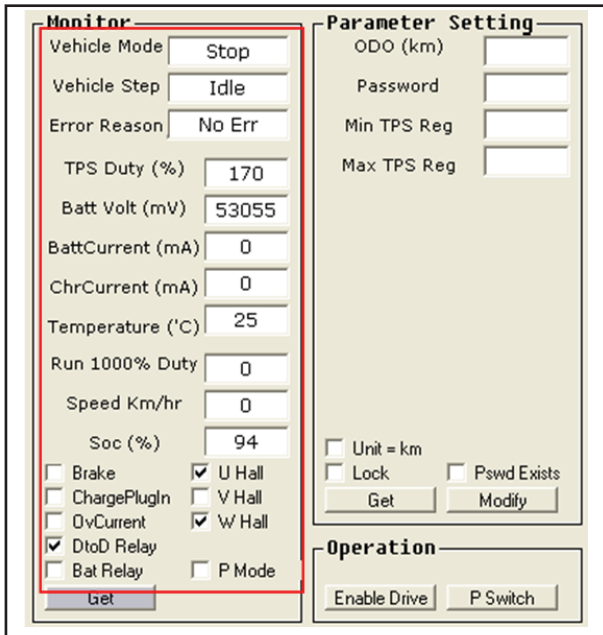

The screenshot shows a control interface with two main sections: **Monitor** and **Parameter Setting**. The **Monitor** section is highlighted with a red border and contains the following data:

Vehicle Mode	Stop
Vehicle Step	Idle
Error Reason	No Err
TPS Duty (%)	170
Batt Volt (mV)	53055
BattCurrent (mA)	0
ChrCurrent (mA)	0
Temperature (°C)	25
Run 1000% Duty	0
Speed Km/hr	0
Soc (%)	94
<input type="checkbox"/> Brake	<input checked="" type="checkbox"/> U Hall
<input type="checkbox"/> ChargePlugIn	<input type="checkbox"/> V Hall
<input type="checkbox"/> DvCurrent	<input checked="" type="checkbox"/> W Hall
<input checked="" type="checkbox"/> DtoD Relay	<input type="checkbox"/> P Mode
<input type="checkbox"/> Bat Relay	

The **Parameter Setting** section includes:

- ODO (km): []
- Password: []
- Min TPS Reg: []
- Max TPS Reg: []
- Unit = km:
- Lock: Pswd Exists:
- Buttons: Get, Modify

The **Operation** section at the bottom contains buttons for **Enable Drive** and **P Switch**.

- The controller will report the system status as shown in the selected frame.

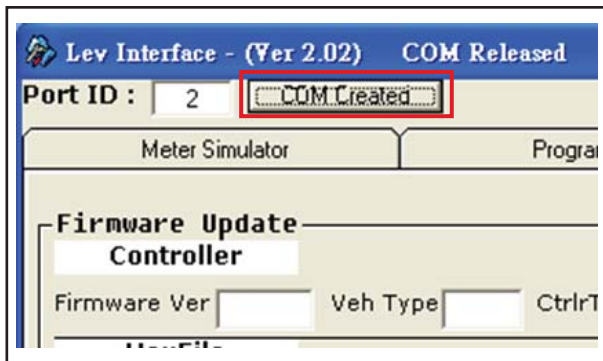

The screenshot shows the **Lev Interface - (Ver 2.02) COM Released** window. The **Port ID** is set to 2, and the **COM Release** dropdown menu is highlighted with a red border and shows the text **COM Created**. Below this, there are sections for **Meter Simulator** and **Program**. The **Firmware Update Controller** section includes fields for **Firmware Ver**, **Veh Type**, and **CtrlrT**.

- If it is necessary to leave interface testing software after completing testing, please click on the selected frame **COM Release**, and click on **COM Release**, and the switch off the software and pull off the plug to avoid software crash.

Monitor	Parameter Setting
Vehicle Mode <input type="text" value="Stop"/>	ODO (km) <input type="text"/>
Vehicle Step <input type="text" value="Idle"/>	Password <input type="text"/>
Error Reason <input type="text" value="No Err"/>	Min TPS Reg <input type="text"/>
TPS Duty (%) <input type="text" value="170"/>	Max TPS Reg <input type="text"/>
Batt Volt (mV) <input type="text" value="53055"/>	
BattCurrent (mA) <input type="text" value="0"/>	
ChrCurrent (mA) <input type="text" value="0"/>	
Temperature (°C) <input type="text" value="25"/>	
Run 1000% Duty <input type="text" value="0"/>	
Speed Km/hr <input type="text" value="0"/>	
Soc (%) <input type="text" value="94"/>	
<input type="checkbox"/> Brake <input checked="" type="checkbox"/> U Hall	<input type="checkbox"/> Unit = km
<input type="checkbox"/> ChargePlugIn <input type="checkbox"/> V Hall	<input type="checkbox"/> Lock <input type="checkbox"/> Pswd Exists
<input type="checkbox"/> OvCurrent <input checked="" type="checkbox"/> W Hall	<input type="button" value="Get"/> <input type="button" value="Modify"/>
<input checked="" type="checkbox"/> DtoD Relay	
<input type="checkbox"/> Bat Relay <input type="checkbox"/> P Mode	
<input type="button" value="Get"/>	
	Operation
	<input type="button" value="Enable Drive"/> <input type="button" value="P Switch"/>

- Monitor	
Vehicle Mode	<input type="text" value="Stop"/>
Vehicle Step	<input type="text" value="Idle"/>
Error Reason	<input type="text" value="No Err"/>
TPS Duty (%)	<input type="text" value="170"/>
Batt Volt (mV)	<input type="text" value="53055"/>
BattCurrent (mA)	<input type="text" value="0"/>
ChrCurrent (mA)	<input type="text" value="0"/>

Run 1000% Duty	<input type="text" value="0"/>
Speed Km/hr	<input type="text" value="0"/>
Soc (%)	<input type="text" value="94"/>
<input type="checkbox"/> Brake	<input checked="" type="checkbox"/> U Hall
<input type="checkbox"/> ChargePlugIn	<input type="checkbox"/> V Hall
<input type="checkbox"/> OvCurrent	<input checked="" type="checkbox"/> W Hall
<input checked="" type="checkbox"/> DtoD Relay	
<input type="checkbox"/> Bat Relay	<input type="checkbox"/> P Mode

STATUS

Status: Unable to starting computer booting (there is no display on the panel instrument or beep tone continues).

- Operate according the testing interface operation steps. If the illustration in the left still doesn't appear, the driver shall be replaced.

Status: If electricity shuts down during riding (the power and instrument panel display disappear)

- Operate according the testing interface operation steps. If the system report like in illustration in the left still doesn't appear, the driver shall be replaced.
- If the system report appears, connect the instrument panel connector with the driver and start the booting. After successful booting, turn the rear wheel slowly. If the electricity shuts down, the driver shall be replaced.

Status: Operate the throttle switch after the booting but the vehicle doesn't respond.

- Operate according the testing interface operation steps. After the system report status appear, turn the handle throttle. The turn range is bigger as the digits in the selected frame become bigger. If the digits don't change as the throttle switches on or off, the driver shall be replaced.

Status: The vehicle can't run smoothly and suffers.

- Operate according the testing interface operation steps. After the system report status appear, turn the rear wheel slowly. The selected frame will also change. If the selected frame doesn't change as the rear wheel turns, it means unchanged or the change doesn't proceed as in the sequence in the following list, the driver shall be replaced.

Hall logic list

Order	U-Phase Hall Voltage	V-Phase Hall Voltage	W-Phase Hall Voltage
1	√		
2	√	√	
3		√	
4		√	√
5			√
6	√		√

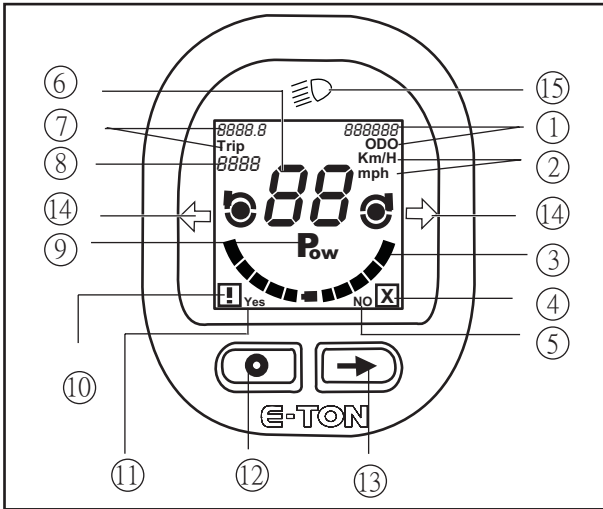

HOW TO READ INSTRUMENT PANEL

① Total mileage	⑧ Signal code
② Vehicle speed unit	⑨ Power mode
③ Battery residual power	⑩ Status warning signal
④ Failure signal	⑪ Confirmation key
⑤ Cancellation key	⑫ Button A
⑥ Speed	⑬ Button B
⑦ Single trip odometer(reset to zero)	⑭ Turn light signal
	⑮ Headlight

CHECK AND TROUBLESHOOTING

EV3 instrument panel owns simple functions and can display only status output, button input and odometer accumulation. Except that the headlight, turn signals are accessed from the electricity signal of lamps, all other signals, such as speed, electricity volume, unit (kilometers or miles), warning status are all provided by controller via RS232.

4 testing steps are described in the following to confirm whether instrument panel can function regularly or not. Each testing item describes how to judge irregular function and to make troubleshooting.

Testing steps

- After switching on the power of electric vehicle, the instrument panel beeper shall sound and LCD shall display booting screen (as illustrated in the left) and the backlight is on. It will enter into the standby screen. Press Button A ①, it will enter into riding screen.

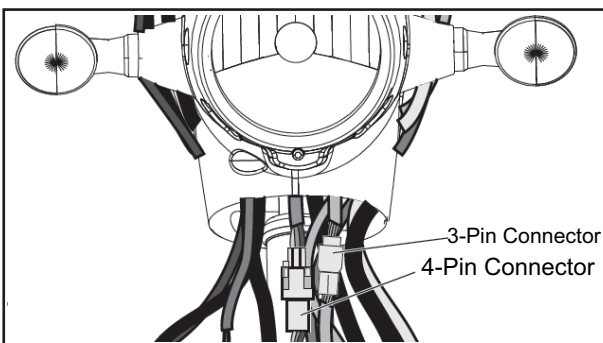
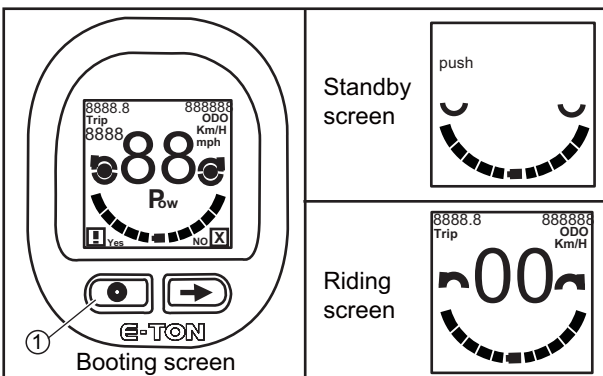

Troubleshooting 1

- There is no response and no screen on LCD after starting booting.
 - Check whether 4-pin connector is installed correctly. Make sure the installation is completed properly.

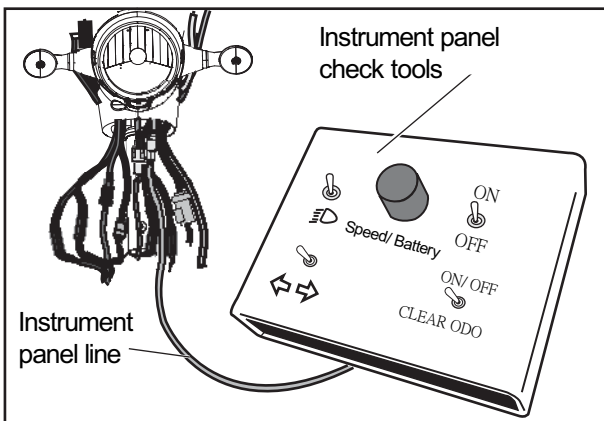
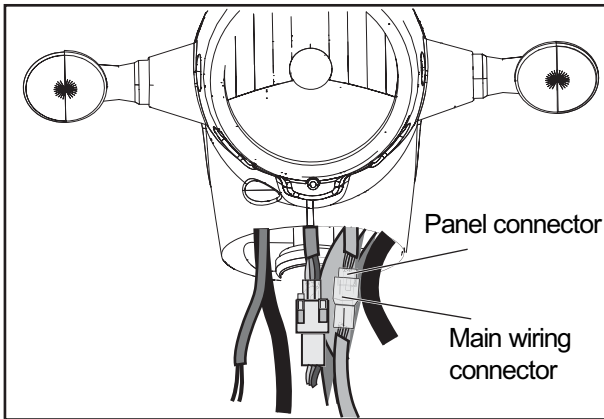

- b. After the instrument panel check tools are connected (move the panel and the 3 pin connector of main wiring and connect with the instrument panel check tools and panel connector), according to the instrument panel check tools instruction check whether the instrument panel can function regularly. If the instrument panel can't function regularly, the panel instrument shall be replaced.
- c. If the panel instrument can function regularly, use the electricity meter to measure electricity + (brown/white), - (black/white) electricity voltage at two ends of main wiring terminal of 4-Pin connector. Check whether electricity voltage of main wiring 12 V can function regularly. If the electricity voltage of main wiring 12 V functions irregularly, check the main distribution wirings.

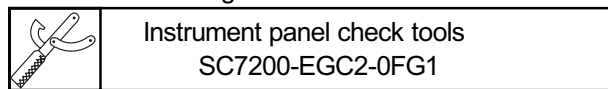

Failure status 2

- There appears broken or uneven-shading words on LCD after booting.

 - a. Connect the instrument panel check tool to confirm whether the panel instrument can function regularly. If the instrument panel functions irregularly, it is necessary to replace with a new instrument panel.

Failure status 3

- After booting, instrument panel LCD backlight is insufficient or irregular.

 - a. Connect the instrument panel check tool to confirm whether the panel instrument can function regularly. If the instrument panel functions irregularly, it is necessary to replace with a new instrument panel.

Failure status 4

- After booting, the instrument panel LCD functions regularly but the beeper doesn't sound or sound irregularly.

 - a. Check beeper connection wire or connector is installed properly. Make sure the installation is completed properly.
 - b. When poor contact is confirmed but beeper still sound irregularly, the beeper shall be replaced.

Failure Status 5

- After booting, LCD still keeps on displaying booting screen and can't enter into standby screen.

 - a. Check 4-pin connector is installed properly. Make sure the connector is installed properly.
 - b. Connect the instrument panel check tool and check whether the instrument panel can function regularly. If the instrument panel functions irregularly, it is necessary to replace with a new instrument panel.
 - c. If the instrument panel can function regularly, and the wiring connector is installed properly, it is necessary to check whether the controller can function regularly. Please refer to testing steps for the controller.

Failure status 6

- In booting screen, press the left button but it is always unable to enter into the riding screen.

 - a. Check 4-pin connector is installed properly. Make sure the connector is installed properly.

INSTRUMENT PANEL

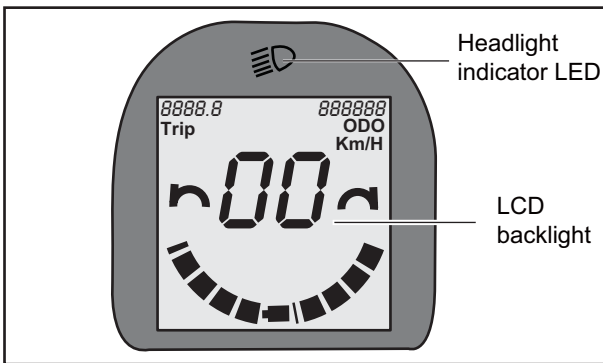
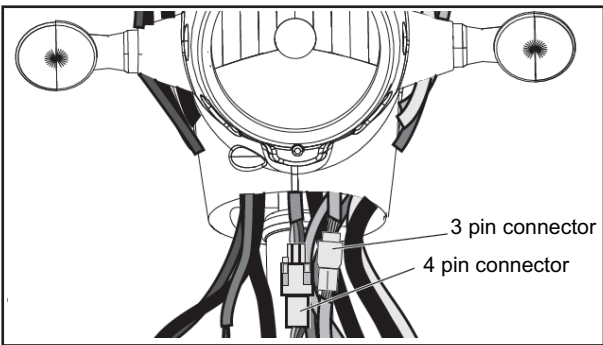
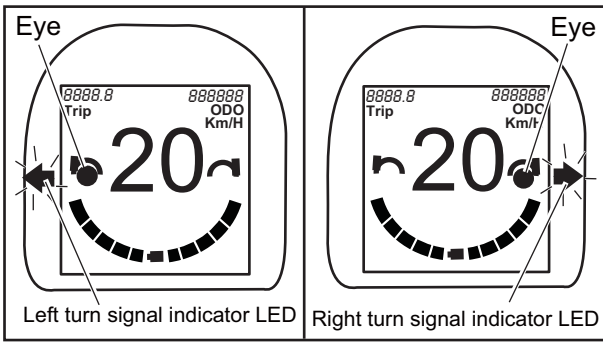

- b. Connect the instrument panel check tool and check whether the instrument panel can function regularly. If the instrument panel functions irregularly, it is necessary to replace with a new instrument panel.
- c. If the instrument panel can function regularly, and the wiring connector is installed properly, it is necessary to check whether the controller can function regularly. Please refer to testing steps for the controller.

Testing steps

2. Switch on a turn signal in riding screen. The icon "Eye" and turn signal indicator LED shall flash.

Failure Status 1

- Switch on turn signal in the riding screen, but the turn signal LED doesn't flash regularly.
 - a. Check 3-pin connector is installed properly. Make sure the connector is installed properly.
 - b. Connect the instrument panel check tool and check whether the instrument panel can function regularly. If the instrument panel functions irregularly, it is necessary to replace with a new instrument panel.
 - c. If the instrument panel can function regularly, it is necessary to check whether the turn signal and main wiring can function regularly. Please refer to Chapter 6 signal system.
- Switch on turn signal in the riding screen, but the turn signal LED doesn't flash regularly.
 - a. Check 3-pin connector is installed properly. Make sure the connector is installed properly.
 - b. Connect the instrument panel check tool and check whether the instrument panel can function regularly. If the instrument panel functions irregularly, it is necessary to replace with a new instrument panel.
 - c. If the instrument panel can function regularly, it is necessary to check whether the turn signal and main wiring can function regularly. Please refer to Chapter 6 wiring diagram.

Failure Status 2

- Switch on the turn signal in riding screen and the turn signal LED flashes but the icon "Eye" in the LCD functions irregularly.
 - a. Connect the instrument panel check tool and check whether the instrument panel can function regularly. If the instrument panel functions irregularly, it is necessary to replace with a new instrument panel.

Testing Steps

3. Switch on the headlight and LCD backlight and the headlight indicator LED will be on.

Failure Status 1

- Switch the headlight in the riding screen but the headlight indicator LCD doesn't switch on.
 - a. Check 3-pin connector is installed properly. Make sure the connector is installed properly.
 - b. Connect the instrument panel check tool and check whether the instrument panel can function regularly. If the instrument panel functions irregularly, it is necessary to replace with a new instrument panel.

- c. If the instrument panel can function regularly, it is necessary to check whether the headlight and main wiring can function regularly. Please refer to Chapter 6 Wiring Diagram

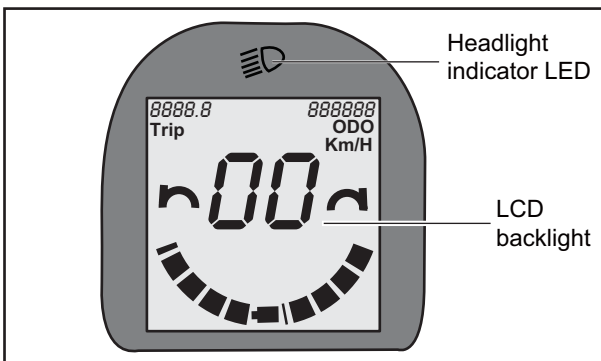
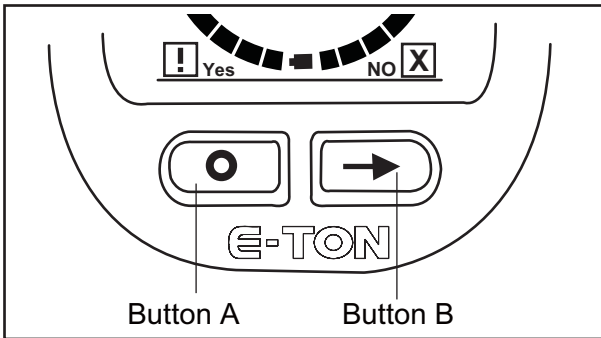

Testing Steps

4. There will sound beeper tone upon pressing Button A or Button B in the riding screen.

Failure Status 1

- The button tone doesn't sound upon pressing the left or right button in the riding screen.
 - a. Restart the booting to make sure the beeper can make booting sound effects.
 - b. If there is no booting sound effect, check whether the beeper wiring, connector, the beeper can function regularly.
 - c. If there is booting sound effect and the beeper can function regularly but there is still no button tone upon pressing the left or right button in the riding screen. Connect the instrument panel check tool to make sure the instrument panel can function regularly. If the instrument panel functions irregularly, it is necessary to replace with a new instrument panel.

Testing Steps

5. Switch on the headlight in the riding screen and the LCD backlight and the headlight indicator LED be on.

Failure Status 1

- Switch on the headlight in the riding screen but the headlight indicator LCD isn't on.
 - a. Check 3-pin connector is installed properly. Make sure the connector is installed properly.
 - b. Connect the instrument panel check tool and check whether the instrument panel can function regularly. If the instrument panel functions irregularly, it is necessary to replace with a new instrument panel.
 - c. If the instrument panel can function regularly, it is necessary to check whether the headlight and main wiring can function regularly. Please refer to Chapter 6 Wiring Diagram.

Failure Status 2

- Switch on the headlight in the riding screen and the headlight indicator LCD is on but the LCD backlight isn't on.
 - a. Connect the instrument panel check tool to check whether the instrument panel can function regularly. If the instrument panel functions irregularly, it is necessary to replace with a new instrument panel.

CHAPTER 5

BATTERY/CHARGER

BATTERY	5-1
HOW TO CHECK BATTERY RESIDUAL CAPACITY	5-1
REFERENCE VALUE FOR BATTERY RESIDUAL CAPACITY	5-2
CHECKING BATTERY	5-3
Discharge	5-3
Testing charging	5-3
CHARGER	5-4
INSTALLATION STEPS	5-4
CHARGING ELECTRICITY CURRENT AND OPERATION	
ENVIRONMENT TEMPERATURE	5-5
MAINTENANCE AND TESTING STEPS	5-5
TROUBLESHOOTING	5-6

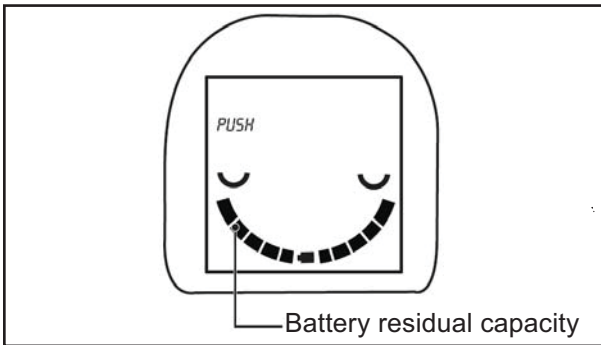

HOW TO CHECK BATTERY RESIDUAL CAPACITY

Read the battery residual capacity indicator or observe the indicator light on the battery box.

- From the battery residual capacity indicator in the display

Turn the main switch to ON. The battery residual capacity icon in the display will light fully for few seconds. The battery residual capacity will be displayed then.

- How to read the battery residual capacity indicator light from the battery box

1. Remove the battery

a. Turn the main switch to OFF

b. Lift the seat

Pull the buckle ① on the seat rear upwards and lift the seat rear upwards to open the seat.

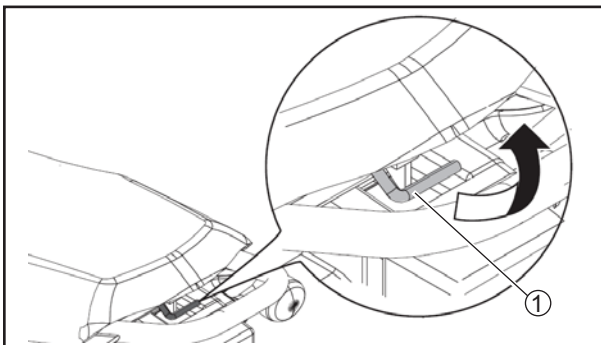

c. Use the key to open the battery protection cover and open the battery cover by hand carefully.

NOTICE

The battery protection cover will be bounced off upwards by the spring.

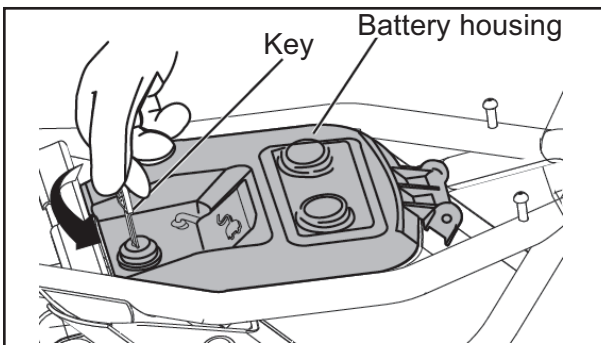

d. Hold the battery handle and pull the battery out.

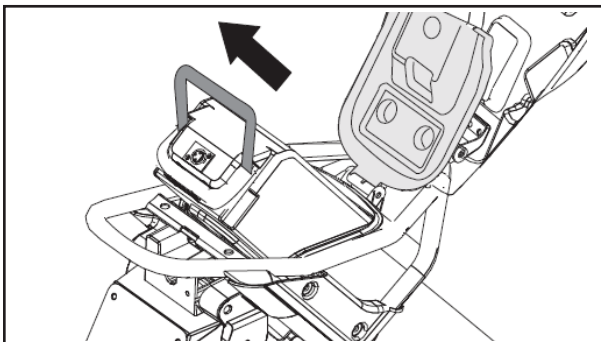

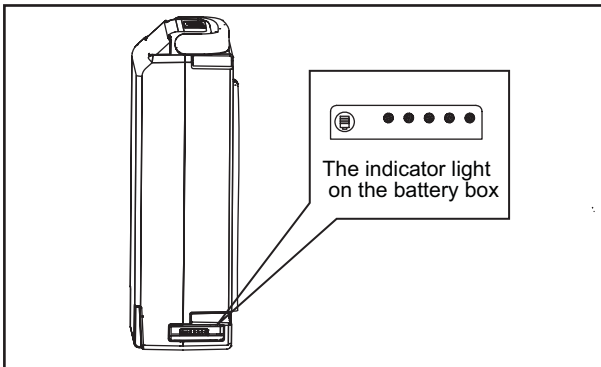

e. Remove the battery to observe the indicator light on the battery box as illustrated in the following list.

NOTICE

One of the E-MO features is Li-ion Mn battery and its performance (electric capacity) will reduce gradually. The performance reduction speed will depend on usage. Repeating charging and discharging for about 500 times will reduce electric capacity to 70%~80% of the new product.

REFERENCE VALUE FOR BATTERY RESIDUAL CAPACITY

Battery residual capacity(%)	Screen	Light signals	Situation
	■ Bright ✨ Flash	● Green ● Red	
0 ~ 24			Only 2 sections of battery residual capacity flash on the instrument panel or red light on the battery means nearly no battery residual capacity. Riding shall be stopped and charging shall be conducted immediately.
25 ~ 39			Only 2 sections of battery residual capacity on the instrument panel or 1 green light on the battery means battery is nearly out of charge and charging shall be conducted soon.
40 ~ 54			Only 4 sections of battery residual capacity on the instrument panel or 2 green light on the battery means less than half battery residual capacity. Charging shall be conducted soon.
55 ~ 69			Only 6 sections of battery residual capacity on the instrument panel or 3 green light on the battery means about 1/2 battery residual capacity. Battery capacity shall be noticed during riding.
70 ~ 84			There are 8 sections of battery residual capacity on the instrument panel or 4 green light on the battery means sufficient battery capacity.
85 ~ 100			There are 10 sections of battery residual capacity on the instrument panel or all green light on the battery means sufficient battery capacity.

※ Press on the battery box to display light signal.

TIP

Before replacing the battery, use E-Mo Charger to charge the battery completely. If the battery is not charged completely, the indicator can't display the battery residual capacity correctly.

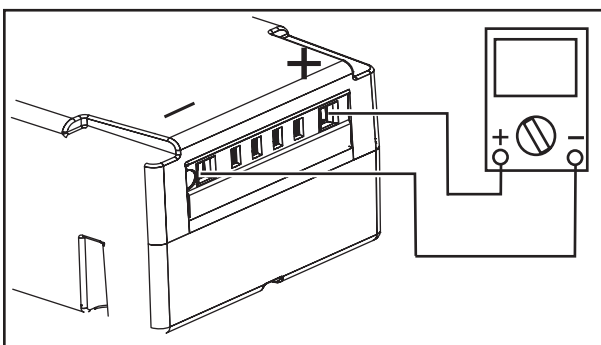
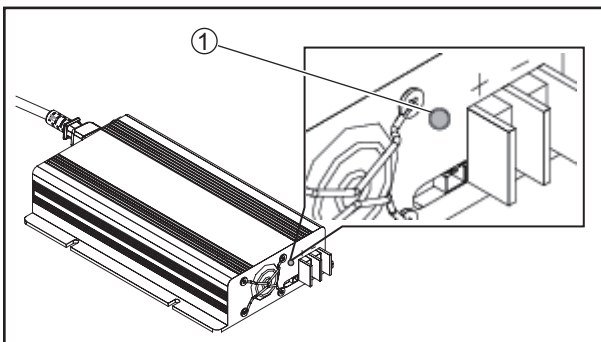
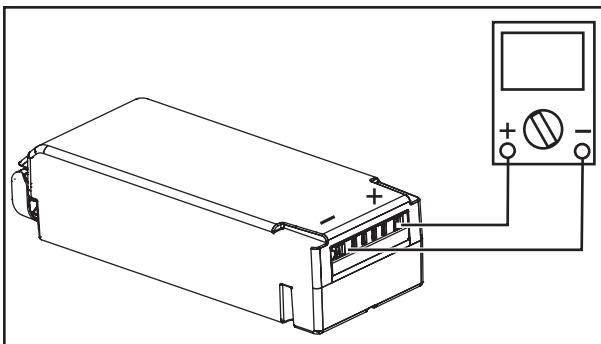
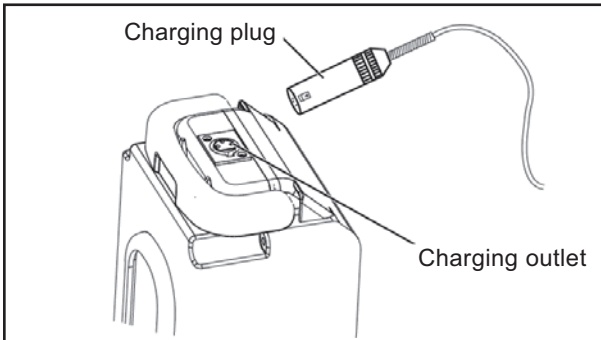
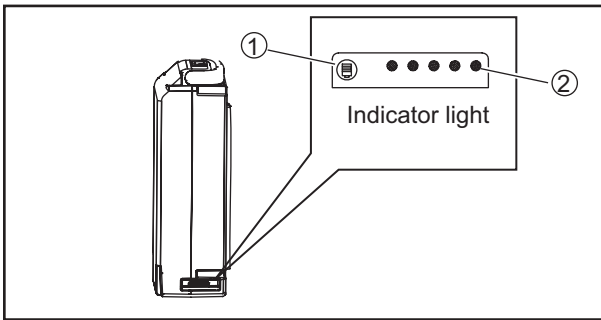

CHECKING BATTERY

• Discharge

1. Press battery residual power display button ① and observe whether LED light ② is on.
- If LED is not on, the battery might out of electricity. Please conduct the next step.

2. Plug on Charger plug and make the charger be OFF.

3. Use an ammeter to measure the output on the positive and negative poles of the battery and stay the probe on the output terminal for 10 seconds and observe whether electricity voltage is over 36V.
- If the electricity voltage is less than 36V, please replace the battery immediately.

• Testing charging

1. Plug on the charger plug and make the charger be OFF. Switch on the charger and observe whether the charger indicator ① light illuminates in red.

2. Use an ammeter to measure charging signal. Use the red probe of the ammeter to test the positive pole of the battery; the black probe to test the negative pole of the battery and then observe whether electricity voltage is more than 40V and keeps on increasing. If the electricity voltage is less than 40V, please use an ammeter to measure the negative and positive poles of the battery to observe whether the electricity voltage is more than 40V. If not, please replace with a new charger. If yes, please replace with a new battery.

CHARGER

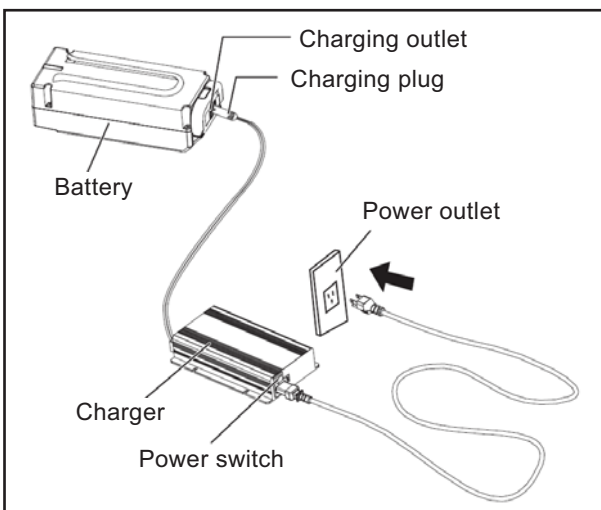
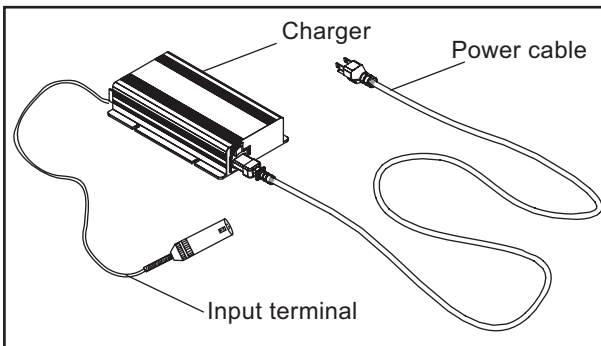
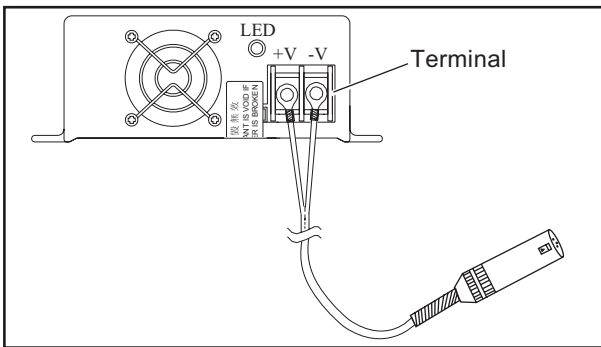
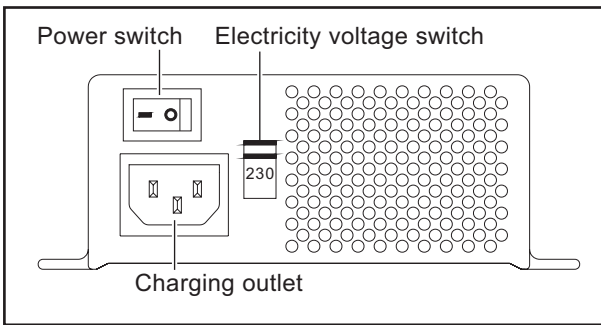

INSTALLATION STEPS

1. Make sure the charger is switched off. Connect the battery to output terminal. Select proper output wire suitable for the electricity current to act as the conducting wire between the battery and charger.

WARNING

Each pole shall be connected correctly. Positive pole (+) shall be connected to (+) terminal and negative pole (-) shall be connected to (-) terminal. Output positive and negative poles shall avoid short circuit.

2. Use selection switch to adjust the AC input electricity voltage range 115/230V according to local electricity voltage. Factory default is preset to be 115V(Taiwan).
3. After the electricity power is connected, turn the power switch (0/-) to ON(-). Check whether the LED light illuminates in red (in charging status). Green light indicates it is already fully charged.

NOTICE

- This battery can charge for the lithium battery of this vehicle.
- This charger shall be kept in drafty and dry and shall avoid exposure to rain or snow.
- The length of conducting wire connecting the battery to the charger shall be kept as short as possible to avoid lengthening the time for full charge due to excessive voltage reduction.
- Make sure the charging electricity voltage and electricity current complying with battery specification.
- Both new and old battery can't be charged in parallel connection.
- Make sure the charger is switched off upon plugging into or off the conducting wire.
- 2-year warranty is provided for the charger except damage caused by improper usage.

CHARGER

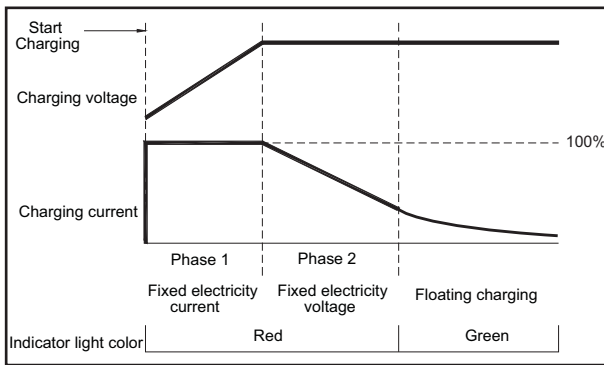

The charging electricity current and voltage in each phase is shown as in the left.

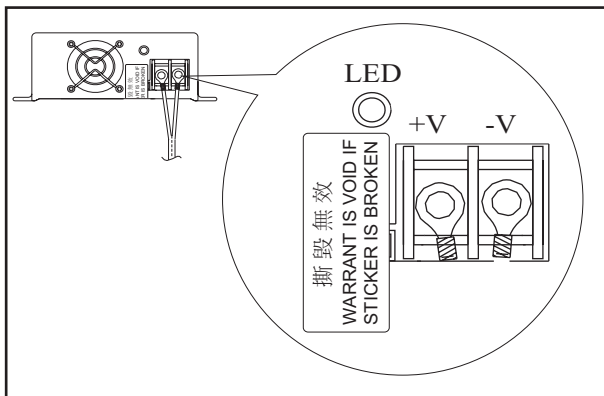

WARNING

Adjustment electricity Voltage button under the warn sticker, have already set up the voltage of charging suitable when dispatched from the factory, it will cause the damage of battery and charger to adjust by oneself. Warranty is void if sticker is broken.

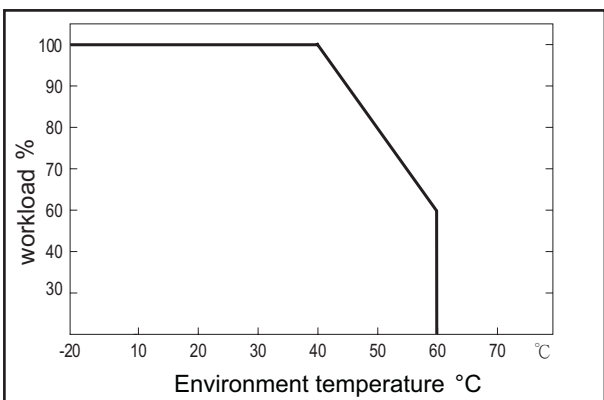

CHARGING ELECTRICITY CURRENT AND OPERATION ENVIRONMENT TEMPERATURE

1. PB-360 Charger can charge with the maximum electricity current at the temperature under 40°. The maximum electricity current will be reduced automatically at the temperature higher than 40° as shown in the left.

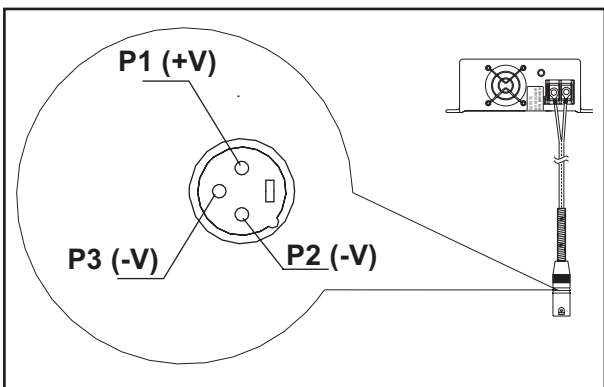

MAINTENANCE AND TESTING STEPS

1. Set the DC voltage of ammeter to over 100V.
2. The charger shall not be connected with the battery. Switch on the charger and the charger shall illuminate in green.
3. Use the red probe of the ammeter to contact the positive pole (P1) and the black probe to contact the negative (P2) as shown in the left.
4. The displaying voltage range of the ammeter is about $54.9 \pm 0.3V$
5. If the electricity voltage is not within the range mentioned above, adjust SVR1. The electricity reduces back to $54.9 \pm 0.3V$ as shown in the left.
6. If troubleshooting still can't be attained after conducting the steps mentioned above, it means the product is already damaged.



TROUBLESHOOTING

If the troubleshooting still can't be attained after conducting the steps as in the following list, please contact the E-TON Co., Ltd. or the authorized dealer.

Status	Possible cause	Solution
No output electricity voltage	Power switch is not turned to ON.	Turn to ON position
	Incorrect connection of electric pole (output fuse burned out)	Replace the fuse
	115/230VAC Incorrect selection on switch	Maintenance and repair is needed.
Excessively low output electricity voltage	115/230VAC Incorrect selection on switch	Turn the switch to the correct position
The battery charging still can't reach the floating charging phase (in green light)	Battery is aged or damaged	Replace with new battery
	Select wire of proper diameter	Excessively narrow output wire diameter

CHAPTER 6

ELECTRICAL

ELECTRICAL COMPONENTS	6-1
WIRING DIAGRAM	6-2
CHECKING SWITCH CONTINUITY	6-3
CHECKING SWITCH CONTINUITY	6-3
CHECKING THE SWITCHES	6-4
CHECKING THE BULBS AND BULB SOCKETS	6-5
CHECKING THE CONDITION OF THE BULBS	6-5
CHECKING THE CONDITION OF THE BULB SOCKETS	6-6
LIGHTING SYSTEM	6-7
CIRCUIT DIAGRAM	6-7
TROUBLESHOOTING	6-8
CHECKING THE LIGHTING SYSTEM	6-9
SIGNALING SYSTEM	6-10
CIRCUIT DIAGRAM	6-10
TROUBLESHOOTING	6-11
CHECKING THE SIGNALING SYSTEM	6-12

ELECTRICAL SYSTEM

ELECTRICAL COMPONENTS

- | | |
|-------------------|----------------------|
| 1 Main switch | 7 Switch |
| 2 Controller | 8 Horn |
| 3 Battery | 9 Meter |
| 4 Fuse | 10 Turn signal relay |
| 5 Throttle Handle | 11 Charge |
| 6 Motor | |

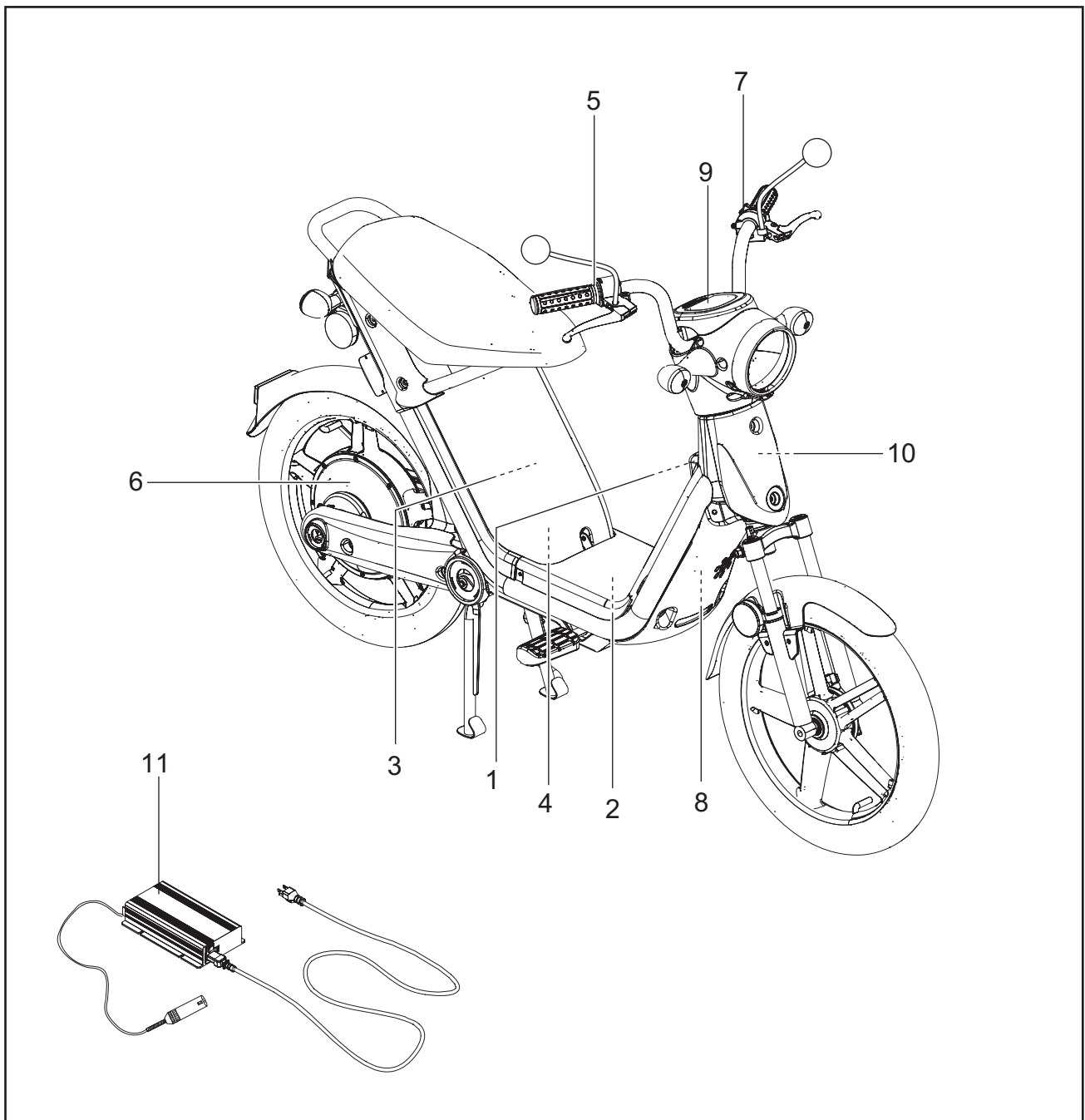

WIRING DIAGRAM

ELEC

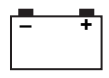

- ① Controller
- ② Meter
- ③ Motor
- ④ Fuse
- ⑤ Battery connection
- ⑥ Battery box
- ⑦ Main switch
- ⑧ Throttle handle
- ⑨ Turn signal switch
- ⑩ Horn switch
- ⑪ Headlight switch
- ⑫ Turn signal relay
- ⑬ Front brake light switch
- ⑭ Rear brake light switch
- ⑮ Front turn signal light (R)
- ⑯ Front turn signal light (L)
- ⑰ Rear turn signal light (R)
- ⑱ Rear turn signal light (L)
- ⑲ Head light
- ⑳ Tail/brake light
- ㉑ Horn
- ㉒ Protective choke coil

Color Code

- B Black
- Br Brown
- G Green
- Gr Gray
- L Blue
- LG Light Green
- Or Orange
- R Red
- Y Yellow
- Br/B Brown/Black
- BW Black/White
- B/Y Black/Yellow
- Br/W Brown/White
- Br/Y Brown/Yellow
- G/B Green/Black
- G/W Green/White
- G/Y Green/Yellow
- L/W Blue/White
- R/W Red/White
- W/Pu White/Purple
- Y/B Yellow/Black
- Y/Br Yellow/Brown
- Y/G Yellow/Green
- Y/L Yellow/Blue
- Y/R Yellow/Red
- Y/W Yellow/White

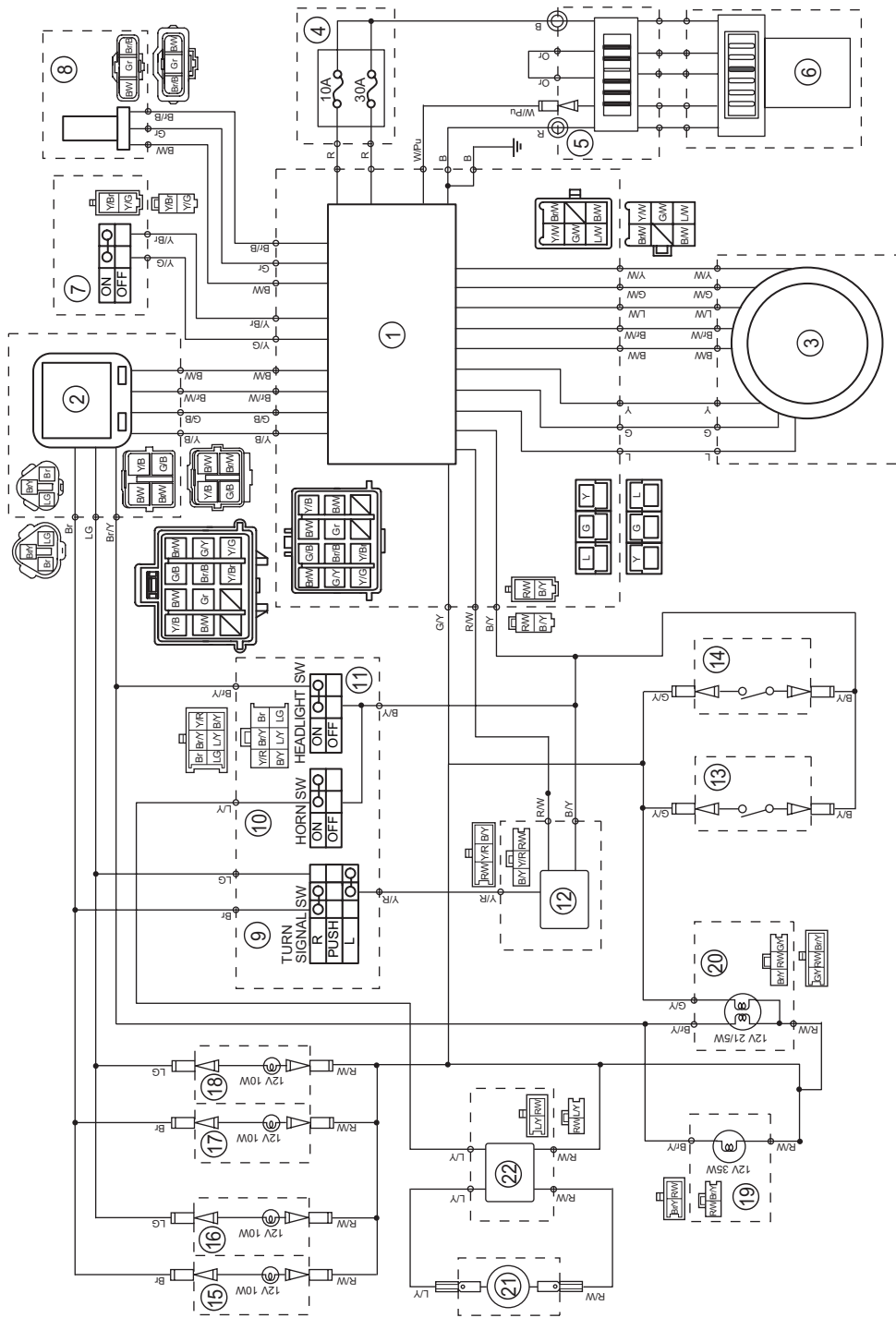

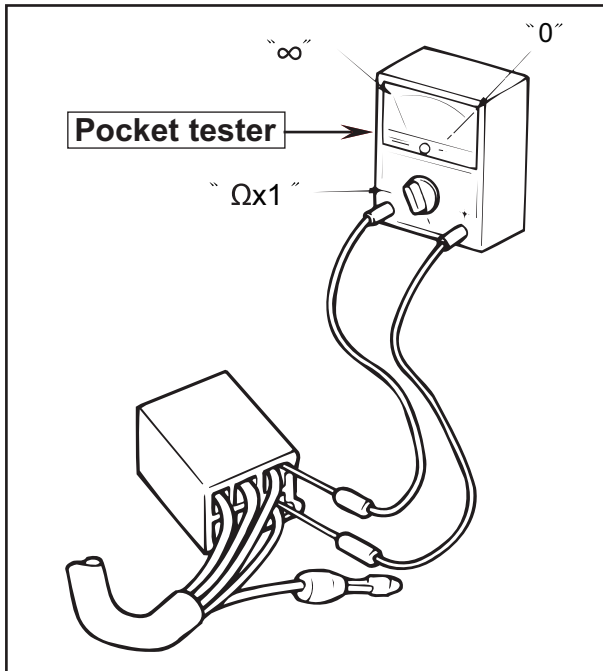

CHECKING SWITCH CONTINUITY

Check each switch for continuity with the pocket tester. If the continuity reading is incorrect, check the wiring connections and if necessary, replace the switch.

NOTICE

Never insert the tester probes into the coupler terminal slots. Always insert the probes from the opposite end of the coupler, taking care not to loosen or damage the leads.

TIP

- Before checking for continuity, set the pocket tester to “0” and to the “Ωx1” range.
- When checking for continuity, switch back and forth between the switch positions a few times.

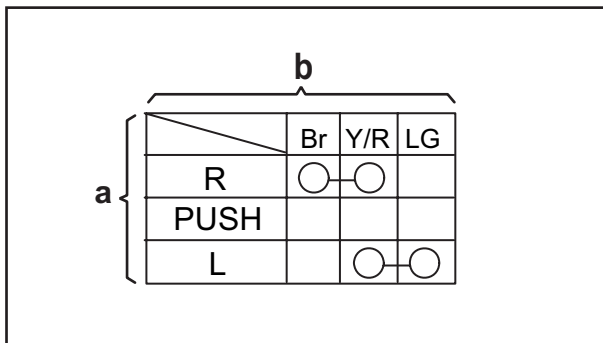

The terminal connections for switches (e.g., trunk signal switch, horn switch) are shown in an illustration similar to the one on the left.

The switch positions (a) are shown in the far left column and the switch lead colors (b) are shown in the top row in the switch illustration.

TIP

“○—○” indicates a continuity of electricity between switch terminals (i.e., a closed circuit at the respective switch position).

The example illustration on the left shows that:

There is continuity between brown and yellow/red when the switch is set to “R”.

CHECKING THE SWITCHES



CHECKING THE SWITCHES

Check each switch for damage or wear, proper connections, and also for continuity between the terminals. Refer to "CHECKING SWITCH CONTINUITY".

Damage/wear → Repair or replace.
 Improperly connected → Properly connect.
 Incorrect continuity reading → Replace the switch.

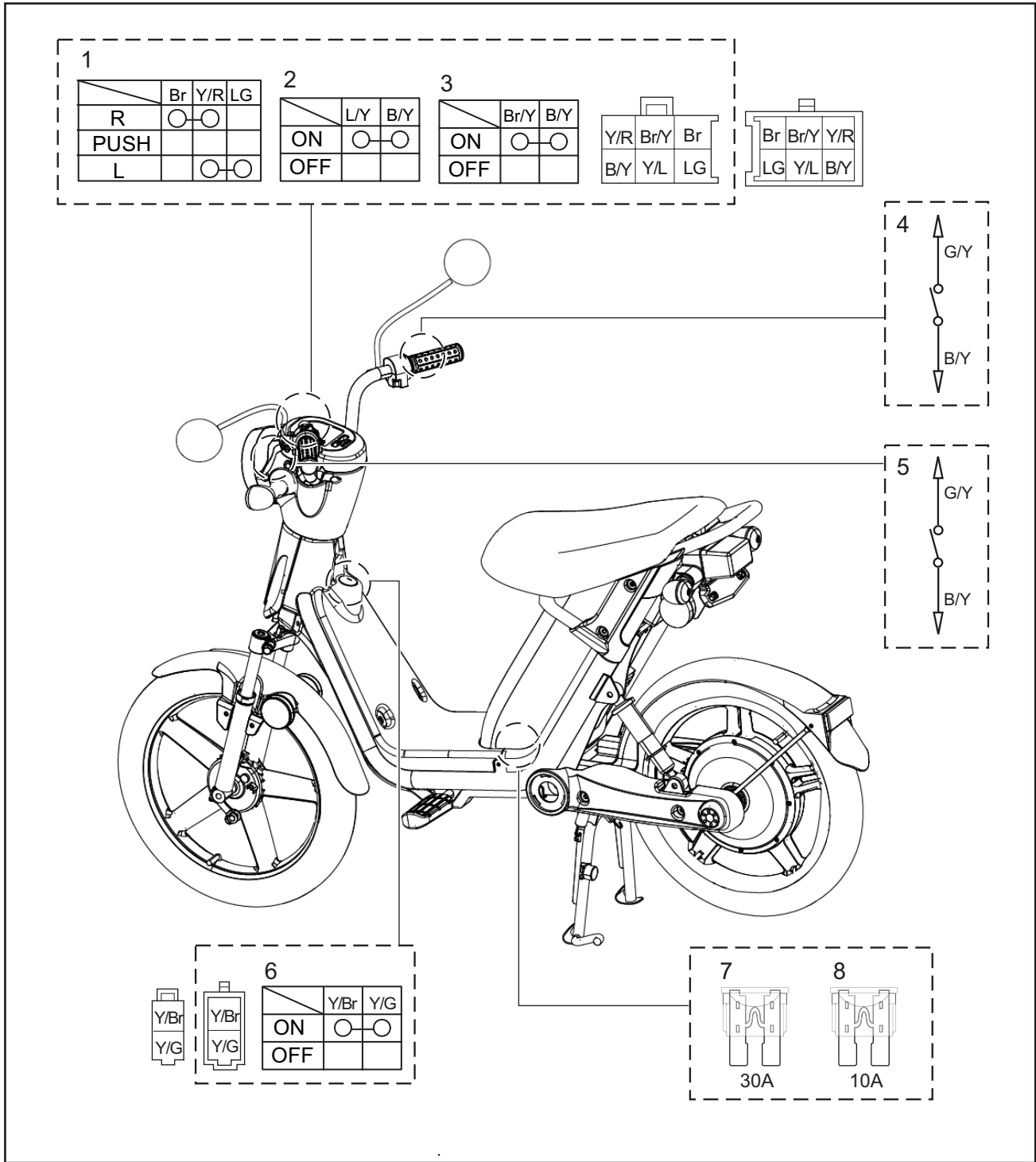

- 1 Turn signal switch
- 2 Horn switch
- 3 Headlight switch

- 4 Front brake switch
- 5 Rear brake switch
- 6 Main switch

- 7 Main fuse
- 8 Turn signal fuse

CHECKING THE BULBS AND BULB SOCKETS

Check each bulb and bulb socket for damage or wear, proper connections, and also for continuity between the terminals.

Damage/wear → Repair or replace the bulb, bulb socket or both.

Improperly connected → Properly connect.

No continuity → Repair or replace the bulb, bulb socket or both.

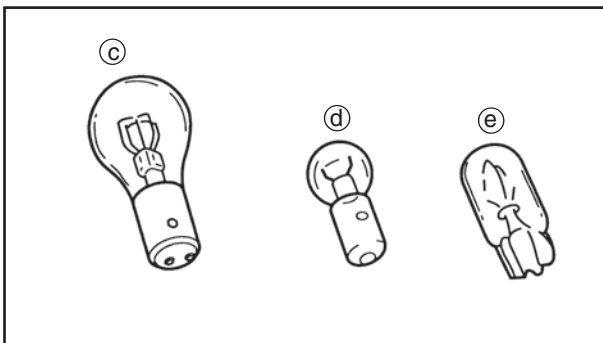
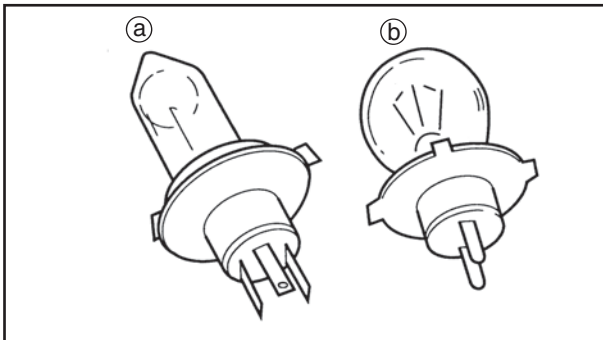

TYPES OF BULBS

The bulbs used on this scooter are shown in the illustration on the left.

- Bulbs (a) and (b) are used for the headlights and usually use a bulb holder that must be detached before removing the bulb. The majority of these types of bulbs can be removed from their respective socket by turning them counterclockwise.
- Bulb (c) is used for turn signal and tail/brake lights and can be removed from the socket by pushing and turning the bulb counterclockwise.
- Bulbs (d) and (e) are used for meter and indicator lights and can be removed from their respective socket by carefully pulling them out.

CHECKING THE CONDITION OF THE BULBS

The following procedure applies to all of the bulbs.

1. Remove:
 - bulb

⚠ WARNING

Since the headlight bulb gets extremely hot, keep flammable products and your hands away from the bulb until it has cooled down.

NOTICE

- Be sure to hold the socket firmly when removing the bulb. Never pull the lead, otherwise it may be pulled out of the terminal in the coupler.
- Avoid touching the glass part of the headlight bulb to keep it free from oil, otherwise the transparency of the glass, the life of the bulb, and the luminous flux will be adversely affected. If the headlight bulb gets soiled, thoroughly clean it with a cloth moistened with alcohol or lacquer thinner.

CHECKING THE BULBS AND BULB SOCKETS



2. Check:
 - bulb (for continuity)
(with the pocket tester)
No continuity → Replace.

TIP

Before checking for continuity, set the pocket tester to “0” and to the “ $\Omega \times 1$ ” range.

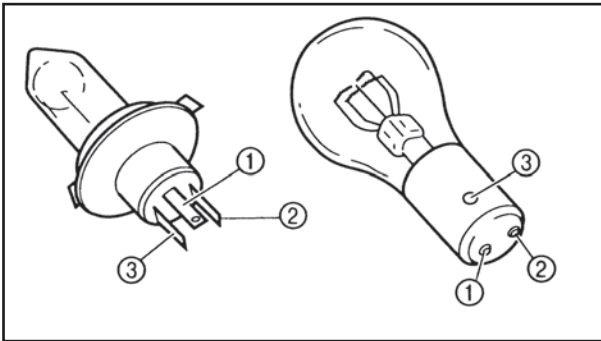

- a. Connect the positive tester probe to terminal ① and the negative tester probe to terminal ②, and check the continuity.
- b. Connect the positive tester probe to terminal ① and the negative tester probe to terminal ③, and check the continuity.
- c. If either of the readings indicate no continuity, replace the bulb.

CHECKING THE CONDITION OF THE BULB SOCKETS

The following procedure applies to all of the bulb sockets.

1. Check:
 - bulb socket (for continuity)
(with the pocket tester)
No continuity → Replace.

TIP

Check each bulb socket for continuity in the same manner as described in the bulb section; however, note the following.

- a. Install a good bulb into the bulb socket.
- b. Connect the pocket tester probes to the respective leads of the bulb socket.
- c. Check the bulb socket for continuity. If any of the readings indicate no continuity, replace the bulb socket.

LIGHTING SYSTEM



LIGHTING SYSTEM CIRCUIT DIAGRAM

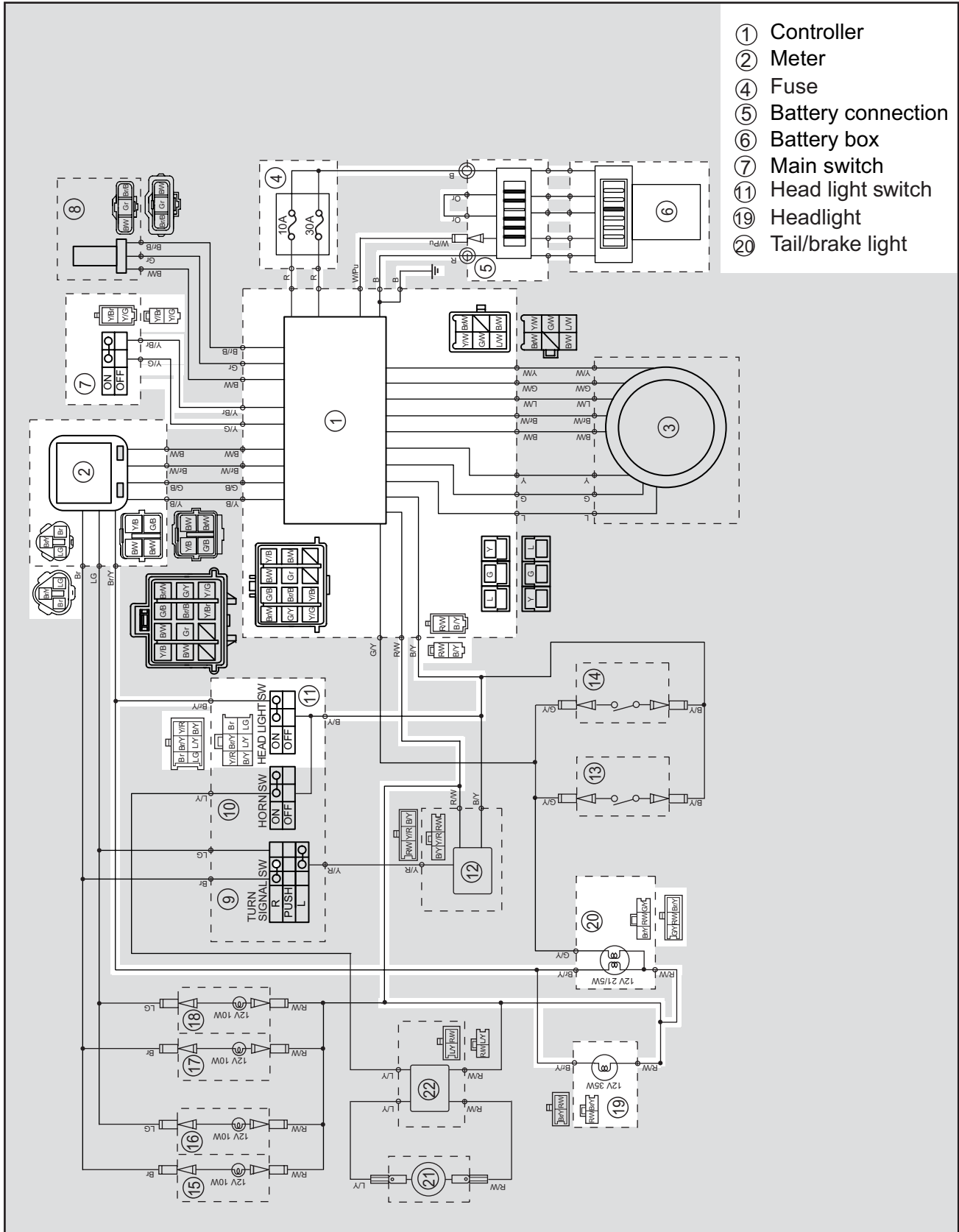

TROUBLESHOOTING

Any of the following fail to light: headlight, and meter light.

Check:

1. main fuse
2. battery
3. main switch
4. headlight switch
5. wiring connections

TIP

- Before troubleshooting, remove the following part(s):
 1. Seat
 2. Cap, front
- Troubleshoot with the pocket tester.

1. Main fuse

- Check the fuses for continuity. Refer to “CHECKING THE FUSES” in chapter 4.
- Is the fuse OK?



Replace the fuse.

2. Battery

- Check the condition of the battery. Refer to “CHECKING AND CHARGING THE BATTERY” in chapter 3.

**Minimum open-circuit voltage
40.0 V or more at 20°C**

- Is the battery OK?



• Clean the battery terminals.
• Recharge or replace the battery.

3. Main switch

- Check the main switch for continuity. Refer to “CHECKING THE SWITCHES”.
- Is the main switch OK?



Replace the main switch.

4. Headlight switch

- Check the headlight switch for continuity. Refer to “CHECKING THE SWITCHES”.
- Is the headlight switch OK?

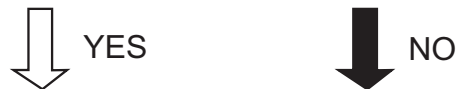

The headlight switch is faulty. Replace the left handlebar switch.

5. Wiring

- Check the entire lighting system’s wiring. Refer to “CIRCUIT DIAGRAM”.
- Is the lighting system’s wiring properly connected and without defects?



Check the condition of each of the lighting system’s circuits. Refer to “CIRCUIT DIAGRAM”.

Properly connect or repair the lighting system’s wiring.

CHECKING THE LIGHTING SYSTEM

1. The headlight fail to come on.

1. Headlight bulb and socket

- Check the headlight bulb and socket for continuity. Refer to “CHECKING THE BULBS AND BULB SOCKETS”
- Are the headlight bulb and socket OK?

↓ YES

↓ NO

Replace the headlight bulb, socket or both.

2. Voltage

- Connect the pocket tester (DC 20 V) to the headlight couplers as shown.

Positive tester probe → red/white ①
 Negative tester probe → brown/yellow ②

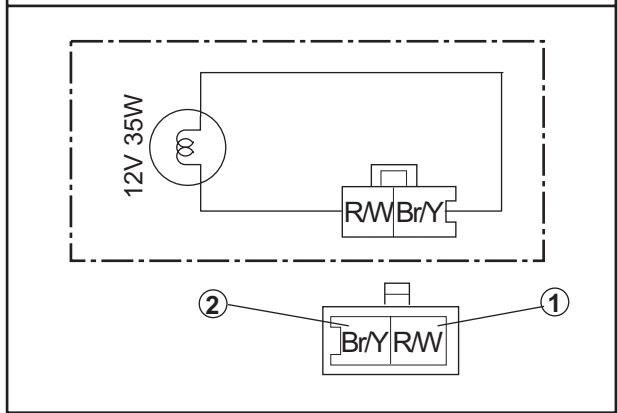

- Set the main switch to “ON”.
- Measure the voltage (DC 12 V) on the headlight coupler (wire harness side).
- Is the voltage within specification?

↓ YES

↓ NO

This circuit is OK.

Wiring circuit from the main switch to the headlight light coupler is faulty and must be repaired.

3. The tail/brake light fails to come on.

1. Tail/brake light bulb and socket

- Check the tail/brake light bulb and socket for continuity. Refer to “CHECKING THE BULBS AND BULB SOCKETS”
- Are the tail/brake light bulb and socket OK?

↓ YES

↓ NO

Replace the tail/brake light bulb, socket or both.

2. Voltage

- Connect the pocket tester (DC 20 V) to the tail/brake light coupler (wire harness side) as shown.

Positive tester probe → red/white ①
 Negative tester probe → brown/yellow ②

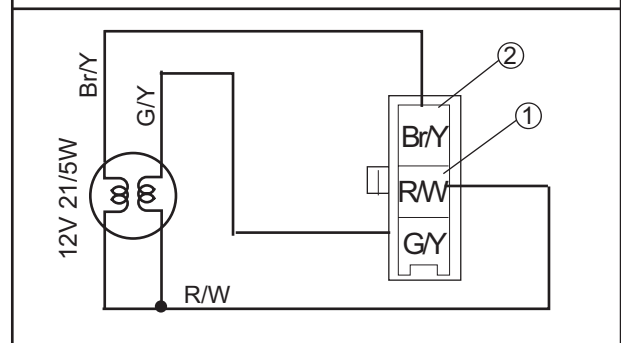

- Set the main switch to “ON”.
- Measure the voltage (DC 12V) on the tail/brake light coupler (tail/brake light side).
- Is the voltage within specification?

↓ YES

↓ NO

This circuit is OK.

Wiring circuit from the main switch to the tail/brake light coupler is faulty and must be repaired.

SIGNALING SYSTEM



SIGNALING SYSTEM CIRCUIT DIAGRAM

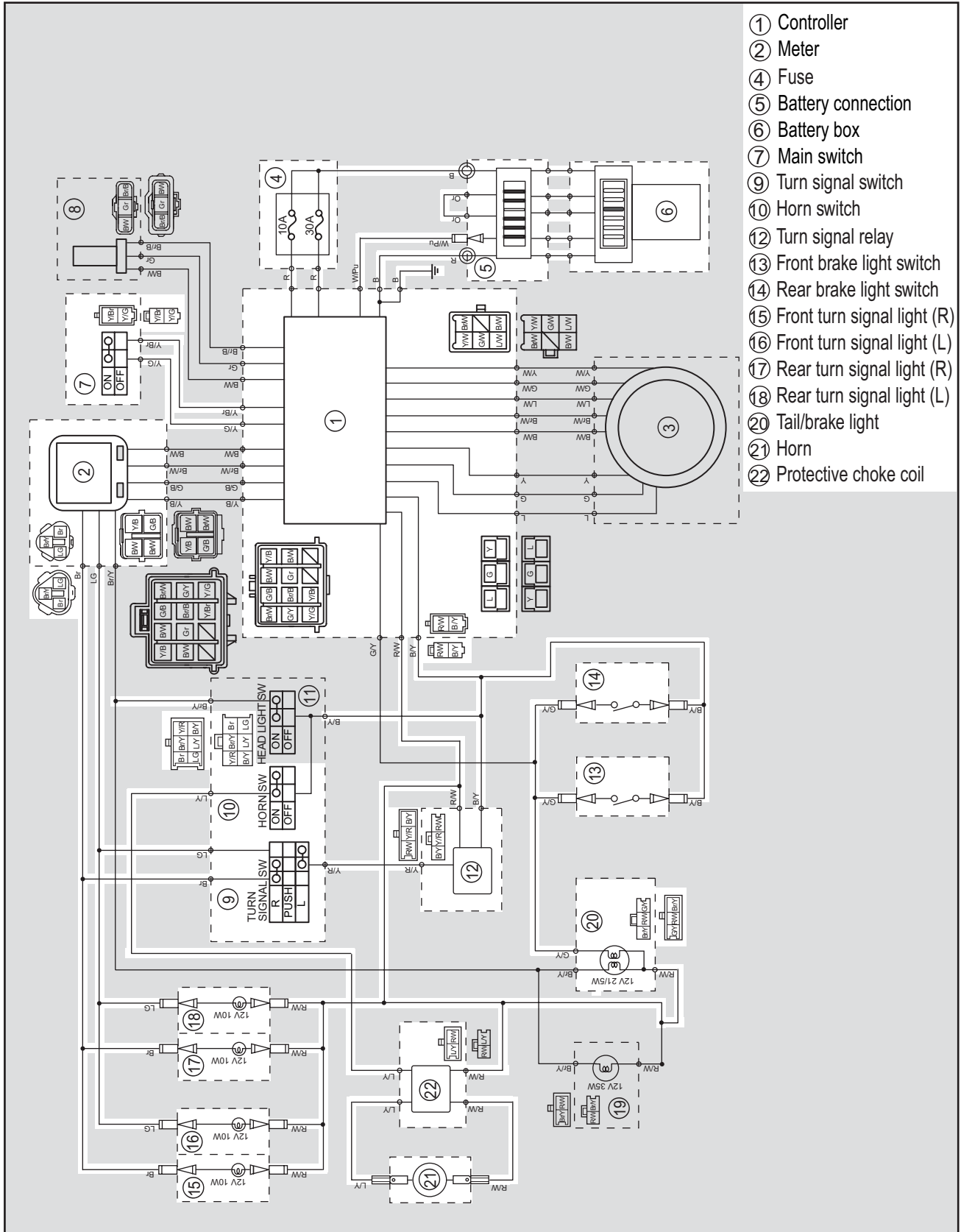

- ① Controller
- ② Meter
- ④ Fuse
- ⑤ Battery connection
- ⑥ Battery box
- ⑦ Main switch
- ⑨ Turn signal switch
- ⑩ Horn switch
- ⑫ Turn signal relay
- ⑬ Front brake light switch
- ⑭ Rear brake light switch
- ⑮ Front turn signal light (R)
- ⑯ Front turn signal light (L)
- ⑰ Rear turn signal light (R)
- ⑱ Rear turn signal light (L)
- ⑳ Tail/brake light
- ㉑ Horn
- ㉒ Protective choke coil

TROUBLESHOOTING

- Any of the following fail to light : turn signal light, brake light or an indicator light.
- The horn fails to sound.

Check:

1. main fuse
2. turn signal fuse
3. battery
4. main switch
5. turn signal switch
6. wiring connections
(of the entire signaling system)

TIP

- Before troubleshooting, remove the following part(s):
 1. Seat
 2. Cap, front
 3. Bottom cover, front
- Troubleshoot with the pocket tester.

1. Main fuse

- Check the fuse for continuity. Refer to "CHECKING THE FUSES" in chapter 4.
- Is the fuse OK?



Replace the fuse.

2. Battery

- Check the condition of the battery. Refer to "CHECKING AND CHARGING THE BATTERY" in chapter 5.

Minimum open-circuit voltage
40.0 V or more at 20°C

- Is the battery OK?



- Clean the battery terminals.

- Recharge or replace the battery.

3. Main switch

- Check the main switch for continuity. Refer to "CHECKING THE SWITCHES".
- Is the main switch OK?



Replace the main switch.

4. Wiring

- Check the entire signal system's wiring. Refer to "CIRCUIT DIAGRAM".
- Is the signaling system's wiring properly connected and without defects?



Check the condition of each of the signaling system's circuits. Refer to "CHECKING THE SIGNALING SYSTEM".

Properly connect or repair the signaling system's wiring.

CHECKING THE SIGNALING SYSTEM

1. The horn fails to sound.

1. Horn switch

- Check the horn switch for continuity. Refer to “CHECKING THE SWITCHES”.
- Is the horn switch OK?



Replace the left handlebar switch.

2. Voltage

- Connect the pocket tester (DC 20 V) to the horn connector at the horn terminal as shown.

Positive tester probe → red/white ①
Negative tester probe → ground

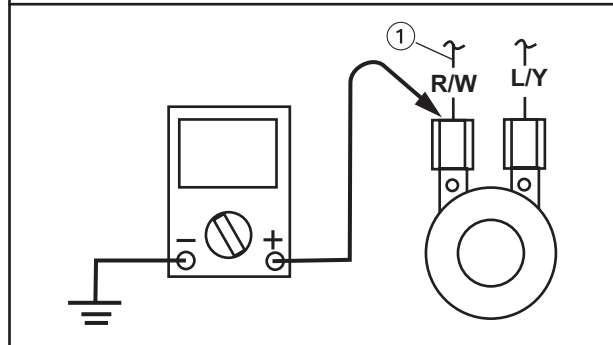

- Set the main switch to “ON”.
- Measure the voltage (DC 12 V) of brown at the horn terminal.
- Is the voltage within specification?



The wiring circuit from the main switch to the horn connector is faulty and must be repaired.

3. Horn

- Disconnect the blue/yellow connector at the horn terminal.
- Connect a jumper lead ① to the horn terminal and ground the jumper lead.
- Set the main switch to “ON”.
- Does the horn sound?

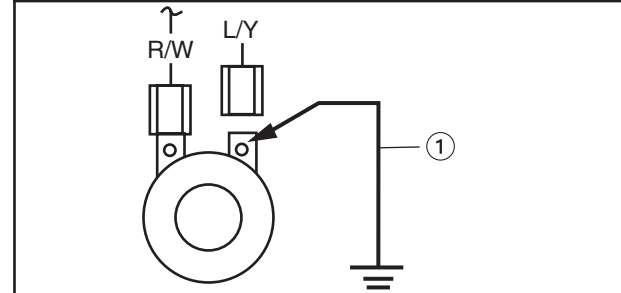

Replace the horn.

4. Voltage

- Connect the pocket tester (DC 20 V) to the horn connectors as shown.

Positive tester probe → red/white ①
Negative tester probe → ground

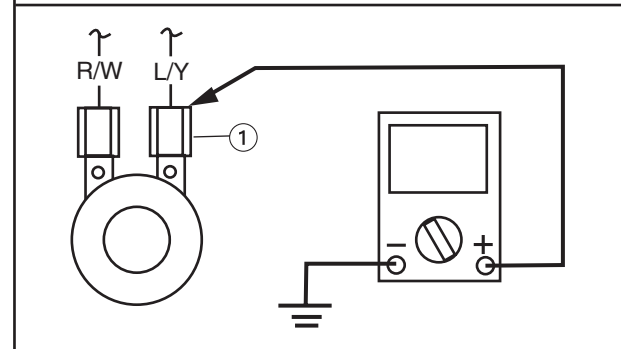

- Set the main switch to “ON”. Push horn switch
- Measure the voltage (DC 12V) of blue/yellow ① at the horn terminal.
- Is the voltage within specification?



This circuit is OK.

The wiring circuit or horn switch is faulty and must be repaired.

SIGNALING SYSTEM



2. The tail/brake light fails to come on.

1. Tail/brake light bulb and socket

- Check the tail/brake light bulb and socket for continuity. Refer to "CHECKING THE BULBS AND BULB SOCKETS"
- Are the tail/brake light bulb and socket OK?

↓ YES ↓ NO

Replace the tail/brake light bulb, socket or both.

2. Brake light switches

- Check the brake light switches for continuity. Refer to "CHECKING THE SWITCHES".
- Is the brake light switch OK?

↓ YES ↓ NO

Replace the brake light switch.

3. Voltage

- Connect the pocket tester (DC 20 V) to the tail/brake light coupler (wire harness side) as shown.

Positive tester probe → red/white ①
Negative tester probe → green/yellow ②

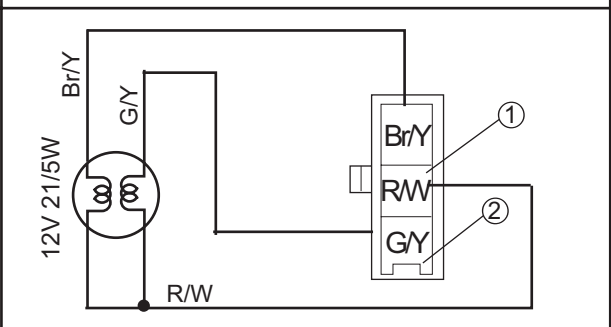

- Set the main switch to "ON".
- Pull in the brake levers.
- Measure the voltage (DC 1 2V) of red/white ① on the tail/brake light coupler (wire harness side).
- Is the voltage within specification?

↓ YES ↓ NO

This circuit is OK.

The wiring circuit from the main switch to the tail/brake light coupler is faulty and must be repaired.

3. The turn signal light, turn signal indicator light or both fail to blink.

1. Turn signal indicator light bulb and socket

- Check the turn signal light bulb and socket for continuity. Refer to "CHECKING THE BULBS AND BULB SOCKETS"
- Are the turn signal light bulb and socket OK?

↓ YES ↓ NO

Replace the turn signal light bulb, socket or both.

2. Turn signal switch

- Check the turn signal switch for continuity. Refer to "CHECKING THE SWITCHES".
- Is the turn signal switch OK?

↓ YES ↓ NO

Replace the left handlebar switch.

3. Voltage

- Connect the pocket tester (DC 20 V) to the turn signal relay coupler (wire harness side) as shown.

Positive tester probe → red/white ①
Negative tester probe → ground

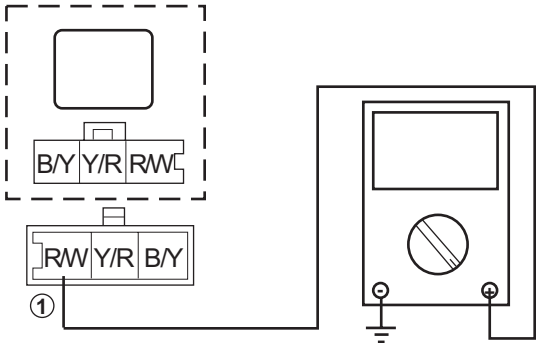

- Set the main switch to "ON".
- Measure the voltage (DC 12 V) on red/white ① at the turn signal relay coupler (wire harness side).
- Is the voltage within specification?

↓ YES ↓ NO

The wiring circuit from the main switch to the turn signal relay coupler is faulty and must be repaired.

4. Voltage

- Connect the pocket tester (DC 20 V) to the turn signal relay coupler (wire harness side) as shown.

Positive tester probe → yellow/red ①
Negative tester probe → ground

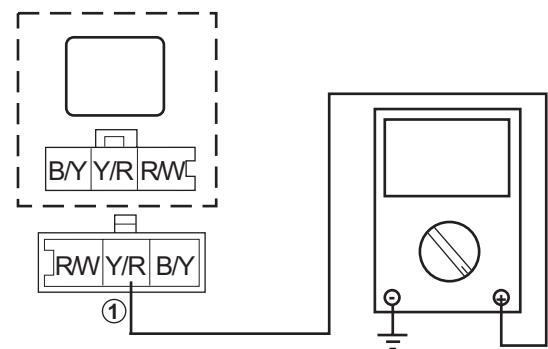

- Set the main switch to "ON".
- Set the turn signal switch to "L" or "R".
- Measure the voltage (DC 12 V) on yellow/red ① at the turn signal relay coupler (wire harness side).
- Is the voltage within specification?

↓ YES ↓ NO

The turn signal relay is faulty and must be replaced.

5. Voltage

- Connect the pocket tester (DC 20 V) to the turn signal light connector or meter coupler (wire harness side) as shown.

Right turn signal light
Positive tester probe → red/white ①
Negative tester probe → brown ③

Left turn signal light
Positive tester probe → red/white ①
Negative tester probe → light green ②

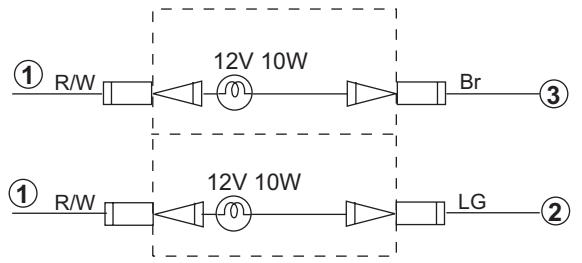

- Set the main switch to "ON".
- Set the turn signal switch to "L" or "R".
- Measure the voltage (DC 12 V) of the light green ② or brown ③ at the turn signal light connector (wire harness side).
- Is the voltage within specification?

↓ YES ↓ NO

This circuit is OK. The wiring circuit from the turn signal switch to the turn signal light connector is faulty and must be repaired.

CHAPTER 7

CHASSIS

FRONT WHEEL / REAR WHEEL	7-1
FRONT WHEEL	7-1
REAR WHEEL	7-2
REMOVING THE FRONT/ REAR WHEEL	7-3
CHECKING THE FRONT/ REAR WHEEL	7-3
CHECKING THE FRONT/ REAR WHEEL AXLE	7-3
ASSEMBLE THE FRONT/ REAR WHEEL	7-4
INSTALL THE FRONT/ REAR WHEEL	7-4
FRONT BRAKE / REAR BRAKE	7-5
FRONT BRAKE	7-5
REAR BRAKE	7-6
REMOVING THE FRONT/ REAR BRAKE	7-7
CHECKING THE BRAKE DISK	7-7
CHECKING THE BRAKE SHOES	7-7
CHECKING THE BRAKE DRUMS	7-8
REMOVING THE FRONT/ REAR BRAKE	7-8
SWINGARM	7-10
SWINGARM	7-10
REMOVE THE SWINGARM	7-11
CHECKING THE SWINGARM	7-11
REAR SHOCK ABSORBER	7-12
REAR SHOCK ABSORBER	7-12
CHECKING THE REAR SHOCK ABSORBER	7-13
INSTALL THE REAR SHOCK ABSORBER	7-13
STEERING SYSTEM	7-14
HANDLEBAR	7-14
REMOVING THE HANDLEBAR GRIP	7-15
INSTALLING THE HANDLEBAR	7-15

CHAPTER 7

CHASSIS

LOWER BRACKET	7-17
LOWER BRACKET.....	7-17
REMOVING THE LOWER BRACKET.....	7-18
CHECKING THE LOWER BRACKET	7-18
INSTALLING THE LOWER BRACKET	7-19
FRONT FORK	7-21
FRONT FORK	7-21
REMOVING THE FRONT FORK	7-22
DISASSEMBLE THE FRONT FORK	7-22
CHECKING THE FRONT FORK	7-23
ASSEMBLING THE FRONT FORK	7-23
INSTALLING THE FRONT FORK	7-24

FRONT WHEEL

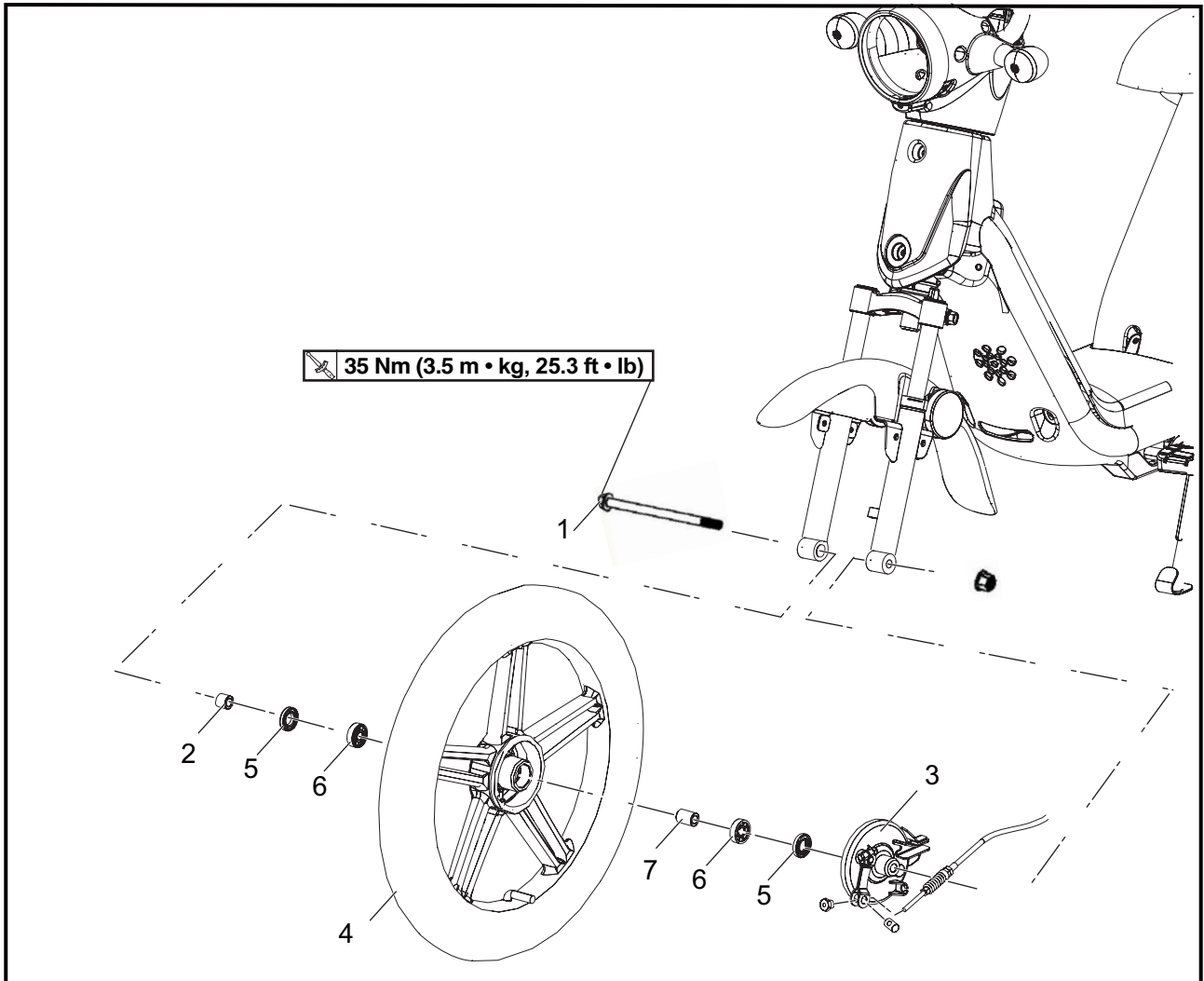

Order	Job/Part	Q'ty	Remarks
	Removing the front wheel		Remove the parts in the order listed.
1	Hexagon flange bolt	1	<p>TIP _____</p> <p>Place the scooter on a suitable stand so that the front wheel is elevated.</p> <p>_____</p> <p>For installation, reverse the removal procedure.</p>
2	Collar B	1	
3	Front brake shoe plate	1	
4	Front wheel	1	
5	Oil seal	2	
6	Bearing	2	
7	Collar A	1	

REAR WHEEL

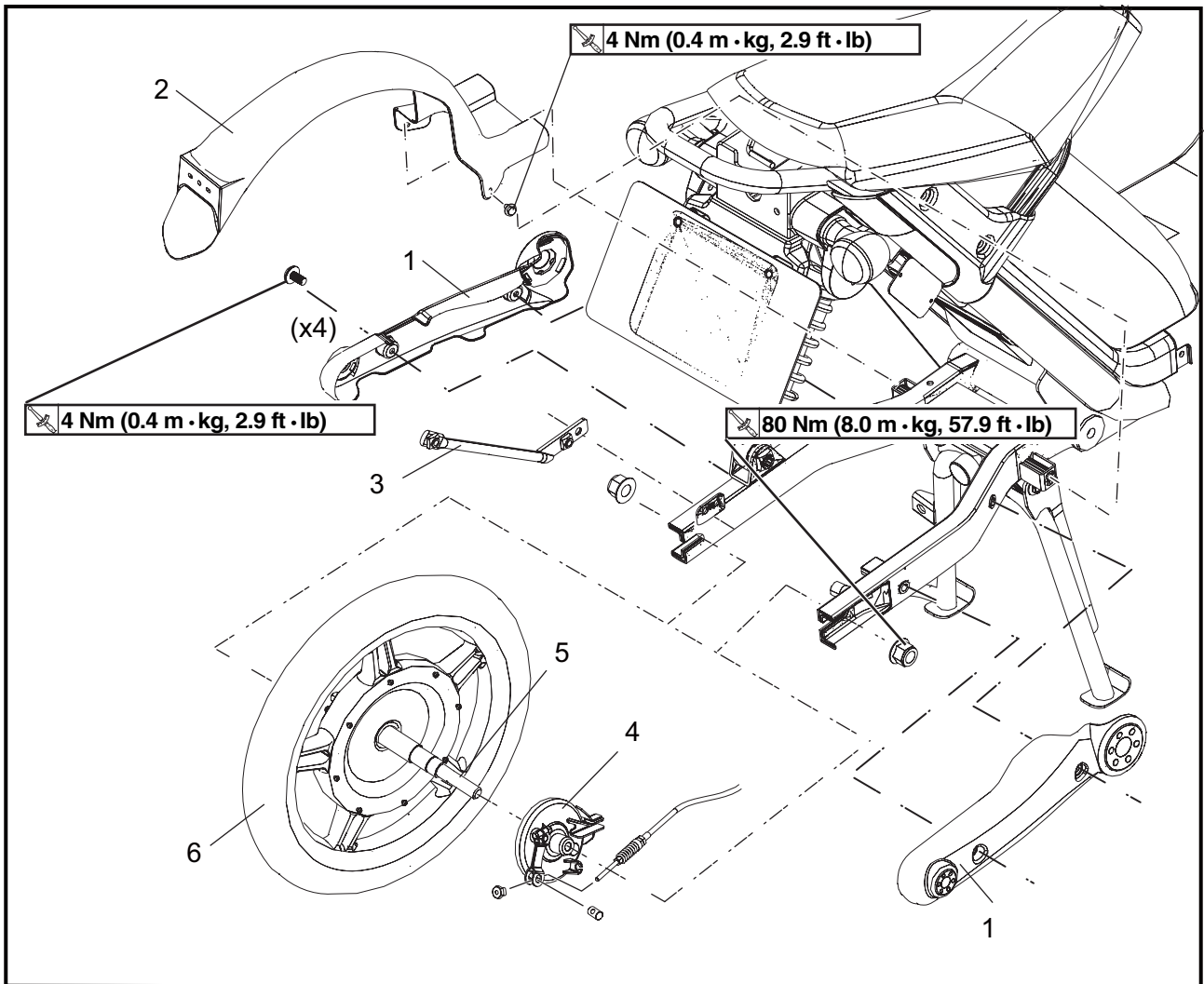

Order	Job/Part	Q'ty	Remarks
	Removing the rear wheel		Remove the parts in the order listed. TIP _____ Place the scooter on a suitable stand so that the front wheel is elevated. _____
1	Rear bottom cover L/R	1/1	
2	Rear fender	1	
3	Rear fender bracket	1	
4	Rear brake shoe plate	1	
5	Hexagon flange bolt	1	
6	Rear wheel	1	
			For installation, reverse the removal procedure.

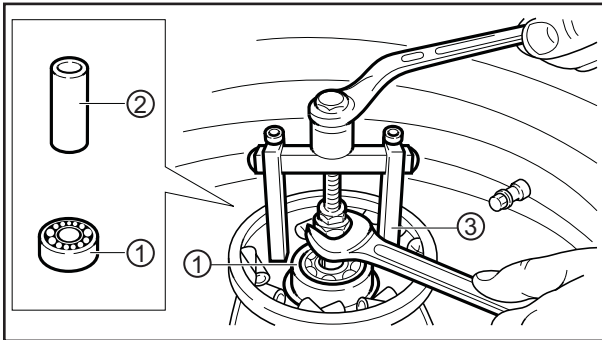

REMOVING THE FRONT/ REAR WHEEL

1. Removing

- Wheel bearings ①
- Collar ②

Remove the wheel bearings with a general bearing puller ③ .



General bearing puller
SA6100-A26-0FA1

NOTICE

Securely support the wheel to avoid damaging the brake disk. If the brake disk had damaged, please replace immediately.

CHECKING THE FRONT/ REAR WHEEL

1. Checking

- Wheels
Out of shape → replace.
- Rim
Out of shape → replace the wheel or check the bearings operation.
- Tire
Damage/wear → Replace.
Please refer to “CHECKING THE TIRES” in chapter 3.

⚠ WARNING

Ride conservatively after installing a tire to allow it to seat itself properly on the rim.

CHECKING THE FRONT/ REAR WHEEL AXLE

1. Checking

- Front wheel axle ①
- Rear wheel axle ②
Damage/wear → Replace.
Roll the wheel axle on a flat surface and check.

⚠ WARNING

Do not attempt to straighten a bent wheel axle.

- Front/ rear wheel axle
If the wheel axle could shake or the tire unsmooth operation → replace the wheel bearings.

NOTICE

- **Do not strike the center race of the bearings to avoid damaging the bearings.**
- **Securely support the wheel to avoid damaging the brake disk. If the brake disk had damaged, please replace immediately.**

- Oil seal
Damage/wear → Replace.

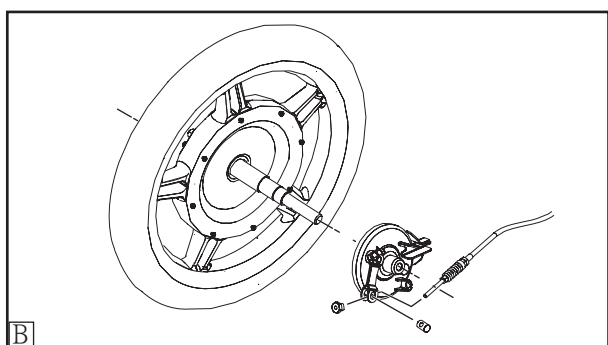
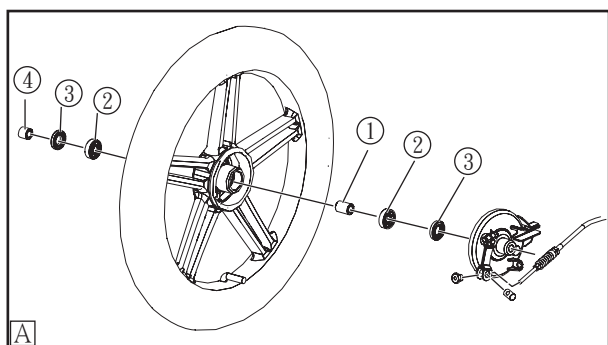

ASSEMBLE THE FRONT/ REAR WHEEL

1. Install
 - Collar A ①
 - Bearing ②
 - Oil seal ③
 - Collar B ④
 - Front brake shoe plate

TIP

- Put lithium soap base grease on the bearings and oil seal lips when installing.
- Using the collar connect outside track of the bearing while installing.
- Replacing the oil seal should use a new one.
- Install oil seal with their manufacturer brands or numbers facing outwards.

- Ⓐ Install the front wheel
- Ⓑ Install the rear wheel

INSTALL THE FRONT/ REAR WHEEL

For installation, reverse the removal procedure and following procedure applies to all the front/ rear wheel.

1. Lubricate
 - Front wheel axle
 - Wheel bearings
 - Oil seal lips

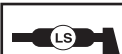

Lithium-soap-based grease

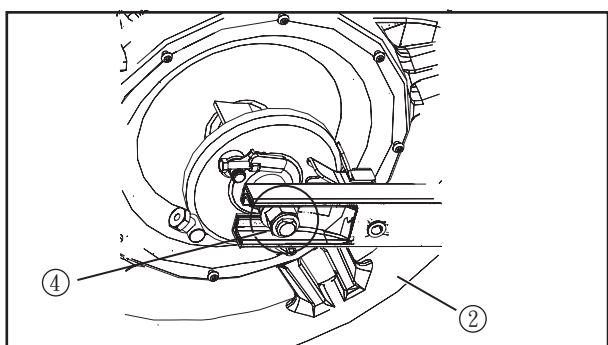
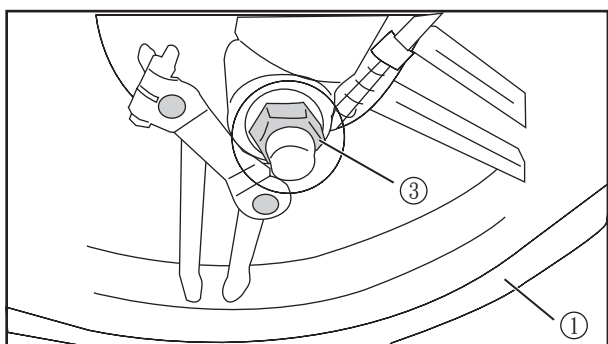

2. Install
 - Front wheel ①
 - Rear wheel ②
3. Tighten
 - Front wheel axle ③
 - Front wheel axle nut

	35 Nm (3.5 m•kg, 25.3 ft•lb)
---	------------------------------
 - Rear wheel axle ④
 - Rear wheel axle nut

	80 Nm (8.0 m•kg, 57.9 ft•lb)
---	------------------------------

NOTICE

Before tightening the wheel axle nut, push down hard on the handlebar several times and check if the front fork rebounds smoothly.

⚠ WARNING

Make sure the brake cable is routed properly.

FRONT BRAKE

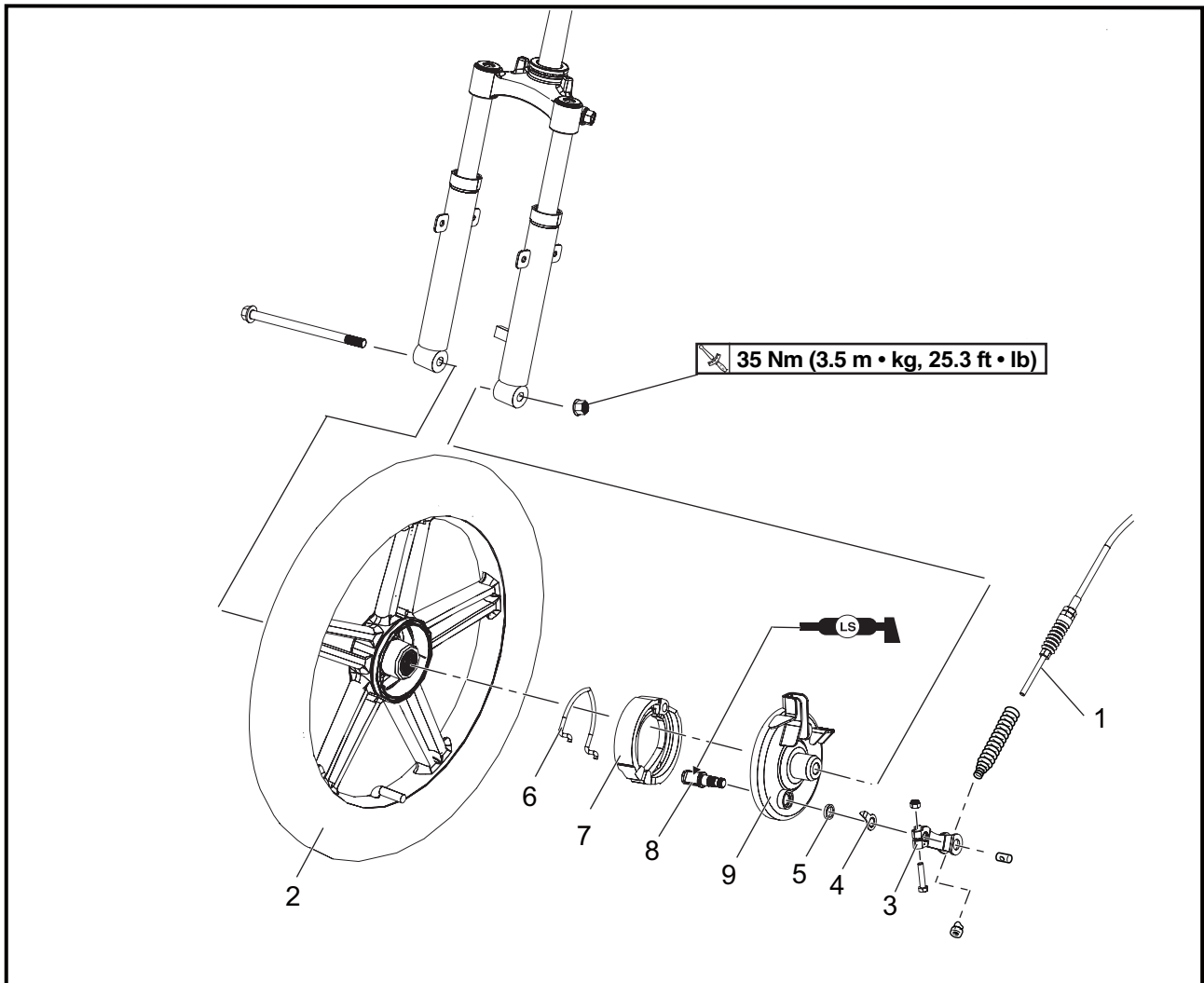

Order	Job/Part	Q'ty	Remarks
	Removing the front brake		Remove the parts in the order listed. Please refer to " LOWER BRACKET " in cheaper 7. For installation, reverse the removal procedure.
	Front fender		
1	Front brake cable	1	
2	Front wheel	1	
3	Brake arm	1	
4	Brake indicator	1	
5	Felt seal	1	
6	Spring	1	
7	Brake shoe	2	
8	Brake arm cam	1	
9	Brake disk A	1	

REAR BRAKE

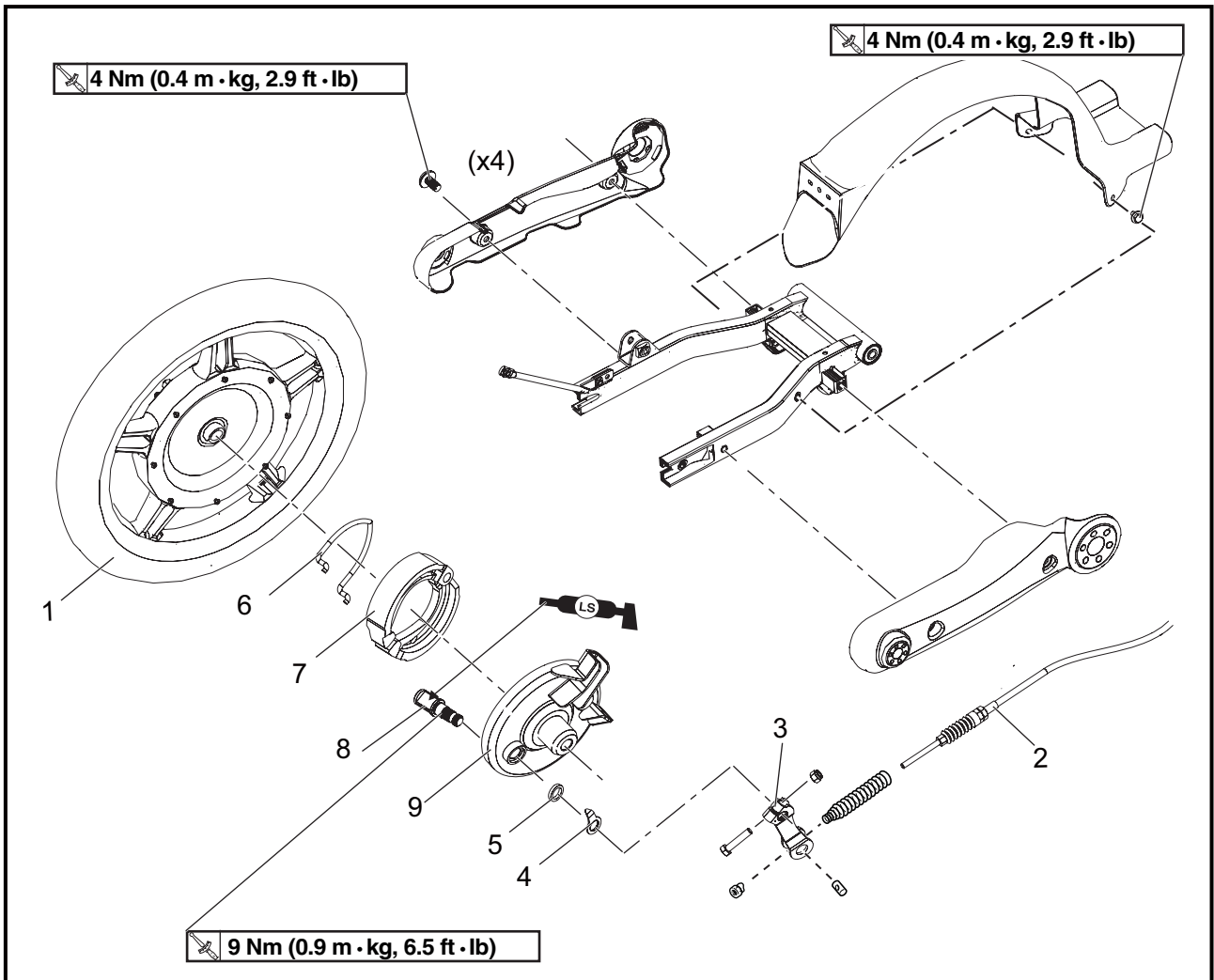

Order	Job/Part	Q'ty	Remarks
	Removing the rear brake		Remove the parts in the order listed.
	Front fender		Please refer to " MOVING AND STALLING THE COVER " in cheaper 3.
	Bottom cover of rear fork (L/ R)		
1	Rear wheel	1	
2	Rear brake cable	1	
3	Brake arm	1	
4	Brake indicator	1	
5	Felt seal	1	
6	Spring	1	
7	Brake shoe	2	
8	Brake arm cam	1	
9	Brake disk B	1	
			For installation, reverse the removal procedure.

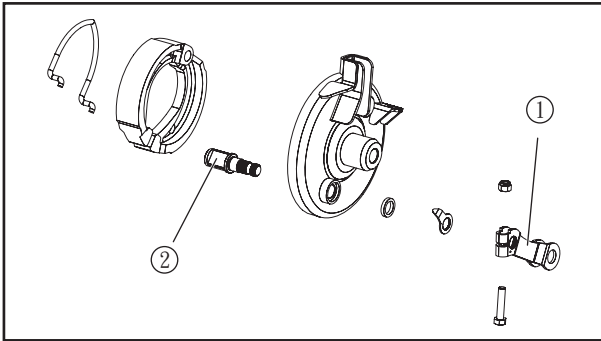

REMOVING THE FRONT/ REAR BRAKE

The following procedure applies to each brake and rear brake.

1. Removing
 - Brake arm ①
 - Brake arm cam ②

TIP

When removing the brake arm, mark the position on the brake arm where it is aligned with the punch mark in the brake arm cam.

CHECKING THE BRAKE DISK

The following procedure applies to each brake.

1. Checking
 - Brake disk A
 - pivot pin
 - Brake arm cam
 - Bends/ cracks/ damage → replace.
 - Felt seal
 - Wear/ damage → replace.

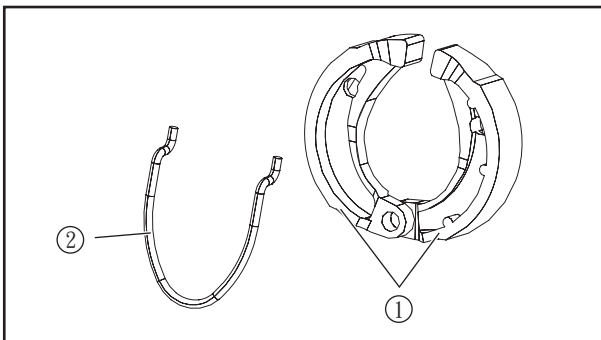

CHECKING THE BRAKE SHOES

The following procedure applies to each brake.

1. Checking
 - Brake shoes ①
 - Brake shoe spring ②
 - Cracks/ damage → replace.

TIP

When replacing the brake shoes, replace the brake shoe springs at the same time.

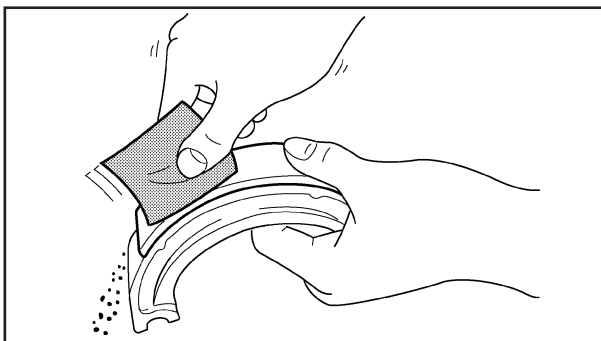

- brake shoe lining surface
 - Glazed areas → remove.
 - Use coarse sandpaper.

TIP

After using sandpaper, wipe off the polished particles with a cloth.

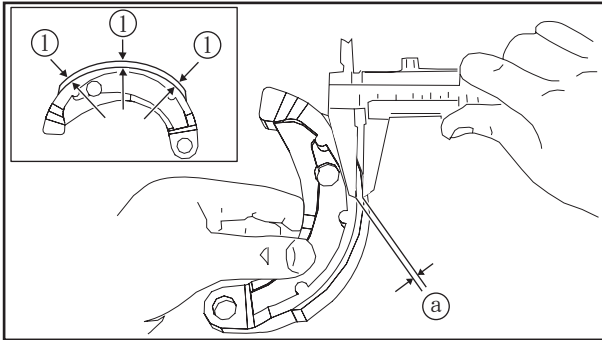

3. Measure

- brake shoe lining thickness @
- Out of specification → replace.
- ① Measuring points

TIP

Replace the brake shoes as a set if either is found to be worn to the wear limit.



Brake lining thickness
3.0 mm (0.12 in)
<Limit>: 1.5 mm (0.06 in)

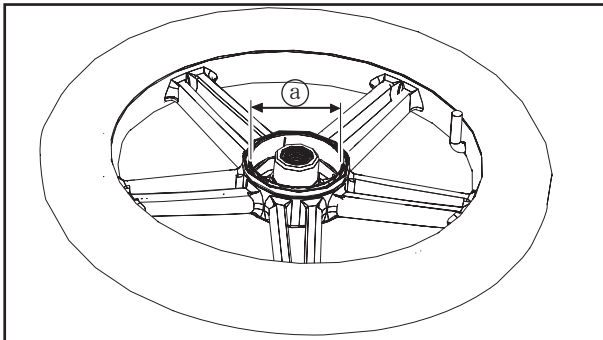

CHECKING THE BRAKE DRUMS

The following procedure applies to each brake.

1. Check

- brake drum inside diameter @
- Out of specification → replace.



Brake drum inside diameter
85.0 mm (3.35 in)
<Limit>: 86.0 mm (3.39 in)

INSTALLING THE FRONT AND THE REAR BRAKES

Reverse the "Removal" procedure.
 Note the following points.

1. Lubricate

- brake camshaft
- pivot pin

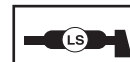

Lithium-soap-based grease

NOTICE

During installation, lightly grease the brake camshaft and the pivot pin. Wipe off the excess grease.

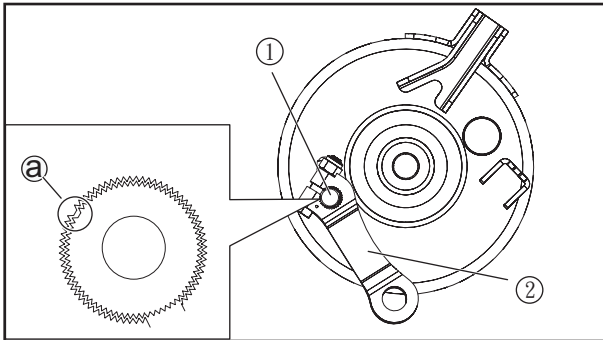

2. Install

- brake arm cam ①
- brake arm ②

 9 Nm(0.9 m•kg, 6.5ft•lb)

TIP

- Install the brake arm cam so its punch mark ① is positioned as shown.
- Align the punch mark in the brake arm cam with the mark on the brake arm.

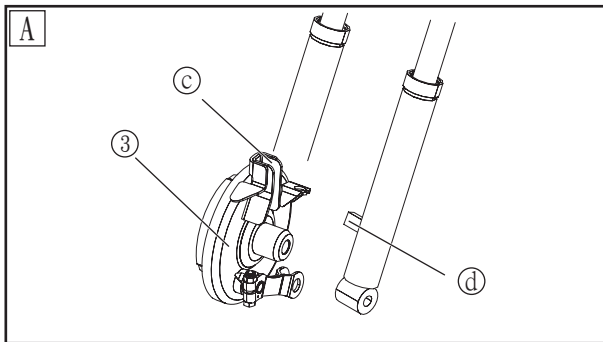

- Brake disk ③
- Rear brake cable
- brake arm operation
Unsmooth operation → repair

TIP

- When installing the brake disk, align the groove ③ of the brake disk with the projection of ④ the steering knuckle.
- Check that the brake shoes are properly positioned.

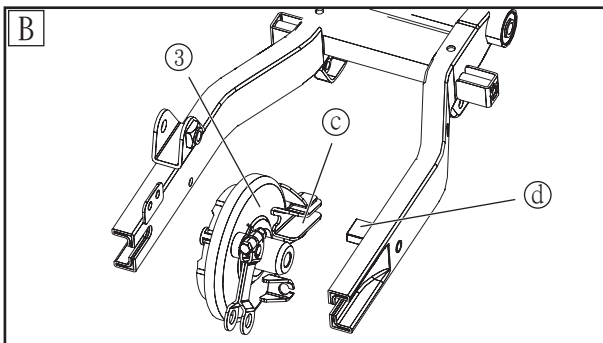

A Front fork.

B Swing arm.

3. Adjust

- front brake
- rear brake

Refer to “ADJUSTING THE FRONT BRAKE REAR BRAKE” in chapter 3.

SWINGARM



SWINGARM

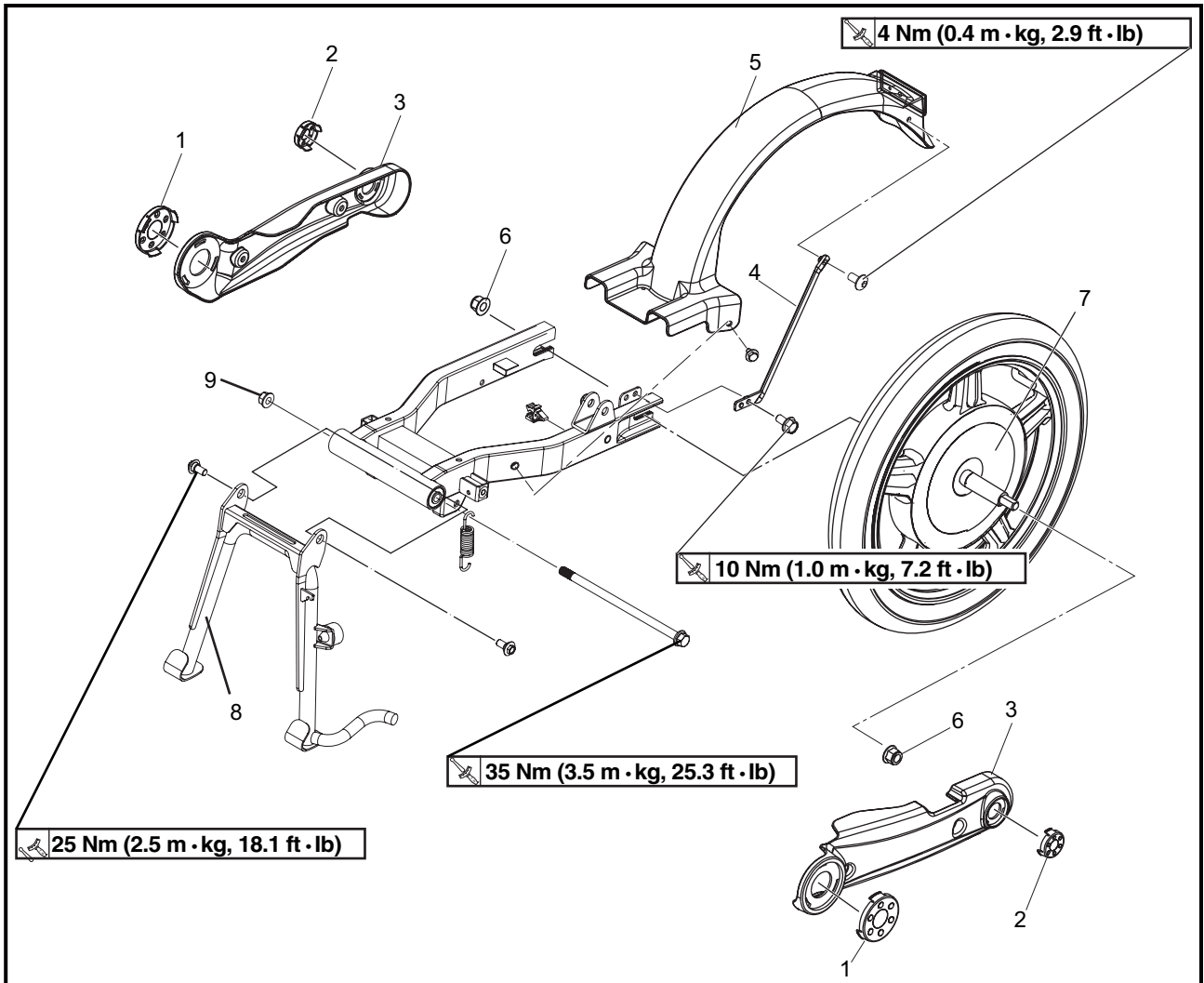

Order	Job/Part	Q'ty	Remarks
	Removing the swingarm		Remove the parts in the order listed.
1	Cap A	2	
2	Cap B	2	
3	Rear bottom cover L/R	1/1	
4	Rear fender bracket	1	
5	Rear fender	1	
6	Hexagon flange nut	2	
7	Motor	1	Removing 6 pin connector and rear brake cable before remove motor. Refer to "REAR SHOCK ABSORBER" in chapter 7.
8	Main stand	1	
9	Hexagon flange nut	1	

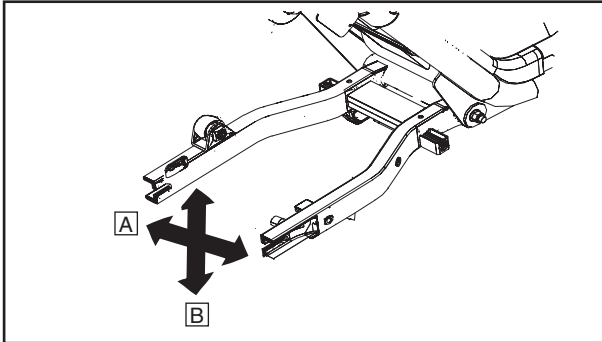

REMOVE THE SWINGARM

1. Check
 - Swing arm free play
 - a. Check the tightening torque of the pivot shaft nut.  35 Nm (3.5m •kg, 25.3ft •lb)



Swingarm free play
1.0 mm (0.04 in)

- b. Check the swingarm side play **A** by moving it from side to side. If side play is noticeable, check the spacer, bearings and frame pivot.
 - c. Check the swingarm vertical movement **B** by moving it up and down. If vertical movement is tight or rough, or if there is binding, check the spacer, bearings and frame pivot.
2. Remove
 - Pivot shaft nut
 - Pivot shaft
 - Swingarm

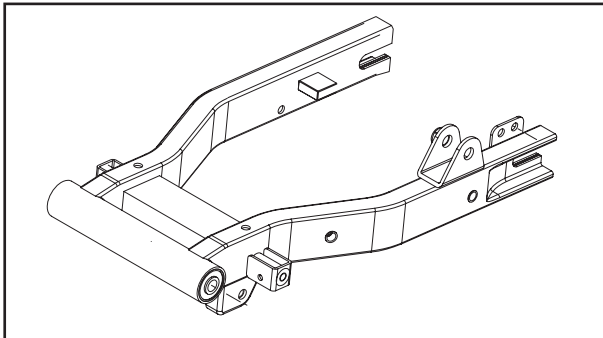

CHECKING THE SWINGARM

1. Check
 - Swingarm
Bends/cracks/damage → replace.
2. Check
 - Pivot shaft
Roll the axle on a flat surface.
Bends → replace.



Do not attempt to straighten a bent pivot shaft.

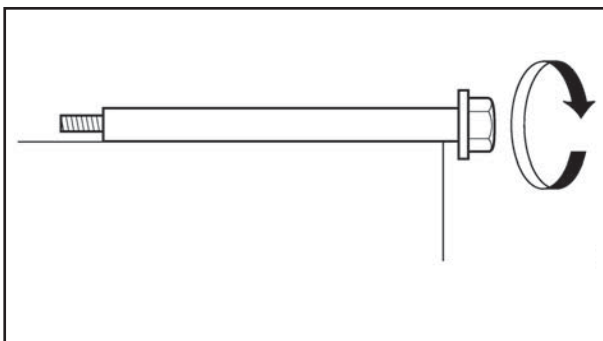

3. Clean
 - Pivot shaft
 - Spacer



Recommended cleaning solvent
Kerosene

REAR SHOCK ABSORBER



REAR SHOCK ABSORBER

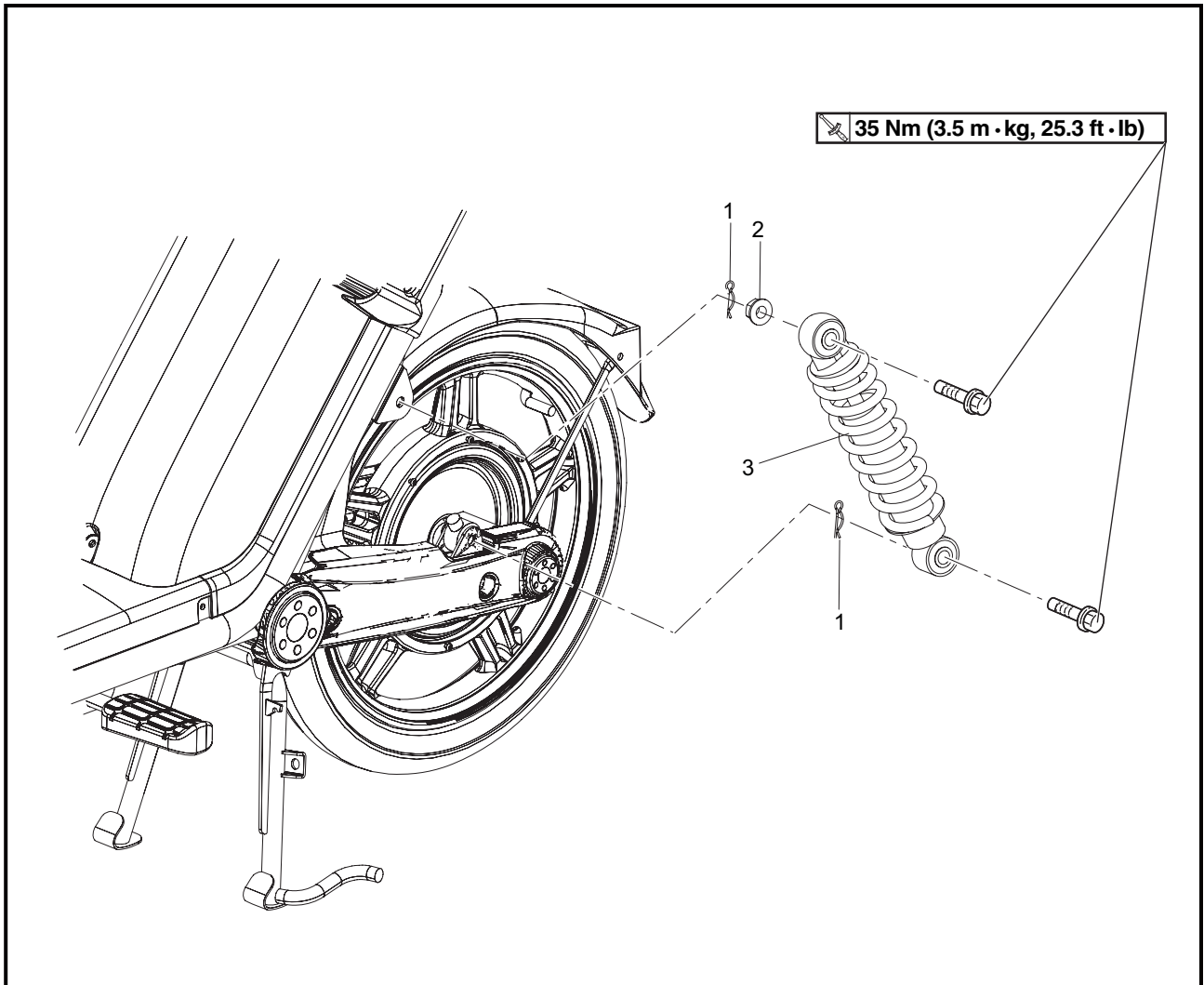

Order	Job/Part	Q'ty	Remarks
	Removing the rear shock absorber		Remove the parts in the order listed.
1	Pin	2	
2	Hexagon flange nut	1	
3	Rear shock absorber	1	
			For installation, reverse the removal procedure.

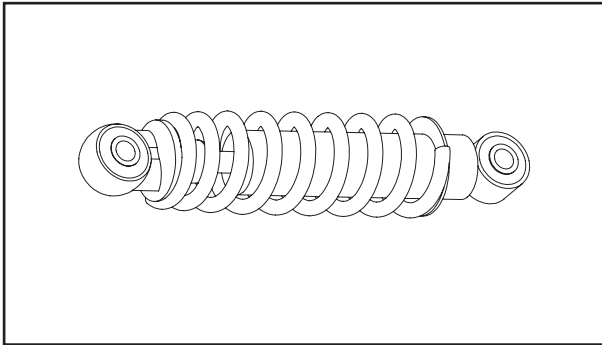

REAR SHOCK ABSORBER



CHECKING THE REAR SHOCK ABSORBER

1. Check
 - Shock absorber rod
 - Bends/damage → replace the rear absorber assembly.
 - Shock absorber
 - Oil leaks → replace the rear absorber assembly.
 - Spring
 - Fatigue → replace the rear shock absorber assembly.

INSTALL THE REAR SHOCK ABSORBER

1. Install
 - Shock absorber
 - Rear shock absorber upper bolt and nut
 -  35 Nm (3.5 m•kg, 25.3 ft•lb)
 - Rear shock absorber upper pin
 - Rear shock absorber lower bolt
 -  35 Nm (3.5 m•kg, 25.3 ft•lb)
 - Rear shock absorber lower pin

TIP

When installing the rear shock absorber assembly, press backward the vehicle slightly.

HEADLEBAR

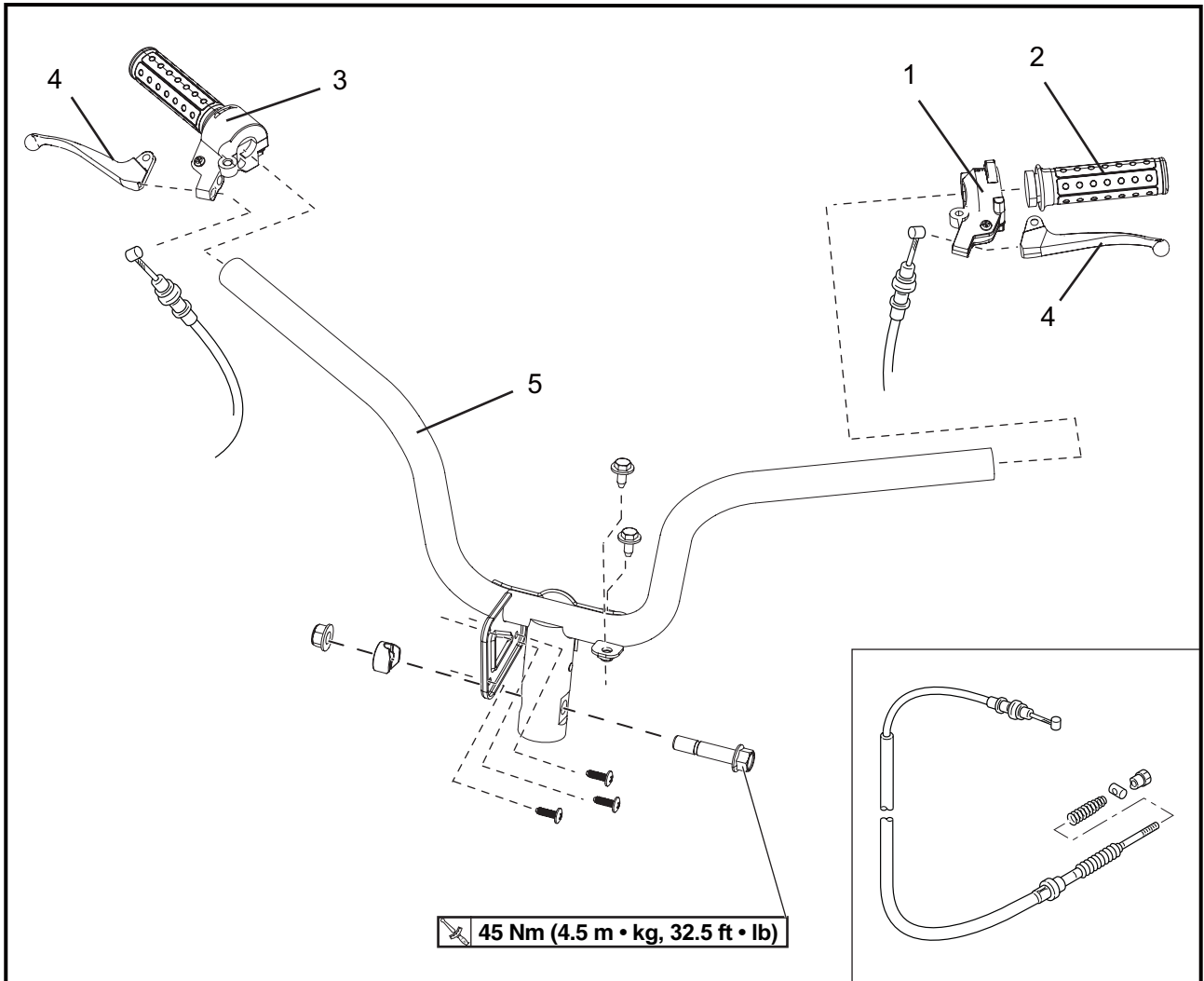

Order	Job/Part	Q'ty	Remarks
	Front brake cable Front cap Meter side L/ R Headlight Meter		Remove the parts in the order listed. Refer to "MOVING AND INSTALLING COVER " in chapter 3.
1	Handle lever assembly (L)	1	
2	Handlebar grip (L)	1	
3	Handle lever comp (R)	1	
4	Left / right brake lever	1/1	
5	Handlebar	1	
			For installation, reverse the removal procedure.

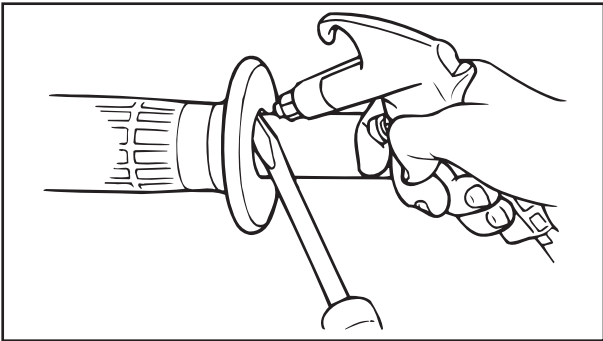

REMOVING THE HANDLEBAR GRIP

1. Remove
 - Handlebar grip

Removing step :

- Blow compressed air between the handlebar and handlebar grip, and gradually push the grip off the handlebar.

CHECKING THE HANDLEBAR

1. Check
 - HandlebarBends/ damage → replace.

! WARNING

Do not attempt to straighten a bent handlebar as this may dangerously weaken the handlebar.

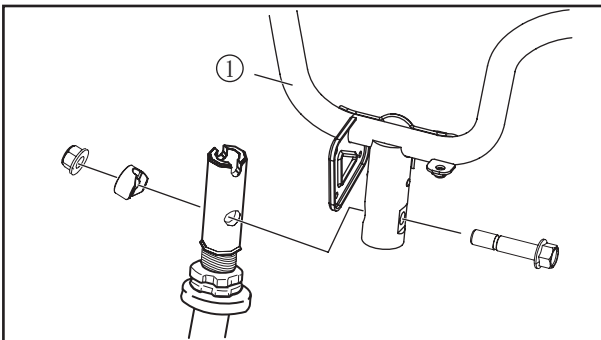

INSTALLING THE HANDLEBAR

1. Handlebar ①
Tighten the bolt.

 45 Nm (4.5 m•kg, 32.5 ft•lb)

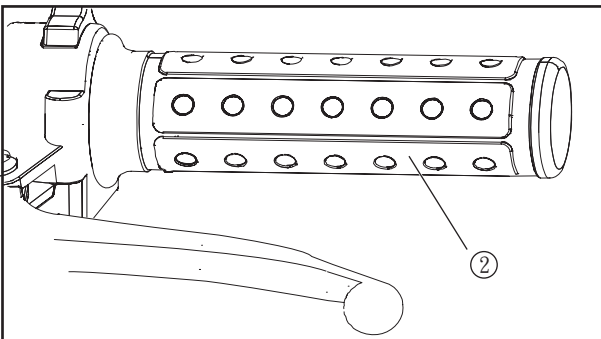

2. Install
 - Handlebar grip ②Refer to "MAINTAINENCE FRONT BRAKE" in cheaper 3.

TIP

Before installing the handlebar grip, should be put oil on the left handlebar grip.

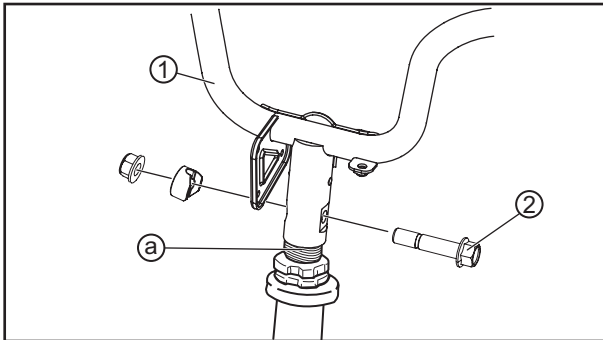

INSTALL THE HANDLEBAR

Reverse the removal procedure for installation and pay attention the following tips:

1. Clean

- If the connection part of steering (a) touch with grease, should be clean.

! WARNING

- Install all cables should refer to "CABLE ROUTING" in chapter 2.
- Securely support the scooter so that there is no danger of it falling over.

2. Install

- Handlebar ①
- Flange bolt ②

Align the lower handlebar holder with the upper groove of steering.

- Handle lever assembly (L)
- Handlebar grip (L)
- Handle lever comp (R)
- Left / right brake lever

TIP

Lubricate the inside of the throttle grip with a thin coat of lithium soap base grease and install it onto the handlebar.

LOWER BRACKET



LOWER BRACKET

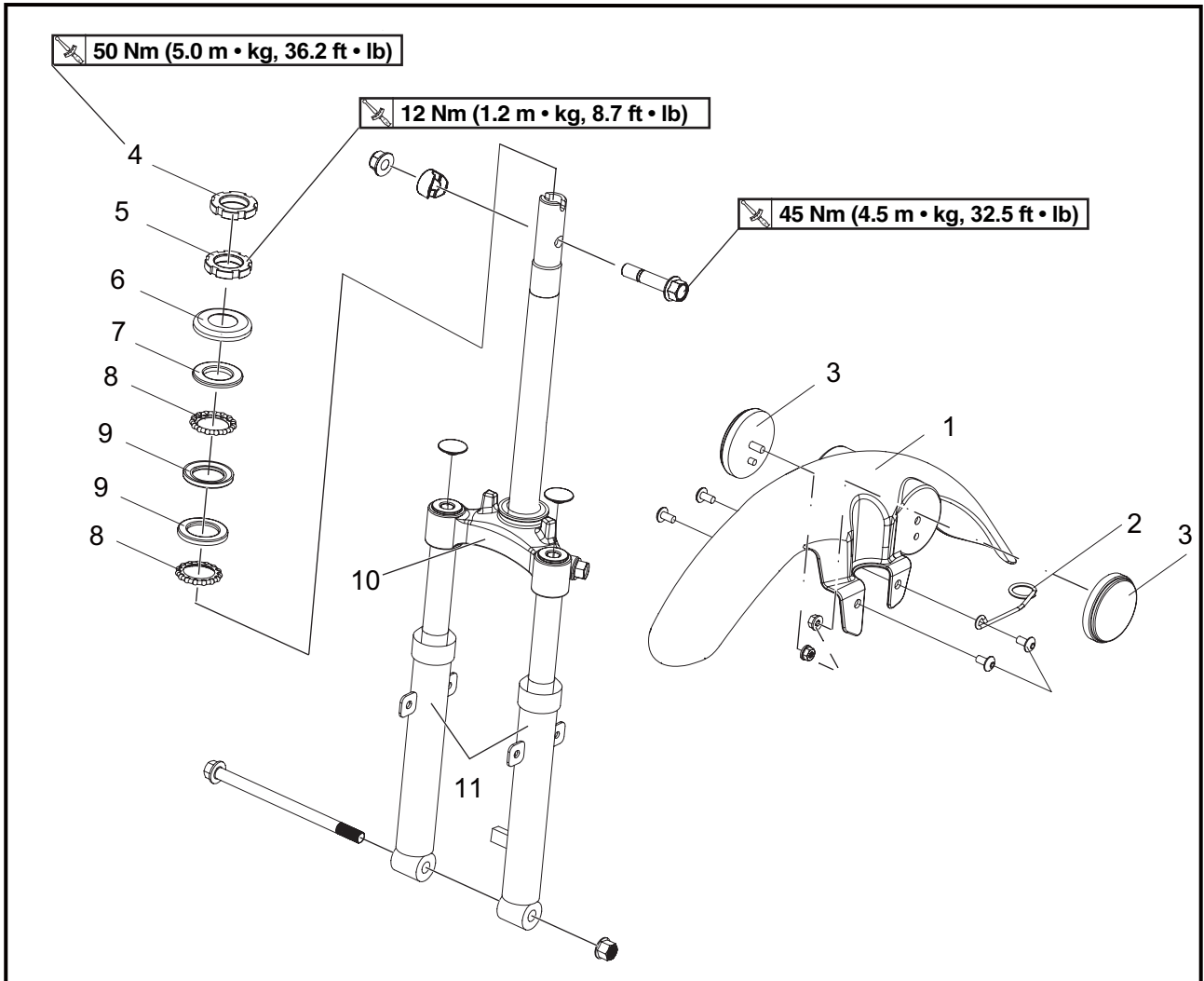

Order	Job/Part	Q'ty	Remarks
	Remove the lower bracket. Front wheel		Remove the parts in the order listed. Refer to "FRONT WHEEL/ REAR WHEEL".
1	Front fender	1	
2	Break hose holder	1	
3	Circle reflector	2	
4	Upper ring nut	1	
5	Lower ring nut	1	
6	Ball race cover	1	
7	Ball race upper	1	
8	Bearing ball	2	
9	Ball race outer	2	
10	Lower bracket	1	
11	Left/ right fork	1/1	
			For installation, reverse the removal procedure.

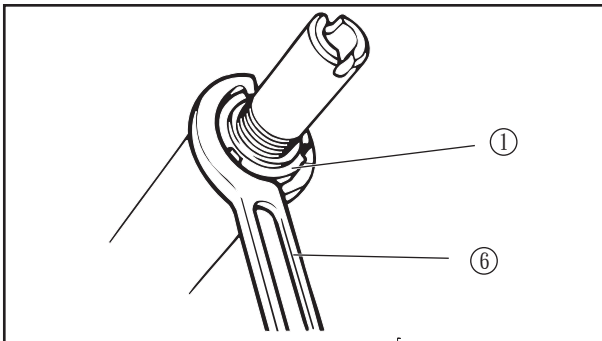

REMOVING THE LOWER BRACKET

1. Remove

- Ring nut ①
- Ball race cover ②
- Ball race upper ③
- Bearing ball ④
- Ball race outer ⑤
- Front fender assembly

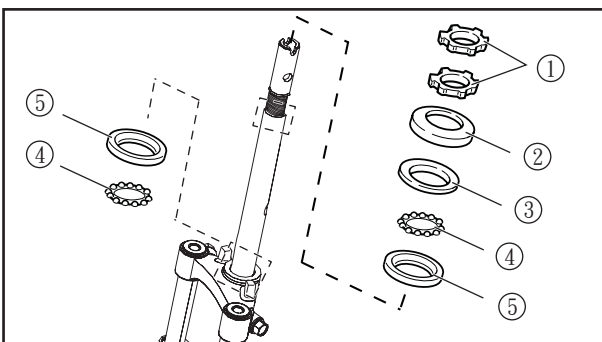

TIP

- Removing the ring nut by the steering nut wrench ⑥.
- Support the front fork safety and firmly, avoid topple and fall.
- Do not lose the bearing ball inside of the bearing.

2. Remove

- Front fender
- Please refer to "FRONT FROK" in chapter 7.

CHECKING THE LOWER BRACKET

1. Washing the bearing ball with solution.

2. Check

- Bearing ball
- Pitting/ damage → replace.

3. Check

- Lower bracket ①
- Pitting/ bends/ damage → replace.

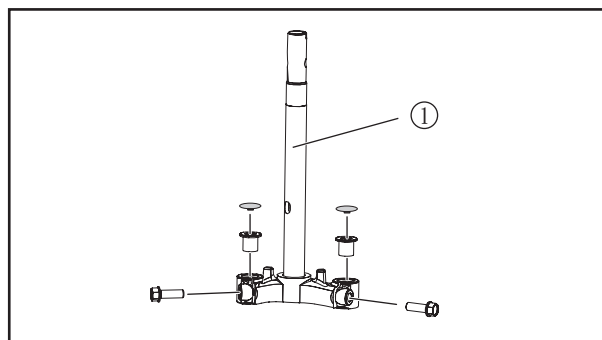

WARNING

Do not attempt to straighten a bent lower bracket as this may dangerously weaken the lower bracket.

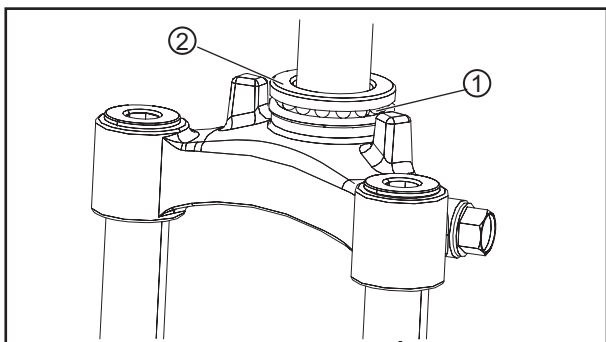

INSTALLING THE LOWER BRACKET

1. Install

- Bearing ball ①
- Outer bearing race ②

NOTICE

- Make sure the bearing ball size is correct.
- Make sure the site of up and down while installing outer bearing race and upper bearing race.

2. Lubricate

- Bearing ball ①
Please use lithium-soap-based grease to smear.

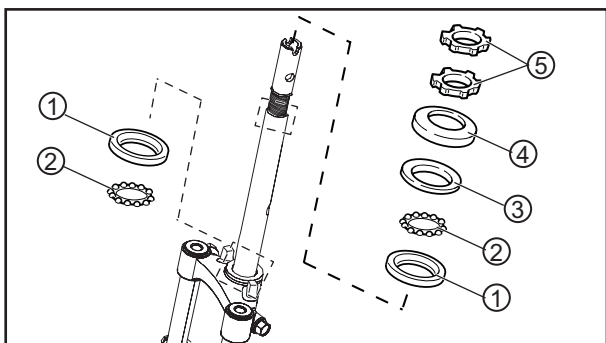
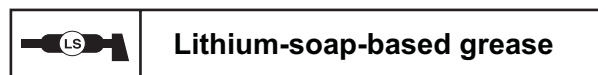

3. Install

- Front fender assembly
- Ball race outer ①
- Bearing ball ②
- Ball race upper ③
- Ball race cover ④
- Ring nut ⑤

TIP

Holding the front fender assembly until tighten.

4. Tighten

- Ring nut



Tighten steps :

- Tighten the ring nut ① with the ring nut wrench ②.

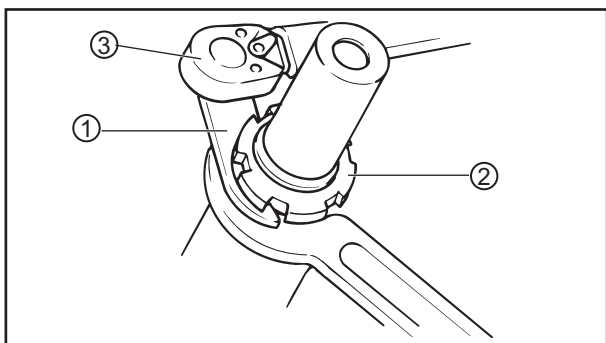

	Lower ring nut (initial tightening torque)
	35Nm (3.5m • kg, 25.3ft • lb)
	Lower ring nut (final tightening torque)
	12Nm (1.2m • kg, 8.7ft • lb)
	Upper ring nut
	50 Nm (5.0 m • kg, 36.2 ft • lb)

TIP

Install a ring nut wrench on the steering nut wrench ③ and tighten by verticality and get the tightening torque.

LOWER BRACKET

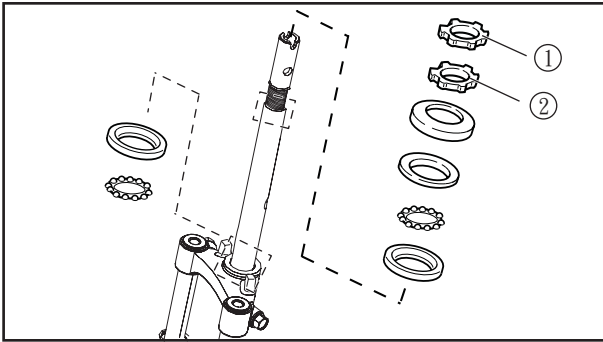

- Tighten the ring nut, please refer to "CHECKING STEERING HEAD " in chapter 3.



FRONT FORK



FRONT FORK

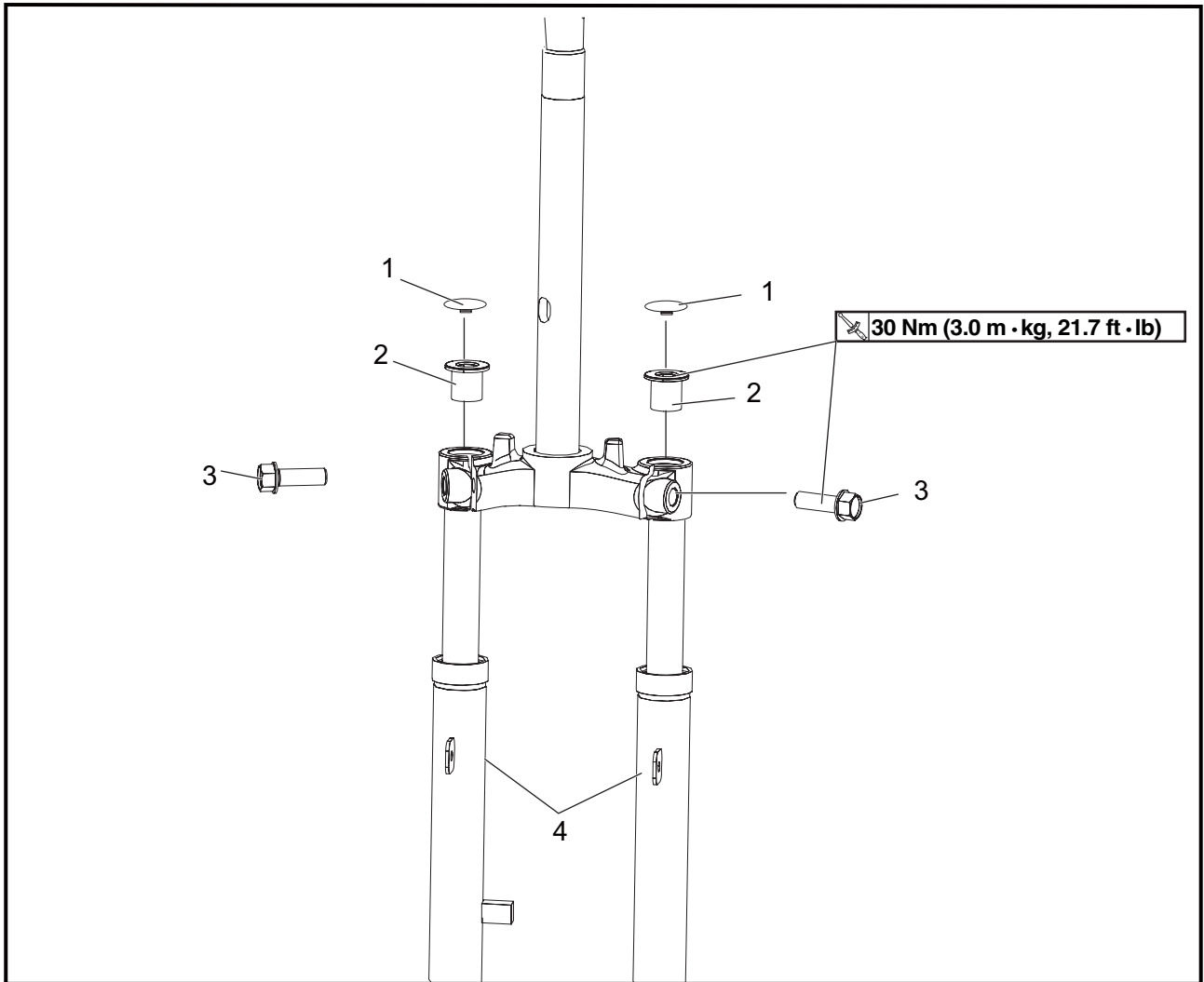

Order	Job/Part	Q'ty	Remarks
	Remove the front fork.		Remove the parts in the order listed.
1	Cap (L / R)	2	
2	Nut (L / R)	2	
3	Bolt (L / R)	2	
4	Front fork (L / R)	2	For installation, reverse the removal procedure.

REMOVING THE FRONT FORK

⚠ WARNING

- Securely support the scooter so that there is no danger of it falling over.

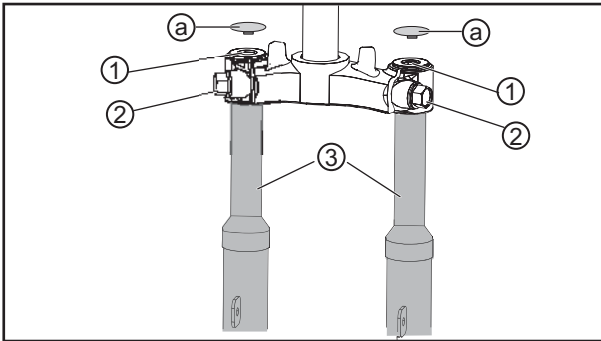

1. Remove

- Cap (a)
- Nut (fork) (1)
- Bolt (2)

⚠ WARNING

The fork spring would spring, should pay attention when remove the bolt.

- Front fork (L/ R) (3)

DISASSEMBLE THE FRONT FORK

1. Remove

- Inner tube (1)
- Dust seal (2)
- Circlip
- Oil seal (3)
- Outer tube

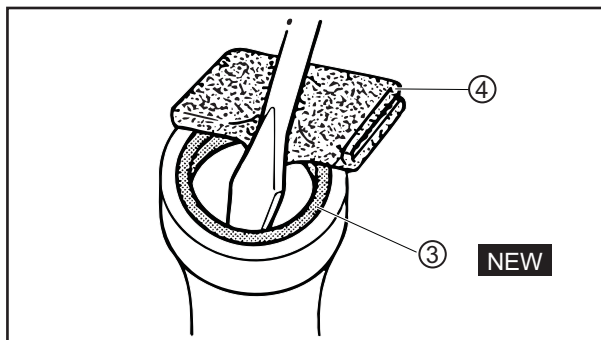
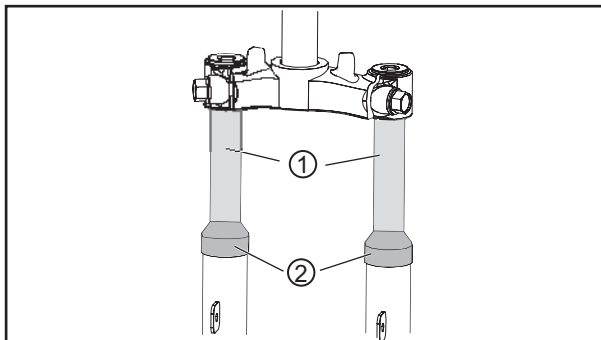

NOTICE

Do not reuse the oil seal.

- Wiper (4)

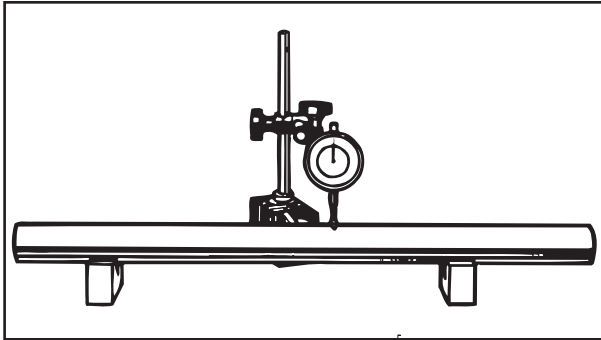

CHECKING THE FRONT FORK

1. Check
 - Inner tube
 - Wears/ bends/ damage → replace.

WARNING

Do not try to straighten an outer tube or an inner tube as this may dangerously weaken the tube.

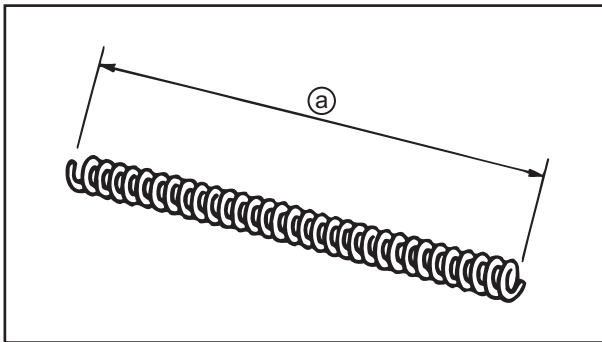

2. Measure
 - Fork spring (a)
 - Above specified limit → replace.



Fork spring free length
99.0 mm (3.90 in)
<limit> : 94.0 mm (3.70 in)

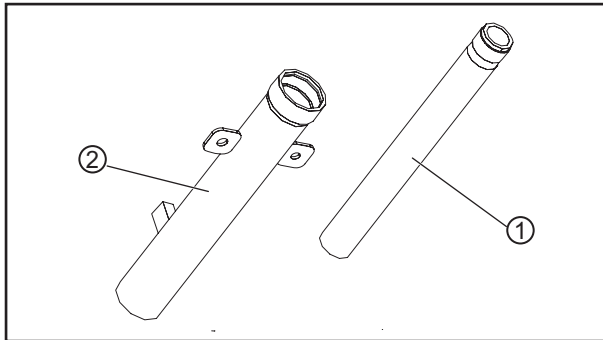

ASSEMBLING THE FRONT FORK

Reverse the disassembly procedure. Bear in mind the following points.

1. Install
 - Fork spring
 - Spring washer
 - Mini spring
 - Washer
 - Inner tube

Combine the inner tube ① with outer tube ②.

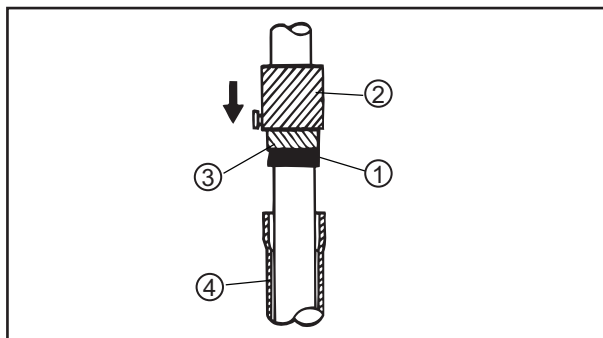

2. Install
 - Oil seal ① **NEW**
 - Use a hammer ② and conduit ③ for install the oil seal.
 - ④ Outer tube.

TIP

Before installing the oil seal, apply lithium soap base grease to the oil seal lips.

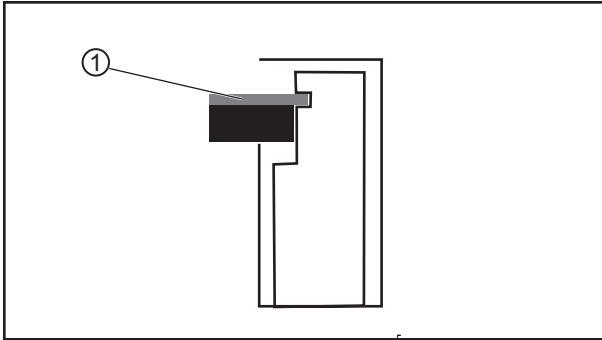

3. Install

- Circlip ①
- Dust seal

TIP

Couple the circlip correctly on the groove of the outer tube.

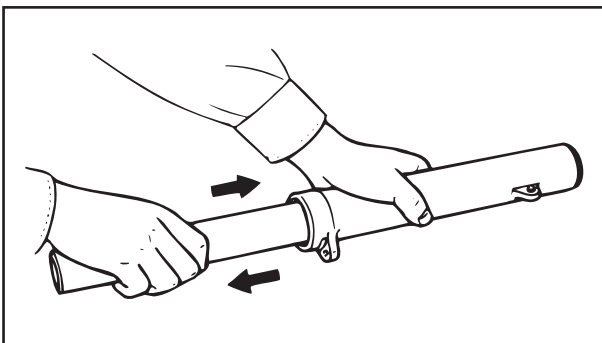

4. Check

- Operation of inner tube
- Unsmooth operation → replace.

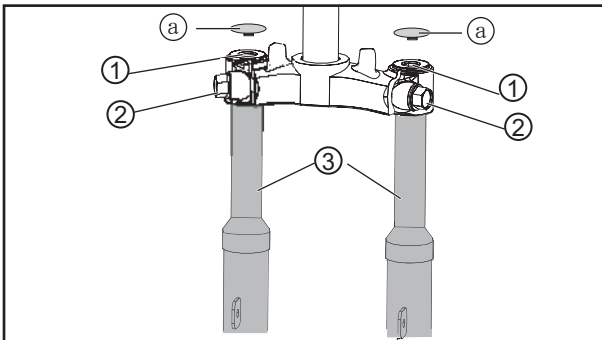

INSTALLING THE FRONT FORK

Reverse the disassembly procedure. The following points should be remembered.

1. Install

- Front fork ③

2. Tighten

- Nut (fork) ①

	30 Nm(3.0 m•kg, 21.7 ft•lb)
---	-----------------------------
- Bolt ②

	30 Nm(3.0 m•kg, 21.7 ft•lb)
---	-----------------------------
- Cap ④

CHAPTER 8

TROUBLE SHOOTING

STARTING FAILURES	8-1
Meter t has no display and no response	8-1
Lasting meter warning tone	8-1
Main switch "ON", turn handle bar the vehicle no reaction	8-1
POOR RIDING PERFORMANCE	8-1
LIGHT ODES NOT LIGHT	8-1
WHILE RIDING LOST ELECTRICITY SUDDENLY	8-1
WARNING TONE	8-1
POOR BRAKING PERFORMANCE	8-2
FAULTY FRONT FORK LEGS	8-2
HORN DOES NOT SOUND	8-2
FAULTY LIGHTING OR SIGNALING SYSTEM	8-2
Headlight does not light	8-2
Light bulb burnt out	8-2
Turn signal does not light	8-2
Turn signal remains lit	8-2
Turn signal blinks slowly	8-2
Turn signal blinks quickly	8-2
MESSAGE CODE	8-3
Meter m message code 、 warning message(warning tone) drawing	8-3
Warning and Cue signal	8-3

TROUBLESHOOTING

TIP

The following guide for troubleshooting does not cover all the possible causes of trouble. It should be helpful, however, as a guide to basic troubleshooting.

Refer to the relative procedure in this manual for checks, adjustments, and replacement of parts.

STARTING FAILURES

Meter t has no display and no response

- Have not put the battery.
- Faulty battery.
- Battery protecting (turn off the main switch and wait about 15 seconds, turn on the main switch again).
- Battery contact bad connection.
- Blown, damaged or incorrect fuse.
- Wiring contact bad connection or damage.
- Faulty main switch.
- Faulty meter.
- Faulty driver.

Lasting meter warning tone

- Wiring contact bad connection or damage.
- Faulty driver.
- Faulty meter.

Main switch "ON", turn handle bar the vehicle no reaction

- Wiring contact bad connection or damage.
- Faulty handle bar switch.
- Faulty motor.
- Faulty driver.

POOR RIDING PERFORMANCE

- Wiring contact bad connection or damage.
- Faulty motor.
- Faulty driver.
- Brake drag.

LIGHT ODES NOT LIGHT

- Driving modes is set standard mode.
- Wiring contact bad connection or damage.
- Burnt-out light bulb.

WHILE RIDING LOST ELECTRICITY SUDDENLY

- Driving modes is set standard mode.
- Faulty main fuse.
- Faulty battery.
- Faulty driver.

WARNING TONE

E-MO will notify vehicle operation and movement starts by sending out warning tone.

◆ Warning tone list

O: Tone X: No tone

Vehicle operation	Warning tone
Main switch ON	O
Press an operation button	O
Password decode	O
Wrong password	O
No operation for 30 seconds	O
10% battery residual volume	O
Warning and warning message	O
Main switch OFF	X

POOR BRAKING PERFORMANCE

- Worn brake shoe lining.
- Incorrect brake lever free play.
- Incorrect brake shoe position.
- Wearing brake camshaft.
- Worn or rusty brake drum.
- Dust or water on the brake drum.
- Oil or grease on the brake drum.
- Worn brake cable wire.
- Worn brake spring.
- Worn brake camshaft and brake lever.

FAULTY FRONT FORK LEGS

- Bent or damaged inner tube.
- Bent or damaged outer tube.
- Damaged fork spring.
- Bent or damaged damper rod.
- Incorrect oil viscosity.
- Incorrect oil level.

HORN DOES NOT SOUND

- Faulty battery.
- Blown, damaged or incorrect fuse.
- Faulty main switch / horn switch.
- Improperly adjusted horn.
- Damaged or faulty horn.
- Faulty wire harness.

FAULTY LIGHTING OR SIGNALING SYSTEM**Headlight does not light**

- Wrong headlight bulb.
- Too many electrical accessories.
- Hard charging.
- Faulty battery.
- Incorrect connection.
- Improperly grounded circuit.
- Poor contacts (main or light switch).
- Headlight bulb life expired.

Light bulb burnt out

- Wrong light bulb.
- Faulty battery.
- Improperly grounded circuit.
- Poor contacts (main or light switch).
- Light bulb life expired.

Turn signal does not light

- Improperly grounded circuit.
- Faulty battery.
- Blown, damaged or incorrect fuse.
- Faulty turn signal switch.
- Faulty turn signal relay.
- Damaged or faulty wire harness.
- Burnt-out turn signal bulb.

Turn signal remains lit

- Faulty turn signal relay.
- Faulty battery.
- Burnt-out turn signal bulb.

Turn signal blinks slowly

- Faulty turn signal relay.
- Faulty battery.
- Incorrect turn signal bulb.
- Poor contacts (main or light switch).

Turn signal blinks quickly

- Faulty turn signal relay.
- Incorrect turn signal bulb.

MESSAGE CODE

Meter message code · warning message(warning tone) drawing

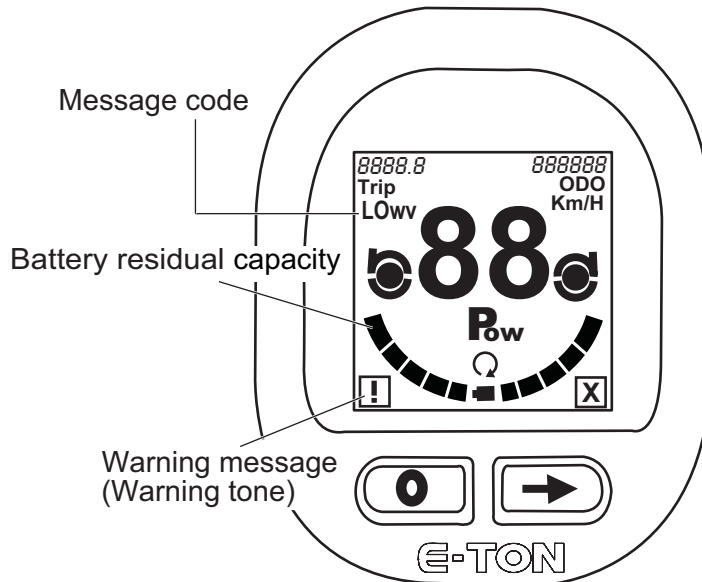

The following warning messages might display with a warning tone during riding status.

◆ Warning and Cue signal

	Code	Cause	Action
Warning 	OVC2 OVC1	The controller detects increasingly high electric current. The power of the motor disappears while the warning message and warning sound are given out.	1. Release the accelerator and let go of hands. Wait until the message disappears then continue on driving. 2. If the warning message does not disappear, or if this warning message appears a lot, take the motor to the service station for check up.
	OV T	The controller detects increasingly high temperature. The power of the motor disappears while the warning message and warning sound are given out.	1. Wait for the controller to cool down before driving continues. 2. If the warning message does not disappear, or if this warning message appears a lot, take the motor to the service station for check up.
	OV V	The controller detects increasingly high voltage. The power of the motor disappears while the warning message and warning sound are given out.	1. Restart. 2. If the warning message does not disappear, or if this warning message appears a lot, take the motor to the service station for check up.
	LOWV	The controller detects decreasingly low voltage. The power of the motor disappears while the warning message and warning sound are given out.	1. Restart. 2. If the warning message does not disappear, or if this warning message appears a lot, take the motor to the service station for check up.
	STL1	Strong resistance (stalling) at startup or during moving. The power of the motor disappears while the warning message and warning sound are given out.	1. Release the accelerator and let go of hands. Wait until the message disappears then continue on driving. 2. If the warning message does not disappear, or if this warning message appears a lot, take the motor to the service station for check up.
	NO B	This message appears when the battery is completely exhausted to remind the user to recharge the battery.	Residual capacity of battery is around 10%. Recharge the battery as soon as possible.
Indication	CHAR	Remind that the battery is charging.	Wait for the battery to be fully charged.
	FULL	Remind that the battery charging has already completed.	Remove the battery charger.

	Code	Cause	Action
Indication	SPD0	Operate code lock during riding.	No operating code lock during riding can terminate this message.
	FAST	Over speed warning. (over 52KM/HR)	Reducing driving speed as soon as possible.
	LOWB	Low battery.	Recharge battery as soon as possible.
	LOWP	Using Power mode during low battery residual charge.	The system will shift back to standard mode automatically and LOWP will disappear.
	LOCK	1. This message will display to remind the rider that vehicle locking has already been set success fully. 2.This message will display on restarting to remind that the vehicle locking has already been set success fully.	1. Rider can switch off safely.
			2. Press confirmation button and input password to unlock the vehicle.
	FAIL	Wrong password.	Re-enter the password.
	OLD	On setting vehicle locking password, this message will display to remind the rider to input old password if an old password has already existed.	Enter the old password.
	NEW	ON setting vehicle locking password, this message will display to remind the rider to input a new password if there are no password was set up in system or already enter the correct password.	Enter the new password.
	PUSH	During standby mode, this message will display to remind the user to press confirmation button to enter into riding page.	Press confirmation button A.
PRES	After starting. This message will display to remind the rider if the vehicle still stays in standby page but the rider intends to turn around handlebars.	Release throttle handle and press confirmation button to enter into riding page.	
TPS0	After PRESS is conducted, this message will display to remind the rider if the confirmation button is pressed before handle bar is not yet released.	Release throttle handle and press confirmation button to enter into riding page.	