

**JW 50/90/100**  
**CPI**  
**SERVICE MANUAL**

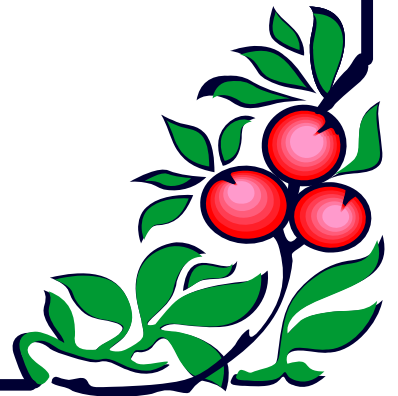

## §CONTENTS §

一、 TECHNICAL INFORMATION.....	1~4
二、 TROUBLE SHOOTING.....	5~9
三、 MAINTENANCE.....	10~15
3-1 MAINTENANCE SCHEDULE.....	10
3-2 MAINTENANCE DATA.....	10
3-3 FUEL TUBE.....	11
3-4 THROTTLE OPERATION.....	11
3-5 THROTTLE CABLE ADJUSTMENT.....	11
3-6 AIR CLEANER.....	11
3-7 SPARKK PLUG.....	12
3-8 IDLE SPEED.....	12
3-9 DRIVE CHAIN.....	12~13
3-10 BRAKE SYSTEM.....	13~14
3-11 WHEELS AND TIRES.....	14
3-12 STEERING SYSTEM.....	14
3-13 TOE-IN.....	15
3-14 GEAR OIL.....	15
四、 ENGINE SYSTEM.....	16~36
4-1 ENGINE REMOVAL AND INSTALLATION.....	16
4-2 ENGINE FUEL SYSTEM.....	17~18
4-3 ENGINE LUBRICATION AND COOLING SYSTEM.....	18~20
4-4 ENGINE COMBUSTION SYSTEM.....	20~25
4-5 TANSMISSION SYSTEM.....	25~31
4-6 CRANKSHAFT / CRANKCASE.....	31~35
4-7 A.C.G ENERATOR.....	35~36
五、 CARBURETOR SYSTEM.....	37~40
5-1 CARBURETOR REMOVAL.....	37
5-2 STARTER PLUNGER INSPECTION.....	38
5-3 FLOAT CHAMBER DISASSEMBLY.....	38~39
5-4 FUEL HEIGHT INSPECTION.....	39
5-5 CARBURETOR INSTALLATION.....	39~40
5-6 REED VALVE.....	40
六、 FRAME SYSTEM.....	41~57
6-1 FRONT WHEEL AND STEERING SYSTEM.....	41~50
6-2 REAR WHEELS.....	50~54
6-3 FENDERS AND EXHAUST PIPE.....	55~57
七、 ELECTRICAL SYSTEM.....	58~62
7-1 TROUBLESHOOTING.....	58
7-2 BATTERY REMOVAL / INSTALLATION .....	59
7-3 A.C.G. INSPECTION.....	59~60
7-4 RESISTER INSPECTION.....	60
7-5 C.D.I. INSPECTION.....	60
7-6 IGNITION COIL INSPECTION.....	60~61
7-7 START MOROTR.....	61
7-8 START RELLEY INSPECTION.....	61



**SAFETY**

- GASOLINE IS EXTREMELY FLAMMABLE AND IS EXPLOSIVE UNDER CERTAIN CONDITION.  
DO NOT SMOKE OR ALLOW SPARKS OR FLAMES IN YOUR WORK AREA.
- NEVER RUN THE ENGINE IN A CLOSED AREA. THE EXHAUST GAS CONTAINS POISONOUS CARBON MONOXIDE THAT MAY CAUSE LOSS OF CONSCIOUSNESS AND LEAD TO DEATH.
- THE BATTERY ELECTROLYTE CONTAINS SULFURIC ACID. PROTECT YOUR EYES, SKIN AND CLOTHING. IF YOU CONTACT IT, RINSE THOROUGHLY WITH WATER AND CALL A DOCTOR IF ELECTROLYTE GETS IN YOUR EYES.

**PREFACE**

THE CONTENTS OF THIS MANUAL PROVIDE THE SERVICE INFORMATION FOR C.P.I **JW50/90/100**

MOST CHAPTERS START WITH A SYSTEM OR ASSEMBLY ILLUSTRATION AND SPECIFICATIONS THE FOLLOWED PAGES GIVE DETAIL PROCEDURES.

IF YOU DO NOT KNOW WHAT THE SOURCE OF THE TROUBLE IS, PLEASE GO TO THE TROUBLESHOOTING FOR ADDITIONAL HELP.

ALL THE CONTENTS OF THIS MANUAL ARE BASED ON THE LATEST MODEL INFORMATION C.P.I RESERVE THE RIGHT TO MAKE CHANGE AT ANY TIME WITHOUT NOTICE AND WITHOUT ANY RESPONSIBILITY OR ENGAGEMENT ON OUR PART.

## SPECIFICATION

ATV TYPE	JW50	JW90	JW100
<b>ENGINE</b>			
Type	CPI50S	CPI90S	CPIOAS
Displacement	49.8c.c	82c.c	91.3c.c
Bore and stroke	$\varphi$ 40.0x39.6 mm	$\varphi$ 50.0x42 mm	$\varphi$ 52.0x43.0 mm
Compression	6.9:1	6:1	6.6:1
Carburetion	Mikuni	Mikuni	Mikuni
Ignition	Capacitor Discharge	Capacitor Discharge	Capacitor Discharge
Starting	Electric	Electric	Electric
Lubrication	Oil Pump Separate Supply	Oil Pump Separate Supply	Oil Pump Separate Supply
Oil tank capacity	1 liter	1 liter	1 liter
Transmission	Automatic	Automatic	Automatic
<b>CHASSIS</b>			
Overall Length	1370 mm	1395 mm	1395 mm
Overall Width	865 mm	890 mm	890 mm
Overall High	875 mm	950 mm	950 mm
Wheelbase	865 mm	900 mm	900 mm
Dry weight	103 kg	110.5 kg	110.5 kg
Fuel Tank Capacity	5 liter	5 liter	5 liter
<b>SUSPENSION</b>			
Front	Dual Arm	Dual Arm	Dual Arm
Rear	Swung Ann	Swung Ann	Swung Ann
<b>BRAKES</b>			
Front	Drum	Drum	Drum
Rear	Drum	Drum	Drum
<b>TIRE</b>			
Front	16x8-7	19x7-8	19x7-8
Rear	16x8-7	19x8-8	19x8-8
<b>COLORING</b>			
	Red/Yellow/Blue/Silver/Brack	Red/Yellow/Blue/Silver/Brack	Red/Yellow/Blue/Silver/Brack

**一、 TECHNICAL INFORMATION**

**SERIAL NUMBER**

Please record the frame and engine serial numbers for future reference. The frame serial number (1) is stamped on the front of the frame.

FRAME NO. \_\_\_\_\_

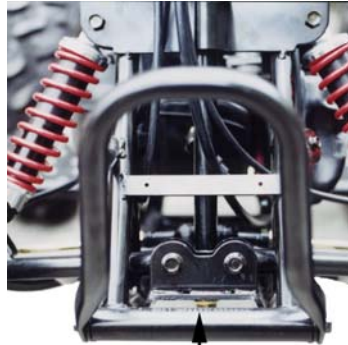

**(1) Frame serial number**

The engine serial number (2) is stamped on the left side of the engine crankcase.

ENGINE NO. \_\_\_\_\_



**(2) Engine serial number**

**一、 TECHNICAL INFORMATION****TORQUE VALUES****ENGINE**

	<b>JW50/JW90/JW100</b>
Cylinder head nut	1.3~1.5kg-m
Spark plug	1.5~2.0kg-m
Cylinder head bolt	1.4~2.0kg-m
Alternator bolt	3.5~4.0kg-m

**FRAME**

	<b>JW50/JW90/JW100</b>
Handlebar upper holder bolt	2.0~2.2kgf-m
Steering shaft nut	4.5~5.0kgf-m
Steering shaft bushing holder nut	2.0~2.2kgf-m
Wheel rim bolt	3.5~4.0kgf-m
Tie rod lock nut	3.0~3.5kgf-m
Knuckle nut	3.5~4.0kgf-m
Handlebar lower holder nut	4.5~5.0kgf-m
Front wheel bolt	3.5~4.0kgf-m
Front axle nut	4.0~4.5kgf-m
Rear axle nut	4.5~5.0kgf-m
Rear wheel bolt	3.5~4.0kgf-m
Exhaust muffler mounting bolt	0.7~1.0kgf-m
Engine hanger bolt	2.0~2.3kgf-m
Drive sprocket 19T	4.5~5.0kgf-m

**二、TROUBLESHOOTING**

JW50/90/100

**ENGINE DOES NOT START**

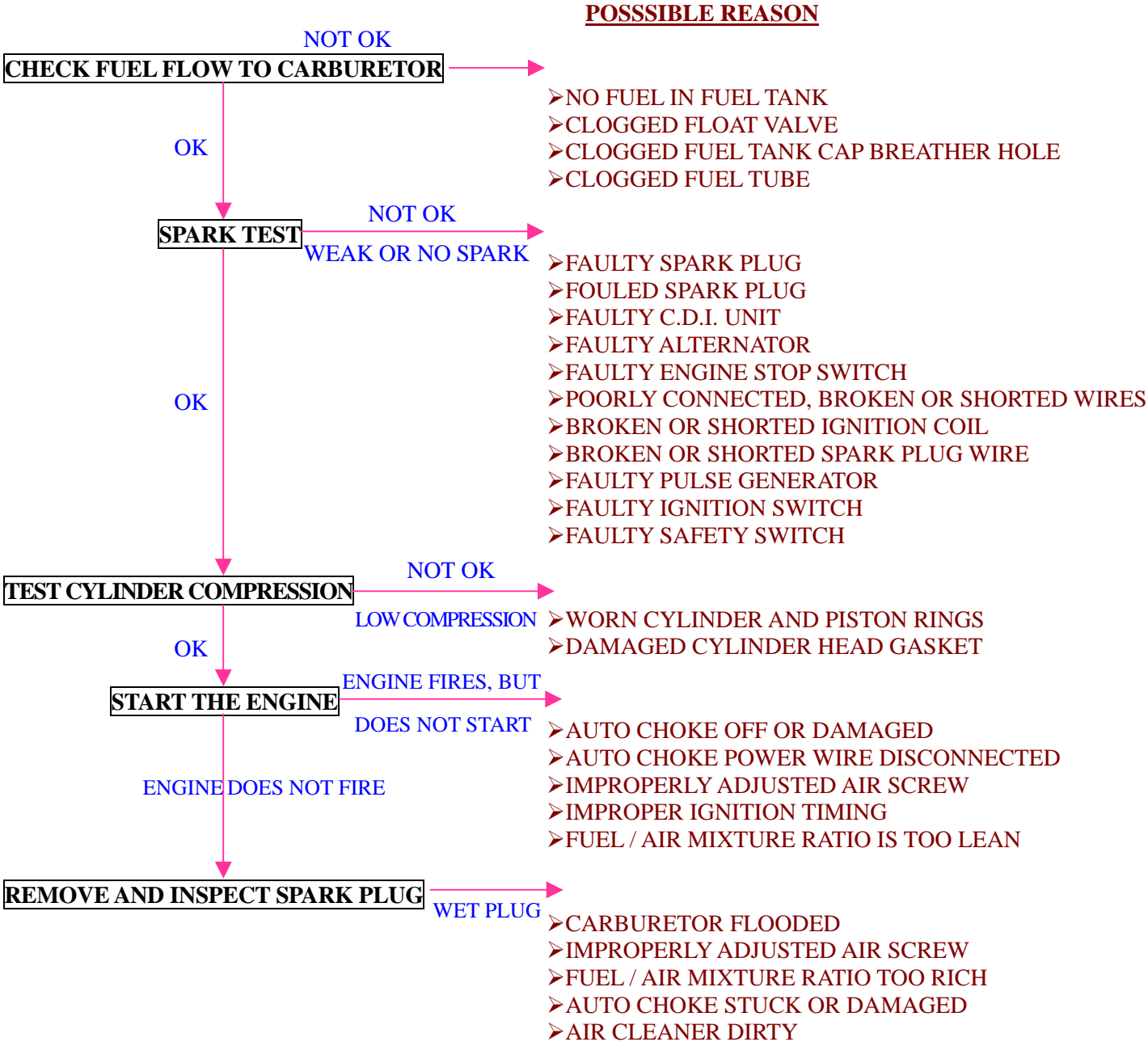



**二、TROUBLESHOOTING**

JW50/90/100

**POOR PERFORMANCE AT LOW AND IDLE SPEEDS**

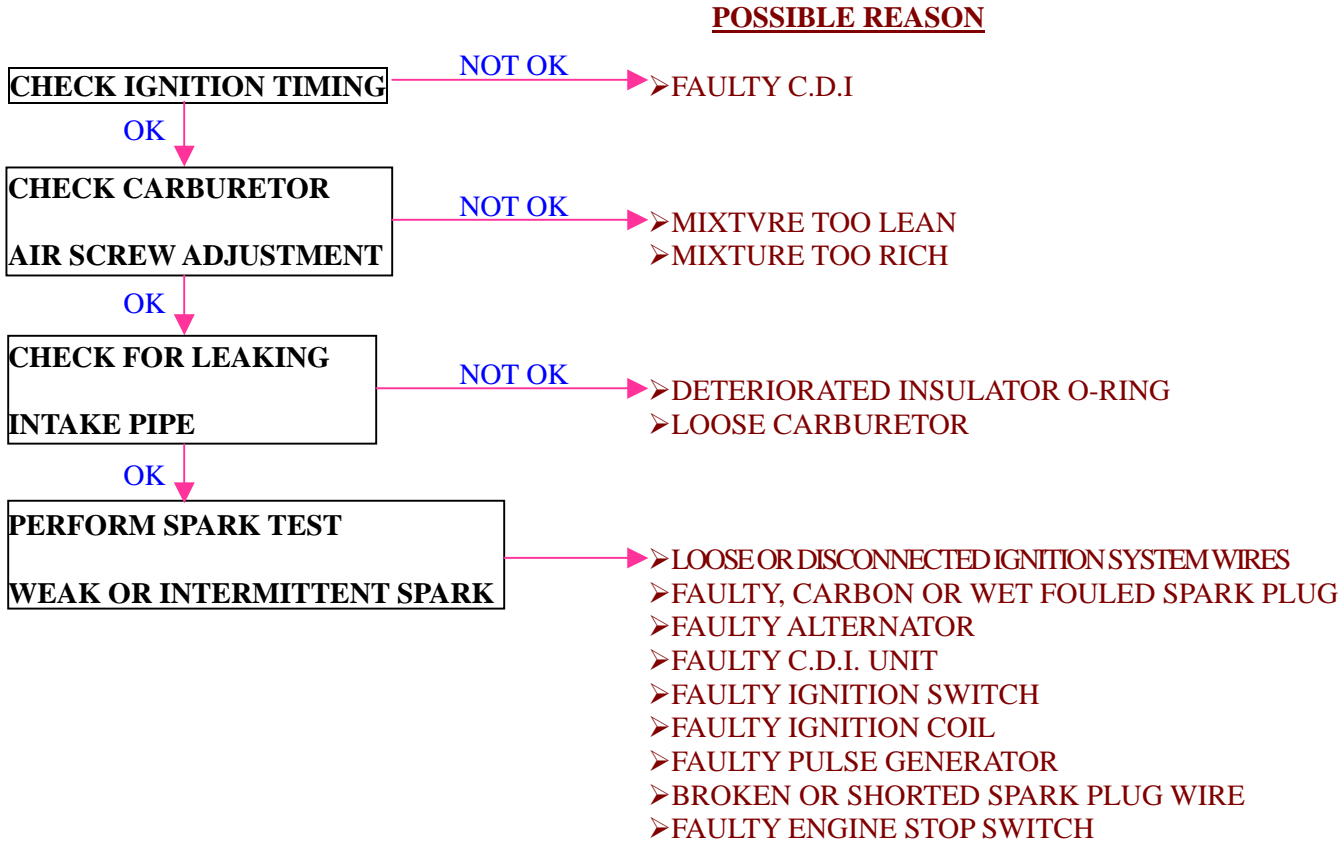

**二、TROUBLESHOOTING**

JW50/90/100

**POOR PERFORMANCE AT HIGH SPEED**

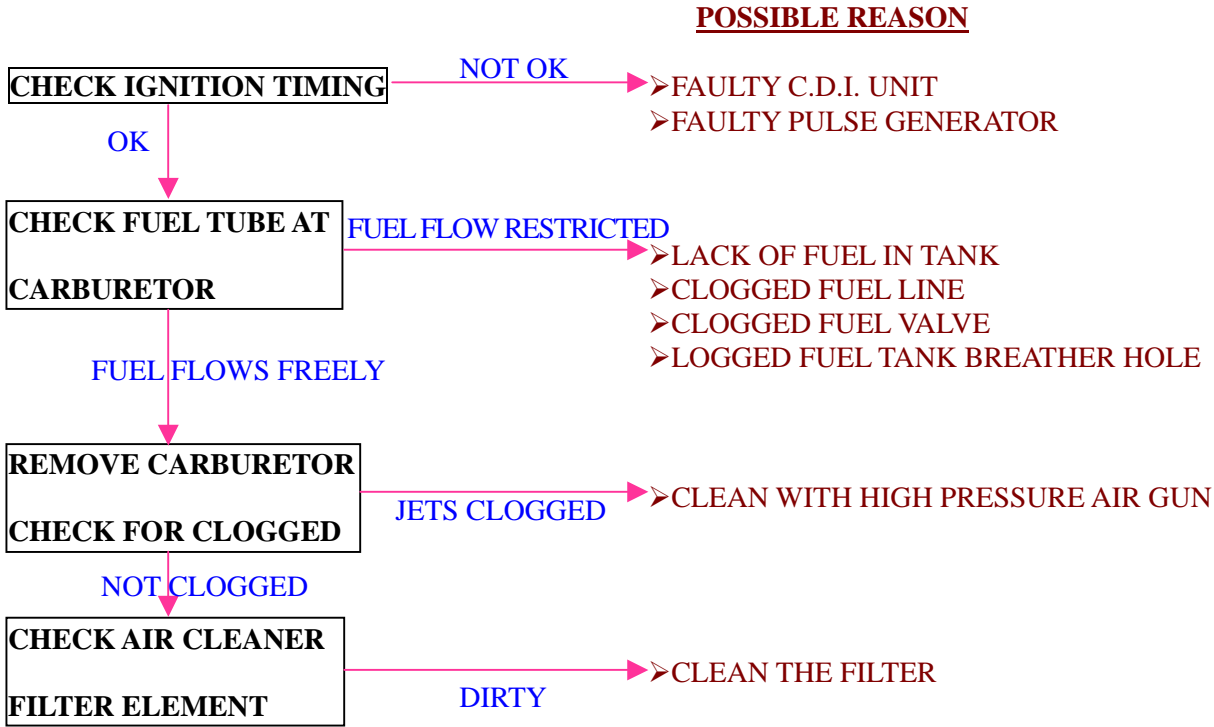

二、TROUBLESHOOTING

JW50/90/100

LOSS POWER

POSSIBLE REASON

RAISE WHEELS OFF GROUND AND SPIN BY HEND

DOES NOT SPIN FREELY

- BRAKE DRAGGING
- DRIVE CHAIN TOO TIGHT
- DAMAGED WHEEL BEARING
- WHEEL BEARING NEEDS LUBRICATION

SPIN FREELY

CHECK TIRE PRESSURE

PRESSURE LOW

- PUNCTURED TIRE
- FAULTY TIRE VALVE

PRESSURE NORMAL

ACCELERATE SLOWLY

ENGINE SPEED DOES NOT INCREASE

- FUEL/AIR MIXTURE RATIO TOO RICH OR LEAN
- CLOGGED IN AIR CLEANER
- CLOGGED IN MUFFLER
- RESTRICTED FUEL FLOW
- CLOGGED FUEL TANK CAP BREATHER HOLE

ENGINE SPEED INCREASES

CHECK IGNITION TIMING

NOT OK

- FAULTY PULSE GENERATOR
- FAULTY C.D.I. UNIT

OK

TEST CYLINDER COMPRESSION

TOO LOW

- LEAKING HEAD GASKET
- WORN CYLINDER AND PISTON RINGS

OK

CHECK CARBURETOR

CLOGGED

- CLEAN

OK

CHECK SPARK PLUG

FOULED OR DISCOLORED

- CLEAN THE SPARK PLUG
- SPARK PLUG IS INCORRECT HEAT RANGE

OK

CHECK FOR ENGINE OVERHEATING

OVERHEATING

- EXCESSIVE CARBON DEPOSITED IN COMBUSTION CHAMBER
- WRONG TYPE OF FUEL
- FUEL/AIR MISTURE RATIO IS LEAN
- USE OF POOR QUALITY FUEL

OK

ACCELERATE OR RUN AT HIGH SPEED

KNOCKS

- WORN PISTON AND CYLINDER
- FUEL/AIR MIXTURE RATIO IS LEAN
- WRONG TYPE OF FUEL
- IGNITION TIMING TOO ADVANCED
- EXCESSIVE CARBON DEPOSITED IN

**二、TROUBLESHOOTING**

JW50/90/100

COMBUSTION CHAMBER

**POOR HANDLING**

**POSSIBLE REASON**

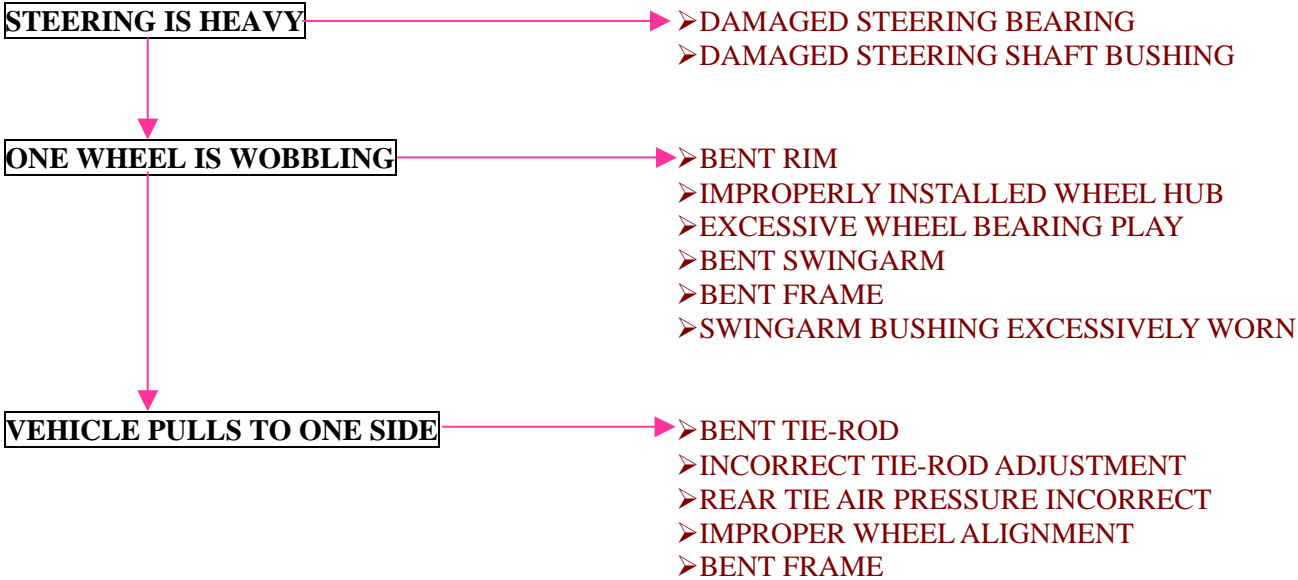

## ☰ MAINTENANCE

### 3.1 MAINTENANCE SCHEDULE

The maintenance intervals in the table below is based upon average riding and conditions. Riding in unusually dusty areas, require more frequent servicing

C: Clean      L: Lubricate      R: Replace      I: Inspect and Clean, Adjust, Lubricate or Replace, if necessary

	INITIAL SERVICE (First week)	REGULAR SERVICE (Every 30 operating days)	EVERY YEAR
FUEL LINE			I
THUOTTLE OPERATION	I	I	
AIR CLEANER		C	
SPARK PLUG		I	
CARBURETOR IDLE SPEED	I	I	
DRIVE CHAIN	L,I	L,I	
BRAKE SHOE WEAR			I
BRAKE SYSTEM	I	I	
NUT, BOLT, FASTENER	I	I	
WHEEL	I	I	
STEERING SYSTEM			I
SUSPENSION SYSTEM			I
C.V.T. AIR FILTER		C	
GEAR OIL			R

### 3.2 MAINTENANCE DATA SPECIFICATION

	JW50/JW90/JW100
SPARK PLUG GAP	0.7-0.8 mm
RECOMMENDED SPARK PLUGS	NGK BPR7HS
THROTTLE LEVER FREE PLAY	5-10 mm
IDLE SPEED	1800±100rpm
BRAKE LEVER FREE PLAY	15-20 mm
DRIVE CHAIN SLACK	10-20 mm
FRONT/REAR TIRE PRESSURE	2-10psi (0.15-0.7bar)
TOE-IN	6~10 mm
ENGINE OIL	SAE10W-40
GEAR LUBRICATION OIL	SEA 90
BATTERY	12V-5AM

## ☰ MAINTENANCE

### 3.3 FUEL TUBE

Inspect the fuel lines for deterioration, damage or leakage and replace if necessary.

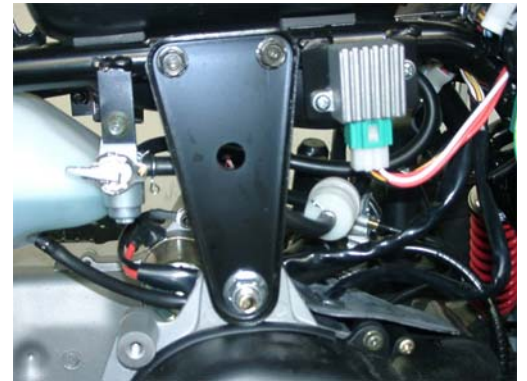

### 3.4 THROTTLE OPERATION

Inspect for smooth throttle lever full opening and automatic full closing in all steering positions. Inspect if there is no deterioration, damage or kicking in the throttle cable, replace it if necessary.

Check the throttle lever, free play is 5-10 mm at the tip of the throttle lever.

Disconnect the throttle cable at the upper end.

Lubricate the cable to prevent premature wear.



### 3.5 THROTTLE CABLE ADJUSTMENT

Slide the rubber cap of the adjuster off the throttle

Housing, loosen the lock nut and adjust the free play of the throttle lever by turning the adjuster on the throttle housing. Inspect the free play of the throttle lever.



### 3.6 AIR CLEANER

Unscrew the air cleaner cover screws.

Pull out the air filter element from the air cleaner case.

Wash the element in non-flammable solvent, squeeze out the solvent thoroughly. Let it dry. Soak the filter element in air filter oil and then squeeze out the excess oil.

Install the element into air cleaner carefully.



## ☰ MAINTENANCE

### 3.7 SPARK PLUG

The spark plug located at the front of the engine. Disconnect the spark plug cap and unscrew the spark plug.

Check the spark plug electrodes for wear out.

Install a new spark plug if the electrodes and insulator tip appear unusually fouled or burned.

The spark plug gap must be 0.7-0.8 mm.

With the sealing washer attached, apply copper grease, and thread the spark plug in by hand to prevent cross threading.

Tighten the spark plug with 1.5-2kg-m

### 3.8 IDLE SPEED

Connect a engine speed meter.

Warm up the engine, 10 minutes are enough.

Turn the idle-speed adjust screw on the carburetor to obtain the idle speed. "Turn in" (clockwise) will get higher speed. "Turn out" (counter clockwise) will result in lower speed.

IDLE SPEED: 1800±100rpm



### 3.9 DRIVE CHAIN

Inspect the chain slack. The standard is 10-25 mm.

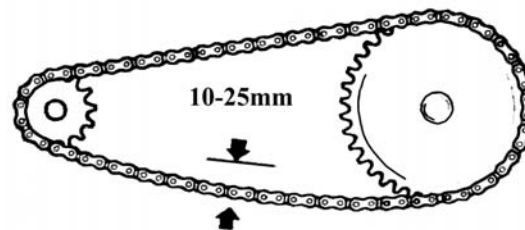

## ≡ MAINTENANCE

Adjust the chain slack.(in the rear fork)  
 Loose the lock bolts (4 PCs) then adjust the drive chain slack by turning the adjustment nut.  
 Tighten the our lock bolts.  
 Apply chain lubricant to lubricate the drive chain.

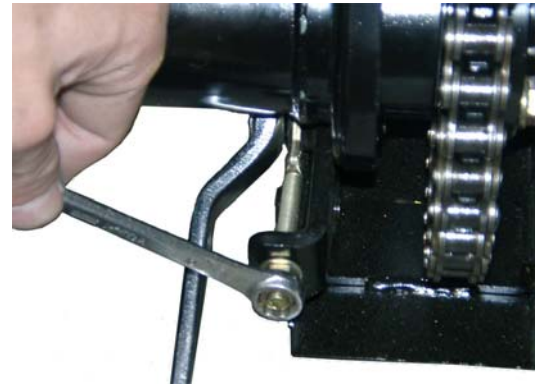

When the drive chain is very dirty, it should be removed, cleaned and lubricated with chain specific grease.  
 Clean the drive chain with kerosene and wipe it dry, and apply the lubricant.  
 Inspect the drive chain for possible wear or damage.  
 Replace the chain, if it is worn excessively or damaged.

Inspect the drive sprocket(19T), if the teeth are worn or damaged, replace it.



Inspect the rubber sleeve.  
 If the rubber sleeve are worn or damaged, replace it.





**☰ MAINTENANCE****3.10 BRAKE SYSTEM**

Inspect the front brake lever and cable for excessive free play or damage.

Replace or repair if necessary.

Measure the free play of the brake cable at the end of the brake lever. The standard free play is 15-25 mm



Inspect the rear brake lever and cable for excessive free play or damage.

Replace or repair if necessary.

Measure the free play of the rear brake cable at the end of the lever, The standard free play is 15-25 mm



Adjust the free play of the rear brake lever by turning the adjuster on the rear axle.

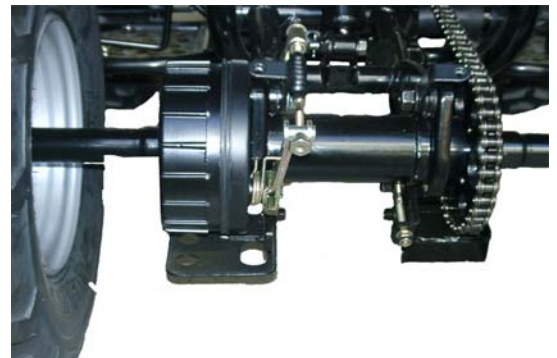

## ☰ MAINTENANCE

### 3.11 WHEELS AND TIRES

Inspect the tire surfaces for cuts, nails or other sharp objects.

Check the pressure at cold tire condition..

The standard of tire pressure is

JW50 : 3~6Psi

JW90 : 3~6Psi

JW100: 3~6Psi



### 3.12 STEERING SYSTEM

Check the free play of the steering shaft with the front wheels, steering straight ahead.

When there is excessive play, inspect the tie-rod, knuckle bushing and ball joint.



### 3.13 TOE-IN

Park the vehicle on level ground and the front wheels facing straight ahead.

Mark the centers of the tires to indicate the axle center height.

Measure the distance between the marks.

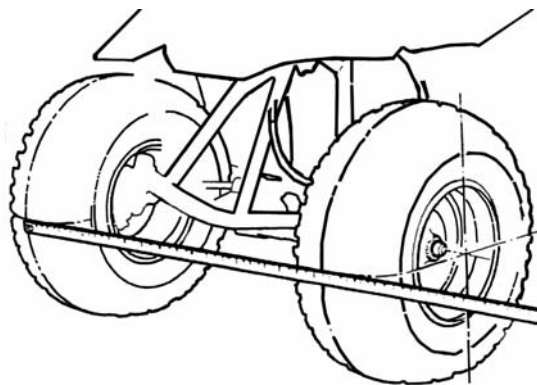

## ≡ MAINTENANCE

Carefully move the vehicle back, let the wheels have turned 180°, so the marks on the tires are aligned with the axle center height.

Measure the distance between the marks.

Calculate the difference in the front and rear measurements.

Toe-in: 0~10 mm

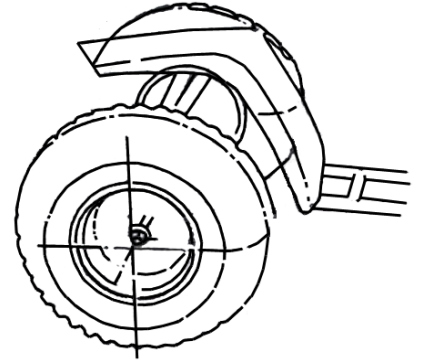

If the toe-in is out of standard, adjust it by changing the length of the tie-rods equally by turning the tie-rod while holding the ball joint.

Tighten the lock nuts.

(A) Touque: 3.0~3.5kgf-m

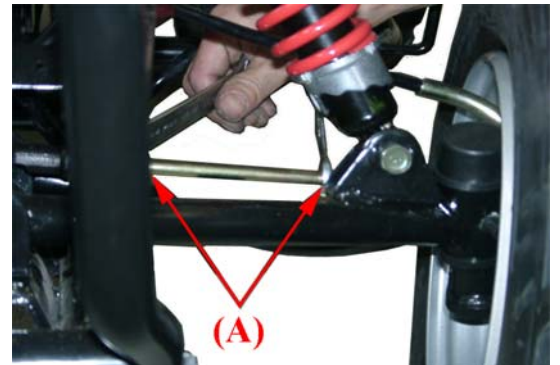

### 3.14 GEAR OIL

Gear oil needs to be changed every year.

There is gear oil release bolt at the rear of engine.

Unscrew this release bolt and can let the dirty oil flow out.

The re-add oil hole is on the engine case besides the gear box.

## 四、ENGINE SYSTEM

JW50/90/100

### 4-1 ENGINE REMOVAL AND INSTALLATION

**4-1-1 ENGINE SHALL BE REMOVED IN THE CONDITIONS OF NECESSARY REPAIRMENT OR ADJUSTMENT TO THE TRANSMISSION AND COMBUSTION SYSTEM ONLY**

#### 4-1-2 ENGINE REMOVAL

Remove the seat and rear side cover fender.

Remove the spark plug cap from the spark plug.

Remove the exhaust pipe.

Disconnect the carburetor.

Take off the oil pump cable from the oil pump control plate.

The oil pump is on the right side of the engine.



Discontent the wire connectors.

There are three connectors.:

carburetor auto-choke

starter motor

generator

Remove the drive chain cover.

Remove the drive chain retaining clip and master link, and remove the drive chain.



Remove the three engine mounting nuts and bolts.

Remove the engine from the right side of frame.



**四、ENGINE SYSTEM**

**JW50/90/100**

**4-1-3 ENIGNE INSTALLATION**

Engine installation is essentially the reverse order of removal.  
The torque of the engine mounting bolts is 4.5~5.0kg-m  
Route the wires and cable in reverse order properly.

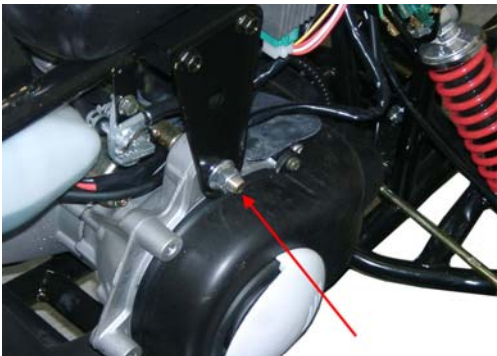

**4-2 ENGINE FUEL SYSTEM**

**4-2-1 TROUBLESHOOTING**

ENGINE DOES NOT STARTIN

- NO FUEL IN TANK
- NO FUEL TO CYLINDER
- TOO MUCH FUEL GO INTO CYLINDER
- NO SPARK AT PLUG
- AIR CLEANER CLOGGED

ENG E IDLES UNSTEADY, STALLS OR RUNS POORLY

- IN PROPER ADJUSTMENT OF THE IDLE SPEED SCREW
- IGNITION MALFUNCTION
- FUEL/AIR MIXTURE RATIO INCORRECT
- AIR FILTER DIRTY
- INSULATOR LEAKS

LEAN MIXTURE

- FUEL TANK CAP BREATHING HOLE CLOGGED
- FUEL JET OF CARBURETOR CLOGGED
- FUEL TANK CAP BREATHING HOLE CLOGGED
- FUEL FILTER CLOGGED
- FUEL FLOW IN THE TUBE UNSMOOTHLY

## 四、ENGINE SYSTEM

JW50/90/100

---

RICH MIXTURE

- FLOAT LEVEL IN CARBURETOR TOO LOW
- FLOAT NEEDLE VALVE IN CARBURETOR FAULTY
- FLOAT LEVEL TOO HIGH
- AIR DUCT IN CARBURETOR IS CLOGGED
- AIR FILTER DIRTY

**四、ENGINE SYSTEM**

**JW50/90/100**

**4-2-2 FUEL TANK**

**REMOVAL**

Remove the seat front/rear side cover and hand/e bar assy.

Disconnect the fuel line from the carburetor.

Remove the fuel tank cap and front fender.

Unscrew the fuel tank fixed bolts.

**Note: Keep gasoline away from flames or sparks.**

**Wipe up spilled gasoline at once.**



**4-3 ENGINE LUBRICATION AND COOLING SYSTEM**

**4-3-1 ENGINE LUBRICATION SYSTEM**

The pump gears of the oil pump are driven by the engine crankshaft. The pump gears rotate the plunger shaft in the oil pump.

This shaft forwards the lubricating oil into the crankcase to mix with the air-fuel mixture flow evenly.

The oiled mixture lubricates the cylinder inner wall, piston surface and piston rings.

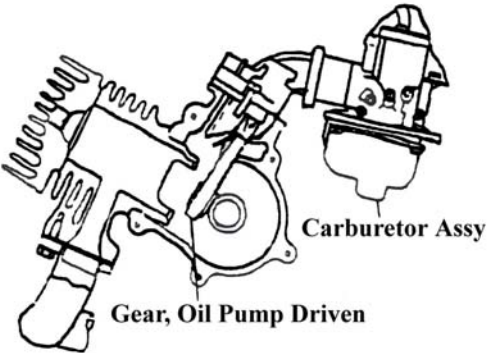

**4-3-2 COOLING SYSTEM**

The cooling fan is on the right side of the engine.

Cool air is forced to flow through cylinder fins and cylinder head. In this way the cylinder and piston will not overheat.

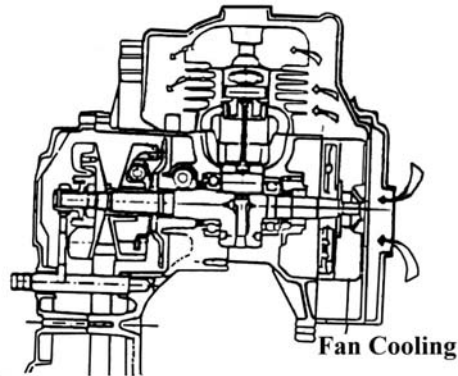

## 四、ENGINE SYSTEM

### JW50/90/100

#### 4-3-3 OIL PUMP REMOVAL

Remove the front fender rod (L), fan cover  
assy, cooling fan, generator.  
Disconnect the oil tube of oil pump  
(intake & output.)  
Remove the oil pump control cable.  
Remove the setting bolt of oil pump.  
Remove the oil pump.



#### 4-3-4 OIL PUMP INSPECTION

Check the O-ring, gear & seal for wear or  
any damage.

**NOTE: Do not disassembly the oil  
pump body to prevent and  
damage.**

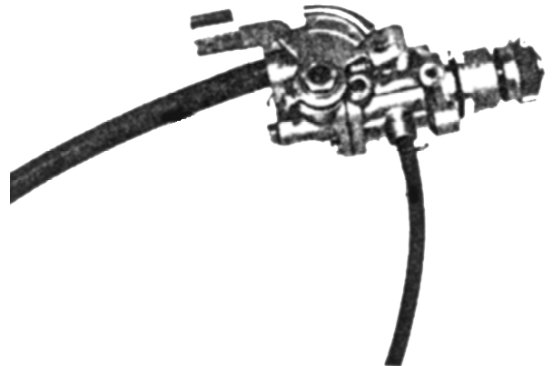

#### 4-3-5 OIL PUMP INSTALLATION

Coating some oil on the O-ring.  
Install the oil pump onto the crankcase.

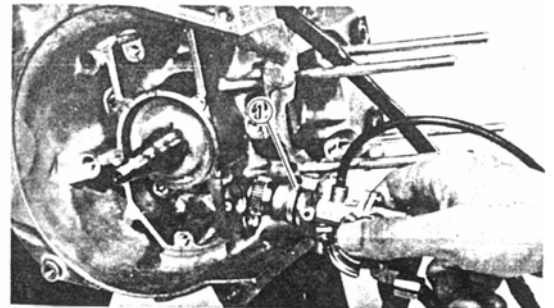



## 四、ENGINE SYSTEM

JW50/90/100

Connect the oil tube.  
Connect the oil pump control cable and adjust the clearance.



### 4-3-6 RELEASE THE AIR OF OIL PUMP

Loosen the drain screw.  
Let the oil drain out smoothly then tighten the screw.

**NOTE: If the oil can not drain out smoothly, it means some air is still in the oil pump.**

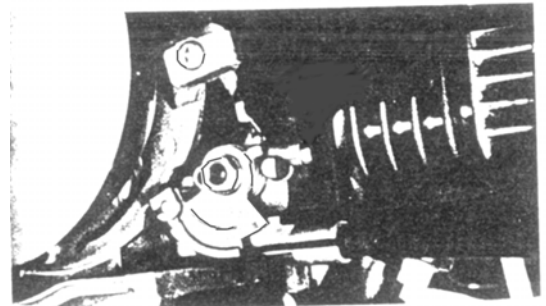

### 4-3-7 TROUBLESHOOTING

LACKING OIL SUPPLY TO ENGINE →

- THE OIL LEVEL IN OIL TANK IS TOO LOW
- OIL TUBES WERE NOT FIXED WELL
- OIL HAS LEAKED FROM TUBE ENDS
- OIL TUBES WERE BROKEN
- OIL TUBES WERE CLOGGED
- OIL PUMP DOES NOT FUNCTION

ALWAYS INSUFFICIENT OIL LEVEL IN OIL TANK →

- EXTERNAL OIL LEAKS
- WORN CYLINDER HEAD GASKET
- WORN PISTON RINGS

## 4-4 ENGINE COMBUSTION SYSTEM

### 4-4-1 TROUBLESHOOTING

LOW COMPRESSION →

- CYLINDER HEAD

## 四、ENGINE SYSTEM

JW50/90/100

---

- HEAD GASKET LEAKING OR DAMAGED  
WARPED OR CRACKED CYLINDER HEAD  
➤ CYLINDER OR PISTON RINGS WORN OUT
- HIGH COMPRESSION —————➤ EXCESSIVE CARBON BUILD-UP ON PISTON  
HEAD OR IN COMBUSTION CHAMBER
- EXCESSIVE NOISE —————➤ PISTON AND CYLINDER WORN OUT  
➤ EXCESSIVE CARBON BUILD-UP
- EXCESS SMOKE —————➤ CYLINDER OR PISTON RINGS WORN OUT  
➤ IMPROPER INSTALLATION OF PISTON RINGS  
➤ PISTON OR CYLINDER WALL SCORED OR  
SCRATCHED
- OVERHEATING —————➤ EXCESSIVE CARBON BUILD-UP ON THE  
PISTON OR COMBUSTION CHAMBER  
➤ FAULTY ENGINE COOLING SYSTEM  
(FAN, CYLINDER COVER.....)  
➤ OIL SUPPLY IS OUT OF ORDER  
➤ WRONG IGNITION TIMING

### 4-4-2 CYLINDER HEAD REMOVAL

- Remove the seat and rear fender.
- Remove the exhaust pipe.
- Remove the spark plug cap.
- Disconnect the wire.
- Remove the engine out of the chassis.
- Disassemble the air cleaner and carburetor.



## 四、ENGINE SYSTEM

### JW50/90/100

---

Remove the spark plug.  
Remove the setting bolts of cylinder head.  
Remove the cylinder head.



#### **CYLINDER REMOVAL**

Remove the cylinder head.  
Remove the cylinder.  
Remove the cylinder gasket.

**NOTE: Clean all the material of cylinder gasket with a scraper.**

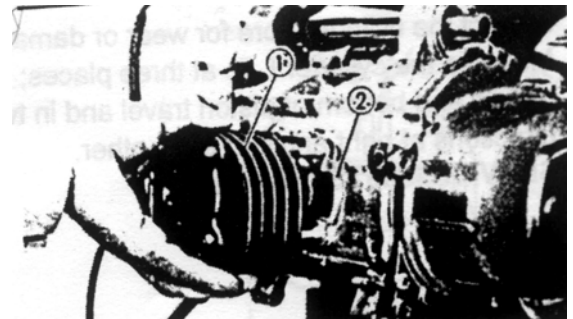

#### **PISTON REMOVAL**

Remove the piston pin clip.  
**NOTE: Do not let the clip fall into the crankcase.**

Remove the piston pin.  
Remove the piston.

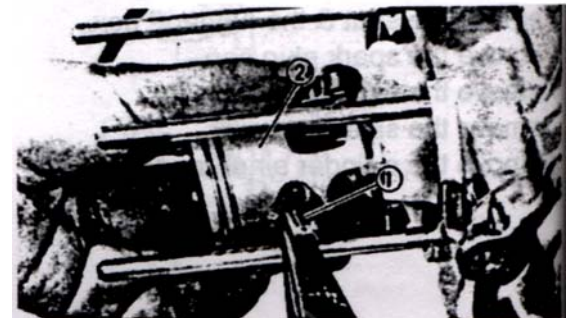

**四、ENGINE SYSTEM**

**JW50/90/100**

**4-4-3 CYLINDER HEAD INSPECTION**

Cylinder head flatness inspection.

**SERVICE LIMIT: 0.03 mm**

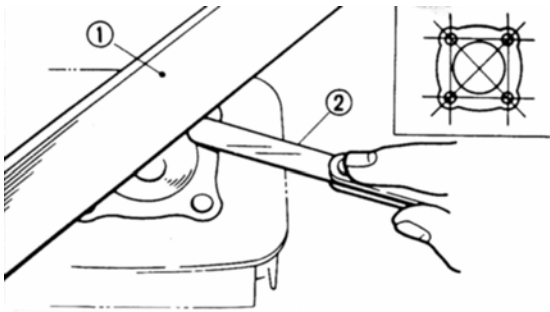

**4-4-4 CYLINDER INSPECTION**

Inspect the cylinder bore for wear or damage.

Measure the cylinder I.D. at three places; top, middle and bottom of piston travel and in two directions at right angle to each other.

**SERVICE LIMITS: 40.5 mm**



Cylinder block flatness inspections:

**SERVICE LIMITS: 0.03 mm**

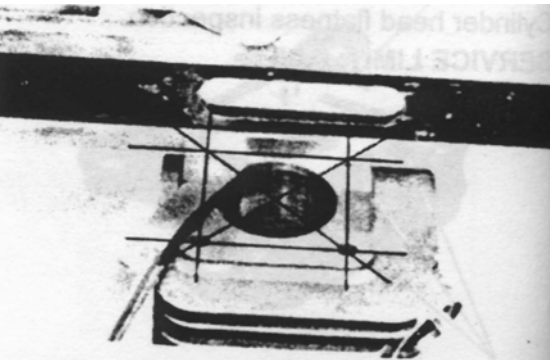

**四、ENGINE SYSTEM**

**JW50/90/100**

Calculate the piston-to-cylinder clearance.  
**SERVICE LIMITS:0.1 mm**

Calculate the taper and out of round.  
**SERVICE LIMITS:**  
**Out of round: 0.004 mm**

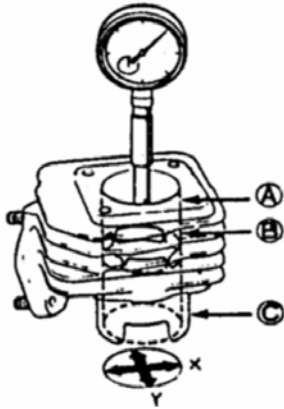

**4-4-5 PISTON / PISTON RING INSPECTION**

Remove the piston rings  
Clean the grooves for carbon deposit completely.

**NOTE: Do not damage the piston ring during removal.**



Measure piston pin bore O.D, at a point 10 mm from the bottom.  
**SERVICE LIMITS: 39.95~39.97 mm**

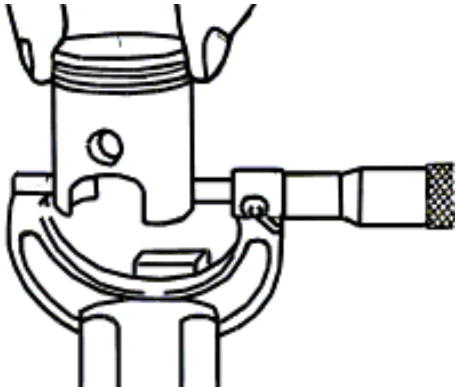

**四、ENGINE SYSTEM**

**JW50/90/100**

Measure piston pin bore I.D. in two directions at right angle to each other.  
**SERVICE LIMITS: 9.995~10 mm**



Measure the piston pin O.D. at the front, center and rear and in to directions across from each other.  
**SERVICE LIMIT: 9.9 mm**



Connecting rod small end inspections:  
**SERVICE LIMIT: 14.05 mm**

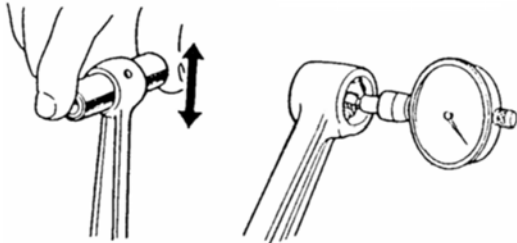

Insert each piston ring into cylinder with the piston and measure the ring end gap in the cylinder to a point 10 mm (0.04 in) from the bottom.

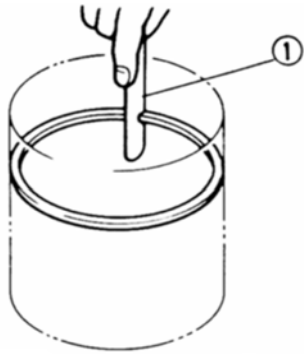

**四、ENGINE SYSTEM**

**JW50/90/100**

**PISTON RING INSTALLATION**

Clean the piston ring grooves thoroughly.  
Install the piston ring.

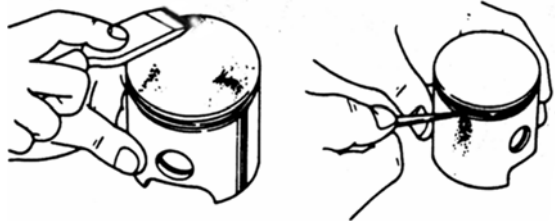

**NOTE:**

- ✕ Avoid piston and piston ring damage during installation.
- ✕ All ring should be installed with the mark facing up.

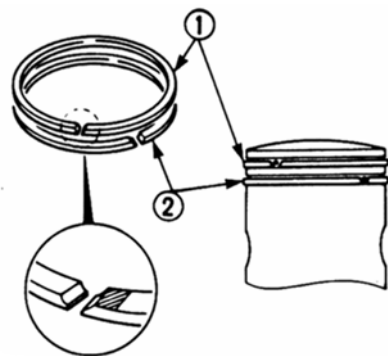

**4-4-6 PISTON INSTALLATION**

Install the piston, piston pin and new piston pin clips.

**NOTE:**

- ✕ Piston the “EX” mark on the exhaust side.
- ✕ Do not let the piston pin clip fall into the crankcase.



## 四、ENGINE SYSTEM

### JW50/90/100

#### 4-4-7 CYLINDER / CYLINDER HEAD

Install the cylinder gasket.  
Coat the cylinder and piston ring with the engine oil.  
Install the cylinder.  
Install the cylinder head  
Tighten the cylinder mounting bolts  
The torque is 1.4~2.0kg-m

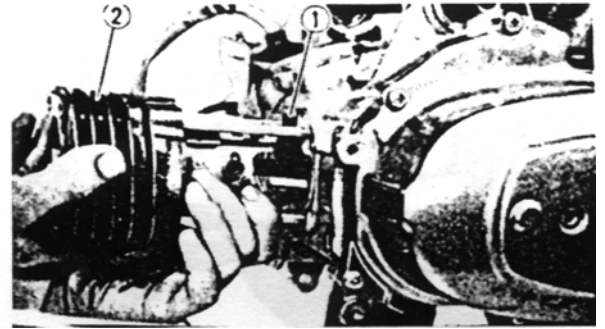

#### 4-4-8 ENGINE INSTALLATION

The installation sequence is essentially the reverse of removal.

**NOTE: Route all the wire and cable properly.**  
**Adjust the throttle cable free play.**  
**Adjust the oil pump control cable clearance.**  
**Adjust the rear brake free play.**



#### 4-5 TRANSMISSION SYSTEM

##### 4-5-1 LEFT CRANKCASE COVER

###### REMOVAL

Remove the crankcase cover.  
Remove the dowel pin.





## 四、ENGINE SYSTEM

JW50/90/100

---

Remove the kick pinion with the kick friction spring.  
Disconnect the kick start spring.

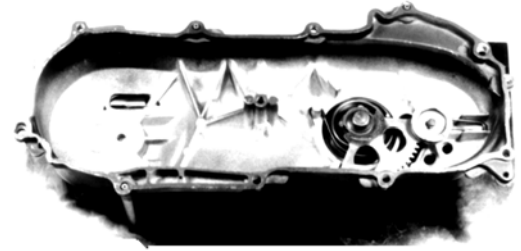

Remove the cir-clip & plate washer.  
Remove the kick spindle bush.  
Remove the spindle & the spring.



Remove the O-ring.  
Remove the setting nut of clutch outer.

**四、ENGINE SYSTEM**

**JW50/90/100**

Remove the clutch outer & driven pulley.  
Remove the drive belt.

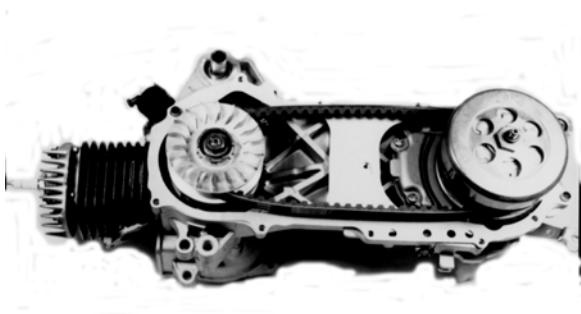

Remove the setting nut of driver face.

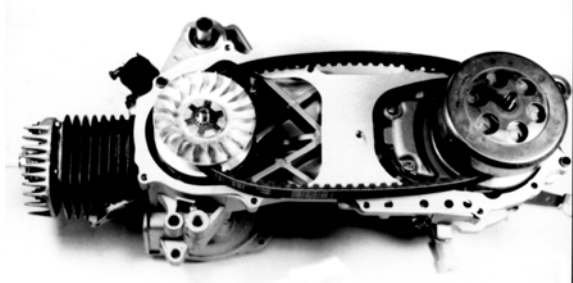

Remove the conical spring washer & the one way clutch.  
Remove the claw washer, driver face & plat washer.

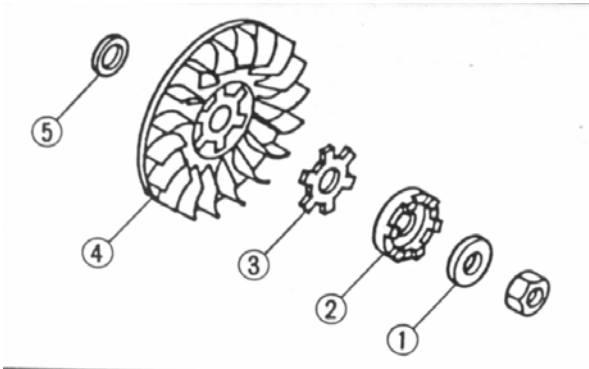

**四、ENGINE SYSTEM**

**JW50/90/100**

Remove the movable drive face & collar.

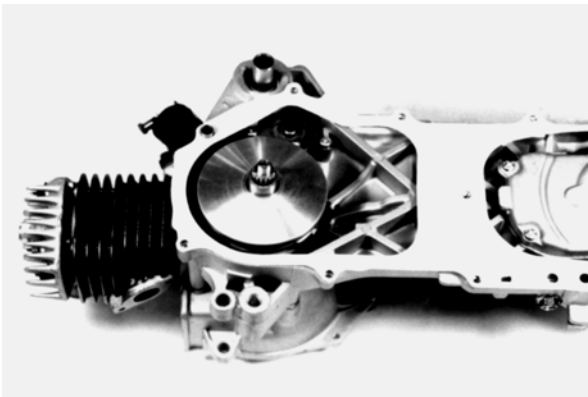

**4-5-2 START CLUTCH REMOVAL**

Remove the starter clutch & starter wheel.  
Remove the gear boss.  
Remove the plat washer.

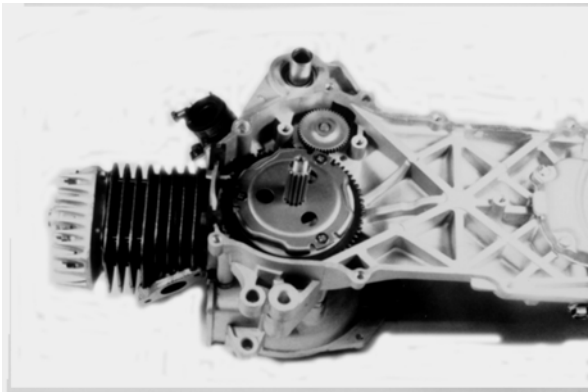

Remove the idle gear plate.  
Remove the idle gear.



**四、ENGINE SYSTEM**

**JW50/90/100**

**4-5-3 DRIVEN BELT INSPECTION**

Inspect the belt for crack wear or any damage measure the width of belt.

**SERVICE LIMIT:14.6 mm**

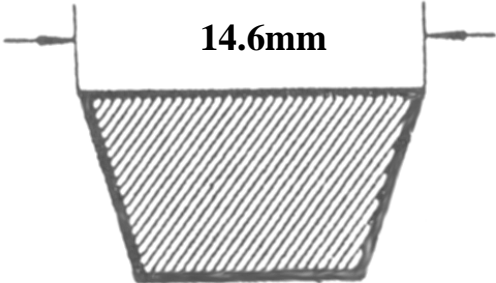

**4-5-4 WEIGHT ROLLER INSPECTION**

Measure the weight roller O.D.

**SERVICE LIMIT:14.5 mm**

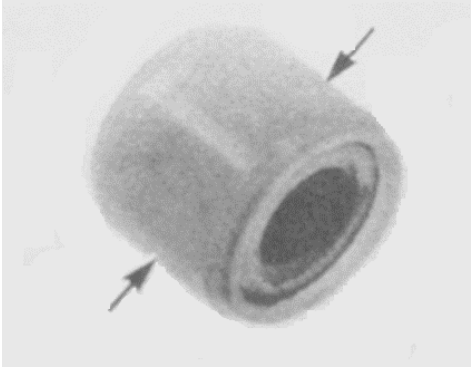

**4-5-5 MOVABLE DRIVEN FACE INSPECTION**

Measure the movable driven face I.D.

**SERVICE LIMIT:18.10 mm**

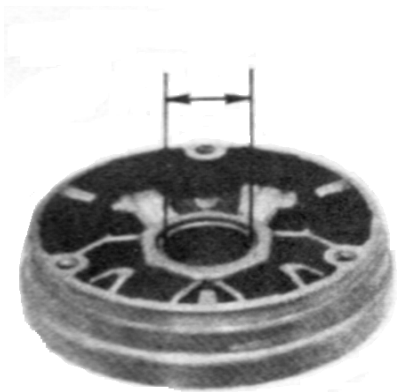

**四、ENGINE SYSTEM**

**JW50/90/100**

---

**4-5-6 BOSS OF DRIVEN FACE  
INSPECTION**

Measure the boss I.D.  
**SERVICE LIMIT: 17.90 mm**

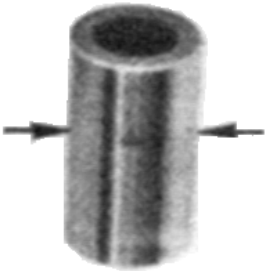

**4-5-7 CLUTCH OUTER INSPECTION**

Measure clutch outer I.D.  
**SERVICE LIMIT: 112 mm**

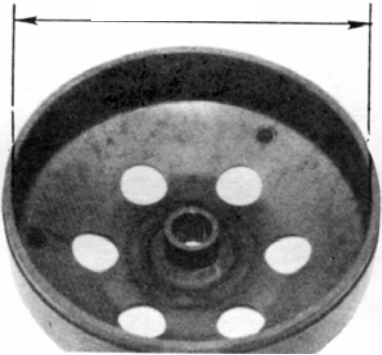

**4-5-8 CLUTCH LINING INSPECTION**

Measure the lining thickness.  
**SERVICE LIMIT: 1 mm**

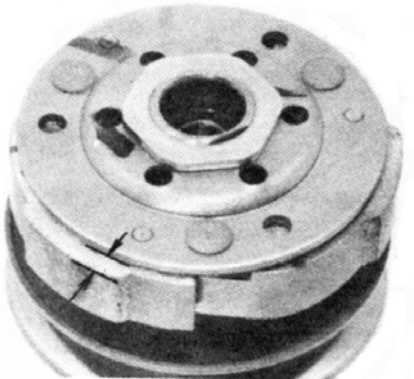

## 四、ENGINE SYSTEM

JW50/90/100

---

### 4-5-9 DRIVEN PULLEY DISASSEMBLY

Fix the driven pulley in a compressor.  
Remove the special nut  
Release the compressor.  
Remove the driven plat assy.

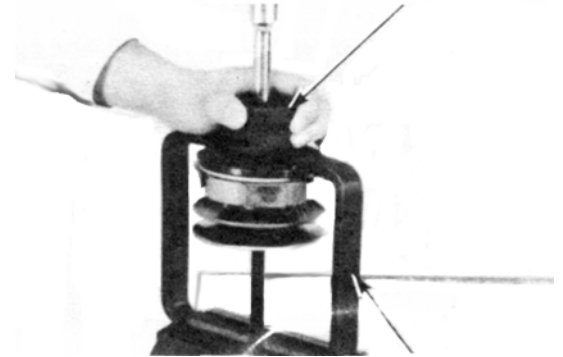

### 4-5-10 DRIVEN FACE SPRING INSPECTION

Measure the spring free leant.



### DRIVEN FACE INSPECTION

Measure the drive face O.D.

**SERVICE LIMIT: 32.94 mm**

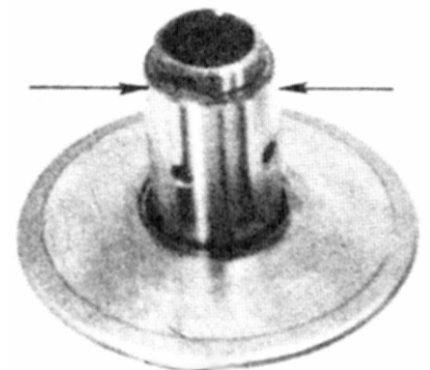

**四、ENGINE SYSTEM**

**JW50/90/100**

**4-5-11 MOVABLE DRIVEN FACE  
INSPECTION**

Measure the movable driven face I.D.  
**SERVICE LIMIT: 33.06 mm**

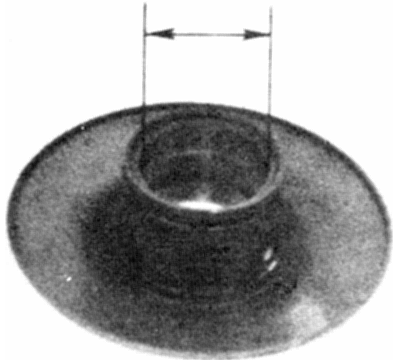

**4-5-12 FINAL TRANSMISSION GEAR  
REMOVAL**

Drain the gear oil  
Remove the mission cover.

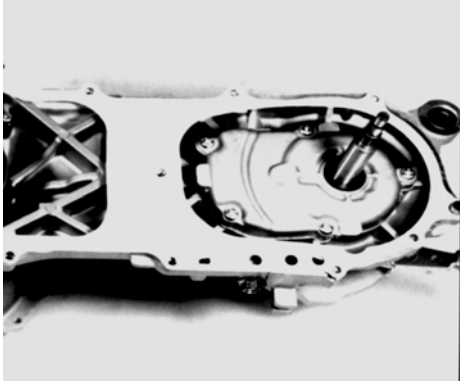

Remove mission cover gasket & dowel pin.  
Remove final shaft & final gear.  
Remove counter shaft.



## 四、ENGINE SYSTEM

JW50/90/100

### 4-5-13 FINAL GEAR TRANSMISSION GEAR INSPECTION

Inspect the gears & shafts for wear or damage.

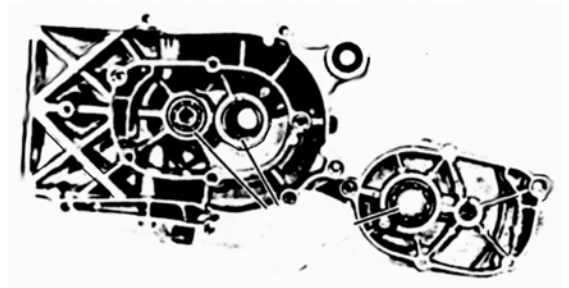

### 4-6 CRANKSHAFT / CRANKCASE

#### 4-6-1 CRANKCASE REMOVAL

Remove the crankcase setting bolts.

Remove the right crankcase from the left crankcase by using a pulley.

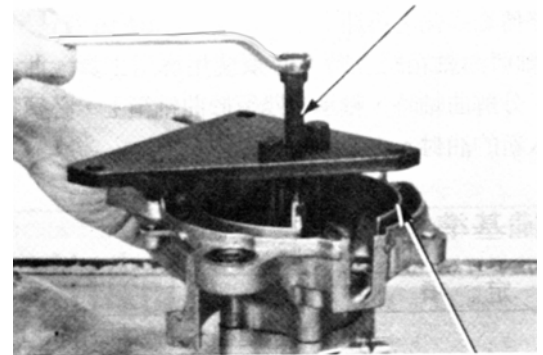
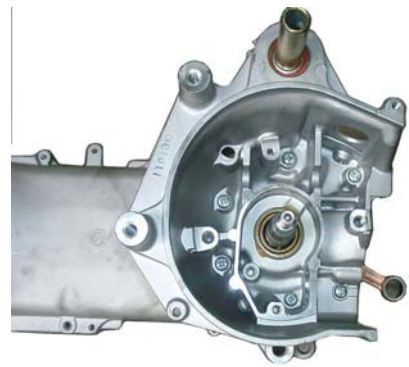



## 四、ENGINE SYSTEM

### JW50/90/100

---

Remove the crankcase from the left crankcase by using a pulley.

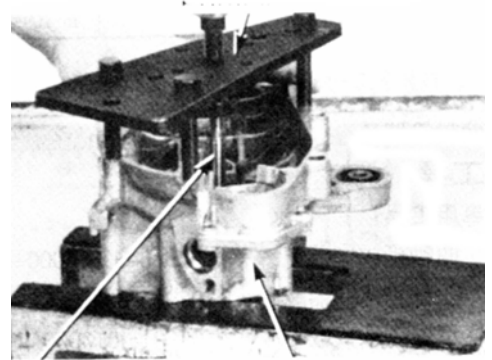

Remove the bearing of crankcase by using a bearing pulley.

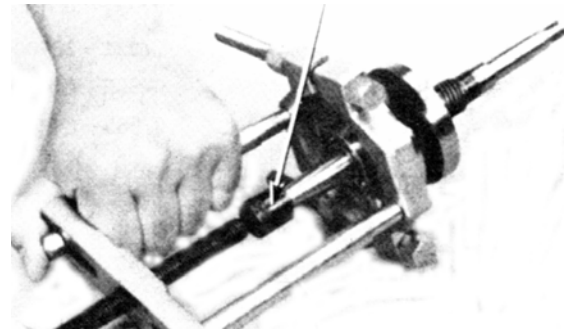

#### 4-6-2 CRANKSHAFT INSPECTION

Measure the connecting rod big end side clearance with a feeler gauge.

**SERVICE LIMIT:0.2~0.5 mm**



## 四、ENGINE SYSTEM

### JW50/90/100

Measure the connecting rod big end radial clearance at two different point across from each other.

**SERVICE LIMIT: 0.4~0.8 mm**

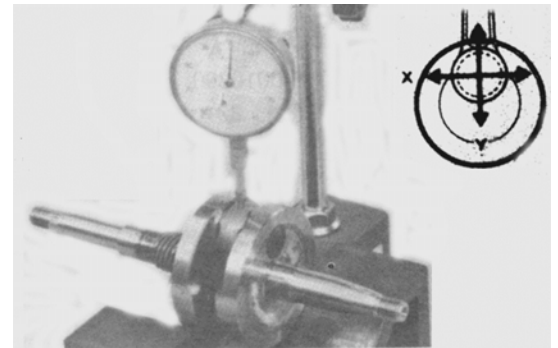

Place the crankshaft on a stand or V-blocks and measure the run out using a dial gauge.

Actual bend is 1/2 of total indicator reading.

**SERVICE LIMIT: 0.03 mm**

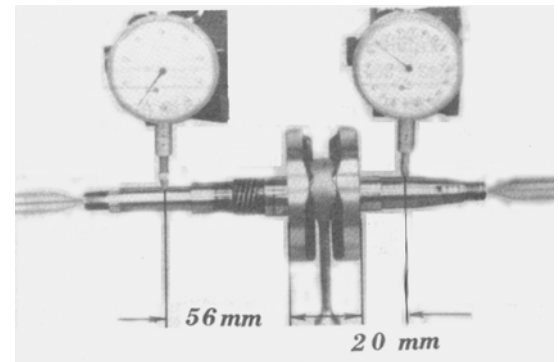

Check the crankshaft bearing play.  
If they are noisy or have recessive play, replace a new one.

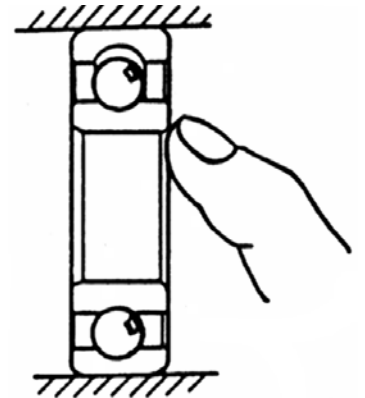

**四、ENGINE SYSTEM**

**JW50/90/100**

**4-6-3 CRANKCASE INSTALLATION**

Install the crankshaft bearing into the left crankcase.

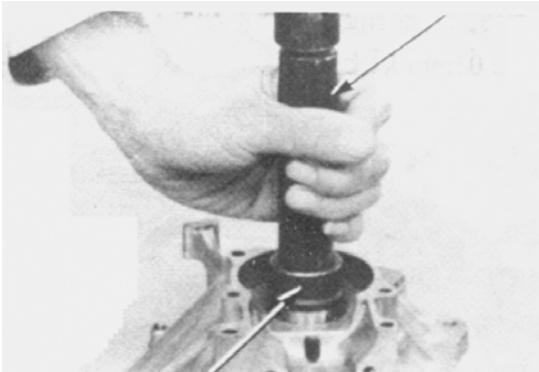

Install the crankshaft bearing into the right crankcase.

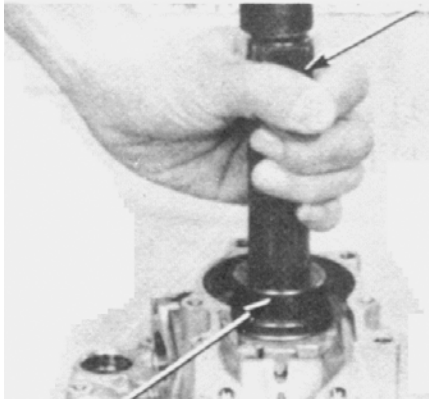

Install the crankshaft into the left crankcase.

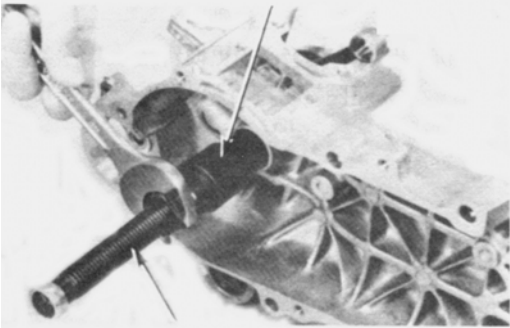

**四、ENGINE SYSTEM**

**JW50/90/100**

Install the oil seal into the left crankcase.

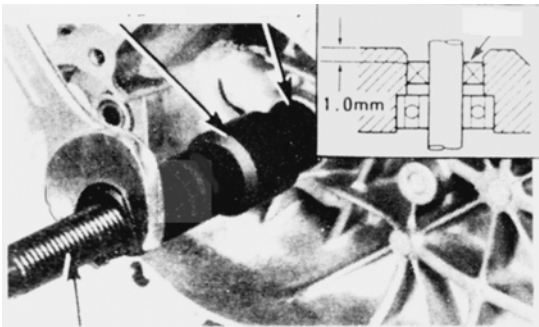

Install the dowel pins.

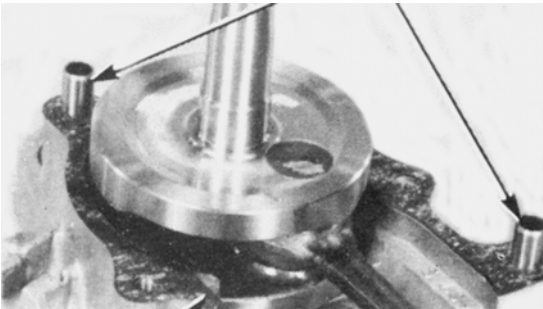

Install the right crankcase.

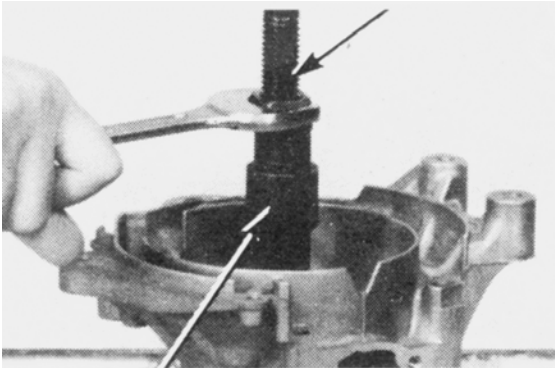

**四、ENGINE SYSTEM**

**JW50/90/100**

Install the oil seal into the right crankcase.

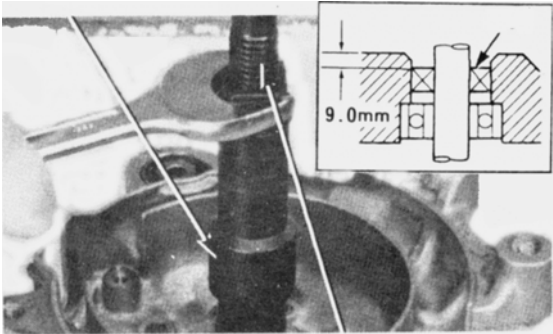

Install the setting bolts of crankcase.  
**TORQUE:0.7~1.0 kg-m**

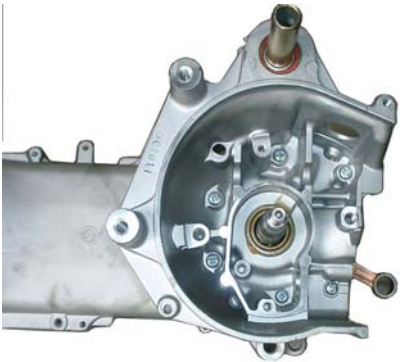

**4-7 A.C.G ENERATOR**

**4-7-1 A.C.G ENERATOR REMOVAL**

Remove front fender rod (L) and fan cover assy.



## 四、ENGINE SYSTEM

### JW50/90/100

---

Remove the cooling fan setting bolts.  
Remove the cooling fan.



Remove the fly wheel setting nut by using  
a “Y” fixer.



Remove the fly wheel by using a puller.



## 四、ENGINE SYSTEM

### JW50/90/100

Disconnect the wires of A.C.G.

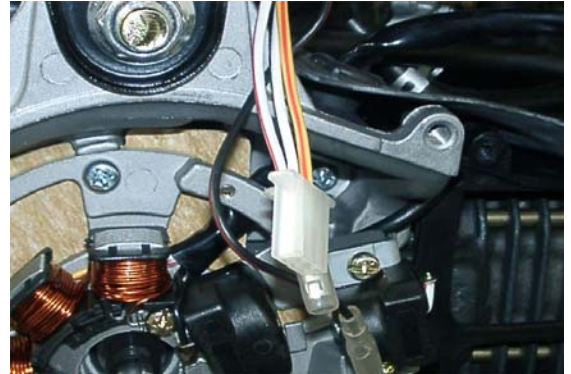

Remove the A.C.G. setting bolts.  
Remove the A.C.G.



#### 4-7-2 A.C.G. INSTALLATION

The installation sequence is essentially the reverse of removal.



## 五、CARBURETOR SYSTEM

JW50/90/100

### 5-1 CARBURETOR REMOVAL

Remove the air cleaner.

Disconnect the fuel line and auto-choke electric wire.

Unscrew the intake pipe mounting bolts at the carburetor then remove the carburetor.

**NOTE: Turn fuel tap in off position**



Loose the carburetor cap.

Remove the throttle valve from the carburetor.



Remove the throttle valve from the throttle cable.

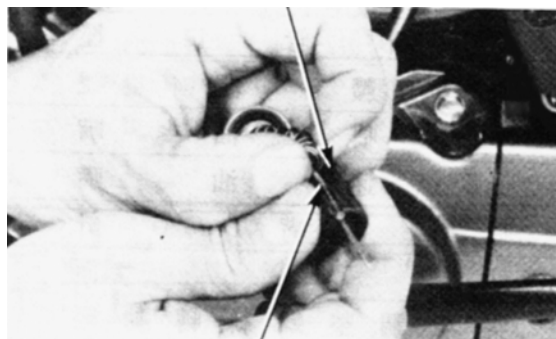



**五、 CARBURETOR SYSTEM**

**JW50/90/100**

**THROTTLE VALVE DISASSEMBLY**

Remove the retainer and take out the jet needle clip from the throttle valve.

**INSPECTION**

Check the throttle valve and the jet needle surface of dirt, scratches or wear.



**5-2 STARTER PLUNGER INSPECTION**

Check the starter plunger wire for continuity.

**STANDARE : UNDER 10**



Remove the carburetor and let it cool down by nature for thirty minutes.

Check the current of air route as show.

**GOOD : CHECKLESS**

**NG : CHECKED**

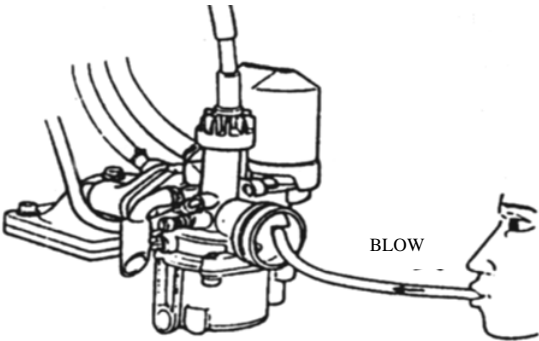

**五、 CARBURETOR SYSTEM**

**JW50/90/100**

Connect a full charged battery to the starter  
plunger wire for five minutes.  
Check the current of route as show.

**GOOD : CHECKED**

**NG : CHECKLESS**

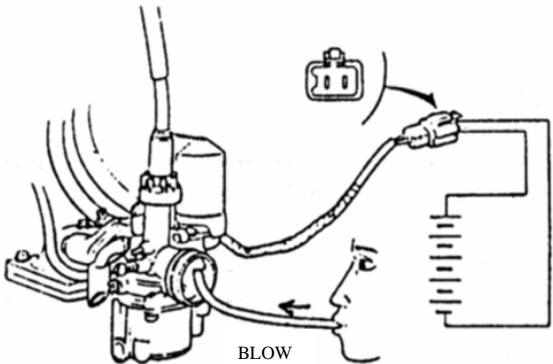

**5-3 FLOAT CHAMBER DISASSEMBLY**

Remove the setting screws.  
Remove the chamber cap.



Remove the float setting bolt.  
Remove the float pin.  
Remove the float.  
Remove the float valve.



## 五、CARBURETOR SYSTEM

### JW50/90/100

---

Remove the main jet, slow jet, needle seat & air screw.

Clean all the jet & all the hole by using high pressure air.



### 5-4 FUEL HEIGHT INSPECTION

Measure the height by using a gauge.

**STANDARD: 18.5 mm**



### 5-5 CARBURETOR INSTALLATION

The installation sequence is essentially the reverse of remove.



## 五、CARBURETOR SYSTEM

### JW50/90/100

---

Adjust the clearance of the throttle valve cable.

Adjust the air screw.

**STANDARD** :  $1\frac{1}{2} \pm \frac{1}{2}$  round

Adjust the idle speed.

**STANDARD** :  $1800 \pm 100$ rpm

### 5-6 REED VALVE

#### 5-6-1 REED VALVE REMOVAL

Remove the carburetor.

Remove the intake pipe.

Remove the reed valve.



#### 5-6-2 REED VALVE INSPECTION

Measure the height of reed valve stopper.

Check the flatness of reed valve.

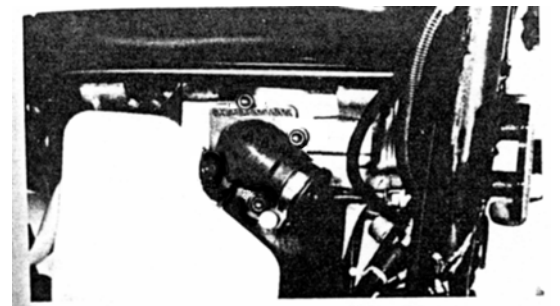

## 五、CARBURETOR SYSTEM

JW50/90/100

---

### 5-6-3 REED VALVE INSTALLATION

The installation sequence is essentially the reverse of removal.



## 六、FRAME SYSTEM

JW50/90/100

### 6-1 FRONT WHEEL AND STEERING SYSTEM

#### 6-1-1 DRAWING OF FRONT WHEELS AND STEERING SYSTEM PARTS

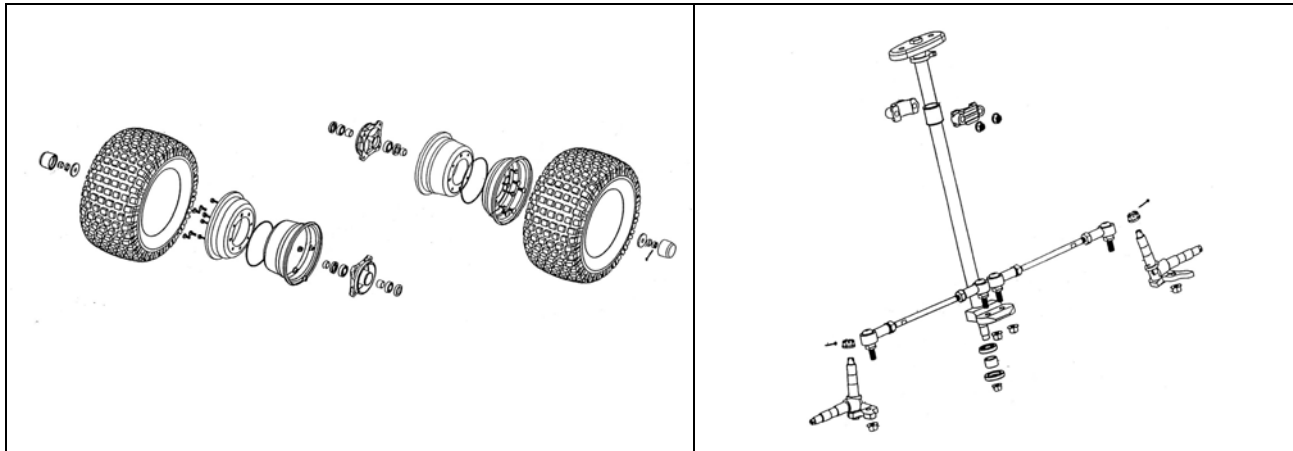

#### 6-1-2 TROUBLESHOOTING

- |                        |   |
|------------------------|---|
| HARD STEERING          | ➤ FAULTY TIRE                           |
|                        | ➤ STEERING SHAFT HOLDER TOO TIGHT       |
|                        | ➤ INSUFFICIENT TIRE PRESSURE            |
|                        | ➤ FAULTY STEERING SHAFT                 |
|                        | ➤ DAMAGED STEERING SHAFT BEARING        |
| FRONT WHEEL WOBBLING   | ➤ FAULTY TIRE                           |
|                        | ➤ WORN FRONT BRAKE DRUM BEARING         |
|                        | ➤ BENT RIM                              |
|                        | ➤ AXLE NUT NOT TIGHTENED PROPERLY       |
| BRAKE DRAG             | ➤ INCORRECT BRAKE ADJUSTMENT            |
|                        | ➤ STICKING BRAKE CABLE                  |
| STEERS TO ONE SIDE     | ➤ BENT TIE RODS                         |
|                        | ➤ WHEEL INSTALLED INCORRECTLY           |
|                        | ➤ UNEQUAL TIRE PRESSURE                 |
|                        | ➤ BENT FRAME                            |
|                        | ➤ WORN SWING ARM PIVOT BUSHINGS         |
| POOR BRAKE PERFORMANCE | ➤ BRAKE SHOES WORN                      |
|                        | ➤ WORN BRAKE DRUM                       |
|                        | ➤ BRAKE LININGS OILY, GREASY OR DIRTY   |
|                        | ➤ IMPROPER BRAKE ADJUSTMENT             |
| FRONT SUSPENSION NOISE | ➤ LOOSE FRONT SUSPENSION FASTENERS      |
|                        | ➤ BINDING SUSPENSION LINK               |
| HARD SUSPENSION        | ➤ FAULTY FRONT SWING ARM BUSHINGS       |
|                        | ➤ IMPROPERLY INSTALLED FRONT SWING ARMS |
|                        | ➤ BENT FRONT SHOCK ABSORBER ROD         |

## 六、FRAME SYSTEM

JW50/90/100

SOFT SUSPENSION

- WEAK FRONT SHOCK ABSORBER SPRINGS
- WORN OR DAMAGED FRONT SWING ARM BUSHINGS

### 6-1-3 HANDLE BAR REMOVAL AND INSTALLATION

#### REMOVAL

Remove the handle cover and protect foam.



Remove the throttle cable on the right level.



Remove the front brake cable. Please note that if you want to take the front brake cable apart, the gap of adjustable screw of brake needs to aim at the gap of right level.



## 六、FRAME SYSTEM

### JW50/90/100

---

Loose the screw of right level and  
remove the right level to the fuel tank.



Remove the right grip.  
Take right level apart from handle bar.



Remove the rear brake cable and link  
switch electric wire of rear brake light.





## 六、FRAME SYSTEM

### JW50/90/100

---

Remove the left handle switch and link electric wire.



Loose the screw of left level and remove left level to fuel tank.  
Remove the left grip.



Remove the handle cover stay.  
Remove the L/R handle cover holder.



## 六、FRAME SYSTEM

### JW50/90/100

Remove the handle bar.



### INSTALLATION

Installation is the reverse order of removal.

Please pay attention to following items when you assemble L/R level:

- A. There are one point of orientation separately located on the left and the right of handle bar.
- B. When you assemble left level, the gap of left level must aim at orientation of handle bar (as drawing B).
- C. When you assemble right level, the gap of right level must aim at orientation of handle bar (as drawing C).

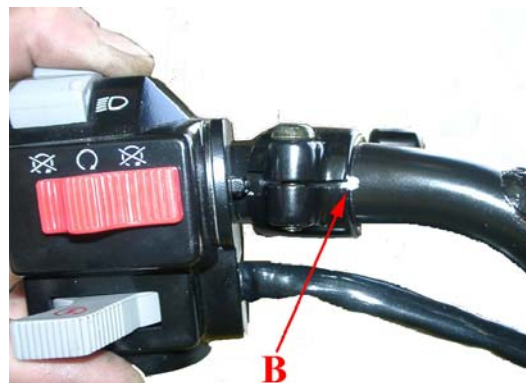

## 六、FRAME SYSTEM

JW50/90/100

### 6-1-4 FRONT WHEEL

#### REMOVAL

Raise the front wheels off the ground by placing a block under the frame.

Remove the front wheel nuts, washers and wheels.

#### INSTALLATION

Install and tighten the four-wheel nuts

**TORQUE:3.5~4.0kgf-m**

Remember to put a cotter pin in the castle nut.



### 6-1-5 FRONT BRAKES

#### FRONT BRAKE INSPECTION

Remove the front wheel.

Remove the brake drum.

Measure the brake lining thickness.

**The minimum limit: 1.5 mm**

If they are thinner than the minimum limit, replace the brake linings.



Measure the brake drum inner diameter.

**The maximum limit : 86 mm**



## 六、FRAME SYSTEM

### JW50/90/100

---

Turn the inner race of each bearing with the fingers.  
The bearings should turn smoothly and quietly.  
If the race does not turn smoothly or quietly, remove and discard the bearings.



#### **BRAKE PANEL REMOVAL**

Disconnect the brake cable from the brake arm.  
Remove the brake panel from the knuckle.



Remove brake arm and cam.  
Remove return spring.  
Remove felt seal.



## 六、FRAME SYSTEM

### JW50/90/100

---

#### INSTALL BRAKE PANEL

Apply grease to the brake cam and anchor pin and install the cam in the brake panel.

Soak the felt seal in the engine oil and install the seal on the brake cam.

Install the brake arm on the cam by aligning the punch mark and the groove on the cam.

Tighten the brake arm bolt and nut.

**TORQUE:4-7Nm**



Install the brake panel on the knuckle.  
Connect the brake cable to the brake arm.  
Install the brake arm cover.  
Tighten the screws securely.  
Position the brake shoes in their original location and install the brake shoe spring.  
Install the brake drum and the front wheel.  
Install the castle nut and cotter pin.



## 六、FRAME SYSTEM

JW50/90/100

### 6-1-6 STEERING SYSTEM

#### REMOVAL OF KNUCKLE AND TIE-ROD

Remove the front wheels and brakes panel.

Remove the four self lock nuts from the tie-rod ball joints and take off the two tie-rods.



Take the rubber cap off the knuckle and remove the cotter pin on the knuckle. Unscrew the castle nut and remove the knuckle.



#### TIE-ROD INSPECTION

Inspect the tie-rod for damage or bending.

Inspect the ball joint rubbers for damage, wear or deterioration.

Turn the ball joints with fingers. The ball joints should turn smoothly and quietly.



## 六、FRAME SYSTEM

### JW50/90/100

#### KNUCKLE INSPECTION

Inspect the knuckle for damage or cracks.

Measure the knuckle outer diameter.

Upper minimum limit :  $\varphi$  15.40 mm

Lower minimum limit :  $\varphi$  16.90 mm



#### KNUCKLE BUSHING INSPECTION

There are two bushings in the sleeve of the front swing arm, the upper and lower bushing.

Check the knuckle bushings for wear or damage.

Measure the inner diameter of the bushings.

Upper minimum limit :  $\varphi$  15.60 mm

Lower minimum limit :  $\varphi$  17.10 mm

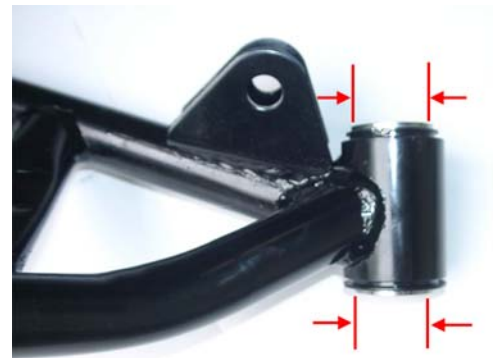

#### STEERING SHAFT REMOVAL

Remove the handle bar and handle bar cover.

Remove the front side cover.

Unscrew the steering shaft fixing nut from the bottom of the shaft.

Pull steering shaft carefully.



## 六、FRAME SYSTEM

JW50/90/100

---

### SLEEVE INSPECTION

Remove the steering shaft.  
Remove the sleeve from the shaft.  
Inspect the sleeve for damage or wear,  
replace if necessary.  
Measure the sleeve inner diameter.



### STEERING SHAFT INSPECTION

Inspect the steering shaft for damage or  
cracks.  
Measure the steering shaft outer diameter  
in the location of the sleeve.



### STEERING SHAFT BEARING INSPECTION

The bearing is on the front part of frame.  
Turn the shaft bearing by hand.  
The bearing should turn smoothly and  
quietly.  
Also check the bearing outer race  
fitment in the holder.  
Replace the bearing if necessary.





## 六、FRAME SYSTEM

JW50/90/100

### INSTALLATION OF STEERING SHAFT

Install the steering shaft with the bushing.  
Apply grease to the bushing.  
Install the bushing holder and tighten the nuts.

**TORQUE : 2.0~2.2kgf-m**



Install the steering shaft nut and tighten it.

This nut is on the bottom side of the steering shaft.

**TORQUE : 4.5~5.0kgf-m**



### INSTALLATION OF TIE-ROD

Install the ball joint with “L” mark on the steering shaft side.

Install the tie-rod with the mark on the wheel side.



Set the distance between the ball joints at 278 mm.

This is a temporary setting.



## 六、FRAME SYSTEM

### JW50/90/100

#### INSTALLATION OF KINGPIN

Use grease to the knuckle lower dust seal lips and install it.

Pump grease to the bushing and install the knuckle.

Tighten the knuckle nut, the setting torque is 3.0~4.0kgf-m

Fix the waterproof rubber cap.

Set the temporary distance 278 mm between the ball joints.

Install the tie-rod and tighten the nuts.

The setting torque :3.5~4.0kgf-m

Install the front brake.

Install the front wheel.

Adjust the toe in by changing the distance between the ball joints on the tie rods.



## 6-2 REAR WHEELS

### 6-2-1 THE PARTS DRAWING OF REAR WHEEL ASSEMBLY

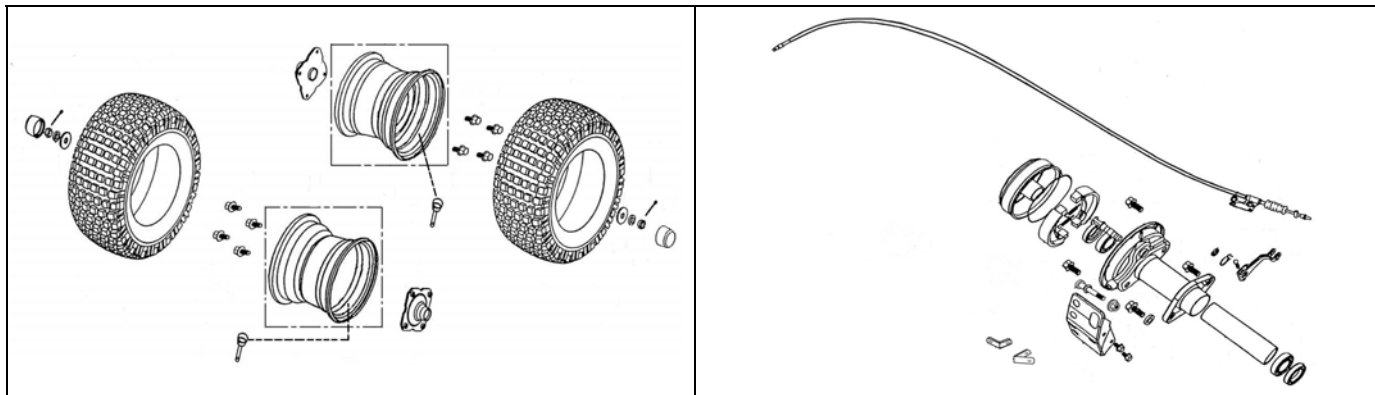

## 六、FRAME SYSTEM

JW50/90/100

### 6-2-2 TROUBLESHOOTING

**BAD BRAKE PERFORMANCE**

- BRAKE SHOES ARE WORN
- BAD BRAKE ADJUSTMENT
- BRAKE LININGS ARE OILY, GREASY OR DIRTY
- BRAKE DRUMS ARE WORN
- BRAKE ARM IMPROPERLY ENGAGED

**VIBRATION OR WOBBLE**

- AXLE IS NOT TIGHTENED WELL
- BENT RIM
- AXLE BEARINGS ARE WORN
- FAULTY TIRES
- REAR AXLE BEARING HOLDER IS FAULTY

**BRAKE DRAG**

- INCORRECT BRAKE ADJUSTMENT
- STICKING BRAKE CAM
- STICKING BRAKE CABLE

### 6-2-3 REMOVE REAR WHEEL AND REAR BRAKE

Lift the rear wheels off the ground.  
Release the cotter pin, axle nut and washer.  
Release the wheel and wheel hub.



Remove the spacer tube.  
Remove the brake drum cover.



## 六、FRAME SYSTEM

### JW50/90/100

---

Remove the axle collar and brake drum.



Check the brake lining thickness.  
The minimum limit is 2.0 mm



Check the brake drum for damage.  
Replace if necessary.  
Check the brake drum inner diameter.  
The maximum limit is 130 mm

#### 6-2-4 DRIVE MECHANISM REMOVAL AND INSPECTION

Remove the rear wheel and the rear brake  
Remove the lower part of the drive chain  
cover.



## 六、FRAME SYSTEM

### JW50/90/100

---

Remove the chain retainer clip and master link.



Disassembly the driven sprocket, axle and sprocket collar.  
Check the driven sprocket for damage or wear.



Position the rear axle in V-blocks and check the run out.  
The run out limit is 0.5 mm

Check the ease of rotation of the bearing by hand.  
The bearings should turn smoothly and quietly.  
Replace if necessary.



## 六、FRAME SYSTEM

### JW50/90/100

#### INSTALLATION

Add grease to the dust seal lips and install dust seals.  
Assemble the rear axle and the driven sprocket.



Assemble the drive chain on the driven sprocket.  
Install the master link and retaining clip.  
Note the retainer clip direction (open end to back).  
Install the complete drive chain cover.



#### 6-2-5 REAR BRAKE AND WHEEL INSTALLATION

Install the brake panel  
Add grease to the brake cam and anchor pin.  
Install the brake arm spring and oil seal.



## 六、FRAME SYSTEM

### JW50/90/100

---

Assemble the brake arm aligning the punch marks on the cam and the arm. Tighten the brake arm bolt and nut with 0.8~1.0kgf-m torque. Install the adjusters.



Install the brake shoes and springs.



Assemble the brake drum, axle collar and brake drum cover. Mount the wheel. Tighten the rear axle nut with 4.5~5.0kgf-m. Install a new cotter pin. Adjust free play of the rear brake. Adjust chain slack.



## 6-3 FENDERS AND EXHAUST PIPE

### 6-3-1 DRAWING SIDE COVER ASSY.

---

## 六、FRAME SYSTEM

JW50/90/100

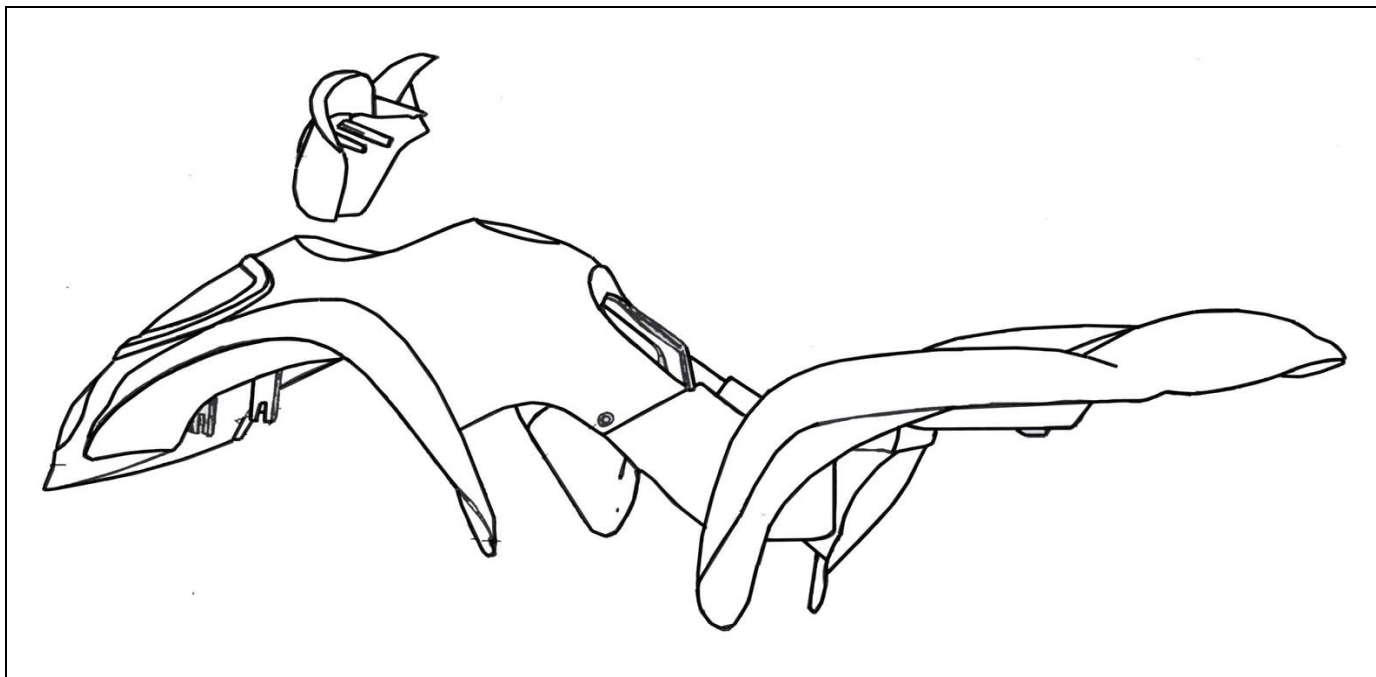

### 6-3-2 FRONT SIDE COVER REMOVAL

Remove the seat and battery.  
Disconnect the main switch and head  
light electric wire.



Remove the six screws which fitted on  
front side cover (as drawing).  
Remove the front side cover.





## 六、FRAME SYSTEM

### JW50/90/100

---

#### 6-3-3 REAR SIDE COVER REMOVAL

Remove the four screws which fitted on the rear side cover.

Remove the front side cover.



If you only want to take the rear side cover apart, please do followings steps:

- ✕ Remove the seat and battery.
- ✕ Remove the four screws which fitted on the side cover.
- ✕ Loose the four screws which fitted on the front side cover.
- ✕ Remove the two screws which fitted on the rear side cover.
- ✕ Push the front side cover forward and up, you will take the rear side cover apart.

#### 6-3-4 EXHAUST PIPE DRAWING

---

## 六、FRAME SYSTEM

JW50/90/100

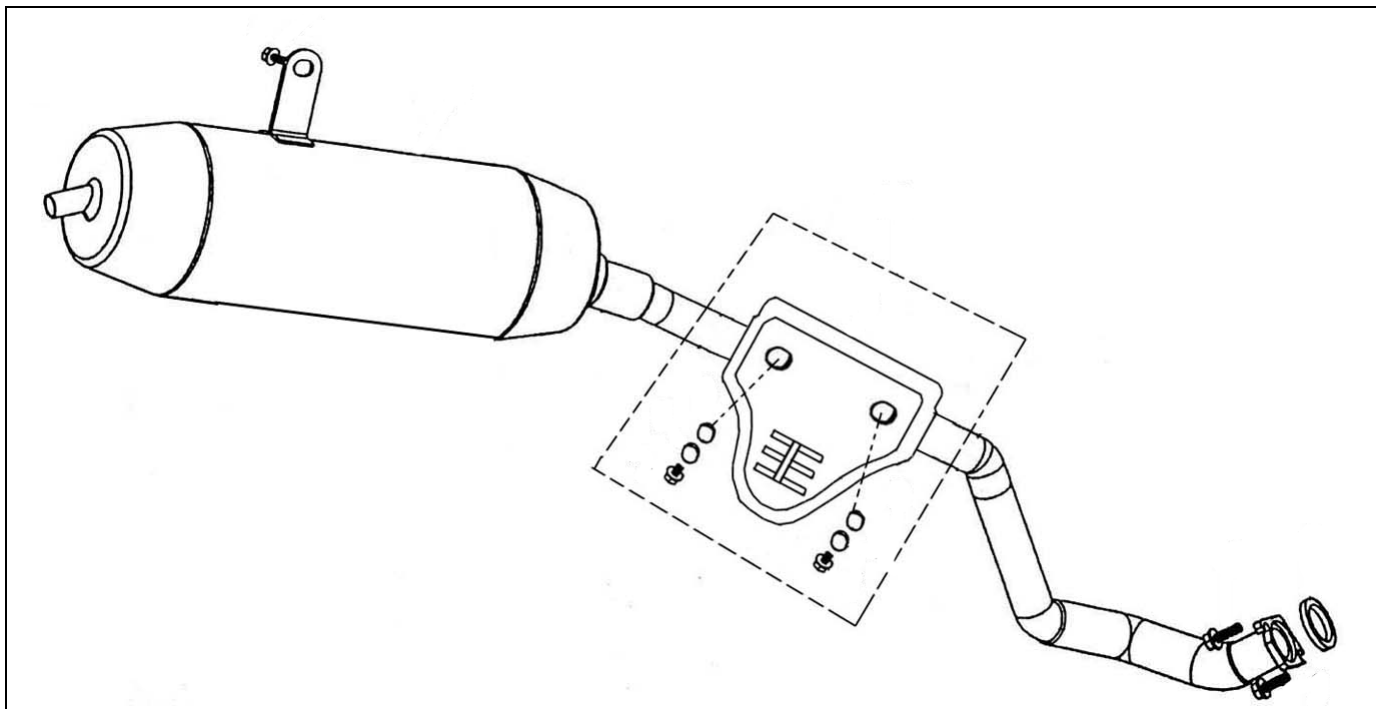

### 6-3-5 EXHAUST PIPE REMOVAL

Do not service the exhaust pipe while it is hot.

Unscrew the bolts that fix the exhaust pipe with the engine.

Remove the exhaust pipe mounting bolts besides the muffler body.  
Remove the exhaust pipe carefully.



## 六、FRAME SYSTEM

JW50/90/100

---

### 6-3-6 EXHAUST PIPE INSTALLATION

Installation is the reverse order of removal.

**TORQUE : Exhaust muffler**

**bolts 2.5~3.0kgf-m**

After installation, make sure that there are no exhaust leaks.

## 七、 ELECTRICAL SYSTEM

## 7-1 TROUBLESHOOTING

- ENGINE STARTS&STALLS —————> ➤ IMPROPER IGNITION TIMING  
➤ FAULTY SPARK PLUG
- NO SPARK AT PLUG —————> ➤ ENGINE STOP SWITCH AT “OFF”  
➤ FAULTY IGNITION COIL  
➤ FAULTY GENERATOR  
➤ FAULTY CDI UNIT  
➤ POOR CONNECTOR CONTACT:  
Between CDI and ignition coil  
Between alternator and CDI unit  
Between CDI and engine stop switch  
Between ignition coil and spark plug  
Between generator and CDI unit
- ENGINE STARTS BUT RUNS POORLY —————> ➤ IGNITION PRIMARY CIRCUIT  
Faulty generator  
Faulty CDI unit  
Faulty alternator exciter coil  
Loosened contact terminals  
Faulty ignition coil  
➤ IGNITION SECONDARY CIRCUIT  
Faulty plug  
Loosened contact spark plug cable  
➤ IMPROPER IGNITION TIMING  
Faulty generator  
Faulty CDI unit
- CHARGING SYSTEM FAILURE —————> ➤ LOOSE, BROKEN OR SHORTED WIRE  
➤ FAULTY ALTERNATOR  
➤ FAULTY IGNITION SWITCH
- ENGINE INTERMITTENT POWER —————> ➤ LOOSE BATTERY CONNECTION  
➤ LOOSE CHARGING SYSTEM CONNECTION
- STARTER MOTOR WILL NOT TURN —————> ➤ DEAD BATTERY  
➤ FAULTY IGNITION SWITCH  
➤ LOOSE OR DISCONNECTED WIRE
- STARTER MOTOR AND ENGINE TURN, —————> ➤ FAULTY IGNITION SYSTEM  
BUT ENGINE DOES NOT START ➤ ENGINE PROBLEMS  
➤ FAULTY ENGINE STOP SWITCH

## 七、 ELECTRICAL SYSTEM

### 7-2 BATTERY REMOVAL / INSTALLATION

#### BATTERY INSPECTION

Check the voltage of the battery.

**FULL CHARGE : 13.0~13.2 v**

**UNDER CHARGE : 12.3 v**



#### BATTERY REMOVAL

Remove the battery holder bolt nuts.

Disconnect the negative cable and then the positive cable and remove the battery.

#### BATTERY INSTALLATION

Install the battery in the reverse order of removal. After installing the battery, coat the terminals with clean grease.



#### BATTERY CHARGING

Connect charge position (+) cable to the battery positive terminal.

Connect the charge negative (-) cable to the battery negative (-) terminal.

**CHARGING CURRENT : STANDARD : 0.4A**

**SWIFTNESS : 4A**

**CHARGING TIME : STANDARD : 5 hrs**

**SWIFTNESS : 30 min**

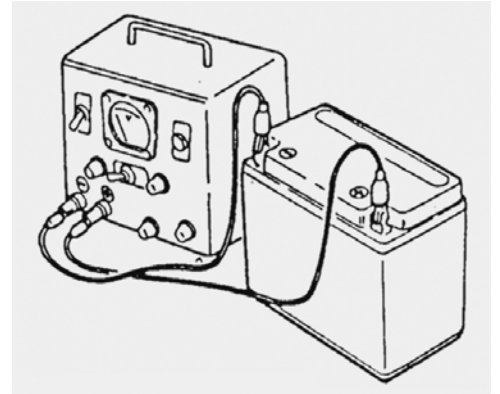

### 七、 ELECTRICAL SYSTEM

#### 7-3 A.C.G. INSPECTION

##### EXCITER COIL INSPECTION

Disconnect the black / red wire of A.C.G.  
Check the black / red and earth wire for  
continuity.

**STANDARD : 300Ω~1KΩ (20°C)**

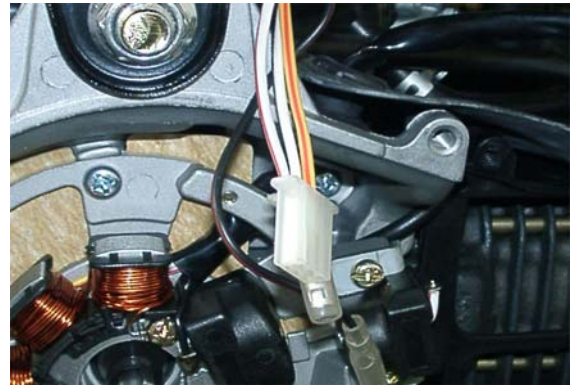

**七、 ELECTRICAL SYSTEM**

**PLUSER COIL INSPECTION**

Disconnect the blue / yellow wire of A.C.G.  
Check the blue / yellow wire and green wire for continuity.  
**STANDARD : 40Ω~300Ω (20°C)**

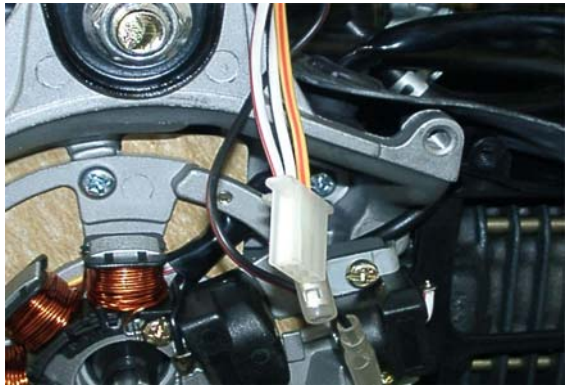

**7-4 RESISTER INSPECTION**

Check the continuity between the wire of resistor and earth.  
**STANDARD:**  
**RESISTER A:**  
**RESISTER B:**

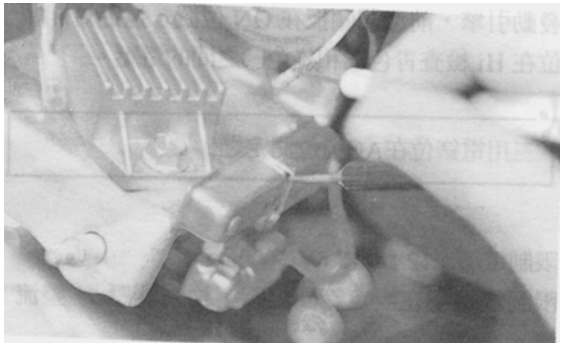

**7-5 C.D.I. INSPECTION**

	GOOD	NG
1. OFF	NO SPARK	—
2. P	↑	—
3. EXT	↑	SPARK
4. ON.1	SPARK	NO SPARK
5. ON.2	↑	↑

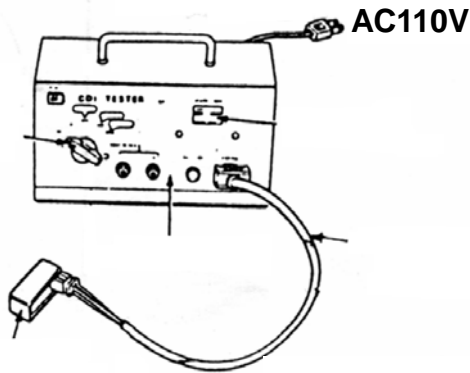

**7-6 IGNITION COIL INSPECTION**

Check the primary coil for continuity.  
Mark connections with an ohmmeter as shown.  
The coil is normal if there is continuity.  
**STANDARD : 0.1Ω~1.0Ω (20°C)**

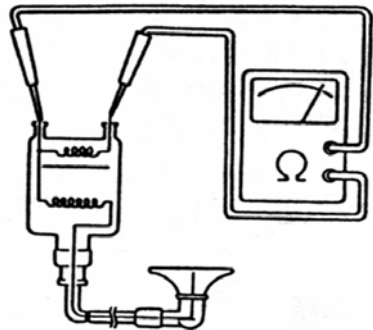

**七、 ELECTRICAL SYSTEM**

Check the secondary coil for continuity.  
The ignite coil is correct if there is continuity.

**STANDARD :**

- With plug cap : 7Ω~12Ω**
- No plug cap : 3~5Ω**

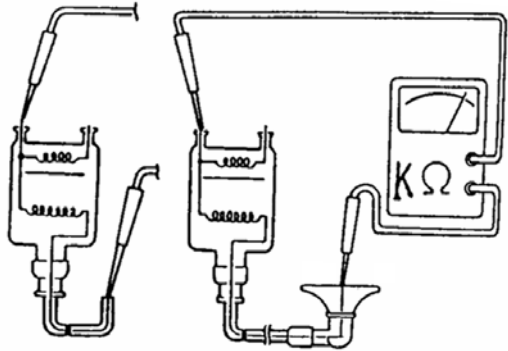

Check the coil output on a ignition coil tester.  
Set the tester to ignition test, dial out the electrodes and observe the spark gap.

- GOOD : Continuous spark.**
- NG : Discontinuous spark**

**NOTE:**

**Follow the instructions supplied with the tester.**

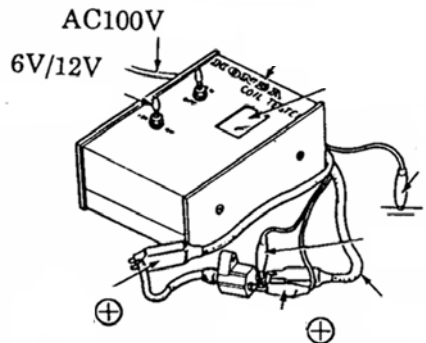

**7-7 START MOTOR**

**START MOTOR INSPECTION**

Connect a battery (12V) to the motor.  
Check the performance of the motor.

**NOTE:**

**Use a fully charged battery.**

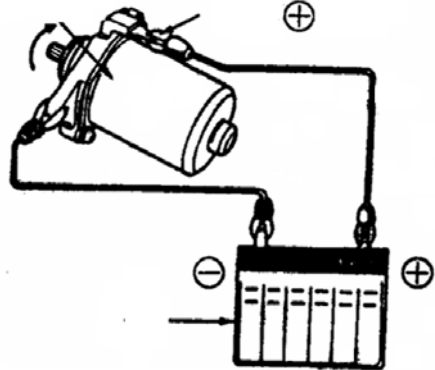

**7-8 START RELLEY INSPECTION**

Connect a battery (12V) between (D) and (C) as show.

Check the continuity between the (A) pole (B) pole.

- GOOD : continuity**
- NG : discontinuity**





**七、 ELECTRICAL SYSTEM**

**7-9 OIL LEVEL GAUGE INSPECTION**

Check the continuity between the brown wire and gray wire as bellow.

OIL FLOAT POSITION		GOOD	NG		
A	UP	×	○	×	○
B	DOWN	○	×	×	○

