

BT49QT-11
User's Manual

Preface

Thank you very much for purchasing 'BAOTIAN' brand motorcycle of model BT50QT-11E, which developed by **BAOTIAN MOTORCYCLE INDUSTRIAL CO., LTD.** And welcome to join the driver's line of BAOTIAN motorcycle.

With its extraordinary advantages of excellent quality, smart appearance and shape of legerity, our product will surely bring the utmost pleasure and convenience to your life.

This manual gives you information about the general structure, function, operation and maintenance methods of BT50QT-11E. In order to enable your beloved motorcycle to render a best performance and a longer life, please read this manual carefully, pay particular attention to the running-in part in it and follow all the operating instruction. It is of great importance to make your riding safer and more comfortable. Experienced staffs in our sale agency and the maintenance shop will also offer excellent service for you.

- Please take an initial examination of your motorcycle after the first 300km running in our designated maintenance shop, and take regular examination in every 1000km thereafter.
- All the direction, illustration and specification included in this manual are based on the latest product information. Please be noted that they may be different from the actual status of the motorcycle if there is new revision on its specification, and no further advice will be given.
- This motorcycle was designed and manufactured which complied with e-mark, the safety standard of Europe Union. The maximum speed is ~~45~~³⁰ km/h. Please do NOT change any parts without professional advice and use non-original parts in case of avoiding danger to driver and the broken of traffic laws.

CONTENTS

Guidance	1
Position of parts	3
Controlling parts	4
Fuel tank	6
Fuel and engine oil	6
Starting pedal	6
Pre-riding inspection	7
Engine starting	8
Running-in	9
Regular maintenance	10
Tools	16
Technical Parameters	17
Electrical Circuit Chart	19

□ Guidance

Please keep safety in your mind and observe the regulations of transportation while enjoying your riding. Pay attention to the following rules:

1. **Pre-riding inspection**

Please read the details in the relevant chapter for your safety.

2. **Helmet**

Do remember to wear helmet while riding.

3. **Being familiar with motorcycle operation**

It is of great importance to ensure your safety getting familiar with motorcycle operation.

4. **Speed limitation**

Drive at proper speed in accordance with the road condition, the weather and your driving skill.

WARNING

It is dangerous to drive on the wet road.
Do not make an abrupt turning while accelerating and keep proper distance from other vehicles.

5. Positions of the numbers

The frame number and the engine number are for the purpose of registering the motorcycle. When your motorcycle needs inspection, repair or other special service, the number will enable you to get good service from our sale agency. Please note down your number here:

The frame number: _____

The engine number: _____

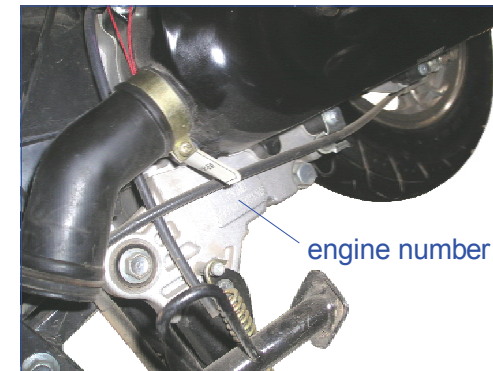
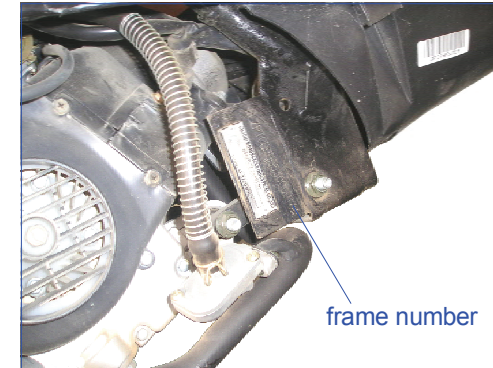

□ Position of parts

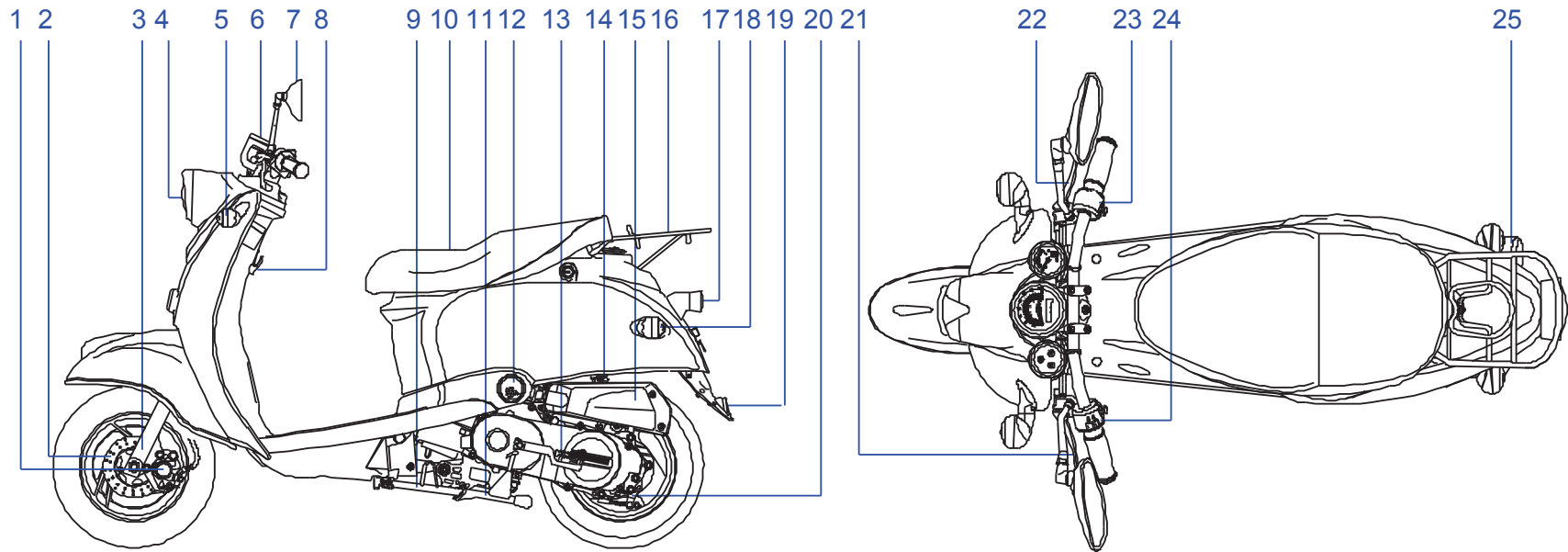

- | | | | | |
|----------------------|-----------------------|--------------------------|-------------------------|------------------------|
| 1. disk brake assy. | 2. brake disc | 3. front shock absorber | 4. head light | 5. front turning light |
| 6. meters | 7. rear-view mirrors | 8. helmet hook | 9. side stand | 10. seat |
| 11. main stand | 12. side reflector | 13. starting pedal | 14. rear shock absorber | 15. air cleaner |
| 16. rear carrier | 17. taillight | 18. rear turning light | 19. rear reflector | 20. drum brake |
| 21. rear brake lever | 22. front brake lever | 23. right switches assy. | 24. left switches assy. | 25. muffler |

1. Rear brake lever

Hold it tightly and the rear brake works.

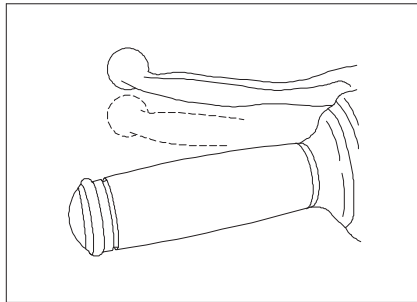

2. Switches on the left

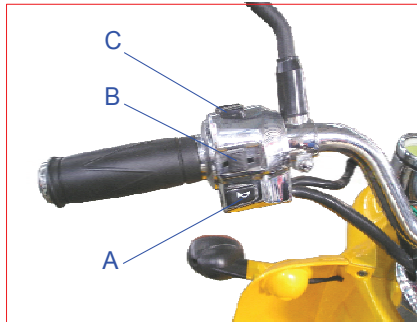

A. Horn button

□ Controlling parts

B. Turning signal switch

← Left turning light

→ Right turning light

C. Switch for high/low beam lights

3. Meters and indicating lights

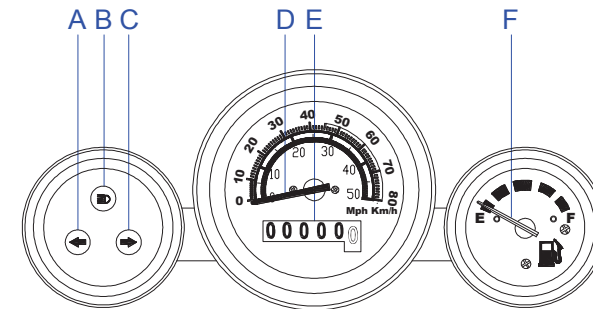

A. Left turning signal light indicator

B. High beam indicator

C. Right turning signal light indicator

D. Indicates the speed in km/h and Mph

E. Indicates total distance the motorcycle has run

F. Fuel gauge

4. Front brake lever

Hold it tightly and the front brake works.

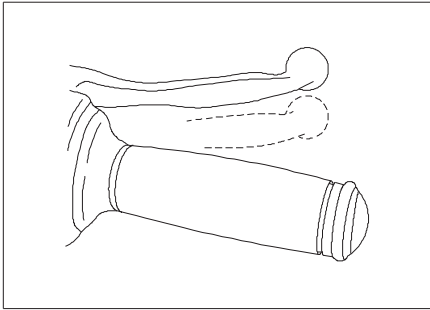

5. Switches on the right

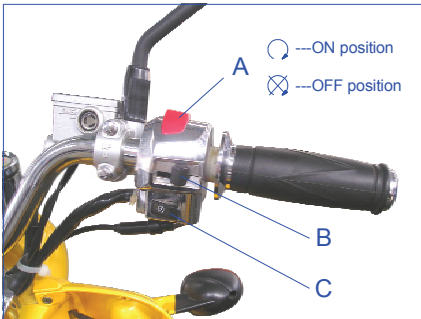

A. OFF switch

ON position: can start the engine

OFF position: cannot start the engine

B. Head light switch

C. Electric starting button

When the ignition switch is at ON position, hold the brake and press the electric starting button and then the engine starts.

6. Ignition switch

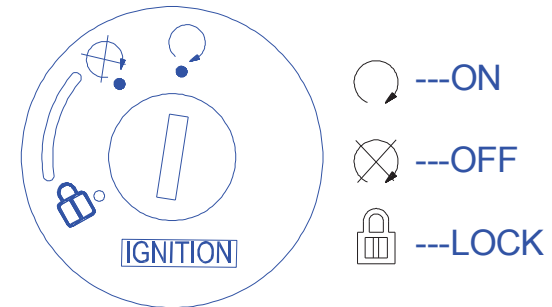

ON: Engine can be started and all the lights can be operated. The key cannot be taken out.

OFF: The whole circuit is cut. Engine and lights cannot be operated and the key can be taken out.

LOCK: Turn the steering handlebar fully to the left, press the key and turn it to the position lock. Then the key can be taken out.

Fuel tank

Usage of the fuel tank lock:

1. Turn the little cap on the fuel cap. Insert the key and turn the key clockwise and take out the fuel cap.
2. Align the lock tongue on fuel cap with the notch on fuel tank, press the fuel cap and lock it.

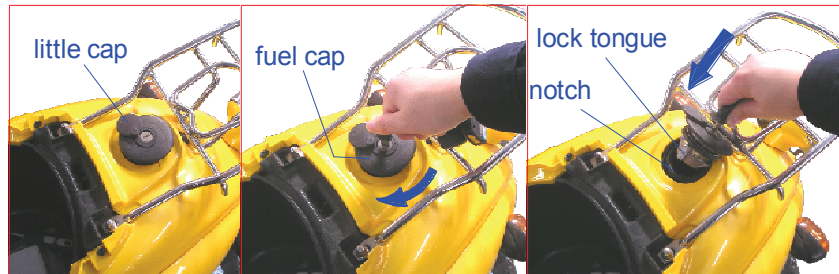

Warning

- ◆ Turn off the engine when refilling the tank.
- ◆ Turn off the cap slowly.
- ◆ Don't overfill the gasoline over the designated scale.
- ◆ Do not add anything into the gasoline.

Fuel and engine oil

A. Gasoline

High quality fuel is essential to the engine.
Any sand in the fuel is absolutely prohibited.
90# or higher quality lead-free gasoline is preferred.

B. Engine oil

SAE15w/40 SF

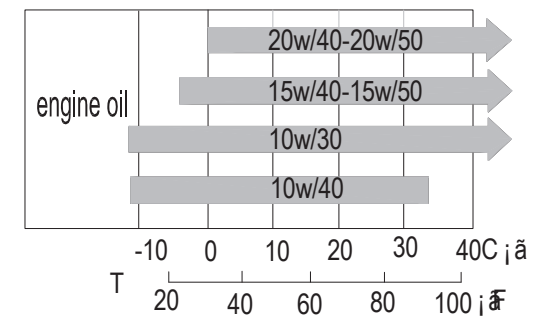

Starting pedal

Starting pedal is for kicking start of the engine.

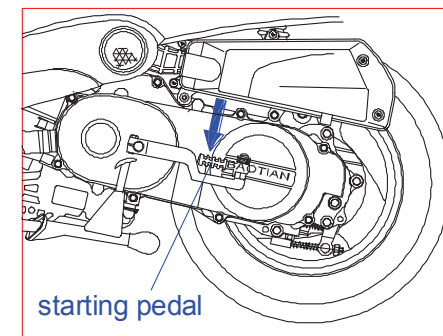

Pre-riding inspection

Please check the following parts before you drive.

No.	Items	Inspection content
1	Steering handlebar	1.Flexibility 2.No gap or loosing appearance
2	Brake system	1.Travel of the front brake and the rear brake 2.No break on the cable 3.Flexible function
3	Tires	1.Proper pressure 2.No crack or cutting
4	Fuel	Sufficient fuel
5	Engine oil	Sufficient engine oil
6	Lights	Workable
7	Horn	Workable
8	Gear oil	With normal stock
9	Throttle	1. Proper gap 2.Flexible function 3.Proper control lever returning
10	All the bolts and nuts	No loosing appearance.

□ Engine starting

1. Please check the volume of engine oil and gasoline before starting. The main stand and the side stand should be taken back while starting the engine.
2. Turn the ignition switch to the "ON" position.

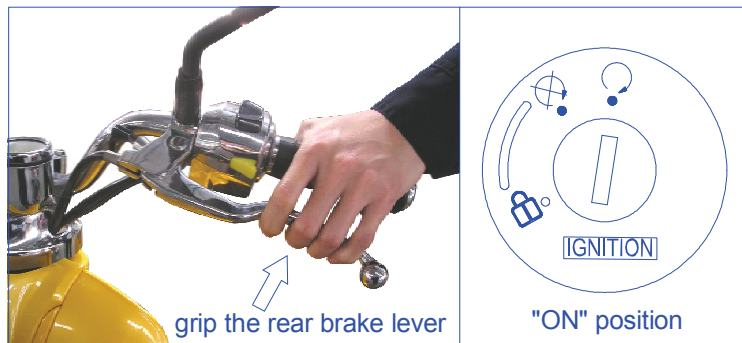

3. Engine Starting

Grip the brake lever and press the starting button and then the engine will be started.

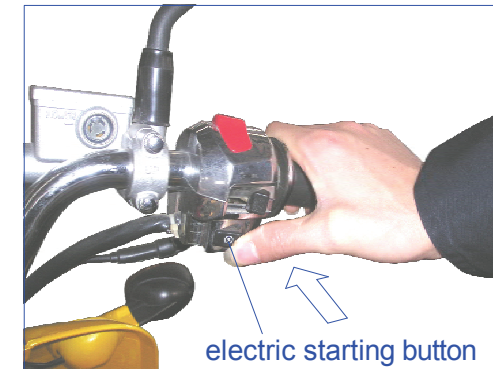

Warning

- ◆ Grip the rear brake lever in case that the motorcycle rushes forwards abruptly.

Warning

- ◆ 5 seconds is the maximum limit for each starting and 10 seconds is the minimum interval.
- ◆ Stop pressing the starting button immediately after the engine starts.
- ◆ Do not press the starting button while the engine is running, or the start motor will be damaged.
- ◆ When using electric starting, please press the rear brake lever in advance to get through the circuit and start the motor.
- ◆ When using electric starting, don't operate the starting motor continually, or it may cause damage to the starting motor and the battery.
- ◆ Warm up the engine after cold starting (about 3 minutes).

4. Kick Starting

Grip the brake lever, tread the starting pedal heavily and then the engine will be started.

Warning

- ◆ After the engine started, the starting pedal should be taken back to its original position. Otherwise, it will affect the driver's safety.
- ◆ Please don't start the engine in unventilated places, because the wasted gas with CO is harmful to human being.

Running in

To keep your motorcycle running in a good condition, please follow the below rules during the running-in period.

Distance (km)	Speed limitation (km/h)
0-300	25
300-1000	35
1000-----	45

□ Regular maintenance

Item	Interval	Km	300	1000	3000	6000	12000
	Month	New motor	1	3	6	12	
Battery		I	I	I	I	I	I
Engine oil strainer				C	C		
Gasoline strainer							R
Carburetor		I		I	I		C
Air cleaner core		Clean it every 2000km and replace it when necessary					
Spark plug		Clean it every 3000km and replace when necessary					
Fuel throttle			A	A	A	A	A
Drive belt					I	I	
Engine oil		R	R	Replace every 3000km			
Brake system		I	I	I	I	I	I
Front fork and steering stem bearing		I	I		I	I	I
Suspension		I		I	I	I	I
Tires		I	I	I	I	I	I
Fastening nuts and bolts		I	F		F	F	F
Gear oil		R	Replace every 5000km / 5Month				
Rear brake cam					C		

NOTE: I=Inspect and clean, adjust, replace or lubricate when necessary, C=Clean, R=Replace, F=Fastened
Service more frequently when riding in dusty conditions.

1. Battery

12V/5.7Ah battery

- ① When the voltage is less than 11.5V, please use kick starting in stead of electric starting.
- ② Put the ignition switch on OFF position before battery replacement.
- ③ Electrode identification: "+"— red line, "-"—green line.
- ④ Change a new battery every 4 years.

2. Carburetor and idling speed adjustment

- ① Keep the engine warmed up for 2-3 minutes.
- ② Adjust the idling speed screw to set the engine at speed of 1900 ± 100 rpm. The idling speed adjusting screw is following:



Warning

- ◆ It has been fully adjusted to the highest position when manufactured.

3. Air cleaner

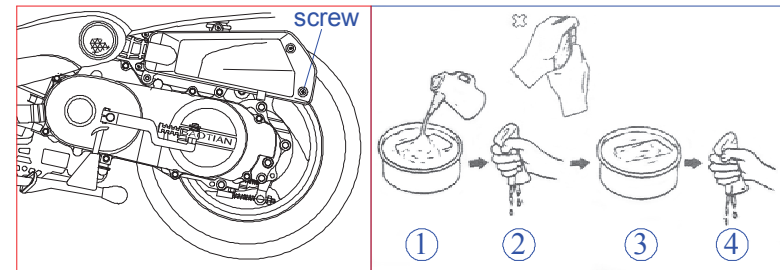

A: Remove 6 tightening screws of air cleaner cover.

Remove air cleaner cover.

B: Take out the sponge core.

CLEANING:

- ① Pour the non-inflammable detergent into a basin and immerse the sponge core into the detergent.

- ② Press the core to squeeze the detergent out of it by palms. Never twist it in case that it is broken.
- ③ Immerse the core into engine oil.
- ④ Squeeze the excessive oil out but keep it lightly oil immersed.

If it has been damaged, please replace a new one.

NOTE: Do not clean it with any oil or water.

4. Spark plug

- ◆ Clean the carbon deposit on the spark plug with a piece of hard wire or steel needle.
- ◆ Adjust the gap to 0.6-0.7mm with a thickness gauge.
- ◆ Use A7RC when replacement is needed.

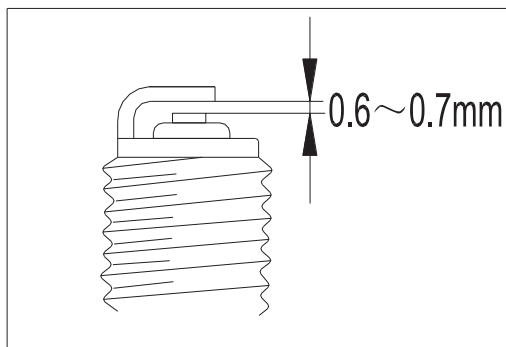

5. Fuel

Refill the recommended 90# or higher quality lead-free gasoline when the indicating needle in the fuel gauge points to the red area.

NOTE: Lead-free gasoline will extend the life of spark plug and catalytic converter.

6. Engine oil

Replace the engine oil under the condition of the engine is warm.

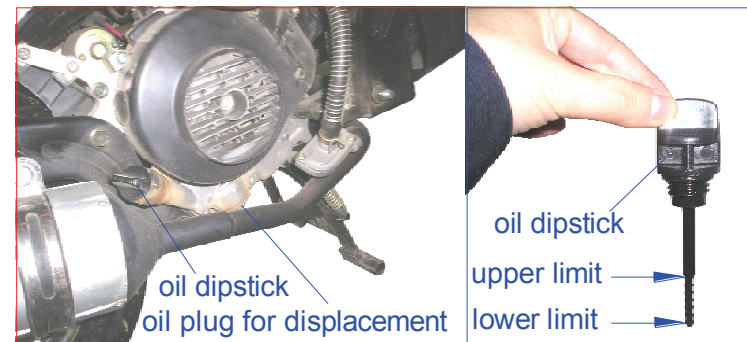

- ① Remove the oil dipstick.
- ② Remove the oil plug for displacement to drain the used oil.
- ③ Reinstall the oil plug for displacement, paying attention to be tightened .
- ④ Refill 0.8 L recommended fresh engine oil.
- ⑤ Fasten all the nuts and screws.

7. Brake system

Normal free travel of the brake lever is about 10-20mm.

- ① The front brake (disk brake)

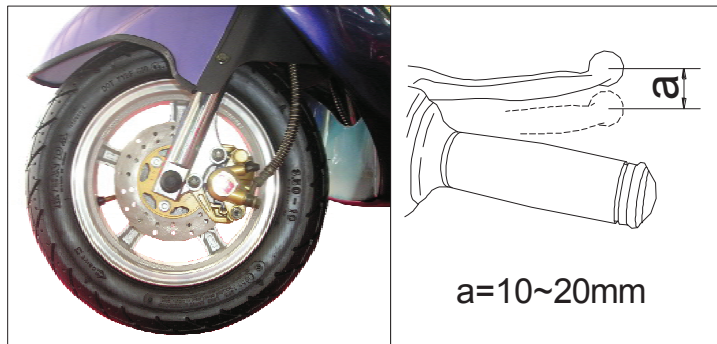

- ② The rear brake (drum brake)

Turn the adjusting nut to get a proper travel.

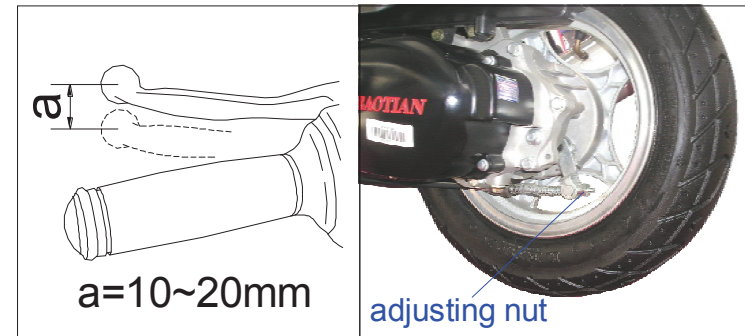

Warning

- ◆ FREE TRAVEL means the distance between the positions from free status to the beginning performance of the brake.
- ◆ Pay attention to the sensitivity of the brake.

☆ **Disk brake**

◆ Grip the brake lever and check the wear and tear indicator. If the indicator nearly touched the brake disc, please ask the appointed maintainer to change the brake blocks.

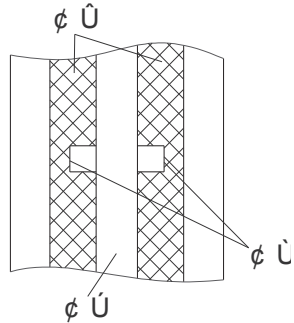

① wear and tear indicator ② brake disc ③ brake blocks

◆ Check the following items of brake system before driving the motorcycle:

- ① Check if there is any leakage.
- ② Check if there is any leakage or crack on the oil pressed hose.
- ③ The brake lever should be kept with a certain free distance of 10~20mm and kept a certain re-grip power.
- ④ Abrasion of the brake blocks.

◆ Brake oil level

- ① It has been filled with the special brake oil before the motorcycle leaves the factory. User should fill or replace the qualified brake oil (such as No.DOT3 or DOT4 brake oil) from the appointed maintenance station. Never replace or mix other oil, otherwise it would damage the brake system.
- ② If the brake oil is insufficient, it might be possible for the air to come into the brake system and result in the failure of the system.

Warning

- ◆ Brake oil is corrosive material. It would damage and corrupt the painting of the part. It should be cleanout if the oil splash on the part.
- ◆ If the oil sprayed on the skin or eyes, it should be cleaning quickly with a lot of water.

8. Tires

Insufficient tire pressure hastens wear of them and affects the riding stability. Please check the tire pressure and tread depth when applying regular maintenance.

- ① Tire pressure: front 225 kPa; rear 225 kPa.
- ② Tread depth: It is suggested to replace a new tire when the tread depth is less than 1 mm.

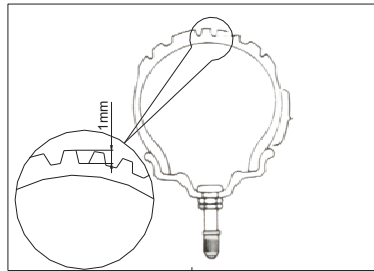

Warning

- ◆ The standard tire is 3.50-10 51J for front and rear tires. Another type of tire may cause trouble.
- ◆ Tire inflation pressures and the general tire condition are extremely important to the proper performance and safety of the vehicle.

9. Starting motor

Check the fastening bolts and the carbon brush, and replace them if necessary.

10. Fuse

Fuse is linked with the outer line of the battery. When a light or circuit fails suddenly, please check the fuse first.

Warning

- ◆ The fuse can not be replaced by any iron or aluminum wire.

11. Gear oil

Please use the recommended gear oil: SAE85W/90

Total capacity: 110ml

Replacing capacity: 100ml

How to change gear oil

- Stand up the main stand.
- Take off the oil plug for refill.
- Take off the oil plug for draining, let off all the dirty gear oil.
- Tighten the oil plug for draining.
- Refill fresh gear oil and tighten the oil plug for refill.

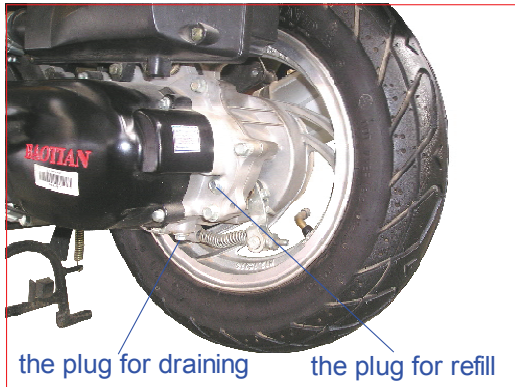

After refilling, please make sure you have locked the oil plugs and bolts.

Tools

A full set of tools is offered for your daily use.

□ Technical Parameters

Items		Specifications
Size	Length	1680mm
	Width	680mm
	Height	1070mm
	Wheel base	1210mm
Weight	Unloaded weight	77kg ± 3kg
	Mass weight	157kg ± 3kg
Capacity	Max. Speed	30 45km/h
Circuit system	Spark plug	A7RC
	Battery	12V/5.7AH
	Fuse	10A
	Headlight	12V 35/35W
	Front turning lights	12V 10W
	Rear turning lights	12V 10W
	Brake light	12V 21/5W
	Position lights	12V 5W
Volume of the fuel tank		7L ± 0.2L
Volume of the engine oil tank		1L

Items		Specifications
Engine	Model Type Cylinder Bore and stroke Cylinder volume Compression ratio Idling speed Max. Power Max. Torque Carburetor Air cleaner Ignition type Starting mode Cooling mode Lubrication	139QMB 4 stroke 1 39.0mm × 41.4mm 50cm ³ , 10.5 ± 0.1:1 1900 ± 100 r/min 2.2kW/7500r/min 2.9N • m/7000r/min 139QF Sponge core CDI Electric/kicking start Forced air-cooled Pressure spray
Brake system		Front: disk brake Rear: drum brake
Suspension	Front shock absorber Rear shock absorber	Variable-pitch spring & hydraulic damping shock absorber Variable-pitch spring & hydraulic damping shock absorber
Tires		3.50-10 51J for front and rear tires

Electrical Circuit Chart

